

Peak200

Digital Control for Steam Turbines

Applications

The Peak200 controller is designed to operate small single valve, or single valve-rack industrial steam turbines. This cost-effective steam turbine controller includes specifically designed algorithms and logic to start, stop, control, and protect small industrial steam turbines or turbo-expanders driving compressors, pumps, or industrial fans.

The Peak200 control's unique PID structure makes it ideal for applications where it is required to control steam plant parameters like turbine speed, turbine load, turbine inlet header pressure, turbine exhaust header pressure, pump flow, or compressor discharge, or suction pressure.

The control's special PID-to-PID logic allows stable control during normal turbine operation and bumpless control mode transfers during plant upsets, minimizing process over or undershoot conditions. The Peak200 controller senses turbine speed via passive speed probes and controls the steam turbine through an actuator connected to the turbine inlet steam valve(s). Peak 200 includes Woodward's patented adaptive PID controller that allows users automatic calculation for optimum dynamic gains at their individual plant system.

Designed to function as a plant DCS node the Peak200 controller can be configured to interface with the plant DCS via hardwired inputs/output signals or serial or Ethernet communications. With the capability to monitor and control all turbine and driven equipment based functions (i.e. bearing temperatures, vibration levels, control oil levels, etc.) the Peak200 controller is ideal for use as a cost-effective turbine control/protection as well as plant DCS monitoring node.

Alternatively the Peak200 can be configured to accept a remote turbine speed/load demand from the plant DCS via a 4-20mA signal, discrete raise/lower commands, or Ethernet or Serial Modbus communications.

The Peak200 control also includes a special "Cascade" PID control function that can be optionally configured and used to control any system process, related to or affected by turbine speed or load. Typically, this controller is configured and used to control turbine inlet header pressure, turbine exhaust header pressure, pump flow, or compressor discharge, or suction pressure. The Cascade PID compares a 4–20 mA process signal with an internal set point to directly position the Speed PID controller's setpoint, thus changing turbine speed or load until the process signal and set point match. By cascading these two PIDs in this fashion, bumpless transfers can be performed as well as turbine min/max.

Ethernet and serial communications allow users to easily connect the Peak200 in to plant or process control system. All controller inputs, outputs, and statuses can be monitored and all start/stop or enable/disable commands can be given through industry standard Modbus TCP. The Peak200 uses SNTP (synchronized network time protocol) over Ethernet to allow users to synchronize the Peak200's real-time clock to the plant distributed control system.



- Field configurable
- Integrated graphical operator control panel
- Simple to install, configure & operate
- Integrated first-out problem indicator
- Trip and Alarm event recorder
- Internal Turbine Simulator
- Adaptive PID controller
- Real-time clock synchronization via SNTP
- Ethernet & Serial communications
- Same form-fit-function as previous Peak150 controller
- Bulkhead & Front Panel Mount versions available
- Sulfur-resistant conformal coating
- Certified for Hazardous Locations

Description

The Peak200 control is available in either bulkhead models designed to be mounted on a wall or skid near the turbine or panel-mount models designed to be installed within a standard panel or cabinet door. The product is designed to meet NEMA 4x corrosion resistance tests and has an ingress protection rating of IP56, protecting it against dust and water jets.

The control's front panel serves as both a programming station and operator control panel (OCP). This user-friendly front panel allows engineers to access and program the unit to the specific plant's requirements, and plant operators to easily start/stop the turbine and enable/disable any control mode.

Password security is used to protect all unit program mode settings. The controller's 5" graphical display allows operators to view actual and setpoint values from the same screen, simplifying turbine operation.

Turbine interface input and output wiring access is located on the controller's lower back panel. Un-pluggable terminal blocks allow for easy system installation, troubleshooting, and replacement. Optionally users can increase the number of inputs and outputs signals to/from the Peak200 control by connecting LinkNet-HT distributed I/O nodes to the controller's CAN communication ports and configuring the Peak200 control to use the connected distributed inputs and outputs. The following additional I/O signals can be connected to the Peak200 control via CAN communications:

- (8) 4-20mA input channels and 2 4-20mA output channels (via 1 LinkNet-HT AIO module)
- (8) RTD signals (via 1 LinkNet-HT RTD module)
- (16) Discrete Inputs (via 1 LinkNet-HT DI module)
- (16) Relay output drivers (via 1 LinkNet-HT DO module)

Designed for steam turbine control, the Peak200 control includes two PID controllers (Speed & Cascade) multiple startup routines (manual, automatic, remote control), and multiple protection functions (overspeed, critical speed range, etc.) which can be configured by a user depending on the specific turbine application's requirements. Users can configure the Peak200's different PID controllers, start routines, and protection levels themselves without the need for a special control engineer. Once configured, the Peak200 performs a configuration check routine to ensure that the programmer did not make any basic configuration mistakes.

Optionally users can utilize Woodward's RemoteView software program with the Peak200 to function as a remote operator control panel and or engineering station. This software program once loaded onto a remote computer or touch panel, allows the user the following additional functionality:

- Perform the identical Peak200 front panel display functions (monitor, operate, tune, and configure) on the respective computer or touch panel.
 - Full function free for 2 hours
 - Licensable for continuous GUI operation
 - Password based login level security is utilized allowing function management for RemoteView applications
- Refer to Woodward product specification B03424 for additional information.

The Peak200 includes a suite of service tools to allow users to perform the following functions:

- Upload configuration settings files from the Peak200 to save on another device
- Download configuration settings files to the Peak200
- View real-time or saved trend files

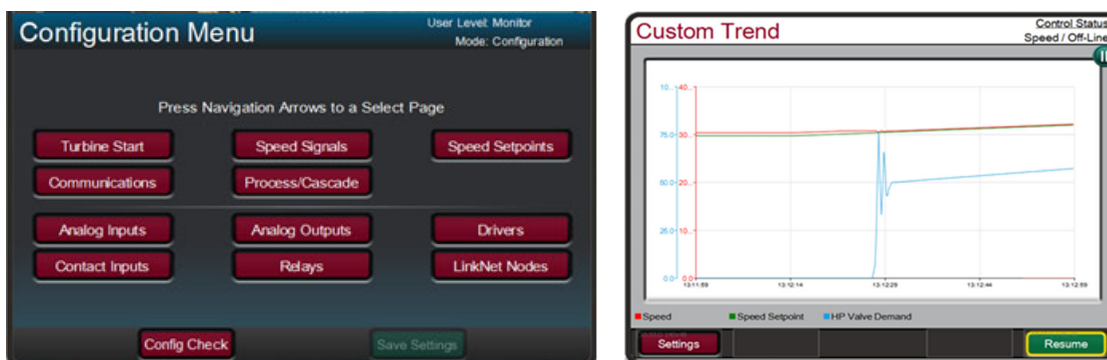

Figure 1. Example RemoteView Screens

Features

Control

- Dual dynamics (Speed PID)
- Adaptive speed/load PID dynamics
- Cascade PID (turbine/driven equipment pressures or flows)
- Manual or auto start sequence
- First-Out indication (alarms & shutdowns)
- Peak speed Indication for overspeed trip
- Multi-lingual Display (English & Additional Languages TBD)
- Remote analog setpoints for Speed/Load & Cascade
- Bearing temperature monitoring/alarms/trips
- Vibration monitoring/alarms/trips

System Protection

- Overspeed protection logic & test capability
- Critical speed band protection (1 band)
- First-out Indication (5 individual shutdown inputs)
- Bearing temperature alarm and trip settings
- Turbine vibration alarm and trip settings
- Control CPU & memory failure detection logic
- Mode login level password security

Cost-Effective Design— The Peak200 control is designed to function as the turbine control, system sequencer, operator control panel, and first-out indicator. This encompassing design minimizes external system devices as well as system installation, wiring, and troubleshooting. This field configurable controller allows major functional changes to be made at site, often by knowledgeable plant personnel, and minor functional changes to be online as process changes require. The Peak200 control's first-out-indicator logic indicates internal as well as external system related alarm and shutdown conditions, greatly simplifying and reducing system troubleshooting.

Communications— The Peak200 controls can communicate directly with plant Distributed Control Systems and/or operator control panels, through two Ethernet ports using Modbus TCP or UDP communication protocols or via a serial Modbus port. The Peak200's serial port supports RS-232 or RS-485 communications using ASCII or RTU Modbus protocols. Communications between the Peak200 and a plant DCS can also be performed through hardwired connections.

Control Specifications

INPUTS

	LV models = 18 - 36Vdc
Power:	HV models = 88 - 264Vac & 90-150Vdc (45 watts max)

Speed:	(2) Passive MPUs (100 – 35,000 Hz)
--------	------------------------------------

Discrete Inputs:	(8) Configurable Contact Inputs (optionally (16) additional inputs via LinkNet-HT module)
------------------	--

Analog Inputs:	(4) Configurable 4-20mA Inputs (optionally (16) additional inputs via LinkNet-HT module)
----------------	---

OUTPUTS

Valve/Actuator Drivers:	(1) Actuator Output, 4-20mA and 20-200mA
-------------------------	--

Discrete Outputs:	(4) Relay Outputs (24Vdc @ 2 amps, Form-C contacts) (optionally 16 additional outputs via LinkNet-HT module)
-------------------	--

Analog Outputs:	(3) 4-20 mA Outputs (optionally 2 additional outputs via LinkNet-HT modules)
-----------------	--

COMMUNICATIONS

Ethernet:	(2) ports (Modbus TCP or UDP protocols)
-----------	---

Serial:	1 Modbus port (ASCII or RTU) Comm Ports (RS-232 or RS-485 compatible)
---------	---

CAN:	(2) ports (LinkNet-HT comm. protocol)
------	---------------------------------------

Functionality

The Peak200's control capabilities are:

- Turbine Speed/Load control
- Inlet Header Pressure control
- Turbine inlet/exhaust header pressure control
- Pump flow/pressure control
- Compressor flow/pressure control

Control Accessories

LinkNet-HT Modules – Optionally users can apply Woodward distributed I/O modules to extend the Peak200 controller's input and output channels.

Vibration Sensor Kit – Optionally users can apply 4-20mA accelerometer sensors with the Peak200 to monitor unit vibration levels and alarm & trip on high vibration events. Refer to product manual for related kit part numbers.

RemoteView - Woodward's RemoteView software program once installed on a computer or touch panel can be used as an engineering workstation and or remote operator control panel.

Stored Trend/Log File Service Tool – Woodward's Control Assistant software service tool can be used to view real-time trends, saved trend files, upload and download Peak200 configuration files and alarm/trip logs

Operating Conditions

- -20 to +65°C (-20 to 70°C for Panel Mount Version) ambient air temperature range
- Humidity: 5% to 95% non-condensing Lloyd's ENV2 test #1
- Dry heat: Lloyd's ENV3
- Salt fog: US MIL-STD-810 method 509.2 procedure 1, Type 4X Enclosure UL50E 8.9 corrosion protection test ASTM B117
- Shock: 10G, 3x axis per Woodward MS2 procedure
- Vibration: 1.04Grms, industrial skid mount per Woodward RV5

Pollution Resistance

- Particulate Pollution Resistance: IEC 60664-1 Pollution Degree 2 (Normally only nonconductive pollution occurs).
- Gaseous Pollution Resistance: Module conformal coating withstands NO₂, CO₂, SO₂, and H₂S gases
- Will withstand levels typical of telecommunications and computer installations as defined by Battelle Labs Class III (between IEC60721-3-3 classification 3C1 and 3C2, light industrial to urban industrial, heavy traffic).

Regulatory Compliance

European Compliance for CE Marking

These listings are limited to only those units bearing the CE Marking.

EMC Directive: 2014/30/EU

LVD Directive: 2014/35/EU

ATEX Directive: 2014/34/EU,  II 3 G Ex ic nA nC IIC T4 Gc

RoHS Directive: 2011/65/EU, Woodward Turbomachinery Systems products are intended exclusively for sale and use only as a part of Large Scale Fixed Installations per the meaning of Art.2.4(e) of directive 2011/65/EU. This fulfills the requirements stated in Art.2.4(c) and as such the product is excluded from the scope of RoHS2.

Other International Compliance

IECEx: CSA 17.0004X, Ex ic nA nC IIC T4 Gc
(Zone2, Category 3, Group II G)

INMETRO Brazil: NCC certificate BRA-17-GE-0007, Ex ic nA nC IIC T4 Gc
(Zone2, Category 3, Group II G)

United Kingdom Compliance for UKCA Marking:

UKEX: S.I. 2016 No.1107: Equipment and Protective Systems Intended for use in Potentially Explosive Atmospheres Regulations 2016

 II 3 G Ex ic nA nC IIC T4 Gc

EMC: S.I. 2016 No. 1091: Electromagnetic Compatibility Regulations 2016

LVD: S.I. 2016 No. 1101: Electrical Equipment (Safety) Regulations 2016

RoHS Directive: S.I. 2020 No. 1647: The Hazardous Substances and Packaging (Legislative Functions and Amendments) (EU Exit) Regulations 2020

North American Compliance

Listings are limited only to those units bearing the appropriate CSA Marking

CSA: CSA Certified for Class I, Div. 2, Groups A, B, C and D, T4 at the rated ambient temperature for use in Canada and the United States, CSA certificate 70101251
CSA Certified for Ordinary Locations, CSA Certificate 70101251

General Compliance:

Please refer to Product Manual B35051 for installation constraints, safety conditions, grounding, and shielding requirements.

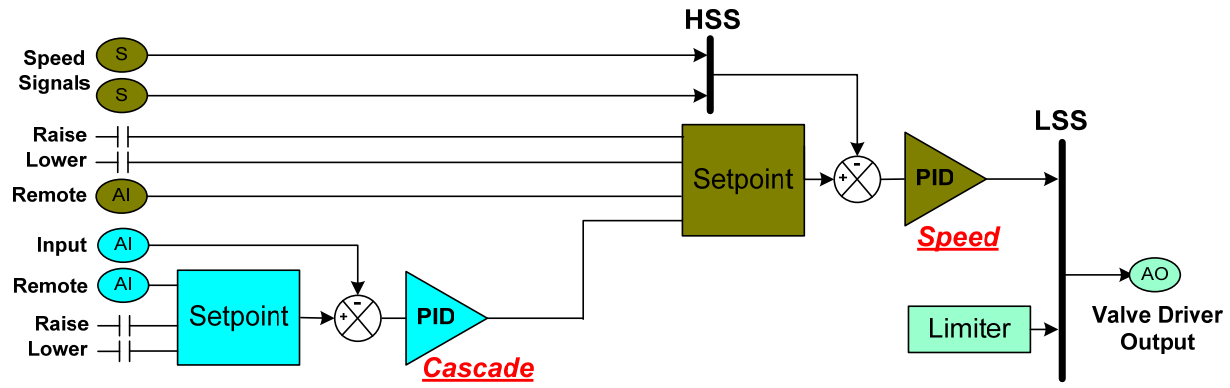

Figure 2. Basic Non-Ext/Adm Functional Control Diagram

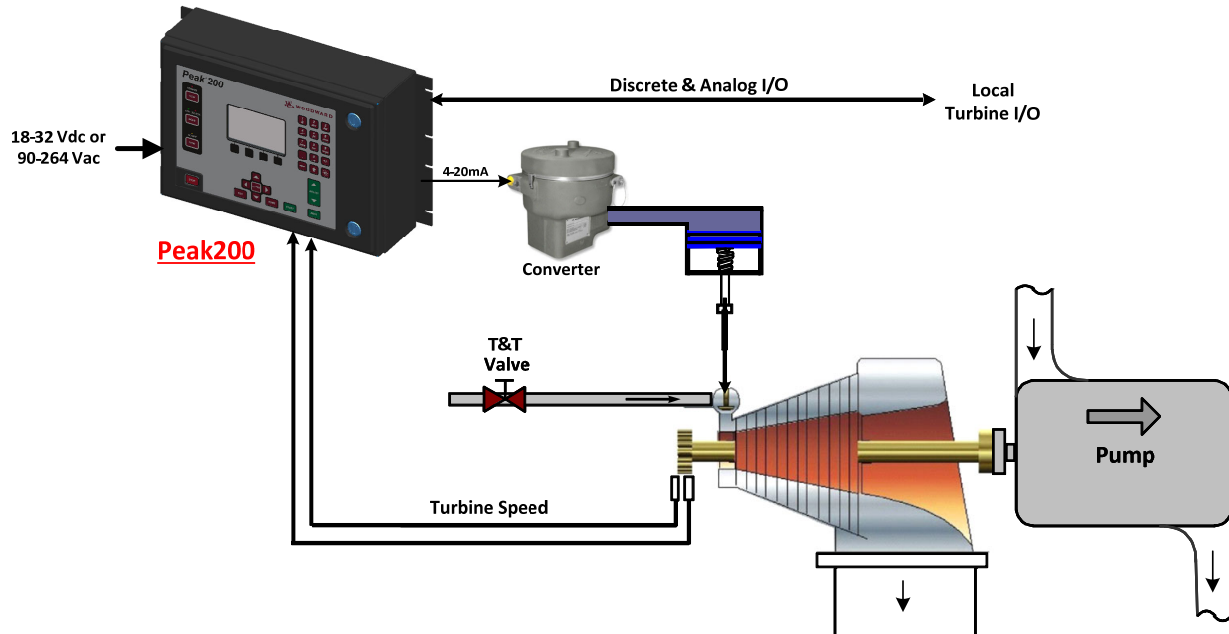

Figure 3. Typical Simple Peak200 Application

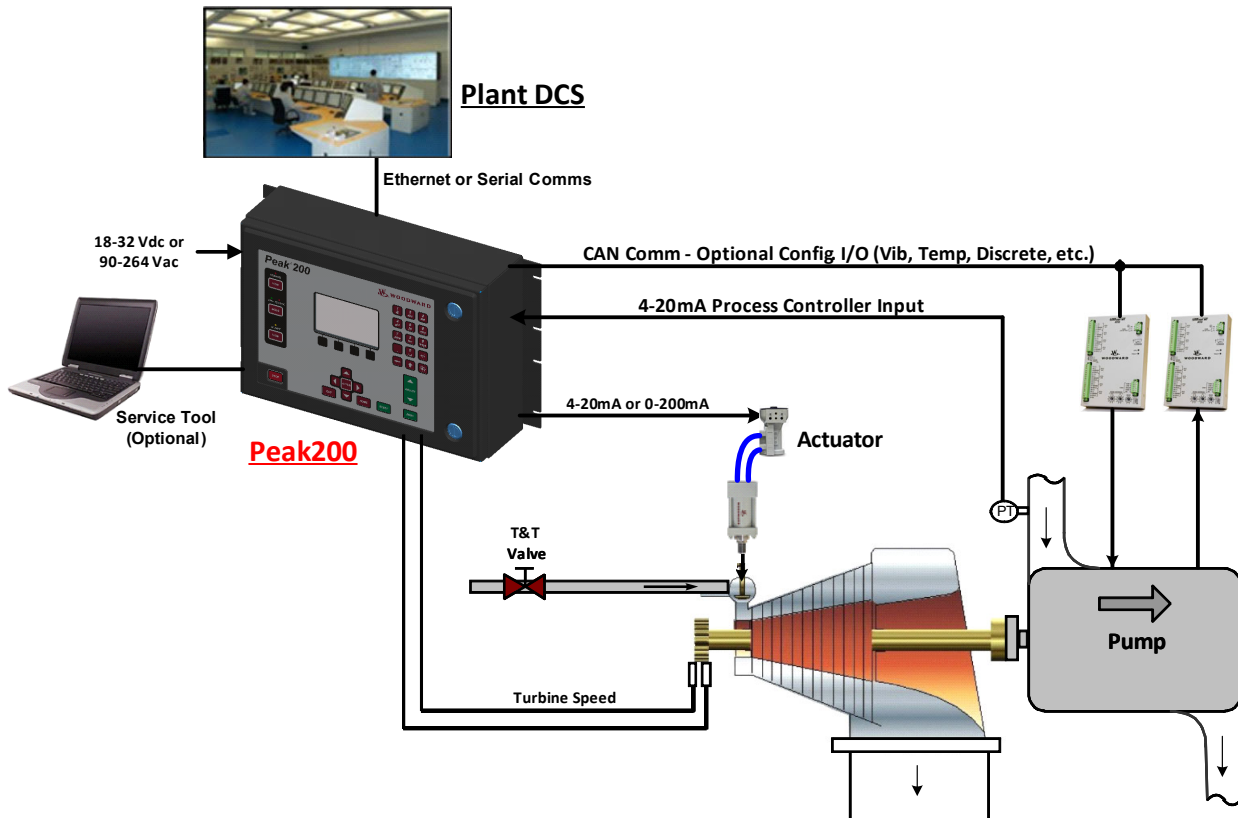

Figure 4. Typical Complex Peak200 Application

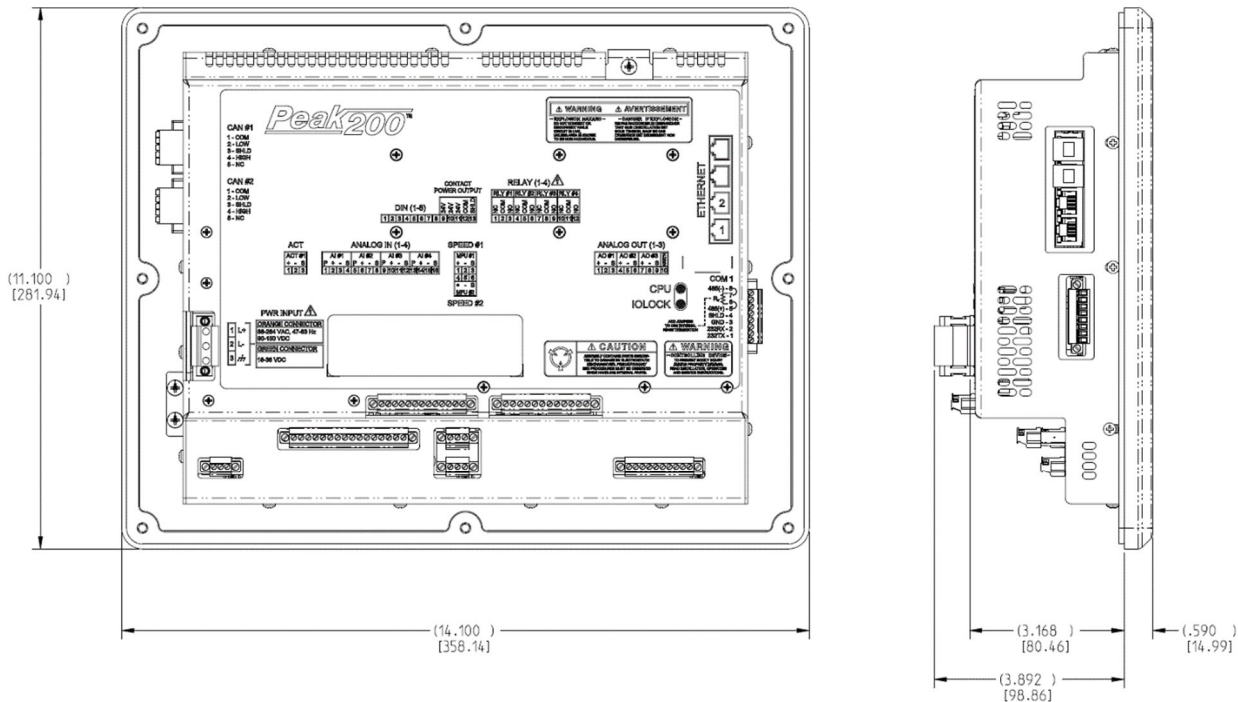

Figure 5. Peak200 Dimensions (Front Panel Mount Models)

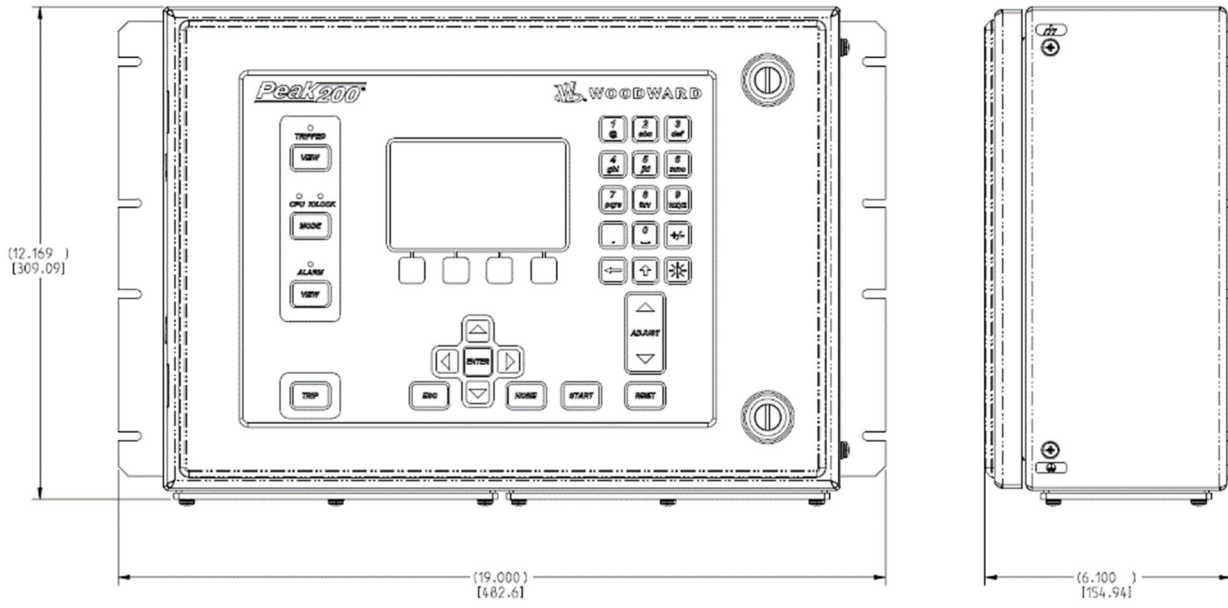

Figure 6. Peak200 Dimensions (Bulkhead Mount Models)



PO Box 1519, Fort Collins CO, USA 80522-1519
1041 Woodward Way, Fort Collins CO 80524
Tel.: +1 (970) 482-5811
www.woodward.com

Distributors & Service

Woodward has an international network of distributors and service facilities. For your nearest representative, call the Fort Collins plant or see the Worldwide Directory on our website.

This document is distributed for informational purposes only. It is not to be construed as creating or becoming part of any Woodward contractual or warranty obligation unless expressly stated in a written sales contract.

Copyright © Woodward 2009–2023, All Rights Reserved

For more information contact:

