



CPC-DX
Current to Pressure Converter
Dual Transfer Skid
(For hydraulic pressure systems)

CPC-DX SKID 10 BAR PN: 8918-116
CPC-DX SKID 25 BAR PN: 8918-118

Installation and Operation Manual



General Precautions

Read this entire manual and all other publications pertaining to the work to be performed before installing, operating, or servicing this equipment.

Practice all plant and safety instructions and precautions.

Failure to follow instructions can cause personal injury and/or property damage.



Revisions

This publication may have been revised or updated since this copy was produced. To verify that you have the latest revision, check manual **26455**, *Customer Publication Cross Reference and Revision Status & Distribution Restrictions*, on the *publications* page of the Woodward website:

www.woodward.com/publications

The latest version of most publications is available on the *publications* page. If your publication is not there, please contact your customer service representative to get the latest copy.



Proper Use

Any unauthorized modifications to or use of this equipment outside its specified mechanical, electrical, or other operating limits may cause personal injury and/or property damage, including damage to the equipment. Any such unauthorized modifications: (i) constitute "misuse" and/or "negligence" within the meaning of the product warranty thereby excluding warranty coverage for any resulting damage, and (ii) invalidate product certifications or listings.



Translated Publications

If the cover of this publication states "Translation of the Original Instructions" please note:

The original source of this publication may have been updated since this translation was made. Be sure to check manual **26455**, *Customer Publication Cross Reference and Revision Status & Distribution Restrictions*, to verify whether this translation is up to date. Out-of-date translations are marked with . Always compare with the original for technical specifications and for proper and safe installation and operation procedures.

Revisions— A bold, black line alongside the text identifies changes in this publication since the last revision.

Woodward reserves the right to update any portion of this publication at any time. Information provided by Woodward is believed to be correct and reliable. However, no responsibility is assumed by Woodward unless otherwise expressly undertaken.

Contents

WARNINGS AND NOTICES	3
ELECTROSTATIC DISCHARGE AWARENESS.....	4
REGULATORY COMPLIANCE.....	5
CHAPTER 1. GENERAL INFORMATION	7
Introduction	7
System Description	7
Design Characteristics	9
Construction	9
CHAPTER 2. SYSTEM SPECIFICATIONS	16
CHAPTER 3. INSTALLATION	19
Receiving Instructions	19
Mounting Instructions	20
Hydraulic Connections	21
Electrical Connections.....	21
Input Power	21
Shielded Wiring	25
Wiring	25
CPC-DX Calibration	25
CHAPTER 4. OPERATION.....	26
CPC-DX performance	32
Online Change-Out of a Pressure Gauge.....	40
CHAPTER 5. REPAIR AND TROUBLESHOOTING.....	42
General.....	42
Troubleshooting	43
CHAPTER 6. PRODUCT SUPPORT AND SERVICE OPTIONS	46
Product Support Options.....	46
Product Service Options	46
Returning Equipment for Repair	47
Replacement Parts.....	48
Engineering Services	48
Contacting Woodward's Support Organization	48
Technical Assistance	49
CHAPTER 7. ASSET MANAGEMENT AND REFURBISHMENT SCHEDULING PERIOD	50
CHAPTER 8. LONG-TERM STORAGE REQUIREMENTS	51
REVISION HISTORY	52
DECLARATIONS	53

Illustrations and Tables

Figure 1-1. Basic CPC-DX Application and Configuration	8
Figure 1-2. CPC-DX Main Components	9
Figure 1-3. CPC-DX Installation Drawing Front view	10
Figure 1-4. CPC-DX Installation Drawing, Top view	11
Figure 1-5. CPC-DX customer interface	12
Figure 1-6. CPC-DX Main Terminal Box, Wiring Diagram	13
Figure 1-7. CPC-DX Main Terminal Block Connections List	14
Figure 1-8. Internal CPC wiring diagram	15
Figure 2-1. Internal Leakage, CPC-DX Skid, 10 bar supply pressure, oil viscosity 20 cSt;	18
Figure 2-2. Internal Leakage, CPC-DX Skid, 25 bar supply pressure, oil viscosity 20 cSt;	18
Figure 3-1. CPC-DX Lifting eyebolt location.	20
Figure 3-2. Power Supply Input Connections	22
Figure 3-3. Wiring Connections for Master Designation	23
Figure 3-4. PE ground connection localization and details	24
Figure 4-1. Isolation Valve OPEN / CLOSED Lever Position	27
Figure 4-2. CPC-DX Unit with All Isolation Valves in CLOSED Position	28
Figure 4-3. CPC-DX Unit CPC-II Unit #1 with Supply and Control Isolation Valves in Open Position	29
Figure 4-4. CPC-DX Unit With All Isolation Valves in OPEN Position	30
Figure 4-5. CPC-DX Skid with CPC-II Unit #1 Control Isolation Valve in CLOSED Position	30
Figure 4-6. CPC-DX Status Link Disconnection Inside Main Terminal Box	31
Figure 4-7. CPC-DX Unit to Unit Control Switchover – Switchover Action Typical Performance	32
Figure 4-8. CPC-DX Unit Control Takeover (Second Unit Shutdown Simulation)	33
Figure 4-9. CPC-DX Skid Pressure between CPC-II Units (Pressure Offset) at 20 cSt Oil Viscosity	34
Figure 4-10. Tuning Runs Showing the Effect of Adjusted Primary Gain Example Parameter Values	35
Figure 4-11. Tuning Runs Showing the Effect of Adjusted Proportional Trim Example Parameter Values	36
Figure 4-13. 38	
Figure 4-14. Low LLC Parameter – Sluggish Response, Visible Controlled Unit Position Variation, and Unit-To-Unit Performance Difference	39
Figure 4-15. Low LLC Parameter – Slightly Sluggish Response, Still Visible Controlled Unit Position Variation, and Unit To Unit Performance Difference	39
Figure 4-16. High LLC Parameter – Visible Controlled Unit Position Overshoot, Acceptable Unit-To-Unit Performance Difference	40
Figure 4-17. Pressure Gauge Untightening from Manifold	40
Figure 4-18. Pressure Gauge Untightening From Adapter	41
Table 1-1. Terms and Definitions	7
Table 1-2. Woodward Reference Literature	7
Table 2-1. Environmental	16
Table 2-2. Physical	16
Table 2-3. Electrical	16
Table 2-4. Hydraulic	16
Table 2-5. CPC-DX Maximum Input/Supply Pressure	17
Table 2-6. Hydraulic parameters	17
Table 3-1. Fuse/Breaker Requirements	22
Table 5-1. List of available Replacement Kits	42
Table 5-2. Troubleshooting	43

Warnings and Notices

Important Definitions



This is the safety alert symbol used to alert you to potential personal injury hazards. Obey all safety messages that follow this symbol to avoid possible injury or death.

- **DANGER** - Indicates a hazardous situation, which if not avoided, will result in death or serious injury.
- **WARNING** - Indicates a hazardous situation, which if not avoided, could result in death or serious injury.
- **CAUTION** - Indicates a hazardous situation, which if not avoided, could result in minor or moderate injury.
- **NOTICE** - Indicates a hazard that could result in property damage only (including damage to the control).
- **IMPORTANT** - Designates an operating tip or maintenance suggestion.

WARNING

**Overspeed /
Overtemperature /
Overpressure**

The engine, turbine, or other type of prime mover should be equipped with an overspeed shutdown device to protect against runaway or damage to the prime mover with possible personal injury, loss of life, or property damage.

The overspeed shutdown device must be totally independent of the prime mover control system. An overtemperature or overpressure shutdown device may also be needed for safety, as appropriate.

WARNING

**Personal Protective
Equipment**

The products described in this publication may present risks that could lead to personal injury, loss of life, or property damage. Always wear the appropriate personal protective equipment (PPE) for the job at hand. Equipment that should be considered includes but is not limited to:

- Eye Protection
- Hearing Protection
- Hard Hat
- Gloves
- Safety Boots
- Respirator

Always read the proper Material Safety Data Sheet (MSDS) for any working fluid(s) and comply with recommended safety equipment.

WARNING

Start-up

Be prepared to make an emergency shutdown when starting the engine, turbine, or other type of prime mover, to protect against runaway or overspeed with possible personal injury, loss of life, or property damage.

WARNING

**Overspeed /
Overpressure**

Never close the drain line when supply pressure is present on the CPC unit, otherwise the control output pressure can increase suddenly and cannot be controlled by the input setpoint. This could cause the turbine to overspeed. The supply pressure isolation valve and the control pressure isolation valve should always be closed prior to closing the drain line.

! WARNING

Never disconnect the redundancy linkage between CPCs when BOTH units are powered.

! WARNING

Only trained personnel are allowed to work on this device during operation.

NOTICE**Battery Charging Device**

To prevent damage to a control system that uses an alternator or battery-charging device, make sure the charging device is turned off before disconnecting the battery from the system.

IMPORTANT

If necessary to comply with site safety procedures secure the control and supply isolation valves with a padlock and tag to lock out the CPC-DX system.

Electrostatic Discharge Awareness

NOTICE**Electrostatic Precautions**

Electronic controls contain static-sensitive parts. Observe the following precautions to prevent damage to these parts:

- Discharge body static before handling the control (with power to the control turned off, contact a grounded surface and maintain contact while handling the control).
- Avoid all plastic, vinyl, and Styrofoam (except antistatic versions) around printed circuit boards.
- Do not touch the components or conductors on a printed circuit board with your hands or with conductive devices.

To prevent damage to electronic components caused by improper handling, read and observe the precautions in Woodward manual **82715**, *Guide for Handling and Protection of Electronic Controls, Printed Circuit Boards, and Modules*.

Follow these precautions when working with or near the control.

1. Avoid the build-up of static electricity on your body by not wearing clothing made of synthetic materials. Wear cotton or cotton-blend materials as much as possible because these do not store static electric charges as much as synthetics.
2. Do not remove the printed circuit board (PCB) from the control cabinet unless absolutely necessary. If you must remove the PCB from the control cabinet, follow these precautions:
 - Do not touch any part of the PCB except the edges.
 - Do not touch the electrical conductors, the connectors, or the components with conductive devices or with your hands.
 - When replacing a PCB, keep the new PCB in the plastic antistatic protective bag it comes in until you are ready to install it. Immediately after removing the old PCB from the control cabinet, place it in the antistatic protective bag.

Regulatory Compliance

European Compliance for CE Marking:

EMC Directive Declared to Directive 2014/30/EU of the European Parliament and of the Council of 26 February 2014 on the harmonization of the laws of the Member States relating to electromagnetic compatibility (EMC)

ATEX – Potentially Explosive Atmospheres Directive: Directive 2014/34/EU on the harmonisation of the laws of the Member States relating to equipment and protective systems intended for use in potentially explosive atmospheres
Zone 2, Category 3, Group II G, Ex nA IIC T4 Gc IP66

Other European and International Compliance:

Machinery Directive: Compliant as partly completed machinery with Directive 2006/42/EC of the European Parliament and the Council of 17 May 2006 on machinery.

Pressure Equipment Directive: Compliant as “SEP” per Article 4.3 to Pressure Equipment Directive 2014/68/EU on the harmonisation of the laws of the Member States relating to the making available on the market of pressure equipment.

IECEX: Certified for use in hazardous locations: IECEx CSA 11.0017X (Ex nA) for Zone 2, Category 3, Group II G, Ex nA IIC T4 Gc IP66 or Zone 2, Category 3 G, Ex nA IIC T4 Gc IP66

North American Compliance:

CSA: CSA Certified for Class I, Division 2, Groups A, B, C, & D, T4 at 85 °C Ambient. For use in Canada and the United States.

Special Conditions for Safe Use

Wiring must be in accordance with North American Class I, Division 1 or 2, or European Zone 1, Category 2 or Zone 2, Category 3 wiring methods as applicable, and in accordance with the authority having jurisdiction.

Field wiring must be suitable for at least 85 °C and 10 °C above the maximum fluid and ambient temperatures.

The CPC-DX must be used in an ambient temperature range from –40 to +85°C (-40 to + 185°F).

The working fluid temperature must be in range +15 to +70°C (+59 to 158°F).

Connect external safety ground terminal to earth ground.

Compliance with the Machinery Directive 2006/42/EC noise measurement and mitigation requirements is the responsibility of the manufacturer of the machinery into which this product is incorporated.

The external ground lugs shown on the installation drawing must be properly connected to ensure equipotential bonding. This will reduce the risk of electrostatic discharge in an explosive atmosphere.

AND

Any cleaning by hand or with water spray must be performed while the area is known to be non-hazardous to prevent an electrostatic discharge in an explosive atmosphere.

 **WARNING**

Explosion Hazard—Do not connect or disconnect while the circuit is live unless the area is known to be non-hazardous.

Substitution of components may impair suitability for Class I, Division 1 or 2 or Zone 2 applications.

 **AVERTISSEMENT**

Risque d'explosion—Ne pas raccorder ni débrancher tant que l'installation est sous tension, sauf en cas l'ambiance est décidément non dangereuse.

La substitution de composants peut rendre ce matériel inacceptable pour les emplacements de Classe I, applications Division 1 ou 2 ou Zone 2.

Chapter 1.

General Information

Introduction

Table 1-1. Terms and Definitions

CPC-DX	Current to Pressure Converter Dual Transfer Skid
CPC-II	Current to Pressure Converter
DCS	Distributed Control System
In Control	The unit actually controlling the position of the servo system
LLC	Load Leakage Compensation
Master / Slave	The unit designated as the Master has yielded control to the other unit (Slave) by link between the two CPC-IIs. The Unit designated, as the Master will take control during CPC-DX startup.
Not In Control	The unit acting as the backup to the In Control unit
SW	wrench size [mm]

To aid with calibration, pressure gages are provided on the skid assembly (see Figure 1-2). These gages indicate which unit is in control. The unit in control will show an operating value (typically 0.8 bar) higher than the slave unit during normal operation.

Table 1-2. Woodward Reference Literature

Product Manual 26615	CPC-II Current-to-Pressure Converter with Enhanced Dynamics
CPC-II Unit replacement Procedure 26824	CPC-DX Current to Pressure Converter Dual Transfer Skid, CPC-II Unit replacement procedure
Manual 25071	Oils for Hydraulic Controls
Reference Manual 26455	Woodward Energy Segment Customer Publications: Cross-Reference by Application Revision Status & Distribution Restrictions
Manual 82715	Guide for Handling and Protection of Electronic Controls, Printed Circuit Boards, & Modules
Manual 25075	Commercial Preservation Packaging for Storage of Mechanical-Hydraulic Controls

System Description

The Woodward CPC-DX Dual Transfer Skid is a dual redundant, Current-to-Pressure Converter system. Its typical application is to control steam valves by interfacing redundant turbine controllers or signals to a single steam control valve servo mechanism.

The system offers redundant operation of a steam valve servo assembly in applications where it is not desirable for failure of the turbine control system and/or pressure converter to interrupt the operation of the turbine.

NOTICE

CPC-DX Dual Transfer Skid can be used also in other applications. Contact with Woodward for more information and guidance for use in different systems other than that described within this document.

! WARNING

The “*Master/Slave*” indication shows only which unit is designated for primary operation from the control system. Because it is possible for the slave to be in control, it is necessary to confirm which unit is controlling the skid output pressure via the external gages and the “In Control” discrete output status.

NOTICE

For a full description of the CPC-II, see Woodward manual **26615**.

! WARNING

For the online CPC-II replacement procedure, see Woodward manual **26824**

The CPC-DX Dual Transfer Skid supplies a precise and stable hydraulic control pressure proportional to the (4 to 20) mA input current signal. The system described in this manual consists of a skid-mounted arrangement of two CPC-II's operating through a transfer valve assembly as shown in Figure 1-1.

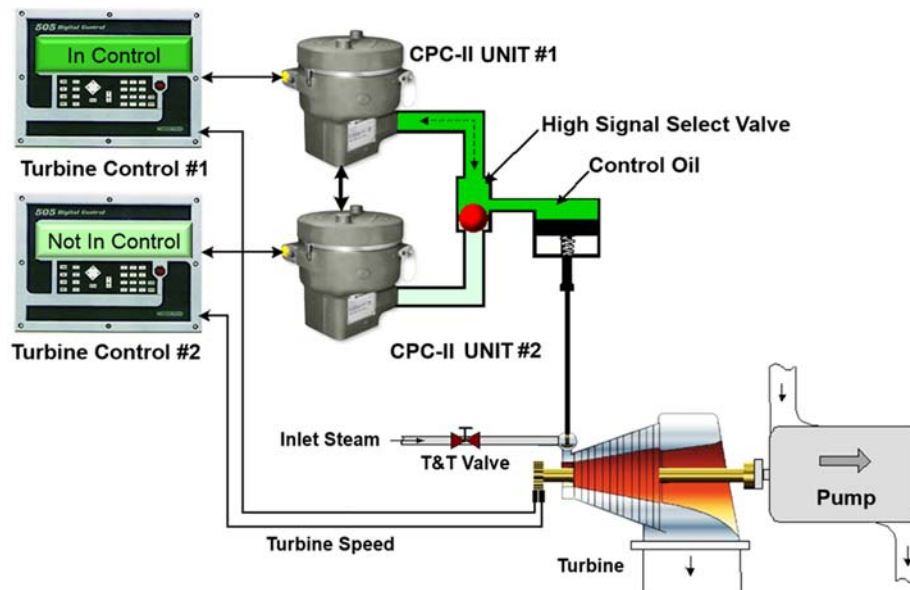

Figure 1-1. Basic CPC-DX Application and Configuration

The electronics and software design of the CPC-II provides continuous communication between two CPCs to communicate their health and control status between units. Should there be a failure of the In Control converter or loss of signal its turbine control, the Not In Control unit will detect the fault condition automatically and assume control of the skid output pressure. This occurs without required intervention by the turbine control system.

The two outputs from the turbine control system(s) provide the setpoint inputs to the two CPC-II converters 1 and 2.

The user can also switch between converters at any time to verify unit operation or to distribute run time among the two converters.

Additionally the system allows for the field replacement of CPC-II unit in the event of a failure, without the need to stop the turbine or control system.

While running, the *Not in Control* unit continuously biases its pressure output to track at a fixed level below the In Control unit. This fixed pressure differential applied across the internal high signal select valve holds the switching valve in the position allowing the In Control unit full authority to raise and lower the control pressure based on its setpoint. If the In Control unit or its controller fails, the failsafe configuration causes the converter output pressure to fall, allowing the high signal select valve to shift to the operational unit. When this occurs, the *Not In Control* unit eliminates its pressure bias, which switches the high signal select valve to the opposite position quickly. Since the transitioning converter only needs to change pressure by the bias amount, this tends to maintain the skid output pressure, with minimum transient impact to the operated steam valve position. An additional benefit of the continuous tracking feature of the *Not In Control* unit is continuous demonstration of its availability to assume control when needed.

The CPC-DX uses a specially designed fast-switching high signal select valve to ensure minimal control switchover time and minimal system control pressure disturbance.

Design Characteristics

The skid assembly has been designed to offer maximum reliability, especially for critical steam turbine applications, and features include:

- Ease of installation
- Minimum hydraulic connections, reducing the potential for oil leakage
- Compact design
- Rapid control switchover (transfer) time
- 4 (four) Isolation valves which allow each CPC-II to be fully calibrated and checked before switching it to on-line service
- Dirt tolerant shuttle valve
- Online diagnostics and automatic switchover logic
- On-line replacement capability to safely and reliably disable, remove or replace the one of the CPC-II without the need to stop the turbine or control system.
-

Construction

The CPC-DX is a complete packaged and tested assembly which consists of two Woodward current-to-pressure converters (CPC-II's) connected together to a single manifold with all interconnect piping, gauges and wiring included and factory tested.

The two CPC-II's are mounted to an anodized aluminum manifold containing the transfer valve, isolation valves and pressure test points. The manifold and CPC-II's are mounted to a steel support frame.

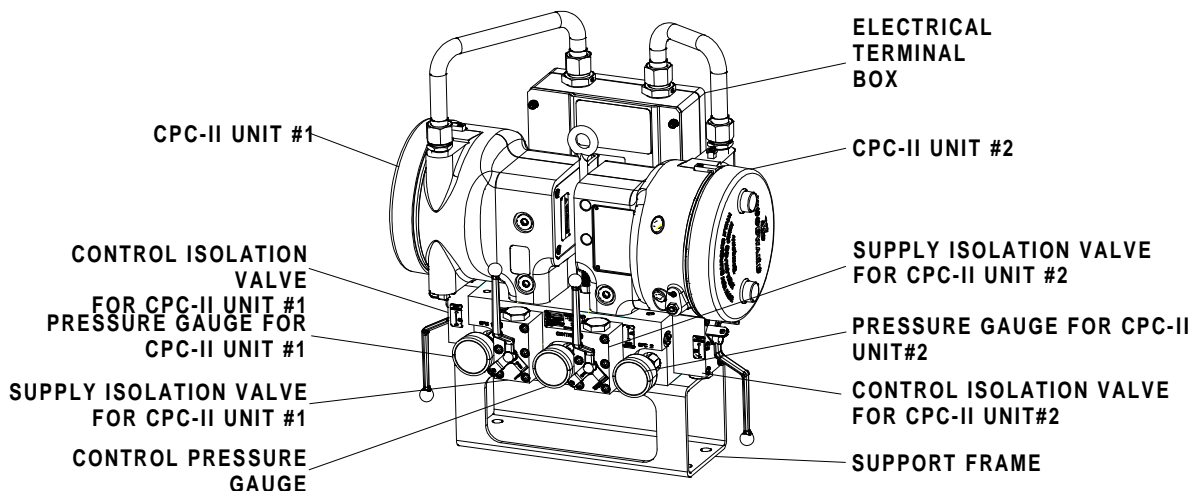

Figure 1-2. CPC-DX Main Components.

The complete assembly is designed for use in a hazardous environment, see the Regulatory Compliance specifications for more details.

Integrated oil pressure gauges allow the user to visually verify which CPC-II is in control and verify the CPC-DX output oil header pressure level. The CPC II discrete output status contacts can also be used to provide verification of operation or shutdown via status lamps and/or the plant DCS to assist with system health monitoring.

The CPC-DX ports are represented as **SUPPLY** for the supply oil port, **DRAIN CPC 1** and **DRAIN CPC 2** for the drain (tank) lines, and **CONTROL** for the CPC-DX control oil connection to the control system as shown in Figure 1-5.

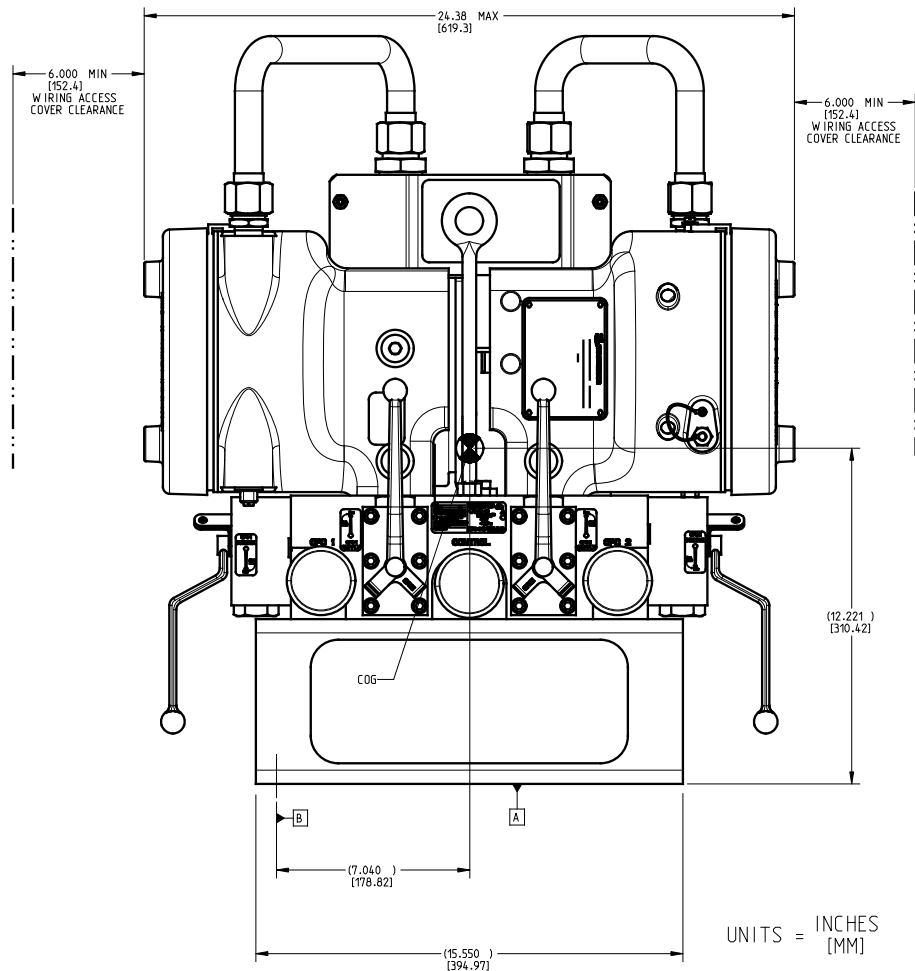

Figure 1-3. CPC-DX Installation Drawing Front view

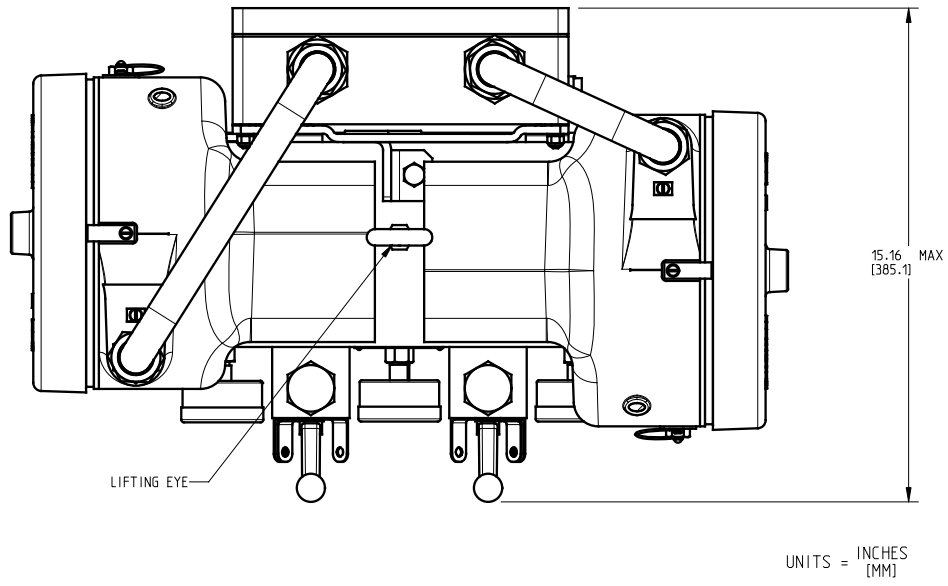

Figure 1-4. CPC-DX Installation Drawing, Top view

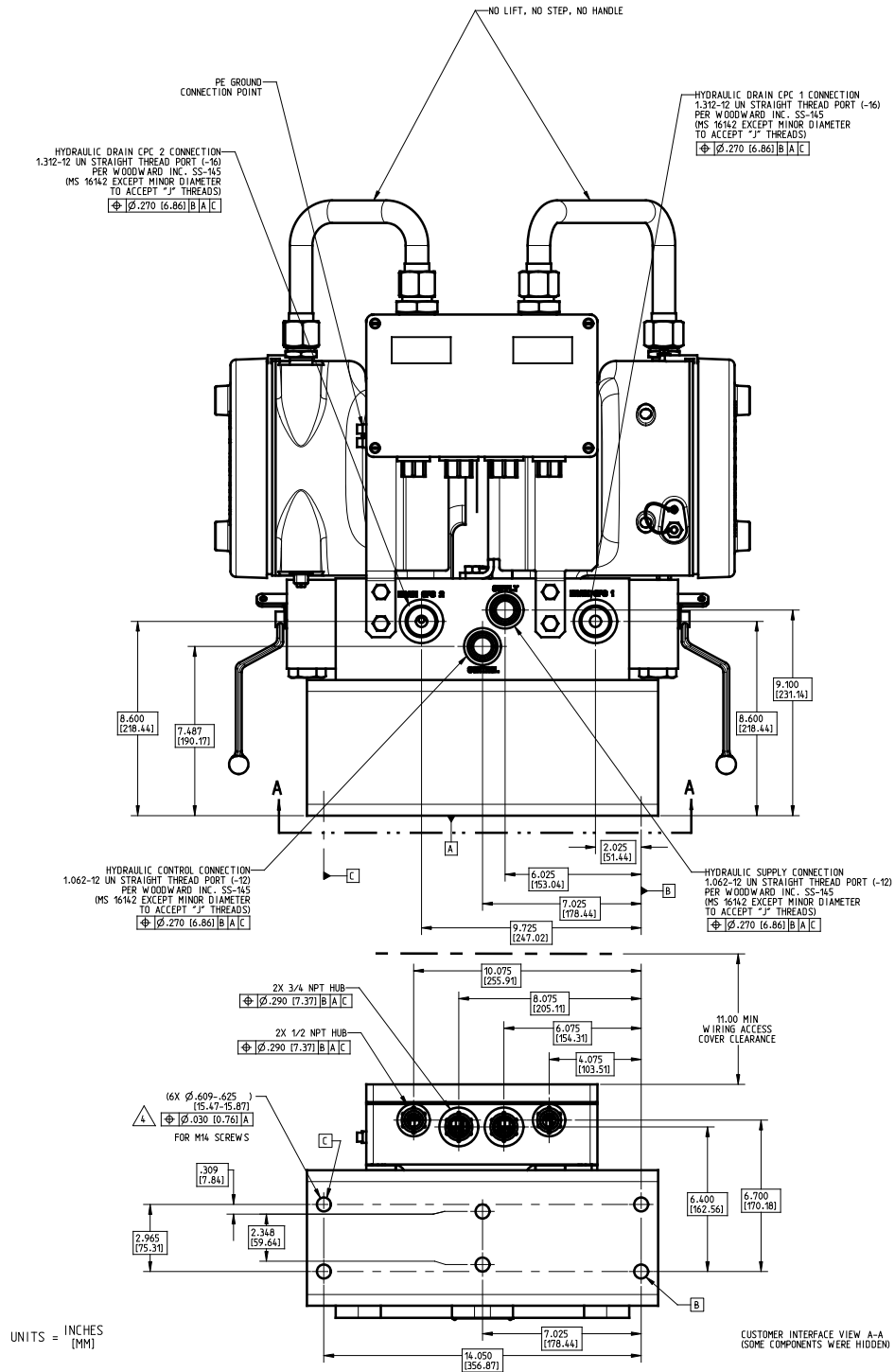

Figure 1-5. CPC-DX customer interface

The wiring for the CPC-DX skid is shown in Figures 1-6 and 1-7. The required minimum wiring for proper operation is as follows:

- Supply Power (18 to 32) V (dc), 24 V (dc) nominal for each converter
- Analog Setpoint1 (4 to 20) mA into 200 Ω . 70 dB CMRR. Common
- Mode Voltage Range: ± 100 V for each converter
- Master Designation Discrete Input + & - for each converter (described in chapter 3)
- Redundant Link Input and Output for each unit (factory provided)

The remaining signals shown on the wiring diagram are optional.

1. It is important that during operation, the setpoint signals to both converters are nearly identical.

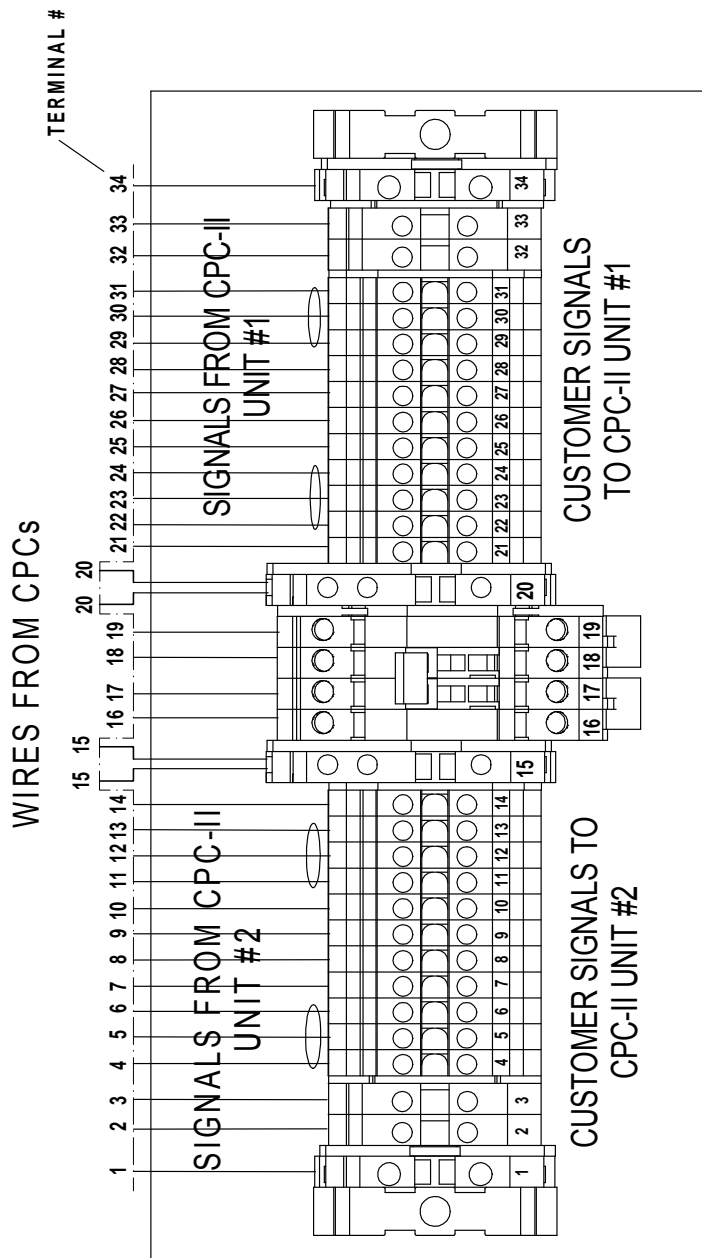

Figure 1-6. CPC-DX Main Terminal Box, Wiring Diagram

CONNECTIONS CHART

TERMINAL NO	CONDUCTOR WIRE COLOUR	WIRE SIZE (AWG)	SIGNAL	
1	GREEN/YELLOW	14	CPC 2 GROUNDING	CPC 2 CUSTOMER SIGNALS
2	RED	14	CPC 2 24 VDC POWER +	
3	BLACK	14	CPC 2 24 VDC POWER -	
4	GREEN/WHITE	22	CPC 2 ANALOG IN SET POINT +	
5	WHITE/BLUE	22	CPC 2 ANALOG IN SET POINT -	
6	SHIELD	22	CPC 2 ANALOG IN SET POINT SHLD	
7	BROWN	24	CPC 2 DISCRETE OUT 1 SHUTDOWN +	
8	ORANGE	24	CPC 2 DISCRETE OUT 1 SHUTDOWN -	
9	YELLOW	24	CPC 2 DISCRETE OUT 1 ALARM +	
10	GREEN	24	CPC 2 DISCRETE OUT 1 ALARM -	
11	BLACK/WHITE	22	CPC 2 ANALOG OUT -	
12	WHITE/GREEN	22	CPC 2 ANALOG OUT +	
13	SHIELD	22	CPC 2 ANALOG OUT SHLD	
14	WHITE	24	CPC 2 DISCRETE IN 1 MASTER DESIGNATION +	
15	GRAY	24	CPC 2 DISCRETE IN GND	
	VIOLET	24	CPC 1 DISCRETE OUT 3 REDUNDANT LINK OUTPUT -	
16	BLACK	24	CPC 2 DISCRETE IN 2 REDUNDANT LINK INPUT +	
17	BLUE	24	CPC 1 DISCRETE OUT 3 REDUNDANT LINK OUTPUT +	
18	BLUE	24	CPC 2 DISCRETE OUT 3 REDUNDANT LINK OUTPUT +	
19	BLACK	24	CPC 1 DISCRETE IN 2 REDUNDANT LINK INPUT +	
20	VIOLET	24	CPC 2 DISCRETE OUT 3 REDUNDANT LINK OUTPUT -	
	GRAY	24	CPC 1 DISCRETE IN GND	
21	WHITE	24	CPC 1 DISCRETE IN 1 MASTER DESIGNATION +	CPC 1 CUSTOMER SIGNALS
22	SHIELD	22	CPC 1 ANALOG OUT SHLD	
23	WHITE/GREEN	22	CPC 1 ANALOG OUT +	
24	BLACK/WHITE	22	CPC 1 ANALOG OUT -	
25	GREEN	24	CPC 1 DISCRETE OUT 1 ALARM -	
26	YELLOW	24	CPC 1 DISCRETE OUT 1 ALARM +	
27	ORANGE	24	CPC 1 DISCRETE OUT 1 SHUTDOWN -	
28	BROWN	24	CPC 1 DISCRETE OUT 1 SHUTDOWN +	
29	SHIELD	22	CPC 1 ANALOG IN SET POINT SHLD	
30	WHITE/BLUE	22	CPC 1 ANALOG IN SET POINT -	
31	GREEN/WHITE	22	CPC 1 ANALOG IN SET POINT +	
32	BLACK	14	CPC 1 24 VDC POWER -	
33	RED	14	CPC 1 24 VDC POWER +	
34	GREEN/YELLOW	14	CPC 1 GROUNDING	

Figure 1-7. CPC-DX Main Terminal Block Connections List

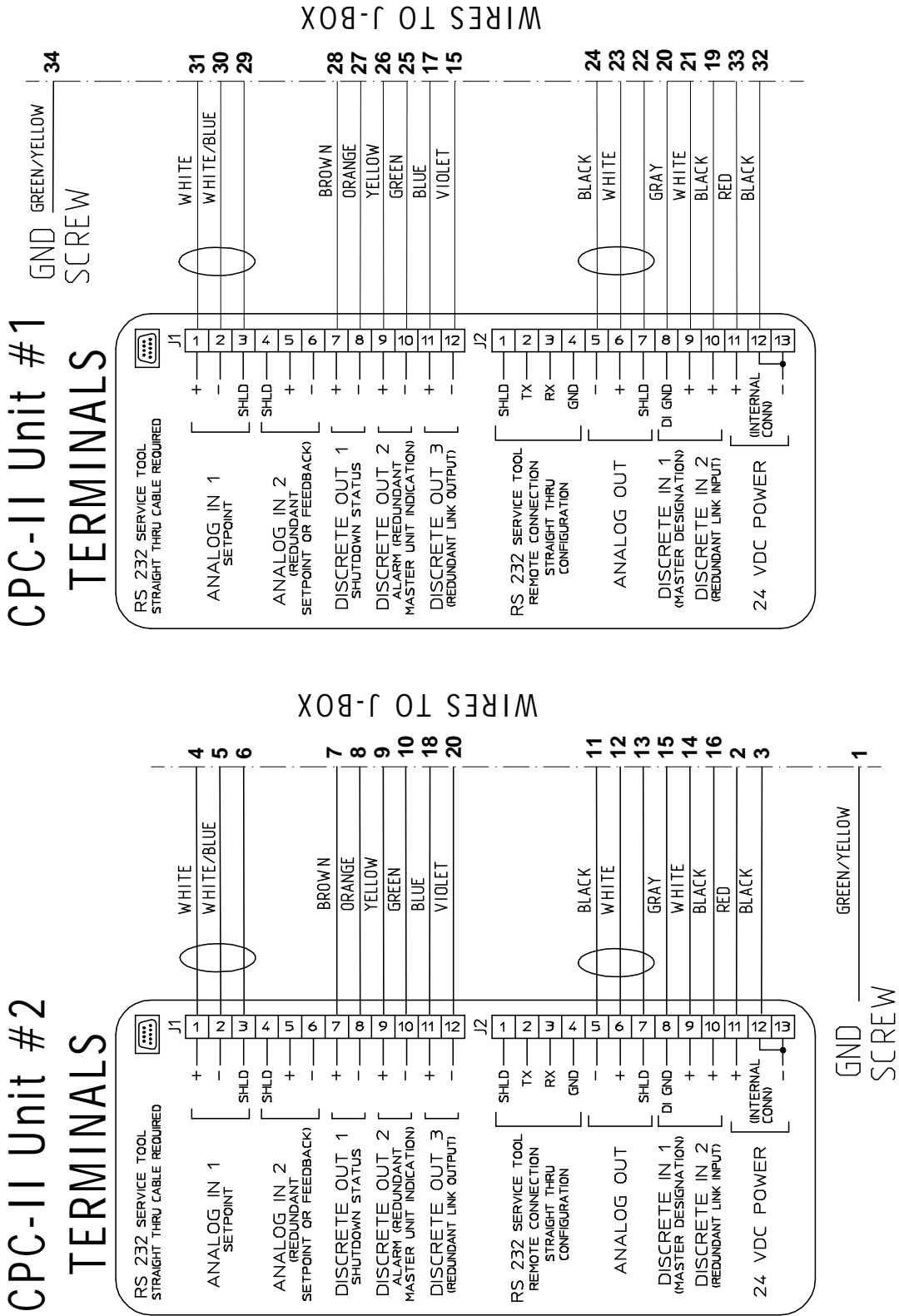

Figure 1-8. Internal CPC wiring diagram

Chapter 2. System Specifications

Table 2-1. Environmental

Ambient Temperature	-40 to +85°C (-40 to + 185°F)
Humidity	95 % relative humidity
Oil Temperature	+15 to +70°C (+59 to 158°F)
Oil Viscosity	10 to 55 centistokes
Max. Surface Temperature	85 °C
Vibration	US MIL-STD 810F, M514.5A, Cat. 4 (0.015 G ² /Hz, 10 to 500 Hz, 1.04 Grms)
Shock	US MIL-STD-810C method 516.2, procedure 1 (10 G Peak, 11 ms duration, saw tooth)
Ingress Protection	IP66 per IEC EN 60529 with IECEx conditioning as described by IEC 60079-0:2011 and IEC 60079-15:2010

Table 2-2. Physical

Height x Width x Depth	Approx. (696 x 619.3 x 385.1) mm /(27.40 x 24.38 x 15.16) inch
Weight	Approx. 81.6 kg (180 lbs) without oil
Mounting	6x8 holes Ø.609-.625 (15.47-15.87 mm) (for M14 screws), see Figure 1-3.

Table 2-3. Electrical

Connections	Junction box terminals suitable for (0.8 to 3) mm ² / (12 to 18) AWG stranded wire
Cable Entries	Entry power supply wires via 2 x 1/2 NPT CONDUIT HUB and signal wires via 2 x 3/4 NPT CONDUIT HUB
Supply Voltage	(18 to 32) V (dc), 24 V (dc) nominal (use cable 3 mm ² / 12 AWG)
Power Consumption	25 W steady state Transient 90 W (2 s maximum)
Setpoint Signal	(4 to 20) mA into 200 Ω. 70 dB CMRR. Common Mode Voltage Range: □100 V
Redundant Input or Feedback Signal	(4 to 20) mA into 200 Ω. 70 dB CMRR. Common Mode Voltage Range: ±100 V
Analog Output Signal	(4 to 20) mA. Maximum external load: 500 Ω Accuracy ±0.5 % of full scale
Discrete Output Signal	Configurable for NO or NC, 0.5 A at 24 V (dc), max. 32 V (dc) 0.5 A inductive at 28 V (dc) 0.2 Henry

Note: For more electrical information, see CPC-II manual **26615**.

Table 2-4. Hydraulic

HYDRAULIC SUPPLY	connection 1.062-12 UN straight thread port
HYDRAULIC CONTROL	connection 1.062-12 UN straight thread port
HYDRAULIC DRAIN CPC-II Unit #1	connection 1.312-12 UN straight thread port
HYDRAULIC DRAIN CPC-II Unit #2	connection 1.312-12 UN straight thread port

Note: For more details, see Figure 1-5.

Note: Hydraulic ports per Woodward Inc. SS-145 (MS 16142 except minor diameter to accept “J” threads)

Table 2-5. CPC-DX Maximum Input/Supply Pressure

CPC-DX Models	Maximum Input/Supply Pressure
SKID 10 BAR	10 bar / 145 psi
SKID 25 BAR	25 bar / 363 psi



WARNING Hydraulic supply pressure stability must be within $\pm 5\%$ of the minimum control pressure.

Tank Pressure	2 bar maximum or 30 % of the minimum control pressure whichever is lower
Recommended Fluid	Mineral or synthetic based oils may be used. Woodward oil recommendations per manual 25071 .
Oil Cleanliness	ISO 4406:99 code 22/20/16 max fluid cleanliness or better is recommended for optimum reliability, code 19/17/14 preferred

Table 2-6. Hydraulic parameters

NAME	CPC-DX SKID 10 BAR Model	CPC-DX SKID 25 BAR Model
Maximum Input / Supply Pressure	10 bar / 145 psi	25 bar / 363 psi
Minimum Output / Control Pressure at setpoint 4 mA ⁽¹⁾	1.5 bar (22 psi)	1.5 bar (22 psi)
Maximum regulating Output/Control Pressure at setpoint 20 mA ⁽²⁾	7 bar (101 psi)	17.5 bar (254 psi)
Max Output / Control flow ⁽³⁾	23 l/min (6 US gpm)	23 l/min (6 US gpm)
Max Internal leakage ⁽⁴⁾	31 l/min (8.2 US gpm)	49 l/min (13 US gpm)



⁽²⁾ The maximum control pressure setting must be less than 70% of the supply pressure for optimum dynamic performance.



⁽³⁾ The default offset value of 0.8 bar is sufficient to ensure CPC-DX operation with flow to the control line up to 23 l/min (6 US gpm) at oil viscosity up to 55 cSt. If the application requires higher flow rates to the control line or higher oil viscosity usage, the offset pressure between units will need to be increased.



⁽⁴⁾ The maximum internal leakage determined with Max control pressure and oil viscosity 20 cSt.

Internal leakage and control pressure correlation – see Figure 2-1 and 2-2 below.

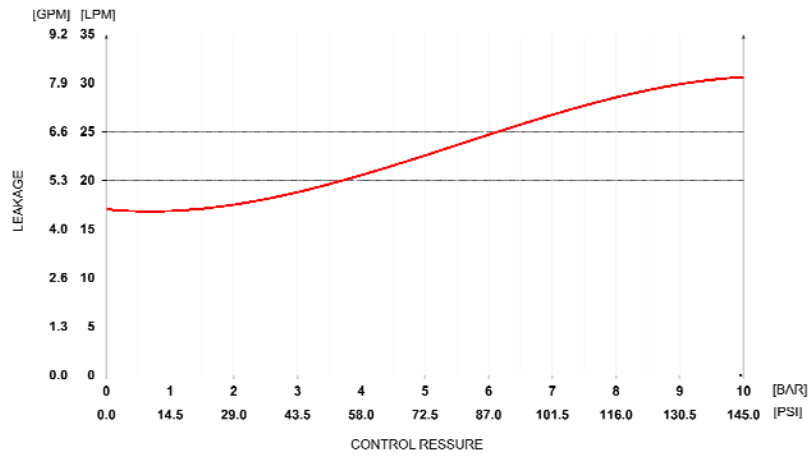

Figure 2-1. Internal Leakage, CPC-DX Skid, 10 bar supply pressure, oil viscosity 20 cSt;

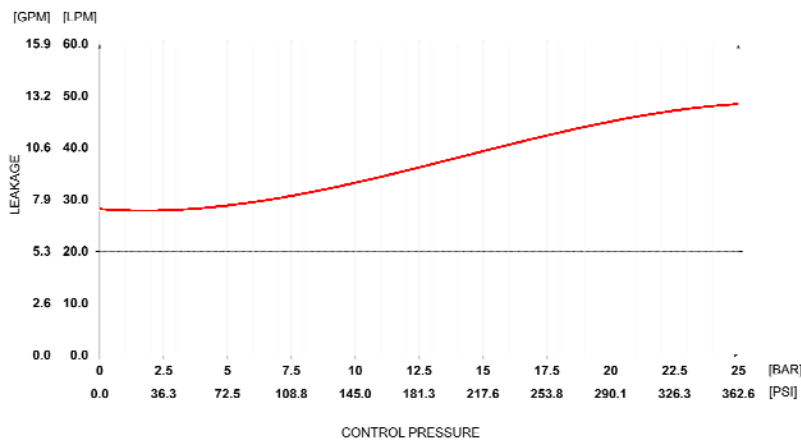

Figure 2-2. Internal Leakage, CPC-DX Skid, 25 bar supply pressure, oil viscosity 20 cSt;

Chapter 3. Installation

Receiving Instructions

! WARNING

Do not connect/disconnect/substitute components
WARNING - Explosion Hazard—Do not remove covers or connect/disconnect electrical connectors unless power has been switched off or the area is known to be non-hazardous.

Substitution of components may impair suitability for Class I, Division 2 or Zone 2 applications.

AND

AVERTISSEMENT - Risque d'explosion— Ne pas enlever les couvercles, ni raccorder / débrancher les prises électriques, sans vous en assurez auparavant que le système a bien été mis hors tension; ou que vous situez bien dans une zone non explosive.

La substitution de composants peut rendre ce matériel inacceptable pour les emplacements de Classe I, applications Division 2 ou Zone 2.

! WARNING

Special Conditions for Safe Use:

Wiring must be in accordance with North American Class I, Division 1 or 2, or European Zone 1, Category 2 or Zone 2, Category 3 wiring methods as applicable, and in accordance with the authority having jurisdiction.

Field wiring must be suitable for at least 85 °C and 10 °C above the maximum fluid and ambient temperatures.

The CPC-DX must be used in an ambient temperature range from –40 to +85°C (-40 to + 185°F).

The working fluid temperature must be in range +15 to +70°C (+59 to 158°F).

Connect external safety ground terminal to earth ground.

Compliance with the Machinery Directive 2006/42/EC noise measurement and mitigation requirements is the responsibility of the manufacturer of the machinery into which this product is incorporated.

The external ground lugs shown on the installation drawing must be properly connected to ensure equipotential bonding. This will reduce the risk of electrostatic discharge in an explosive atmosphere.

AND

Any cleaning by hand or with water spray must be performed while the area is known to be non-hazardous to prevent an electrostatic discharge in an explosive atmosphere.

! WARNING**Hearing Protection**

Due to typical noise levels in turbine (or engine) and environments, hearing protection should be worn when working on or around the CPC-DX

! WARNING**Hot Surfaces**

The surface of this product can become hot enough or cold enough to be a hazard. Use protective gear for product handling in these circumstances. Temperature ratings are included in the specification section of this manual.

The CPC-DX Dual Transfer Skid assembly is carefully packaged at the factory to protect it from damage during shipping. However, careless handling may result in damage to the unit. If any damage to the CPC-DX is discovered, notify both the shipping agent and Woodward. When unpacking the CPC-DX, do not remove the hydraulic blanking plugs until you are ready to mount the unit to hydraulic lines.

! WARNING**Lifting Locations**

Do not lift or handle the CPC-DX by any conduit. Lift or handle the CPC-DX only using the provided eyebolt.

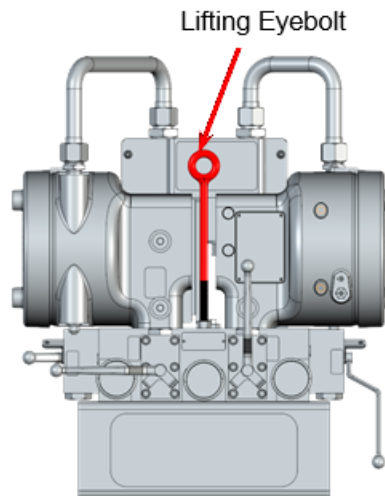

Figure 3-1. CPC-DX Lifting eyebolt location.

Mounting Instructions

The CPC-DX assembly is designed to be attached to a horizontal structure via the four mounting screws. The CPC-DX should be mounted as close as possible to the controlled system (servo) to minimize the hydraulic control line length and oil volume to achieve optimum system response.

Avoid mounting CPC-DX near heat sources and provide adequate ventilation.

Mount CPC-DX using six (6) M14 metric size screws (or equivalent size) and 6 washers (washers provided with unit). See Figure 1-5 for bolts pattern.

IMPORTANT

When installing the CPC-DX pay attention to clearances required to remove/replace component parts.

Allow space for removal of the side covers, for access to the terminal blocks and to see the status LEDs on the printed circuit board inside CPC-II.

Hydraulic Connections

There are four hydraulic ports on the backside of the CPC-DX manifold. These are clearly marked **SUPPLY** for the supply oil port, **DRAIN CPC 1** and **DRAIN CPC 2** for the drain (tank) line, and Hydraulic **CONTROL (HC)** for the control oil connection to the servo system.

Prior to connecting the hydraulic lines to the skid, **ALL** hydraulic lines should be thoroughly flushed to prevent contamination from entering the CPC-DX.

A high capacity, serviceable filter is recommended upstream of the CPC-DX supply port (see recommended hydraulic cleanliness in Hydraulic Specification section).

The pump capacity must be large enough to supply the required slew rate of the attached servo system with some margin. If the supply pressure to the converter sags during a transient, this will impact the stability and overall performance of the system.

IMPORTANT

Install valves in drain line close to CPC-DX. It will prevent hydraulic oil return from line during CPC unit replacement.

Electrical Connections

Apply local procedures, codes, and directives for installing electrical/electronic equipment and, where applicable, for installing explosion proof devices in hazardous environments.

WARNING

Due to the hazardous location listings associated with this product, proper wire type and wiring practices are critical to operation.

The Electrical Terminal Box has four entry points for the customer-wiring interface. Refer to the wiring diagram shown in Figure 1-7 and connection chart Figure 1-8. Use the 2 x 1/2 NPT CONDUIT HUB for electrical power supply wires and 2 x 3/4 NPT CONDUIT HUB for signal wires.

Wiring Requirements:

- Individually shielded twisted pair cable
- Keep this and all other low level signal cables separated from input power cables to avoid unnecessary coupling (noise) between them.
- Wire Gauge Range: (0.8 to 3) mm² / (12 to 18) AWG

Use screened cable for all analog signals, and avoid routing power supply wires and signal wires within the same conduit.

Input Power

The CPC-DX requires an electrical power source capable of supplying the necessary output voltage and current at full transient conditions. For each CPC-II, the electrical power supply should be able to provide 2 A at 24 V (dc) continuously, with a peak of 5 A for two seconds.

Use a separate electrical power source to each CPC-II. Use terminal blocks 2, 3, 32 and 33 to supply power.

Recommended fuse ratings or circuit breakers.

Table 3-1. Fuse/Breaker Requirements

Component	Input Voltage	Maximum Current	Maximum Power	Maximum Fuse/C.B. Rating
CPC-II UNIT #1	(18 to 32) V (dc), 24 V (dc) nominal	5 A	90 W (2 s)	6 A
CPC-II UNIT #2	(18 to 32) V (dc), 24 V (dc) nominal	5 A	90 W (2 s)	6 A

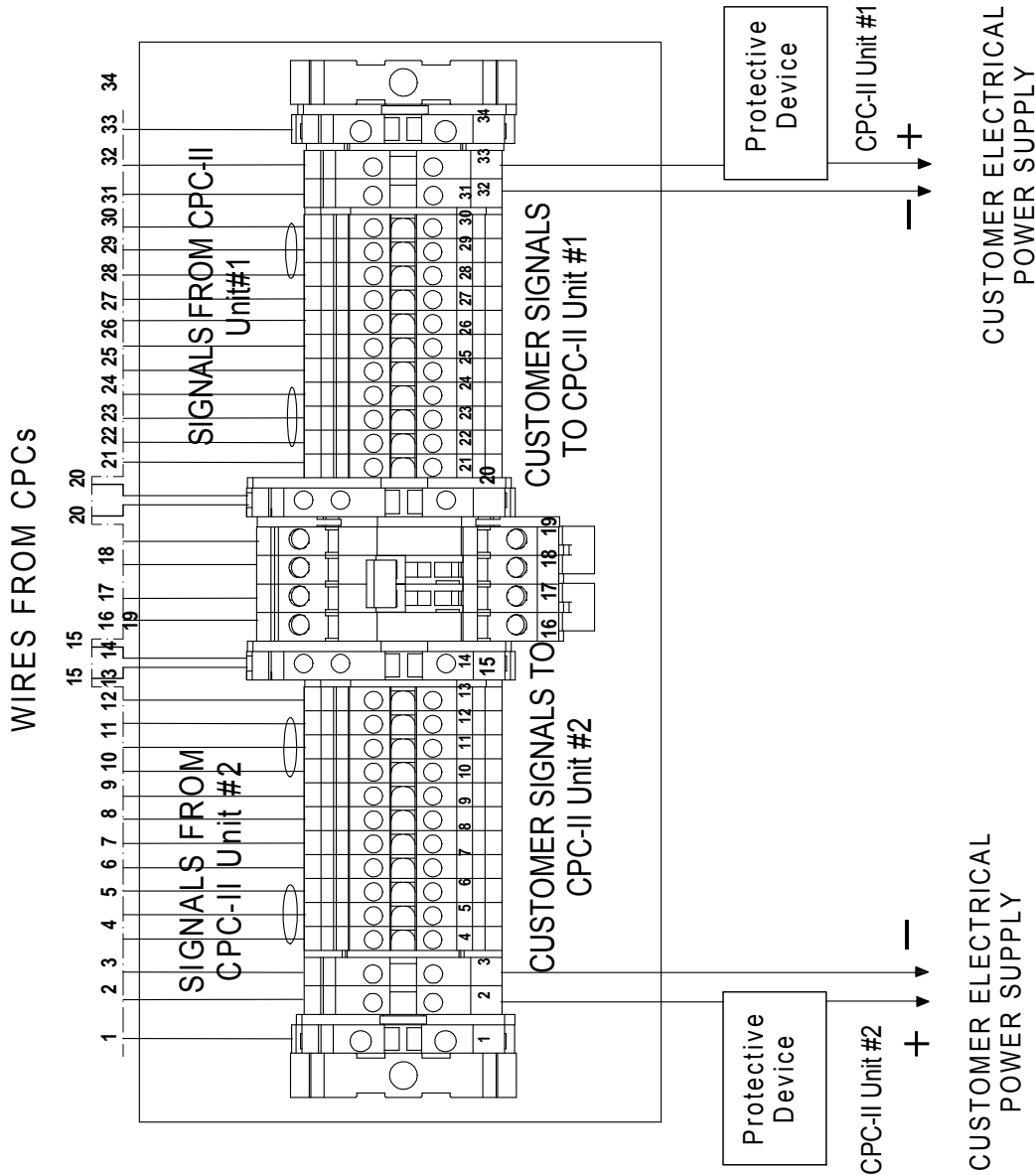

Figure 3-2. Power Supply Input Connections

For additional electric requirements, see Woodward manual **26615**.

Discrete Inputs

The CPC-II has two discrete inputs. External power is not necessary for these inputs as the isolation is provided internally. The discrete inputs have an internal pull-up resistor and are inverted at the processor, such that an open circuit is the passive low state. The high state is achieved when the input is pulled low by an external contact to the isolated ground terminal provided. There are two inputs and one ground terminal (DI GND) provided, so it is necessary to share the one ground if both inputs are used.

Discrete Input 1, Master Designation Input determines if the CPC-II is the master or slave in a redundant configuration. Use a switch relay to designate master/slave unit.

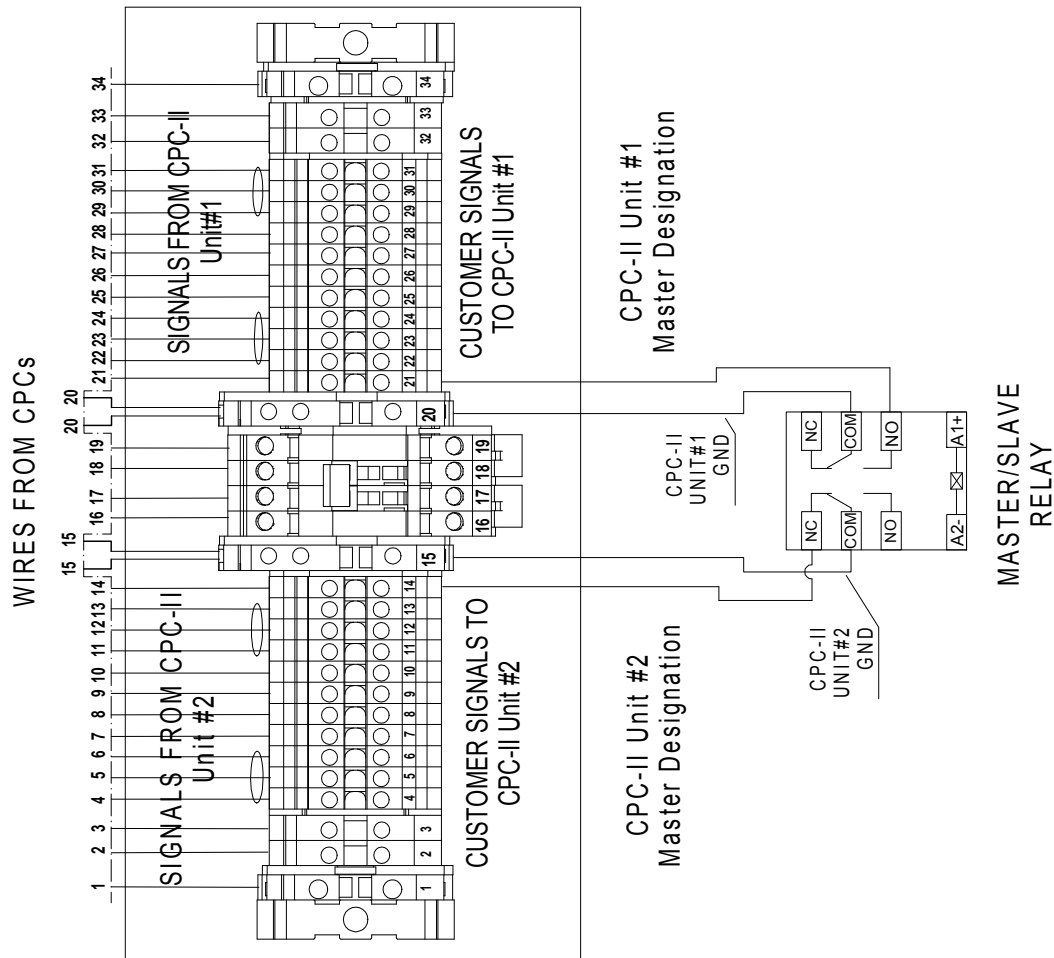

Figure 3-3. Wiring Connections for Master Designation

Discrete Input 2, Redundant Mate In Control is dedicated to a redundant pair configuration. The two CPC-IIs communicate which unit is in control via a pulse train on these discrete lines. Discrete Input 2 must be wired to Discrete Output 3 of the other unit. This wiring is provided from the factory, but must remain in place for the switching performance to operate as designed.



WARNING

During CPC-DX unit configuration be sure that:

- BOTH units aren't configured as a "MASTER"
- BOTH units aren't configured as a "SLAVE"

Above combinations can cause significant performance decrease when performing unit to unit control switchover.

Discrete Outputs

Discrete Output 1 and 2, can be configured to enunciate upon detection of the following conditions:

- Any Alarm Indication
- Any Shutdown Indication
- Any Alarm or Shutdown Indication
- Operation as Master
- In Control

The Default Discrete Output settings for CPC-DX SKID are:

Discrete Output 1: Configured as Any Alarm and Shutdown Status.

Discrete Output 2: Configured as In Control/Not in Control Status.

Discrete Output 3, is dedicated to the pulse train output for use in redundant configurations. It cannot be configured by the user.

Unit Grounding

The junction box must be grounded using the designated PE ground connection point. PE ground connection point is located on the sidewall of the junction box.

PE GROUND
CONNECTION POINT

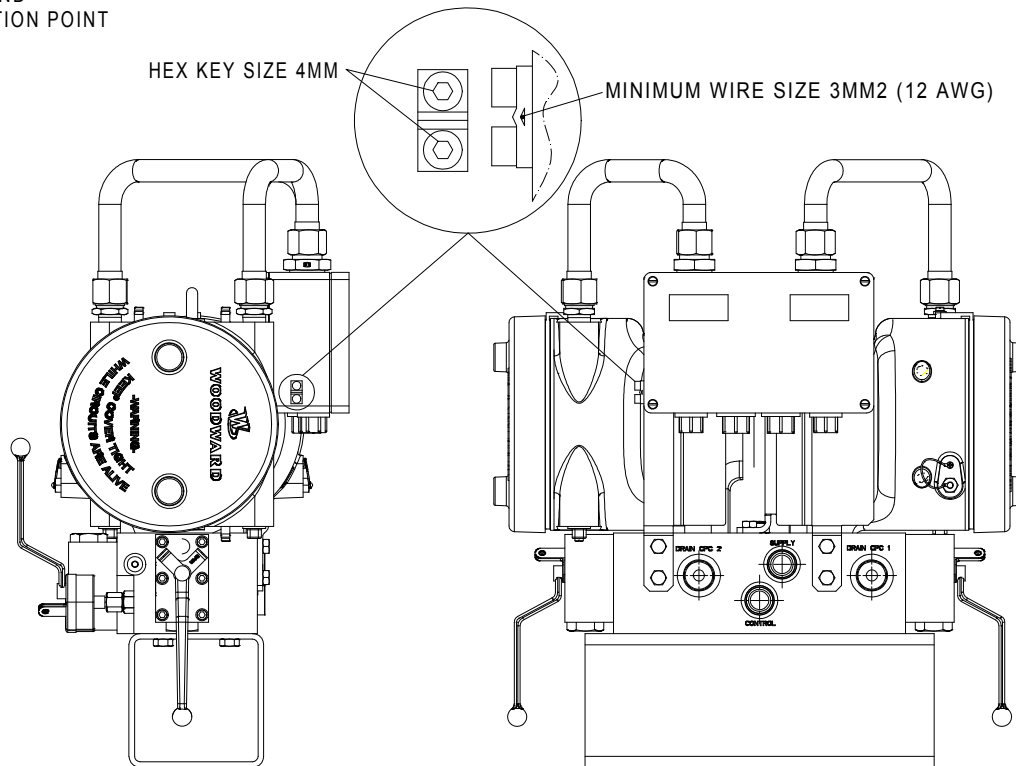

Figure 3-4. PE ground connection localization and details

NOTICE

Do not connect any cable grounds to “instrument ground”, “control ground”, or any non-earth ground system. Make all required electrical connections based on the wiring diagrams.

For the PE connection, use the required type wire (typically green/yellow, 3 to 6 mm² / 12 to 10 AWG) as necessary to meet the installation safety ground requirements. Torque the ground lugs to 5.1 Nm (45 lb-in).

Shielded Wiring

Use shielded cable for all analog signals and the RS-232 service port. Terminate shields as shown in the following sections. Avoid routing power supply wires and signal wires within the same conduit unless properly shielded. When bundling the field wiring inside the unit, separate the unshielded power and discrete inputs/outputs from the shielded analog signals and RS-232.

Wiring

The junction box CPC-DX has two 3/4 inch NPT and two 1/2 inch NPT wiring entries (see Figure 1-5).

The cable insulation must have a temperature rating of at least $T_{amb} + 10\text{ }^{\circ}\text{C}$ above the maximum ambient or fluid temperature (whichever is greater).

1. Strip the cable insulation (not the wire insulation) to expose 12 cm of the conductors. Strip the wire insulation 5 mm from each conductor. Mark the wires according to their designation and install connectors, if required.
2. Remove the top access cover from junction box. Pass the wires through the appropriate conduit hub and attach to the terminal blocks in accordance with the wiring diagram (see Figure 1-7). Tighten the terminal block flange screws to $0.5 \pm 0.1\text{ Nm}$ ($4.4 \pm 0.9\text{ lb-in}$).
3. Install the PE ground and EMC ground straps to the lugs provided. Tighten to 5.1 Nm (45 lb-in).

CPC-DX Calibration

Refer to Woodward manual **26615** for detailed instructions on calibrating the CPC-II's.

To minimize the system disturbance during transfer of control between the two CPC-II's, it is important that both the pressure on the hydraulic drain and dynamic adjustments of both CPC-II's be the same.

Once calibration is complete, several transfers should be completed between both CPC-II's with a common demand signal of 12 mA to ensure that the output of both CPC-II's responds correctly to a switching demand but also damps quickly and is stable after transfer.

To aid with calibration, pressure gages are provided on the skid assembly (see Figure 1-2). These gages indicate which unit is in control. A pressure indication of 0.8 bar / 11.6 psi (default value) lower than the master pressure indicates that the slave unit is successfully operating in back-up mode.

IMPORTANT

During calibration use pressure gauges to confirm that the control pressure is equal for both CPC-II's for the same setpoint level when Unit In Control mode is activated.

Chapter 4. Operation

Perform the following procedure steps in the order as stated while commissioning and tuning the CPC-DX skid:

! WARNING

Only trained personnel should be allowed to work on this device during operation.
Incorrect action could cause release of pressurized oil which could present a risk of burn or fire hazard.
Incorrect operation or improper tuning could cause erratic operation when the system is operated automatically by the turbine control system. Proper tuning is essential before transferring to automatic operation.

! WARNING

Automatic process control should not be activated until the commissioning procedure and device dynamic tuning for both units is complete.

! WARNING

CPC-II will be switch to the shutdown condition when control signal is set or drop below 2 mA.

IMPORTANT

Due to the wide variety of different relay valves and actuators combination, it is not possible for a single set of parameters to be optimum for all applications, therefore it is recommended that the CPC-II converter be tuned and verified for proper operation on each type of configuration to which it is applied.

IMPORTANT

A record of all parameters should be maintained by the user for future reference to assist in determining the optimum values for similar systems.

WARNING
Sudden Movement

Stay clear of the actuator output shaft and all equipment that may be actuated by the Discrete or Analog Output, as sudden movement can occur at any time. Failure to comply with this recommendation can cause personal injury and/or property damage.

All outputs are capable of changing states in Run Mode. Any outputs connected to the CPC-DX can suddenly move with this change of state. Use caution when using this tool

Clearing diagnostics may change the state of device outputs. Stay clear of the actuator output shaft and all attachments. Failure to comply with this recommendation can cause personal injury and/or property damage.

The CPC-DX can be controlled remotely, make sure area is clear before connecting tool.

Entering manual modes and/or changing modes may change the state of device outputs. Stay clear of the actuator output shaft and all attachments. Failure to comply with this recommendation can cause personal injury and/or property damage.

An improperly calibrated control could cause an overspeed or other damage to the prime mover. To prevent possible serious injury from an overspeeding prime mover, read and follow this entire procedure before starting the prime mover.

- ❑ Shut down and tag out the turbine or controlled process in accordance with site operating procedures.
- ❑ Attach the CPC-DX skid to a solid mounting location using six (6) M14x2 Class 8.8 minimum screws (not delivered with unit) and washers (delivered with unit) in accordance with Figure 1-5. Typical tightening torque 67 ± 7 Nm (50 ± 5 lb-ft) assuming mounting base material Yield Strength minimum at level 662 MPa / 96 ksi.
- ❑ Connect all hydraulic lines and verify the flow direction of all the hydraulic connections attached to the CPC-DX skid manifold.

Make all electrical and signal connections in accordance with Figure 1-6, Figure 1-7, Figure 1-8 and Chapter 3.

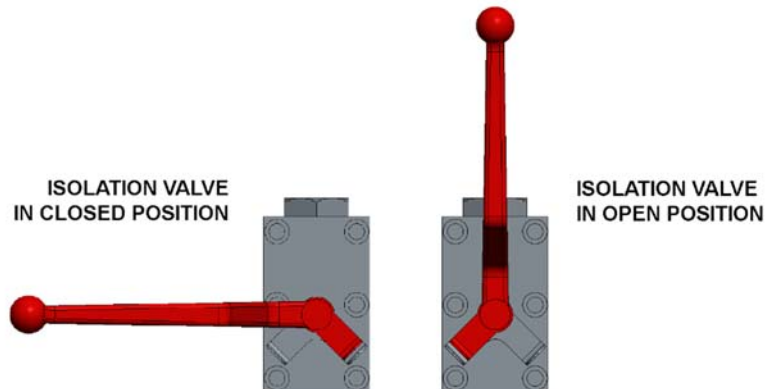

Figure 4-1. Isolation Valve OPEN / CLOSED Lever Position

WARNING

Open and close all valves slowly. This will help prevent creating any hydraulic disturbances in the system.

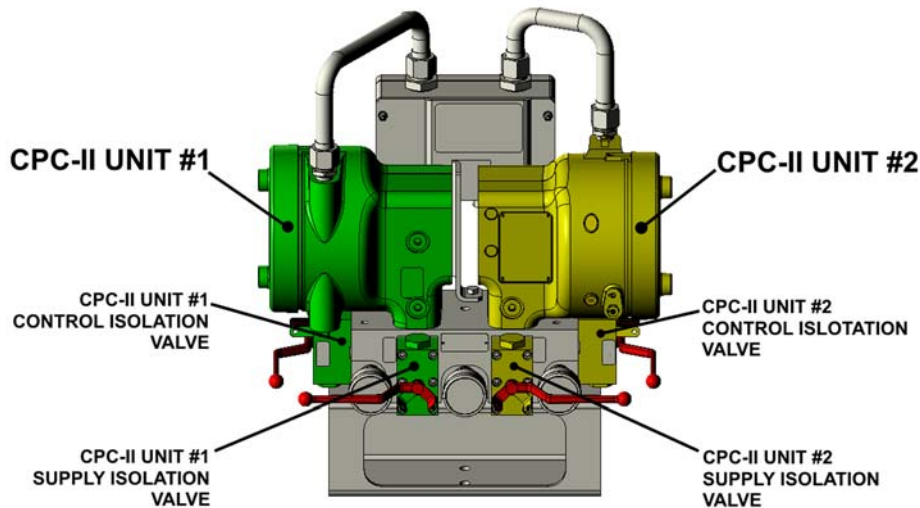

Figure 4-2. CPC-DX Unit with All Isolation Valves in **CLOSED** Position

- Close the supply isolation valve and control isolation valve to both CPC-II units and drain isolation valve if necessary (not provided).

WARNING

Make sure that proper supply, control, and return (if necessary) isolation valves are closed, locked out and tagged and turbine or control process is in a shutdown condition during the CPC-II installation or CPC-DX skid maintenance.

WARNING

Make sure that CPC-DX skid drain port is opened before supply valve opening.

WARNING

Make sure that turbine or operated process is in a shutdown condition when activating CPC-II converter Manual Mode.

- Slowly increase supply pressure to CPC-DX unit.
- Inspect all hydraulic connections to ensure there are no leaks.
- Switch on power supply 24 VDC to the one CPC-II unit.

NOTICE

Recommend the CPCs be powered from separate power sources. A switch is recommended at the power source to facilitate servicing the unit.

- Switch the Master/Slave relay to switch Master Designation to the #1 unit (see Chapter 3 and Figure 3-3 for electrical connections).
- Use the PC Service Tool, or adjust the setpoint signal (4...20 mA input) to the required minimum and maximum control pressure.

- Use the PC Service Tool to configure the discrete inputs and outputs of the converter (For more information see CPC-II manual **26615** Chapter 4).
- Slowly open the **Drain** isolation valve on one side of the CPC-DX skid (CPC-II unit #1).
- Slowly open the **Supply** isolation valve on one side of the CPC-DX skid (first CPC-II unit #1).
- Slowly open the **Control** isolation valve on one side of the CPC-DX skid (first CPC-II unit #1).

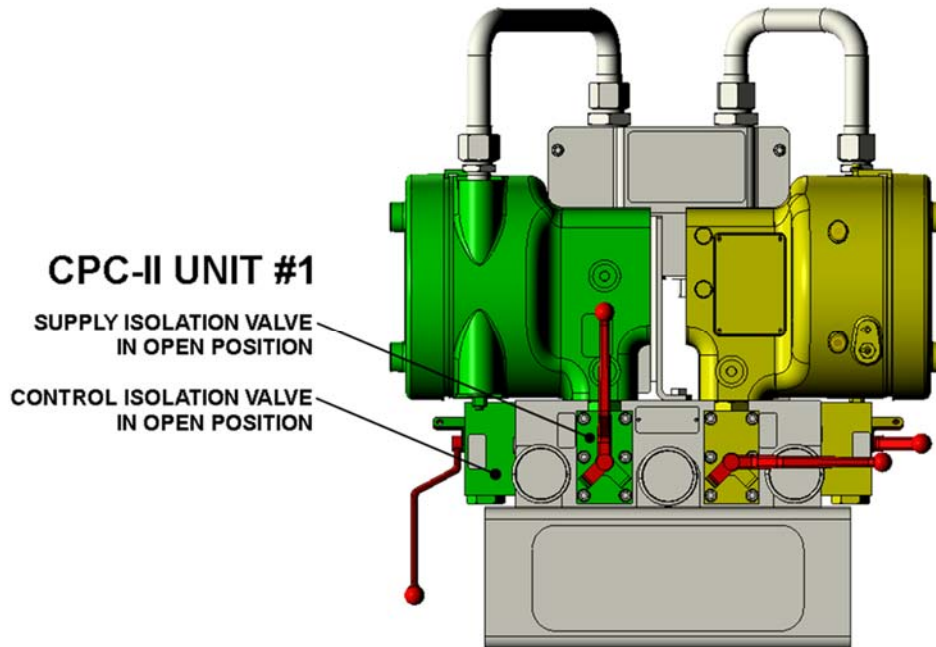

Figure 4-3. CPC-DX Unit CPC-II Unit #1 with Supply and Control Isolation Valves in Open Position

Use the PC Service Tool to adjust the CPC Unit #1 dynamic parameters for optimal dynamic response as follows.

- Adjust the supply pressure variable to match the system pressure provided to the CPC-DX unit.
- Adjust the primary gain at the midpoint of the control range for rapid control response with minimal overshoot. Some overshoot is permissible as it is necessary for displacement of the servo.
- Check performance by switching between the midpoint and the high point of the control range. If the performance is not sufficiently stable, reduce the primary gain for minimal overshoot, minimal ringing, and stable control.
- Check performance by switching between the midpoint and the low point of the control range. Typically the performance will be more stable at this operating point if tuned properly for high pressure and mid pressure performance. Repeat the tuning at high low and mid pressure levels as necessary until the control is optimized over the entire range.
- When tuning is satisfactory, upload the user parameters into a settings file directory on the computer hard drive (please refer Woodward Manual **26615** for instructions).
- Download the saved parameter file (from CPC unit #1) into CPC unit #2.
- Switch on the power supply 24 VDC to the CPC-II Unit #2.
- Switch the Master/Slave relay to switch the Master Designation to CPC Unit #2. (See Chapter 3 and Figure 3-3 for electrical connections).
- Confirm in the service tool that the CPC Unit #2 is in control.
- Slowly open the **Drain** isolation valve on second side of the CPC-DX skid (CPC unit #2).
- Slowly open the **Supply** isolation valve to CPC Unit #2.
- Slowly open the **Control** isolation valve to CPC Unit #2.
- Inspect all hydraulic connections to ensure there are no leaks.

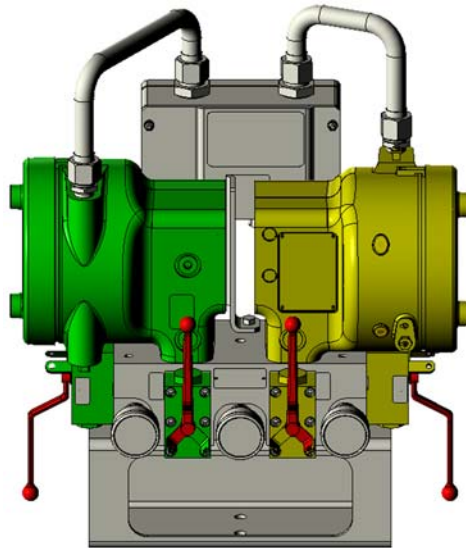

Figure 4-4. CPC-DX Unit With All Isolation Valves in **OPEN** Position

- Close the **Control** pressure isolation valve to the first CPC.

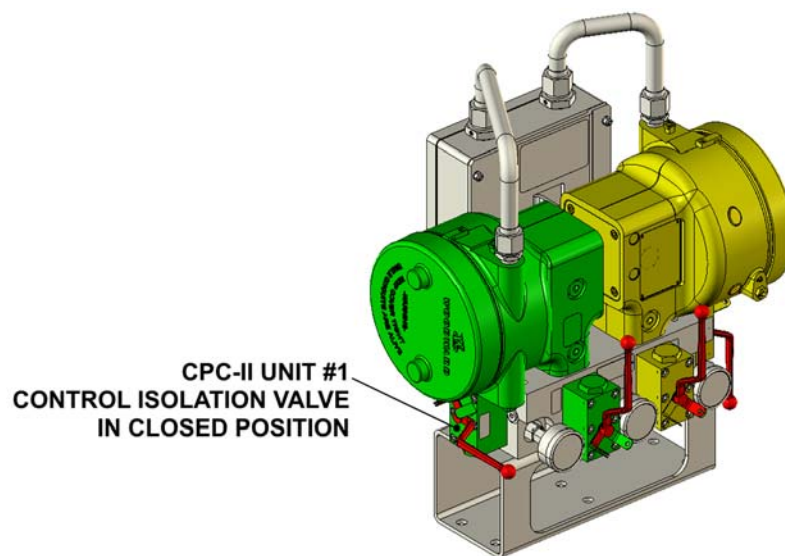

Figure 4-5. CPC-DX Skid with CPC-II Unit #1 Control Isolation Valve in **CLOSED** Position

- Use the PC Service Tool to confirm the 2nd CPC dynamic parameters for optimal dynamic response.
- Adjust the primary gain at the midpoint of the control range for rapid control response with minimal overshoot. Some overshoot is permissible as it is necessary for displacement of the servo
- Check performance by switching between the midpoint and the high point of the control range. If the performance is not sufficiently stable, reduce the primary gain for minimal overshoot, minimal ringing, and stable control.
- Check performance by switching between the midpoint and the low point of the control range. Typically, the performance will be more stable at this operating point if tuned properly for high pressure and mid pressure performance. Repeat the tuning at high low and mid pressure levels as necessary until the control is optimized over the entire range.
- Open both **Control** isolation valves to the converters
- Switch the Master/Slave relay to switch control between units (see Chapter 3 and Figure 3-3 for electrical connections).
- Perform several transfers between both CPCs with a demand signal of 12 mA to ensure that the CPCs switch correctly and that the output is stable after transfers.

- Repeat switching performance at high, mid and low demand signal levels.
- Power down the first CPC_II, verify if the second CPC-II takes control.
- Repower the first CPC-II, verify it resumes control at the correct offset level (factory default is 0.8 Bar)
- Power down the second CPC-II, confirm that the first unit takes control.
- Repower the second CPC-II, verify it resumes control at the correct offset level (factory default is 0.8 Bar)

During normal operation the master/slave" indication shows only which unit is designated to be in control based on connection status of the Discrete input #1.

To confirm which unit is actually in control of the CPC-DX skid output pressure the unit in control status should be verified by the status of discrete output 2, the status indication in the service tool, and the pressure indicated on the gages.

If a CPC-II should fail, it can be locked out of the system using the control isolation and supply isolation valve. To ensure there is no electrical transient created on the unit in control, it is mandatory to power down the failed converter, and open the switches on the status link within the terminal block before removal from the CPC-DX skid.

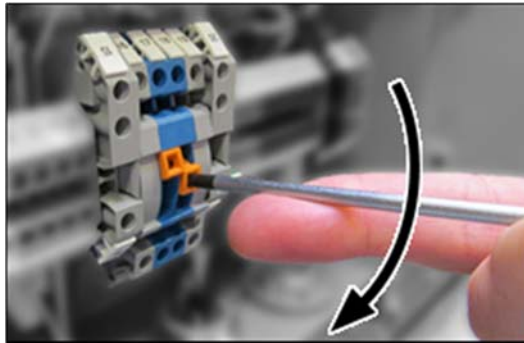

Figure 4-6. CPC-DX Status Link Disconnection Inside Main Terminal Box

For a full description of the CPC-II, see Woodward manual [26615](#).

! WARNING

For the failure CPC-II replacement procedure, see Woodward manual [26824](#).

! WARNING

When intending to service a faulted CPC-II converter, always use the following order to ensure there are no interactions with the operating converter.

- 1) Power down the failed unit.
- 2) Close and lock-out the control isolation valve
- 3) Close and lock-out the supply isolation valve
- 4) Close and lock-out the drain isolation valve if necessary (not provided with CPC-DX unit)
- 5) Ensure the work area around the skid is free from combustible medium before removing covers.
- 6) Disconnect the health status link switches

IMPORTANT

The CPC-DX skid includes provisions for paddle locks to securely lock out the supply and control isolation valves. Follow all plant designated lock-out /tag out procedures.

IMPORTANT

It is recommended that the control is switched periodically between CPC-II's to help flush sediment contamination from the CPC-DX skid. Additionally it is recommended that the discrete output that signals internal faults is connected to the turbine control system. This will ensure that both converters are functioning at the time of Master/Slave switchover.

CPC-DX performance

The CPC-DX skid characterizes very short transfer time and stable control pressure during unit to unit control switchover and in case of unit in control fault or shutdown. Special shuttle valve design provides "pressure bumpless" switchover between CPCs which minimize disturbance on servo valve or other control system. Additionally advanced shuttle valve design provides high dirt tolerance and leak tight construction.

Diagrams below show typical transfer performance for control pressure and for particular hydraulic flow.

Demand Signal 12 mA, Control pressure 3.0 bar / 43.5 psi, hydraulic flow on the control line approx. 3 l/min / 0.7 gpm (typical servo application).

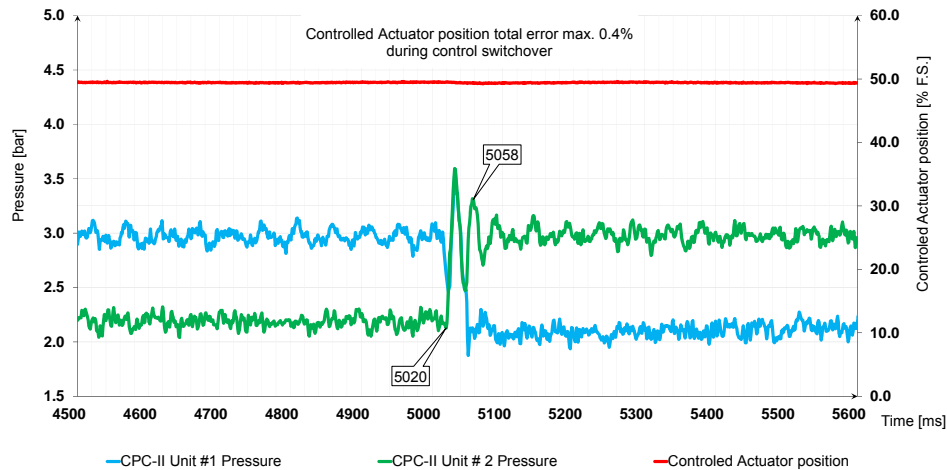

Figure 4-7. CPC-DX Unit to Unit Control Switchover – Switchover Action Typical Performance

Demand Signal 12 mA, Control pressure 3.5 bar, hydraulic flow on the control line 3 l/min (typical servo application).

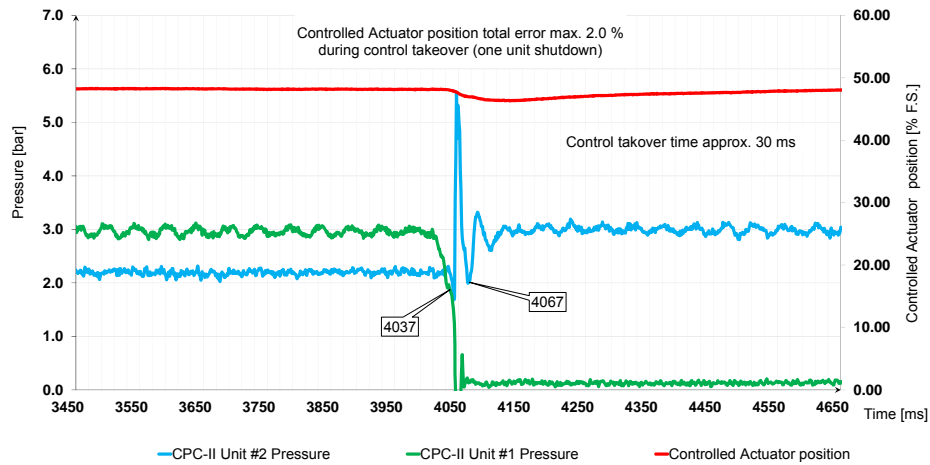

Figure 4-8. CPC-DX Unit Control Takeover (Second Unit Shutdown Simulation)

Noticeable control pressure oscillations on both above graphs are an effect of usage of the Dither function in CPC-II dynamic settings. See manual **26615** for more details regarding Dither functionality and settings.

CPC-DX Unit Tuning

To properly tune up CPC-DX unit, please follow the instructions below in the specific sequence as described.

1. Determine the appropriate pressure offset between CPC-II Unit #1 and CPC-II Unit #2.

The software within the CPC-II allows the user to adjust the pressure offset between CPC-II Unit #1 and CPC-II Unit #2. All factory testing has been performed with an offset value of 0.8 bar. This is the recommended default for proper and stable internal shuttle valve operation.

IMPORTANT

The default offset value of 0.8 bar is sufficient to ensure CPC-DX operation with flow to the control line up to 23 lpm (6 gpm). If the application requires higher flow rates to the control line, the offset pressure between units will need to be increased.

If the application requires higher flow rates than the factory default offset will allow, refer to the graph shown in Figure 4-9, determine the minimum pressure offset value required for stable operation for the required flow through the CPC-DX skid control line at the required flow rate.

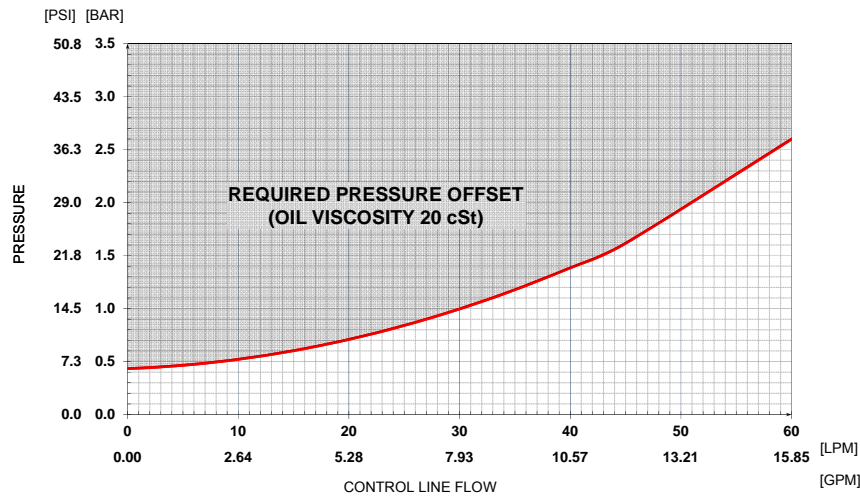

Figure 4-9. CPC-DX Skid Pressure between CPC-II Units (Pressure Offset) at 20 cSt Oil Viscosity

The offset can be adjusted via the PC service tool by adjusting the value displayed as “In Slave Mode Setpoint is Decreased to.” See manual 26615, Section - Configure Redundancy.

Note: The setting of the pressure offset parameter has a direct impact on performance – a higher offset will generally result in a larger transient during switchover between CPCs.

IMPORTANT

The Pressure offset parameter must be set on this same level for CPC-II Unit #1 and CPC-II Unit #2.

Dynamics Tuning:

2. Perform demand steps of +/- 25% at the demand signal midpoint and observe the response of the controlled actuator. (i.e. step the setpoint from 8-16-8 mA when using a 4-20 mA control signal range; 12 mA midpoint).

IMPORTANT

The unit should be tuned for the best performance as observed at the actuator. The pressure response is not a direct indicator of actuator response. See the following graphic representations.

- a. If the default parameters provide sluggish or underdamped performance or if the unit CPC-II indicates any performance faults or alarms, tune the parameters as follows:
 - i. Adjust the Primary Gain to achieve satisfactory and stable unit operation.

Tuning runs showing the effect of example parameter values are shown below.

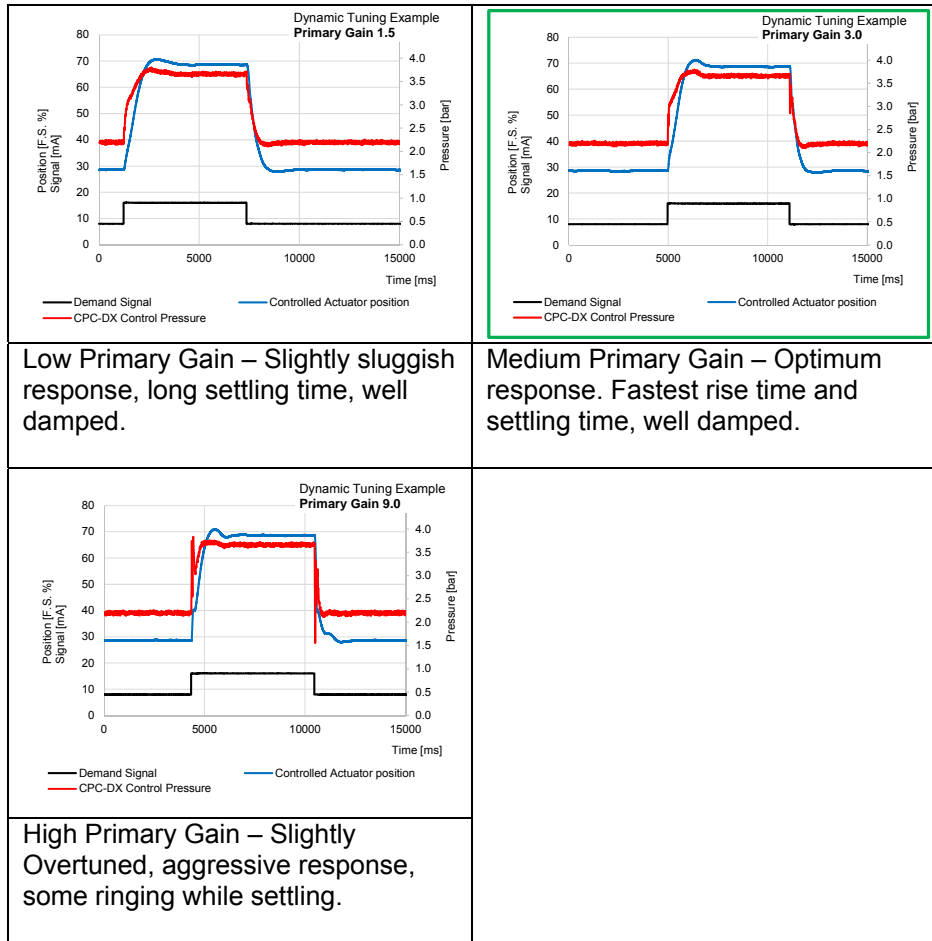

Figure 4-10. Tuning Runs Showing the Effect of Adjusted Primary Gain Example Parameter Values

- ii. Adjust Proportional Trim parameter to optimize controlled unit response.

Tuning runs showing the effect of example parameter values are shown below.

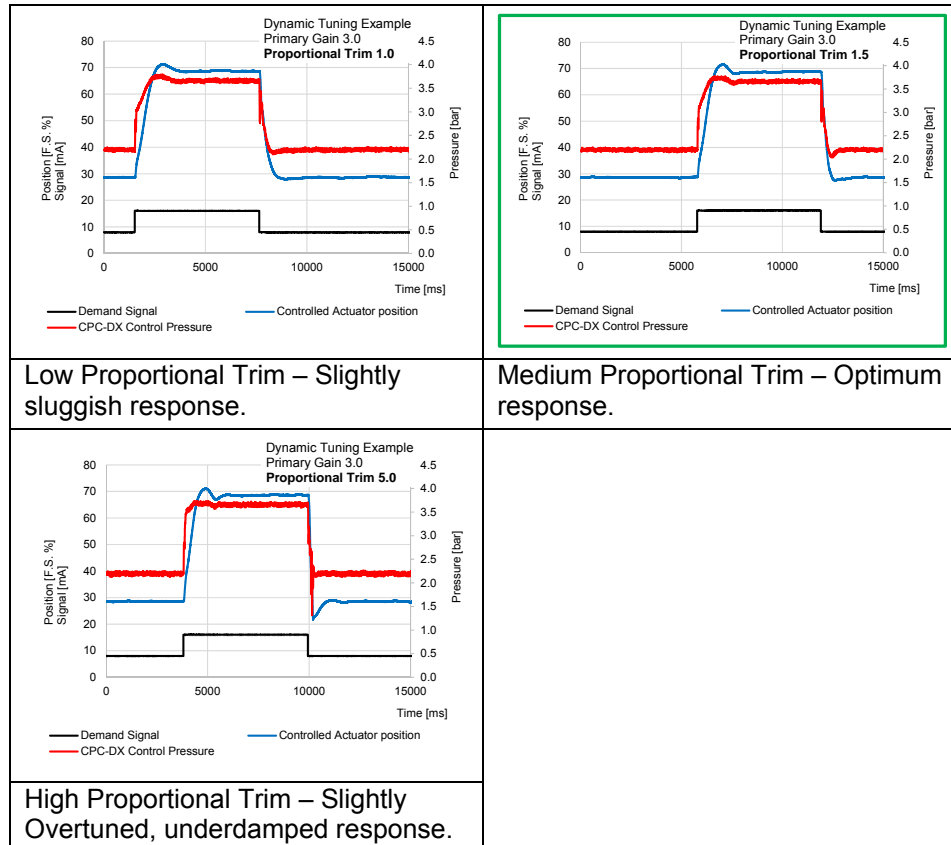

Figure 4-11. Tuning Runs Showing the Effect of Adjusted Proportional Trim Example Parameter Values

- iii. If necessary, adjust the Integral Trim parameter to optimize controlled unit response (in most cases, the best performance is achieved when both parameters have equal value)

Tuning runs showing the effect of example parameter values are shown below.

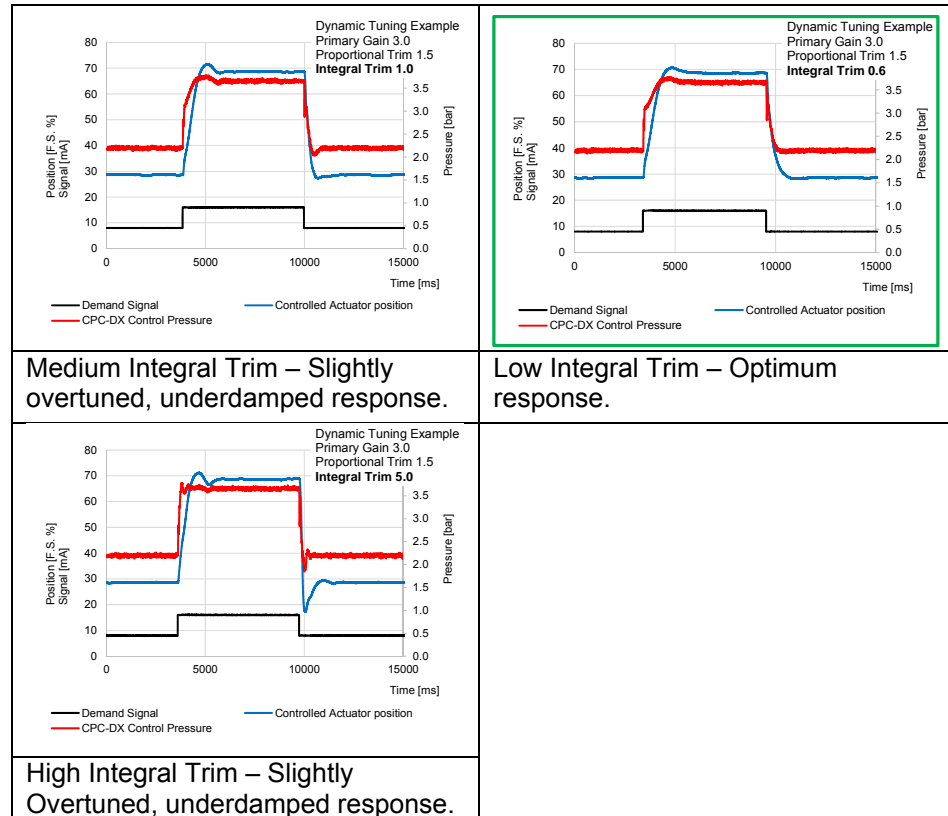

Figure 4-12. Tuning Runs Showing the Effect of Adjusted Integral Trim Example Parameter Values

- iv. Once the performance has been tuned to a satisfactory level, go to the next tuning step. If the performance is not satisfactory at various control pressures, adjust the tuning parameters starting with the primary gain and completing with the integral trim as described in sections 2.1 to 2.1.4.
3. Perform a demand step of 0-100-0% of the control range. Observe the controlled actuator response.
 - a. If the factory default parameters provide unsatisfactory performance tune the parameters as described below:
 - i. Proportional Trim (at Valve Limits or Not In Control Mode).

Tuning runs showing the effect of example parameter values are shown below.

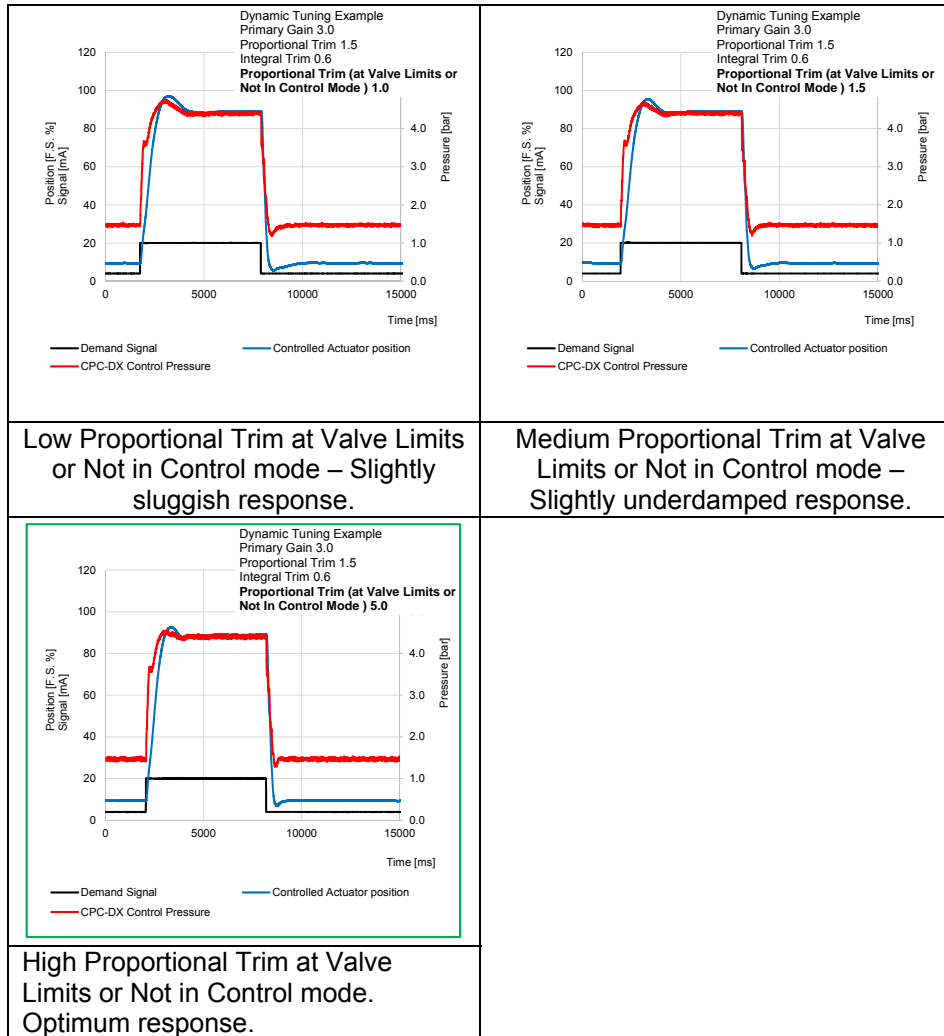

Figure 4-13. Tuning Runs Showing the Effect of Proportional Trim Example Parameter Values

If the performance is satisfactory, proceed to the next tuning step, if not; make another tuning iteration noting the impact on behavior as described above.

4. Perform a controlled Unit-Unit control switchover and observe the controlled actuator response.

Note: Perform the Unit-Unit control switchover tuning process at a demand level corresponding to a typical demand level expected for the majority of field operation. If the operating range will vary significantly over time, perform the tuning process at 50% demand signal (e.g. 12 mA when using a 4-20 mA control signal).

 - a. Adjust the Load Leakage Compensation parameter to achieve satisfactory and stable unit operation.
 - i. The Load Leakage Compensation (LLC) parameter is intended to improve the redundant switchover when there is a significant leakage (flow) on control line and is activated during Unit to Unit control switchover only.
 - ii. LLC value is specific for each CPC-II unit - difference helps to compensate small unit to unit variation (i.e. internal leakage variation due to components tolerance variation).

Tuning runs showing the effect of example parameter values are shown below.

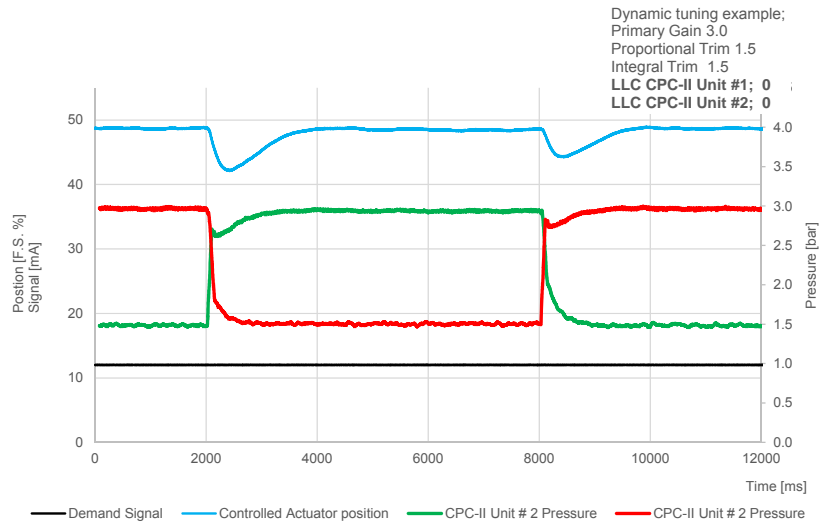

Figure 4-14. Low LLC Parameter – Sluggish Response, Visible Controlled Unit Position Variation, and Unit-To-Unit Performance Difference

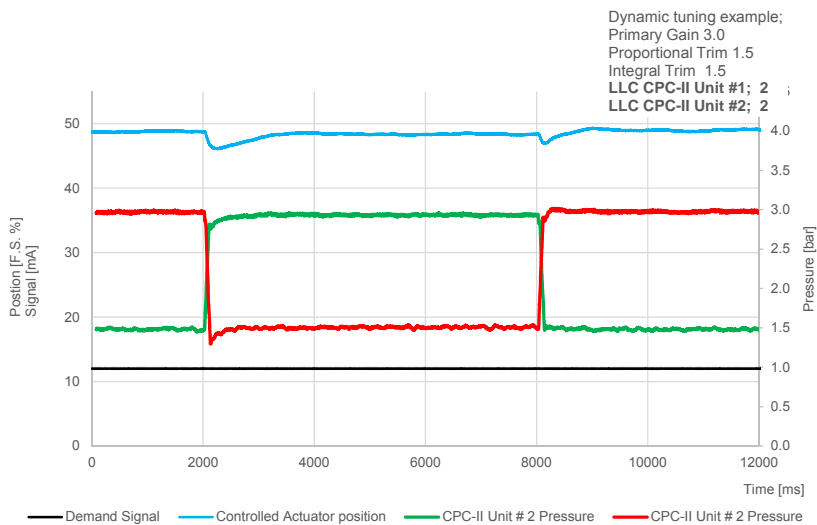

Figure 4-15. Low LLC Parameter – Slightly Sluggish Response, Still Visible Controlled Unit Position Variation, and Unit To Unit Performance Difference

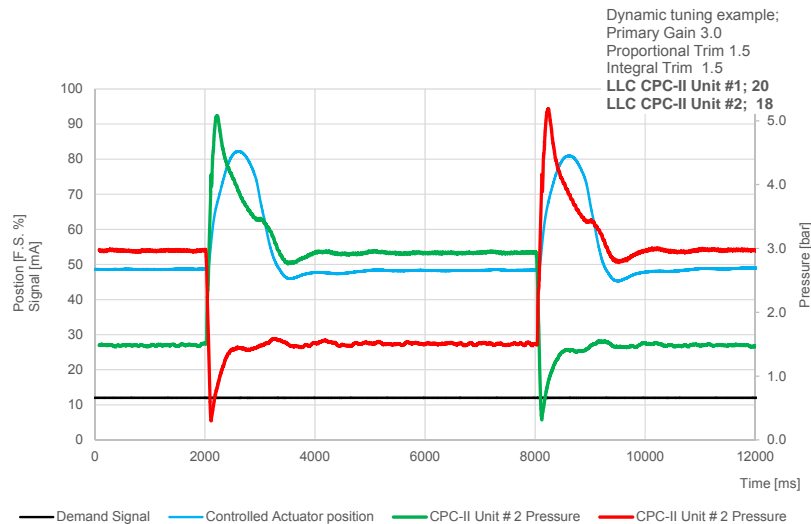

Figure 4-16. High LLC Parameter – Visible Controlled Unit Position Overshoot, Acceptable Unit-To-Unit Performance Difference

Save settings.

5. Perform a final performance verification run with saved parameters:
6. Perform demand step 50% of control range.
 - a. Perform demand step 0-100% of control range.
 - b. Perform controlled Unit-Unit control switchover.
 - c. Record the results in a report or document for future reference.

Online Change-Out of a Pressure Gauge

Pressure gauges are connected to the measuring points inserted directly in the manifold. Both ends of the measuring points are provided with threaded isolation couplings which are mated between the gauge and the manifold connections.

1. Exchange procedure of a defective pressure gauge during operation:
 - Use flat wrench SW 22 and then use hand to unscrew (in counterclockwise direction) adapter with pressure gauge from pressure test port (see Figure 4-10.)

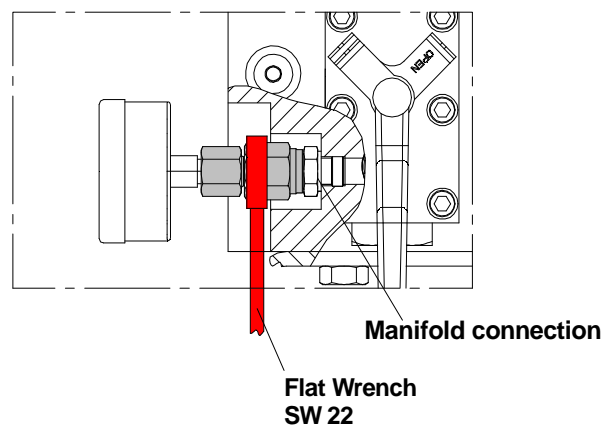

Figure 4-17. Pressure Gauge Untightening from Manifold

WARNING

Do not unscrew only pressure gauge without adapter (with flat wrench SW 11 mm or SW 14 mm) when system is pressurized - pressurized oil may leak and contact hot surfaces. There is a risk of fire or body injury!

WARNING

In case of faulty actions pressurized oil may leak and contact hot surfaces. There is a risk of fire or body injury!

- To remove the adapter with the pressure gauge, use a flat wrench size SW 19 mm to hold the manifold adapter in position. Using a flat wrench size SW 11 mm or SW 14 mm to unscrew pressure gauge (in counter clockwise direction). See Figure 4-18.

Flat Wrench SW 11 or SW 14
depends on gauge
mounting style

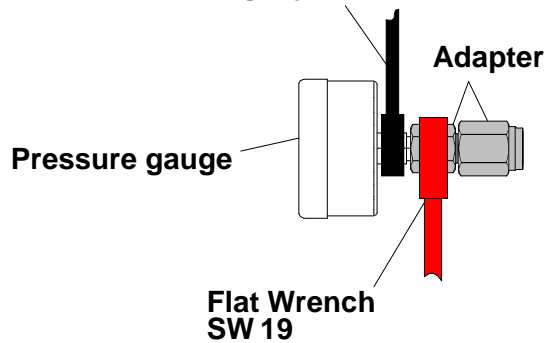

Figure 4-18. Pressure Gauge Untightening From Adapter

- Attach the pressure gauge to the adapter and torque to 38-43 Nm (28-32 FT LB).
- Hand tighten the adapter to the test port and then tighten an additional 1/4 turn using a flat wrench size SW 22 mm.

IMPORTANT

Be sure that pressure gauge is appropriate for the specific model of the SKID CPC-II. Different gauges are available for the 10 and 25 bar units.

Chapter 5. Repair and Troubleshooting

General

Preventative maintenance is an important part of performance, reliability, and extending the life of the CPC-DX skid. Woodward recommends the following service schedule:

- During normally scheduled major inspection and outages, the complete CPC-DX skid be overhauled and retested to factory level quality at a Woodward authorized service center
- Between major inspections based on your sites normal maintenance cycles or seasonal outages, the individual CPC converters be sent to a Woodward authorized service center for clean and test

Replacement kits for sections of the CPC-DX skid are available from a Woodward authorized distributor for your local stock that enable you to have the security and immediate response to a service need.

Use of a cable gland or stopping plug that does not meet the hazardous area certification requirements, thread form, or thread size will invalidate the suitability for hazardous locations.

Do not remove or alter the nameplate as it bears important information which may be necessary to service or repair the unit.

Table 5-1. List of available Replacement Kits

#	P/N to order	Description
1	8923-1996	KIT-CPC REPLACEMENT, 10 BAR, ZONE 2, FOR CPC-DX SKID
2	8923-1997	KIT-CPC REPLACEMENT, 25 BAR, ZONE 2, FOR CPC-DX SKID
3	8923-2236	KIT-REPLACEMENT ISOLATION VALVE: CPC 2 CONTROL OR CPC 2 SUPPLY, FOR CPC-DX SKID
4	8923-2242	KIT-REPLACEMENT ISOLATION VALVE, LEFT HAND: CPC 1 CONTROL OR CPC 1 SUPPLY, FOR CPC-DX SKID
5	8923-2237	KIT-PRESSURE GAUGE, 10 BAR, FOR CPC-DX SKID
6	8923-2238	KIT-PRESSURE GAUGE, 25 BAR, FOR CPC-DX SKID
7	8923-2239	KIT-SHUTTLE VALVE, FOR CPC-DX SKID

Troubleshooting

General

The following troubleshooting guide will help you isolate trouble with the control circuit board, actuator, wiring, and system problems. Recommend troubleshooting beyond this level **ONLY** when a complete facility for control testing is available.

The wrong voltage can damage the control. When replacing a control, check the power source and wiring connections for the correct voltage.

Troubleshooting Procedure

This table is a general guide for isolating system problems. In general, most problems are a result of incorrect wiring or installation practices. Make sure that the system wiring, input/output connections, controls and contacts are correct and in good working order. Complete the checks in order. Each check assumes that the preceding checks have been completed and any problems have been corrected.

 WARNING	Be prepared to make an emergency shutdown when starting the engine, turbine, or other type of prime mover, to protect against runaway or overspeed with possible personal injury, loss of life, or property damage.
--	--

For CPC-II troubleshooting, see manual **26615**.

Table 5-2. Troubleshooting

Symptom	Cause	Recommended Action
No pressure at the control port	Faulty power, check for green LED.	Check power connections, 24 V (dc) pins 2, 33 (+) and 3, 32(-).
	Error condition, check red LED (alarm or shutdown; discrete output is active).	If on: Check actuator wire connection.
	No hydraulic supply.	Check hydraulic supply pressure and ensure all lines are connected to the appropriate ports.
	Power supply too weak.	Monitor the supply voltage while making a large step. The voltage should not dip or rise significantly. See recommended power requirements in the specification section..
	Power supply is limiting current.	Change limit level to maximum (≥ 5 A).
	Bad power supply.	Use Woodward recommended power supply.
	Electronics fault in CPC-II.	Check for electronics fault using PC service tool.
Pressure control fluctuation	No pressure indication on control gauge	Open supply and control valve
	Fluid lines incorrectly installed.	Check fluid connections.
	No redundancy linkage	Check wires.
	Contamination within control.	Check the fluid for excessive contamination. Replace or add a system filter ahead of the CPC-DX unit supply. Contact Woodward service.
	To high oil flow	Check the oil installation and servo valve for leakage
No transfer valve switching	Contact Woodward service.	

Symptom	Cause	Recommended Action
Slow dynamics	Dynamic adjustments not optimal.	Adjust primary gain and/or proportional trim or integral trim and/or load leakage compensation parameter.
	Cold oil (viscosity too high).	Wait until normal temperature is reached
	Connections line tubes too small or too long.	Use bigger and/or shorter tubes.
	Insufficient pump capacity	Monitor the supply pressure while performing a maximum pressure step, the supply pressure should not drop significantly.
High-frequency oscillation	Control settings are attempting to regulate the Servo outside its travel range (excessive hydraulic stiffness).	Modify input scaling and/or gain switching values. Reduce the At Valve Limit proportional trim settings if attempting to control the unit below the opening travel.
	Dynamic adjustments are not optimal	Reduce gain settings.
	High friction in servo.	Clean or change servo piston.
	High CPC-II internal friction.	Check the fluid for excessive contamination. Replace or add a system filter ahead of the CPC-II supply. Increase the frequency of the Silt Buster impulse. Contact Woodward service.
Low-frequency oscillation	Dynamic adjustments are not optimal.	Adjust Integral Trim settings.
Discrete outputs not working	Incorrect wiring.	Correct wiring.
(4 to 20) mA output not working	Incorrect wiring.	Correct wiring. Verify analog output settings match control.
Intermittent behavior	Intermittent wiring.	Replace faulty wire(s).
	Damaged insulation.	Replace faulty wire(s).
	Bad contact at connectors.	Re-install all wires.
	Too high ambient or oil temperature.	Lower temperature. See specification.
Internal CPC-II oil leakage	Pressure sensor is loose, O-ring is damaged.	Re-torque the pressure sensor. Replace O-ring.
	Excessive wear or damage of valve shaft seals.	Replace CPC II and Adjust Control System: - Check for control signal instability. If control signal is highly active reduce dynamic settings at main control. Check wiring for proper shielding or ground loops. Correct these issues until the demand signal is stable. - Check for excessive drain pressure. - Check for CPC stability with stable demand signal. If unstable, adjust dynamic settings (see Chapter 6). - Reduce or eliminate dither setting in the CPC II and/or at the main control.

Symptom	Cause	Recommended Action
Large servo-position hysteresis	Abnormal high friction in servo.	Adjust control dither in CPC-II Clean or change servo piston.
	Excessive input control noise.	Reduce or eliminate dither at turbine control. Check wiring for ground loops. Check for instability, reduce dynamic settings at CPC-II or main control.
Non-zero pressure when shut down	Drain pressure is too high.	Reduce Drain pressure.
No switching between units	No health signal communication between units	Check Wiring between units.
	Excessive control line flow rate.	Check the oil installation and servo valve for leakage
Non-Symmetric Switching performance between units on the same skid.	Contamination	Check the fluid for excessive contamination. Replace or add a system filter ahead of the CPC-DX supply. Contact Woodward service.
	Incorrect settings/calibration	Using PC Service Tool perform the recommended tuning procedure. Ensure both units are set with the same dynamic settings.
CPC-DX shutdown during demand signal change	Oil Viscosity is to high	Increase pressure offset between CPC-II units.
Or Instable control signal during operation (pressure)	Flow to the control line is to High	

Chapter 6.

Product Support and Service Options

Product Support Options

If you are experiencing problems with the installation, or unsatisfactory performance of a Woodward product, the following options are available:

- Consult the troubleshooting guide in the manual.
- Contact the manufacturer or packager of your system.
- Contact the Woodward Full Service Distributor serving your area.
- Contact Woodward technical assistance (see “How to Contact Woodward” later in this chapter) and discuss your problem. In many cases, your problem can be resolved over the phone. If not, you can select which course of action to pursue based on the available services listed in this chapter.

OEM or Packager Support: Many Woodward controls and control devices are installed into the equipment system and programmed by an Original Equipment Manufacturer (OEM) or Equipment Packager at their factory. In some cases, the programming is password-protected by the OEM or packager, and they are the best source for product service and support. Warranty service for Woodward products shipped with an equipment system should also be handled through the OEM or Packager. Please review your equipment system documentation for details.

Woodward Business Partner Support: Woodward works with and supports a global network of independent business partners whose mission is to serve the users of Woodward controls, as described here:

- A **Full Service Distributor** has the primary responsibility for sales, service, system integration solutions, technical desk support, and aftermarket marketing of standard Woodward products within a specific geographic area and market segment.
- An **Authorized Independent Service Facility (AISF)** provides authorized service that includes repairs, repair parts, and warranty service on Woodward's behalf. Service (not new unit sales) is an AISF's primary mission.
- A **Recognized Turbine Retrofitter (RTR)** is an independent company that does both steam and gas turbine control retrofits and upgrades globally, and can provide the full line of Woodward systems and components for the retrofits and overhauls, long term service contracts, emergency repairs, etc.

A current list of Woodward Business Partners is available at www.woodward.com/directory.

Product Service Options

The following factory options for servicing Woodward products are available through your local Full-Service Distributor or the OEM or Packager of the equipment system, based on the standard Woodward Product and Service Warranty (5-01-1205) that is in effect at the time the product is originally shipped from Woodward or a service is performed:

- Replacement/Exchange (24-hour service)
- Flat Rate Repair
- Flat Rate Remanufacture

Replacement/Exchange: Replacement/Exchange is a premium program designed for the user who is in need of immediate service. It allows you to request and receive a like-new replacement unit in minimum time (usually within 24 hours of the request), providing a suitable unit is available at the time of the request, thereby minimizing costly downtime. This is a flat-rate program and includes the full standard Woodward product warranty (Woodward Product and Service Warranty 5-01-1205).

This option allows you to call your Full-Service Distributor in the event of an unexpected outage, or in advance of a scheduled outage, to request a replacement control unit. If the unit is available at the time of the call, it can usually be shipped out within 24 hours. You replace your field control unit with the like-new replacement and return the field unit to the Full-Service Distributor.

Charges for the Replacement/Exchange service are based on a flat rate plus shipping expenses. You are invoiced the flat rate replacement/exchange charge plus a core charge at the time the replacement unit is shipped. If the core (field unit) is returned within 60 days, a credit for the core charge will be issued.

Flat Rate Repair: Flat Rate Repair is available for the majority of standard products in the field. This program offers you repair service for your products with the advantage of knowing in advance what the cost will be. All repair work carries the standard Woodward service warranty (Woodward Product and Service Warranty 5-01-1205) on replaced parts and labor.

Flat Rate Remanufacture: Flat Rate Remanufacture is very similar to the Flat Rate Repair option with the exception that the unit will be returned to you in "like-new" condition and carry with it the full standard Woodward product warranty (Woodward Product and Service Warranty 5-01-1205). This option is applicable to mechanical products only.

Returning Equipment for Repair

If a control (or any part of an electronic control) is to be returned for repair, please contact your Full-Service Distributor in advance to obtain Return Authorization and shipping instructions.

When shipping the item(s), attach a tag with the following information:

- Return authorization number
- Name and location where the control is installed
- Name and phone number of contact person
- Complete Woodward part number(s) and serial number(s)
- Description of the problem
- Instructions describing the desired type of repair

Packing a Control

Use the following materials when returning a complete control:

- Protective caps on any connectors
- Antistatic protective bags on all electronic modules
- Packing materials that will not damage the surface of the unit
- At least 100 mm (4 inches) of tightly packed, industry-approved packing material
- A packing carton with double walls
- A strong tape around the outside of the carton for increased strength

NOTICE

To prevent damage to electronic components caused by improper handling, read and observe the precautions in Woodward manual 82715, *Guide for Handling and Protection of Electronic Controls, Printed Circuit Boards, and Modules*.

Replacement Parts

When ordering replacement parts for controls, include the following information:

- The part number(s) (XXXX-XXXX) that is on the enclosure nameplate
- The unit serial number, which is also on the nameplate

Engineering Services

Woodward offers various Engineering Services for our products. For these services, you can contact us by telephone, by email, or through the Woodward website.

- Technical Support
- Product Training
- Field Service

Technical Support is available from your equipment system supplier, your local Full-Service Distributor, or from many of Woodward's worldwide locations, depending upon the product and application. This service can assist you with technical questions or problem solving during the normal business hours of the Woodward location you contact. Emergency assistance is also available during non-business hours by phoning Woodward and stating the urgency of your problem.

Product Training is available as standard classes at many of our worldwide locations. We also offer customized classes, which can be tailored to your needs and can be held at one of our locations or at your site. This training, conducted by experienced personnel, will assure that you will be able to maintain system reliability and availability.

Field Service engineering on-site support is available, depending on the product and location, from many of our worldwide locations or from one of our Full-Service Distributors. The field engineers are experienced both on Woodward products as well as on much of the non-Woodward equipment with which our products interface.

For information on these services, please contact us via telephone, email us, or use our website: www.woodward.com.

Contacting Woodward's Support Organization

For the name of your nearest Woodward Full-Service Distributor or service facility, please consult our worldwide directory at www.woodward.com/directory, which also contains the most current product support and contact information.

You can also contact the Woodward Customer Service Department at one of the following Woodward facilities to obtain the address and phone number of the nearest facility at which you can obtain information and service.

Products Used in Electrical Power Systems	
Facility	Phone Number
Brazil	+55 (19) 3708 4800
China	+86 (512) 6762 6727
Germany:	
Kempen	+49 (0) 21 52 14 51
Stuttgart	+49 (711) 78954-510
India	+91 (124) 4399500
Japan	+81 (43) 213-2191
Korea	+82 (51) 636-7080
Poland	+48 12 295 13 00
United States	+1 (970) 482-5811

Products Used in Engine Systems	
Facility	Phone Number
Brazil	+55 (19) 3708 4800
China	+86 (512) 6762 6727
Germany	+49 (711) 78954-510
India	+91 (124) 4399500
Japan	+81 (43) 213-2191
Korea	+82 (51) 636-7080
The Netherlands	+31 (23) 5661111
United States	+1 (970) 482-5811

Products Used in Industrial Turbomachinery Systems	
Facility	Phone Number
Brazil	+55 (19) 3708 4800
China	+86 (512) 6762 6727
India	+91 (124) 4399500
Japan	+81 (43) 213-2191
Korea	+82 (51) 636-7080
The Netherlands	+31 (23) 5661111
Poland	+48 12 295 13 00
United States	+1 (970) 482-5811

Technical Assistance

If you need to contact technical assistance, you will need to provide the following information. Please write it down here before contacting the Engine OEM, the Packager, a Woodward Business Partner, or the Woodward factory:

General

Your Name _____

Site Location _____

Phone Number _____

Fax Number _____

Prime Mover Information

Manufacturer _____

Turbine Model Number _____

Type of Fuel (gas, steam, etc.) _____

Power Output Rating _____

Application (power generation, marine,
etc.) _____

Control/Governor Information

Control/Governor #1

Woodward Part Number & Rev. Letter _____

Control Description or Governor Type _____

Serial Number _____

Control/Governor #2

Woodward Part Number & Rev. Letter _____

Control Description or Governor Type _____

Serial Number _____

Control/Governor #3

Woodward Part Number & Rev. Letter _____

Control Description or Governor Type _____

Serial Number _____

Symptoms

Description _____

If you have an electronic or programmable control, please have the adjustment setting positions or the menu settings written down and with you at the time of the call.

Chapter 7.

Asset Management and Refurbishment Scheduling Period

This product is designed for continuous operation in a typical industrial environment and includes no components that require periodic service. However, to take advantage of related product software and hardware improvements, we recommend that your product be sent back to Woodward or to a Woodward authorized service facility after every five to ten years of continuous service for inspection and component upgrades. Please refer to the above service programs when returning products.

Chapter 8. Long-Term Storage Requirements

Units that will not be put into service within twelve months should be packaged for long-term storage as described in Woodward manual 25075.

Revision History

Changes in Revision B—

- Updated Declaration of Conformity and Declaration of Incorporation statements
- Updated Certifications in Regulatory and Compliance Section

Changes in Revision A—

- Updated Declaration of Conformity and Declaration of Incorporation statements

Declarations

EU DECLARATION OF CONFORMITY

EU DoC No.: 00383-04-EU-02-103
Manufacturer's Name: WOODWARD INC.
Manufacturer's Contact Address: 1041 Woodward Way
 Fort Collins, CO 80524 USA
Model Name(s)/Number(s): SKID – REDUNDANT CPC-II
The object of the declaration described above is in conformity with the following relevant Union harmonization legislation: Directive 2014/34/EU on the harmonisation of the laws of the Member States relating to equipment and protective systems intended for use in potentially explosive atmospheres
 Directive 2014/30/EU of the European Parliament and of the Council of 26 February 2014 on the harmonization of the laws of the Member States relating to electromagnetic compatibility (EMC)
Markings in addition to CE marking:  Category 3 Group II G, Ex nA Gas Group IIC, T4 Gc IP66
Applicable Standards: EN61000-6-2, 2005: EMC Part 6-2: Generic Standards - Immunity for Industrial Environments
 EN61000-6-4, 2007/A1 :2011: EMC Part 6-4: Generic Standards - Emissions for Industrial Environments
 EN60079-0:2012/A11:2013: Explosive Atmospheres - Part 0: Equipment – General requirements
 EN60079-15: 2010: Explosive Atmospheres - Part 15: Equipment protection by type of protection "n"

This declaration of conformity is issued under the sole responsibility of the manufacturer
 We, the undersigned, hereby declare that the equipment specified above conforms to the above Directive(s).

MANUFACTURER



Signature
Christopher Perkins

Full Name
Engineering Manager

Position
Woodward, Fort Collins, CO, USA

Place

Ø1 - JUN - 2016

Date

5-09-1183 Rev 26

EU DECLARATION OF CONFORMITY

EU DoC No.: 00383-04-EU-02-01
Manufacturer's Name: WOODWARD INC.
Manufacturer's Contact Address: 1041 Woodward Way
 Fort Collins, CO 80524 USA
Model Name(s)/Number(s): CPC-II

The object of the declaration described above is in conformity with the following relevant Union harmonization legislation: Directive 2014/34/EU on the harmonisation of the laws of the Member States relating to equipment and protective systems intended for use in potentially explosive atmospheres

Directive 2014/30/EU of the European Parliament and of the Council of 26 February 2014 on the harmonization of the laws of the Member States relating to electromagnetic compatibility (EMC)

Markings in addition to CE marking: Category 2 Group II G, Ex d Gas Group IIB, T4 Gb
 Category 3 Group II G, Ex nA Gas Group IIC, T4 Gc IP66

Applicable Standards: EN61000-6-2, 2005: EMC Part 6-2: Generic Standards - Immunity for Industrial Environments
 EN61000-6-4, 2007/A1:2011: EMC Part 6-4: Generic Standards - Emissions for Industrial Environments
 EN60079-0, 2012/A11:2013: Explosive Atmospheres - Part 0: Equipment - General requirements
 EN60079-15, 2010: Explosive Atmospheres - Part 15: Equipment protection by type of protection "n"
 EN60079-1, 2007 : Explosive Atmospheres - Part 1: Equipment protection by flameproof enclosures "d"

Third Party Certification: SIRA 11 ATEX 1310X
 SIRA (0518)
 Rake Lane, Eccleston, Chester, CH4 9JN
 UK

Conformity Assessment: ATEX Annex IV - Production Quality Assessment, 01 220 113542
 TUV Rheinland Industrie Service GmbH (0035)
 Am Grauen Stein, D51105 Cologne

This declaration of conformity is issued under the sole responsibility of the manufacturer
 We, the undersigned, hereby declare that the equipment specified above conforms to the above Directive(s).

MANUFACTURER

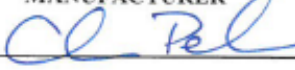

Signature

Christopher Perkins

Full Name

Engineering Manager

Position

Woodward, Fort Collins, CO, USA

Place

01 - JUN - 2016

Date

5-09-1183 Rev 26

We appreciate your comments about the content of our publications.

Send comments to: icinfo@woodward.com

Please reference publication **26758**.



B 2 6 7 5 8 : B



PO Box 1519, Fort Collins CO 80522-1519, USA
1041 Woodward Way, Fort Collins CO 80524, USA
Phone +1 (970) 482-5811

Email and Website—www.woodward.com

Woodward has company-owned plants, subsidiaries, and branches, as well as authorized distributors and other authorized service and sales facilities throughout the world.

Complete address / phone / fax / email information for all locations is available on our website.