

# TG-13E and TG-17E

## Actuators

### Applications

The TG-13E and 17E actuators are self-contained electrohydraulic actuators for use on steam turbines where isochronous control, load sharing, or other functions are required. They can be used with all available Woodward electronic governor controls and accessories.

### Description

The TG-13E and 17E proportional electro-hydraulic actuators convert an electrical signal to a corresponding proportional output shaft position to position the valve which controls the flow of steam or energy medium to the turbine. They are intended for controlling small steam turbines driving such loads as alternators, dc generators pumps, compressors, fans or paper-making machines. The actuators provide the "muscle" for a Woodward 2301, 2500, 501 (with a digital remote final driver), or similar integrating electronic control system. The actuators provide a mechanical output position in proportion to a dc control signal.

### Standard Features

Critical moving parts are made from either heat treated or hardened steels. All O-rings and shaft seals are made of a fluorocarbon material, All moving parts are submerged in oil. The actuator has a self-contained oil sump.

### Special Features

The actuators are equipped with an oil pump and must be driven either by the turbine or other means, such as an electric motor. Factory adjustments allow the actuators to be calibrated over given ranges of input signal consistent with the type of controls in which they are used.

### Optional Equipment

The standard model requires a mechanical drive, however a unit is available which requires only a customer-supplied hydraulic pressure source.

Class I, Division 2, Groups B, C, and D UL Listed actuators are available.

**NOTE**—Unless otherwise specified, TG-13E and -17E actuators are calibrated for vertical operation. When used in a horizontal application these actuators will have approximately a 5° to 6° shift in terminal shaft calibration. Breather cap location must also be changed. (See outline drawing for breather cap location.)



- Proportional electric mechanical transducer
- Rotary output
- 12.2 and 17.5 lb-ft (16.5 and 23.7 N·m) work capacity
- Self-contained oil sump
- UL Listed model available
- Adjustable feedback

## Specifications

---

### GOVERNOR DRIVE

**Shaft** 1/2" dia. Number 5 Woodruff key (1/8")

**Speed Range** The pump is sized to operate over the following ranges:

1100 to 2400 rpm

2400 to 4000 rpm

4000 to 6000 rpm

Different actuator part numbers are required for different ranges.

**Drive Power Requirement** 1/3 to 1/2 hp (249 to 373 W) required to turn drive shaft at rated speed

**Rotation** Clockwise or counterclockwise, as viewed from top of actuator; rotation can be changed by removing four screws and rotating pump housing 180°

**Work Output** MAXIMUM WORK CAPACITY OVER FULL GOVERNOR TRAVEL OF 42° IS \* FT-LBS. SEE FIGURE 1 FOR RECOMMENDED GOVERNOR OUTPUT TRAVEL. IN SPECIAL APPLICATIONS MIN AND MAX PRIME MOVER STOPS MAY BE OUTSIDE THE GOVERNOR STOPS.

\* TG-13E 12.2 ft-lbs (16.5 N·m)

\* TG-17E 17.5 ft-lbs (23.7 N·m)

**Output Shaft** 0.625-36 serration on both sides of case

**Calibration** 1° to 3° off minimum shaft position at 20mA and 37° to 39° shaft position at 160 mA

### CONTROL QUALITIES

Actuators will meet NEMA D requirements if used with the proper electronic controls

**Time Constant Shaft Driven** 0.090 s at 150 psig (1034 kPa) operating pressure

**Hysteresis** Within 3% of maximum stroke

**Linearity** Within 0.5%

**Temperature Drift** Nominally  $\pm 2^\circ$  of output shaft position per 100°

**Operating Temperature** 0 to 200 °F (-18 to +93 °C) with proper viscosity oil

### PILOT VALVE

**Plunger Movement** The pilot valve is actuated hydraulically by varying the oil flow from a nozzle. The flapper, which is controlled by the transducer, varies the flow of oil from the nozzle causing a pressure change above the differential power land, forcing it to move. Oil is then directed to or from the power piston, changing the restoring spring forces until the pilot valve is returned to its null position.

**Feedback** Adjustable

### TRANSDUCER COIL

**Coil Resistance** 30 to 35  $\Omega$  at 68 °F (20 °C)

**Maximum Allowable Current** 400 mA

**Nominal Input Current Range** 20 to 160 mA for one or two actuators operating from one electronic control

**Electrical Connector** 4 Pin MIL-STD-1651-14S-2P

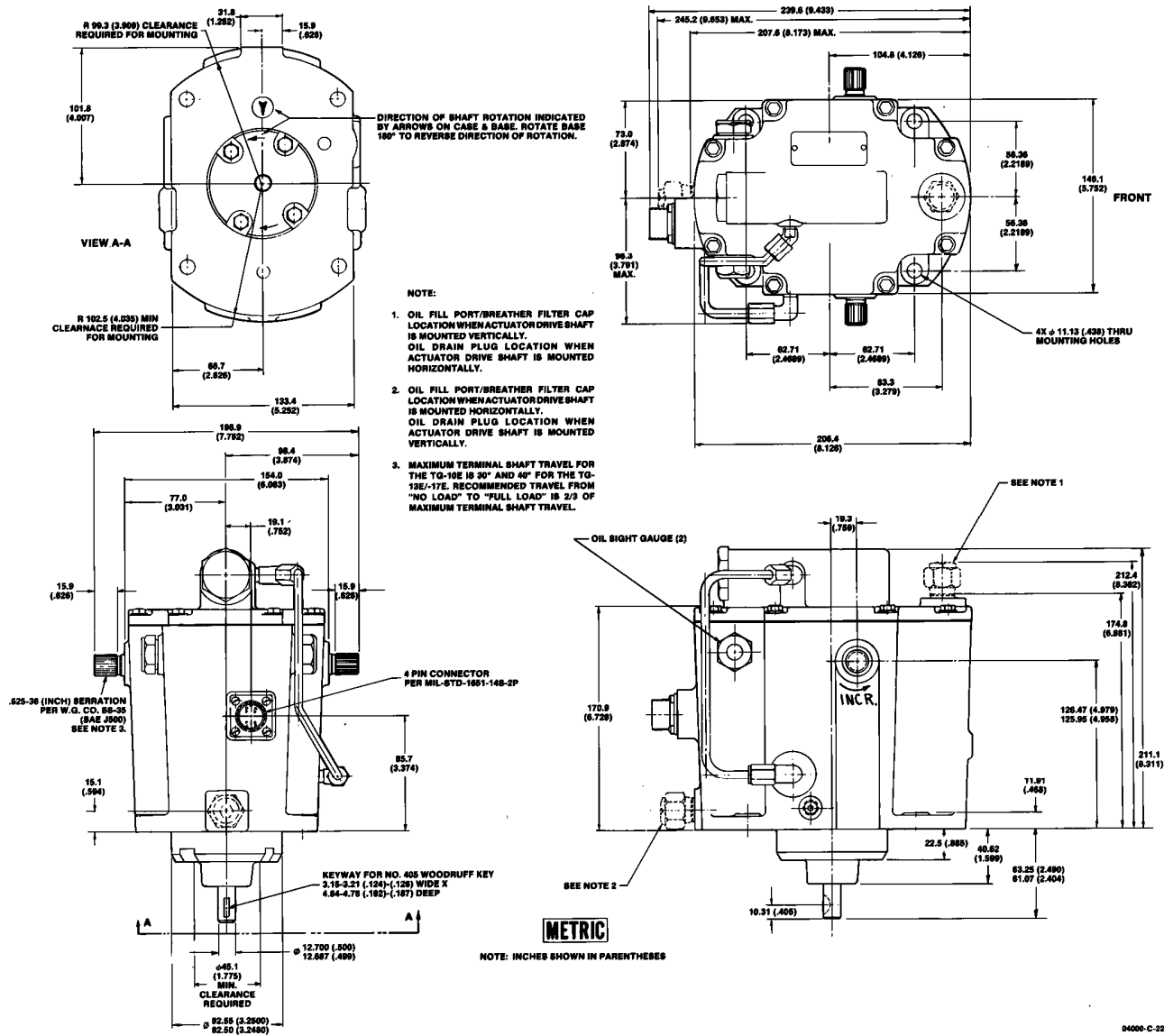

Figure 1. Outline Drawing of TG-13E and TG-17E (Do not use for construction)

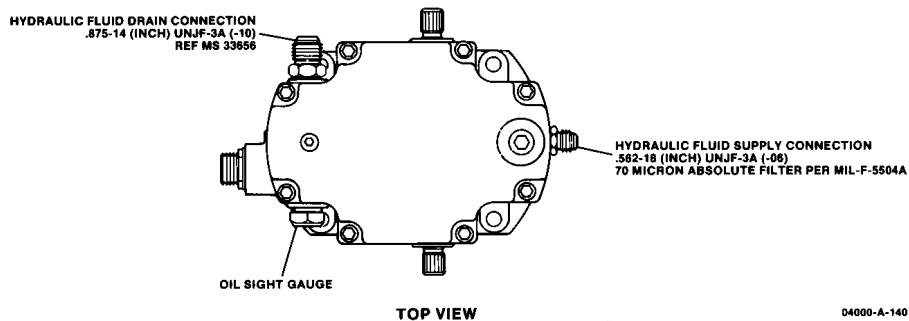

Figure 2. Oil Line Connections for TG-13E and TG-17E Which Require a Customer-Supplied Hydraulic Pressure Source, but do not Require a Drive

**HYDRAULIC SYSTEM**

Oil Self-contained sump; SAE 10 to 50 is recommended with a viscosity of 100 to 300 to SUS, depending on operating temperature. See Woodward oil manual 25071 for recommended oils.

**Relief Valve** Integral part of accumulator and maintains 150 psi (1034 kPa) for the TG-13E and 200 psi (1379 kPa) from the TG-17E

**Capacity** 1.75 quarts (1.7 L)

**Filtration** Removable oil filter element in cover for all actuators except external hydraulic supply

**External Hydraulic Supply (for unit not requiring a drive)** 1 to 4 USgal/min (3.8 to 15 L/min) supply flow to regulate accumulator between 150 and 170 psi (1034 and 1172 kPa). Supply must be filtered to 25  $\mu$ m (absolute). Actuator is fitted with a -6 filter fitting (70  $\mu$ m absolute) and a -10 drain fitting.

## CONSTRUCTION

**Case, Pump Housing, & Cover** Aluminum

**Weight** 16 lb (7 kg)

**Internal Parts** Aluminum, mild and/or case-hardened steel

## MOUNTING

**Attitude** Vertical or horizontal (power servo down)

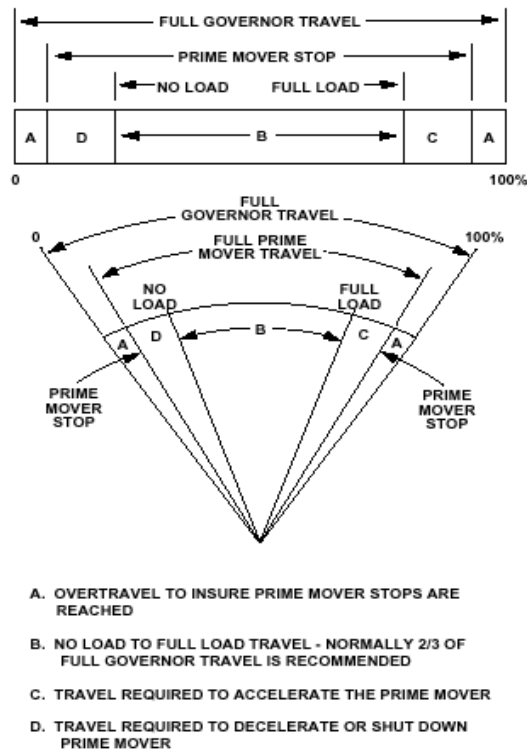

Mac/Dsk/1

**Figure 3. Recommended Governor Output Travel**



PO Box 1519, Fort Collins CO, USA 80522-1519  
 1000 East Drake Road, Fort Collins CO 80525  
 Tel.: +1 (970) 482-5811 • Fax: +1 (970) 498-3058  
[www.woodward.com](http://www.woodward.com)

### Distributors & Service

Woodward has an international network of distributors and service facilities. For your nearest representative, call the Fort Collins plant or see the Worldwide Directory on our website.

This document is distributed for informational purposes only. It is not to be construed as creating or becoming part of any Woodward Governor Company contractual or warranty obligation unless expressly stated in a written sales contract.

© Woodward 2000, All Rights Reserved

For more information contact:

2009/2/Fort Collins