

TG-13 Governors

for Ajax Engines

Applications

The two TG-13 Governor models for combustion engines are self-contained mechanical-hydraulic governors and are intended for use where isochronous (constant speed) operation is not required. They are designed to quickly and efficiently replace mechanical governors on Ajax integral engine-compressors used for gas gathering and production.

As efficient speed control devices, the new models significantly reduce speed excursions during load changes. Their ability to stabilize engine operation eliminates both overspeed trips and bogged engines, which result from changing load conditions. In addition to improved engine operation, an operator often can realize reduced governor-service and governor-maintenance costs.

Description

Simplicity and low cost are distinct advantages of the TG-13 Governors. The governors operate with speed droop for stability of control and allow the engines to run unattended.

An internal oil pump, driven by the governor's drive shaft, transports oil from the self-contained sump. Internal pressure is maintained by a relief valve accumulator system. The unit can use the same type of lube oil as the engine. A sight glass provides ease in checking oil level. The built-in relief valve accumulator helps maintain full oil pressure in the governor hydraulic system during transient conditions.

The two governor models are identical except for the base and the drive shaft length. Both models are easily installed, require no modifications to engine mounting pad, and generally use existing linkage. Once installed, they require minimal maintenance.

Two types of speed-setting adjustments are available: Screw speed setting is standard, and pneumatic speed setting is optional.

Weather-resistant construction and a self-contained oil sump reduce, if not eliminate, the possibility of contamination.



- Self-contained mechanical/hydraulic governor
- Low cost
- Accurate speed control
- Weather resistant
- 16 N·m (12 lb-ft) output
- Pneumatic speed setting available

Specifications

Speed Setting

Screw Adjustment on top of cover
 Optional Pneumatic Direct acting, 21 to 103 kPa (3 to 15 psi)

Governor Drive

Shaft 1/2-in. (12.7 mm) diameter. Number 5 Woodruff key (1/8 in. [3.2 mm])
 Speed Range Can be adjusted with a high speed of 1850 rpm and a low speed of 740 rpm (engine speed 500 to 200 rpm)
 Drive Power Requirement 373 W (1/2 hp) maximum required to turn drive shaft at rated speed
 Rotation Counterclockwise as viewed from the top of the governor

Output

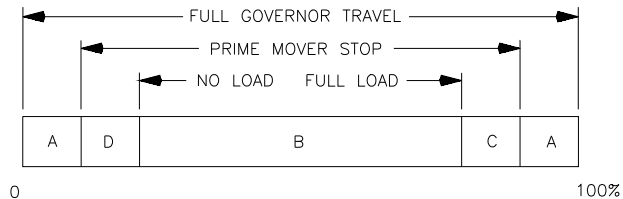
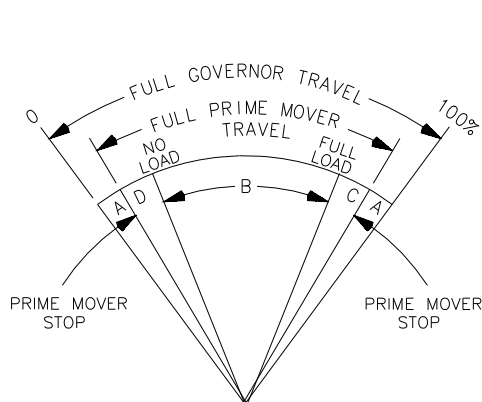

- A - OVERTRAVEL TO INSURE PRIME MOVER STOPS ARE REACHED.
 B - NO LOAD TO FULL LOAD TRAVEL - NORMALLY 2/3 OF FULL GOVERNOR TRAVEL IS RECOMMENDED.
 C - TRAVEL REQUIRED TO ACCELERATE THE PRIME MOVER.
 D - TRAVEL REQUIRED TO DECELERATE OR SHUT DOWN PRIME MOVER.
- MI-153a
98-04-14 skw

MAXIMUM WORK CAPACITY OVER FULL GOVERNOR TRAVEL OF 42' IS * . SEE ABOVE FOR RECOMMENDED GOVERNOR OUTPUT TRAVEL. IN SPECIAL APPLICATIONS MIN AND MAX PRIME MOVER STOPS MAY BE OUTSIDE THE GOVERNOR STOPS.

Output Shaft .625-36 serration (extends on both sides of case)

Control Characteristics

Steady State Speed Band $\pm 0.75\%$ of rated speed
 Droop Internally adjustable and must be set as required for stability. Factory set at 6% for 20 degrees terminal shaft travel.
 Operating Temperature Continuous operating temperature: 60 to 93 °C (140 to 200 °F). Ambient temperature: -29 to +93 °C (-20 to +200 °F). Contact Woodward if operating beyond these limits.

Hydraulic System

Oil Self-contained sump. When governor is at operating temperature, oil with a viscosity of 100 to 300 SUS is recommended. See Woodward Manual 25071, *Oils for Hydraulic Controls*, for more information on oils.
 Capacity: 1.7 L (1.75 quarts)

Construction

Case and Pump Housing die cast aluminum
 Standard Cover Cast aluminum (screw speed setting governor)
 Optional Cover Sand cast aluminum (pneumatic speed setting governor)
 Weight 7 kg (16 lb) (8 kg/18 lb with optional pneumatic speed-setting device)
 Internal Parts Aluminum, mild, and/or case-hardened steel

Mounting

Attitude Vertical or horizontal (breather cap up)

References

Manual 04042, *TG-13 and TG-17 Governors*
 Manual 25071, *Oils for Hydraulic Controls*

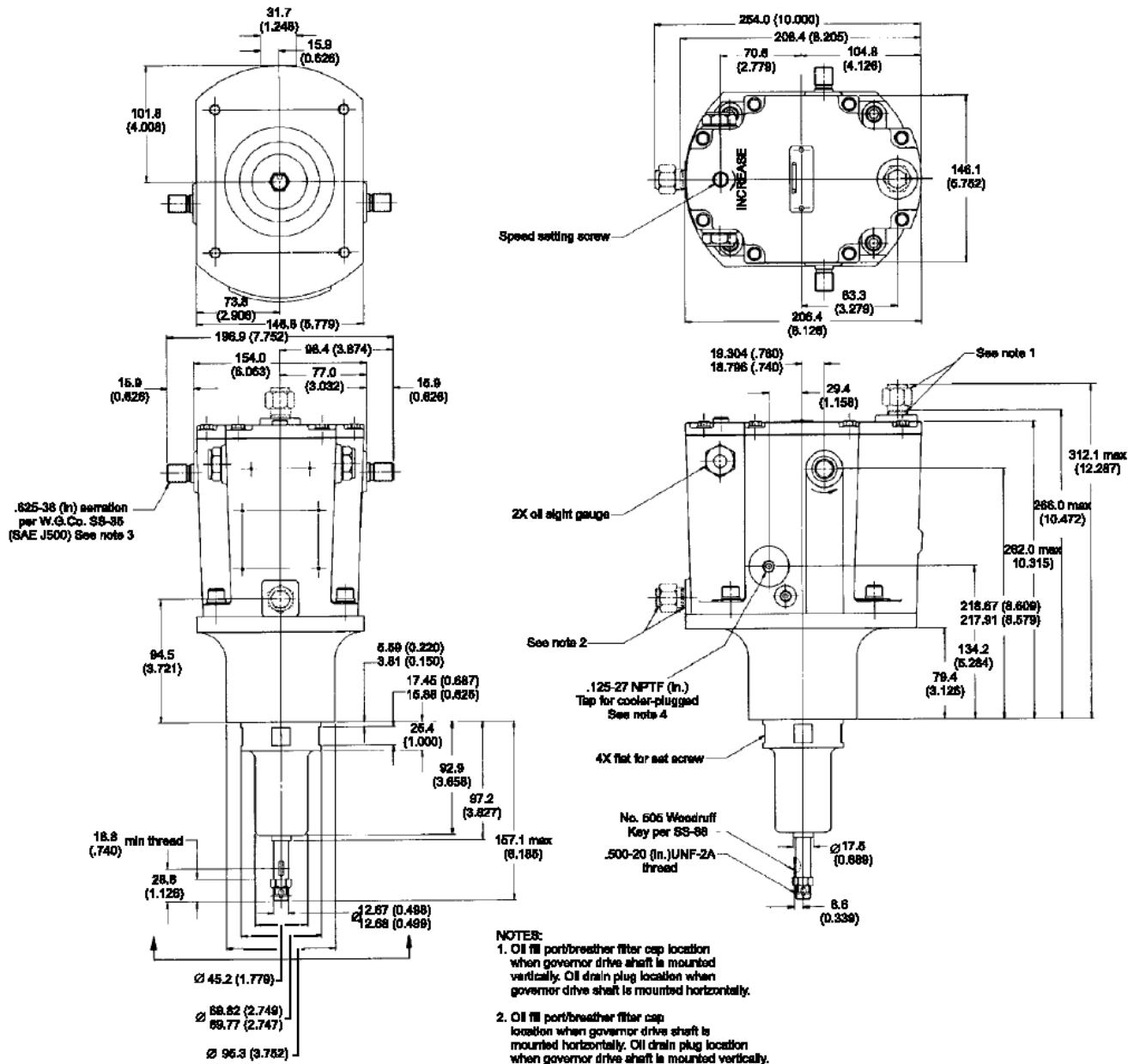

METRIC

INCHES IN PARENTHESIS

- NOTES:
1. Oil fill port/breather filter cap location when governor drive shaft is mounted vertically. Oil drain plug location when governor drive shaft is mounted horizontally.
 2. Oil fill port/breather filter cap location when governor drive shaft is mounted horizontally. Oil drain plug location when governor drive shaft is mounted vertically.
 3. Terminal output shaft max available stroke is 40°. Recommended strokes from no load to full load is 25° - 30°.
 4. Cooler tap output (used on 8000 RPM governor). Cooler return to be connected to governor drain.

040-180
88-08-11 skw

Outline Drawing of TG-13 Governor (Ajax SGL)
(Do not use for construction)

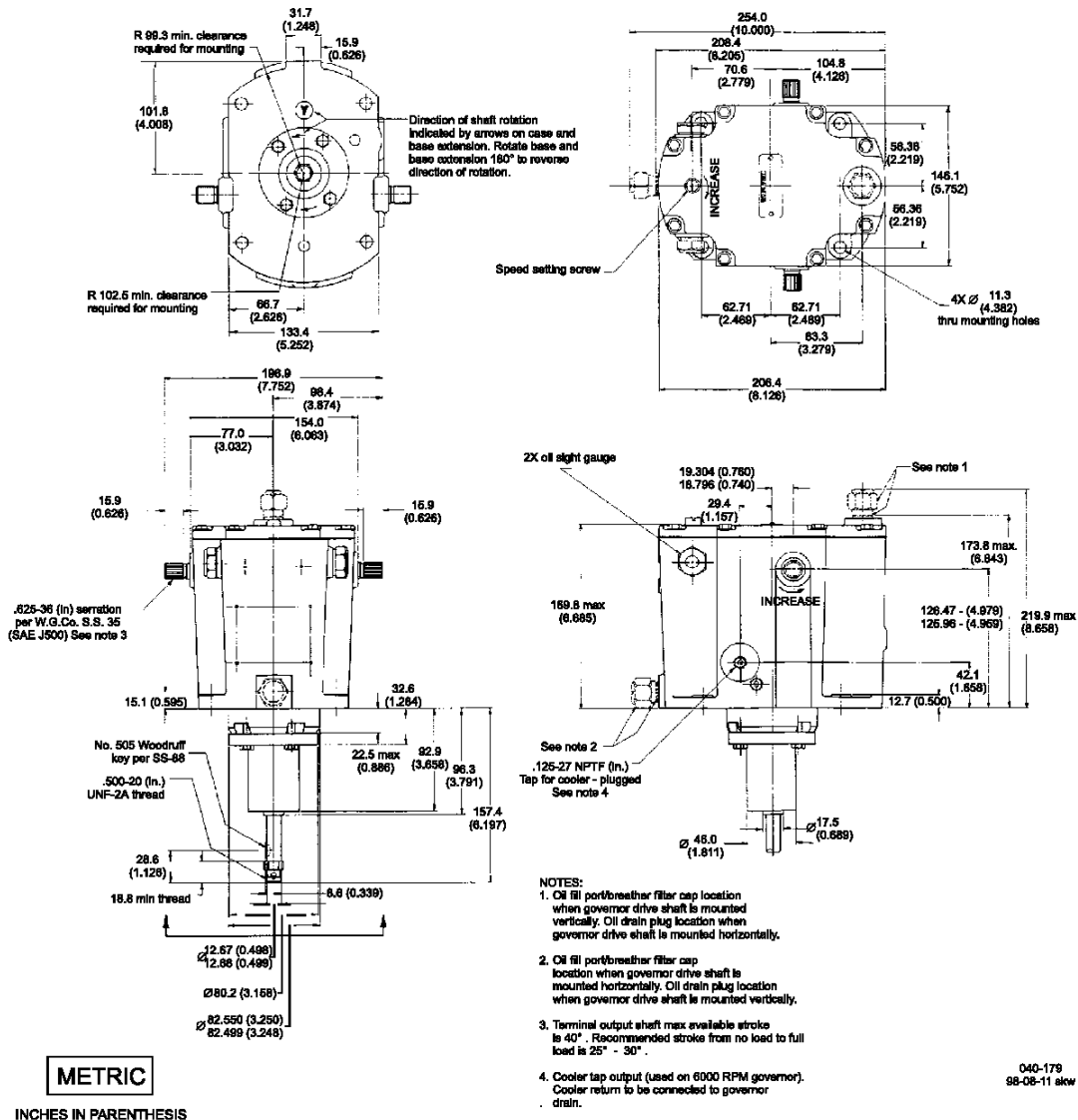

Outline Drawing of TG-13 Governor (Ajax MULT)
(Do not use for construction)

WOODWARD
PO Box 1519, Fort Collins CO, USA 80522-1519
1000 East Drake Road, Fort Collins CO 80525
Tel.: +1 (970) 482-5811 ♦ Fax: +1 (970) 498-3058
www.woodward.com

Distributors & Service

Woodward has an international network of distributors and service facilities. For your nearest representative, call the Fort Collins plant or see the Worldwide Directory on our website.

This document is distributed for informational purposes only. It is not to be construed as creating or becoming part of any Woodward Governor Company contractual or warranty obligation unless expressly stated in a written sales contract.

© Woodward 1987, All Rights Reserved

For more information contact: