

PG-PL Governor

Applications

The PG-PL Governor is widely used for controlling speed for all types of diesel or gas engines and steam turbines, driving pumps and compressors.

Standard Features

An internal oil pump, relief-valve, and accumulator system controls governor operating pressure. A self-contained sump stores oil and reduces contamination from outside sources.

Oil flow to and from the governor cylinder assembly is controlled by a centrifugal flyweight-head and pilot-valve assembly. A power cylinder (servomotor) positions the fuel racks, fuel valve, or steam valve of the engine or turbine.

A pneumatic (direct or reverse) operated bellows-type mechanism sets governor speed. A knob on the governor provides a means of manual speed adjustment. Governor stability is provided by an adjustable needle valve and spring-loaded buffer compensation system.

Optional Features

An oil cooler is recommended when governor oil temperature exceeds 99 °C (210 °F) or governor drive shaft speed exceeds 1200 rpm on diesel or gas engines, or 1100 rpm on steam turbines.

Air, oil, or water shutdown devices, either high or low pressure, are available for engine protection. An energize or de-energize solenoid shutdown device is also available.

For quick starts, a booster servomotor is available to supply immediate oil pressure to the governor. This conserves engine starting air.

Preloaded buffer springs are available for governors used on gas engines and on some engines driving reciprocating pumps.

Various base and power cylinder assemblies are available to conform to engine or turbine manufacturer's specifications.

Power servos may be mounted integrally on the governor with the terminal shaft in either the 3, 6, 9, or 12 o'clock positions. Power servos also may be mounted remotely from the governor. However, rotary power servos mount vertically only.



- Isochronous control
- Pressure compensated
- 16 to 79 J (12 to 58 ft-lb) output capacities
- Remote power servos
- Pneumatic or manual speed setting
- Rotary or linear output
- Self-contained sump

Specifications

Speed Setting

Manual	Control knob on governor
Pneumatic	Direct or reverse. With 21 kPa (3 psi) minimum and 690 kPa (100 psi) maximum control air pressure. Ratio of max. to min. air control signal pressure must be greater than 2.5 to 1, but less than 10 to 1. Typical pneumatic ranges are 21 to 103 kPa (3 to 15 psi) and 69 to 414 kPa (10 to 60 psi). 0.25 inch (6.4 mm) SAE air connection.

Bellows Selections (for pneumatic speed setting)

Bellows	400 mm ² (0.62 in ²)	194 mm ² (0.3 in ²)	77 mm ² (0.12 in ²)
Max signal pressure	138 kPa (20 psig)	138 to 345 kPa (20 to 50 psig)	345 to 827 kPa (50 to 120 psig)
Min signal pressure	21 kPa (3 psig)	48 kPa (7 psig)	69 kPa (10 psig)

Governor Drive

Input Shaft	Keyed or 1.125" - 48 serrated.
Recommended Speed Range	250 rpm minimum to 1000 rpm maximum. Speeds in excess of 1000 rpm are available but require single direction rotation. Oil coolers may also be required. Please consult Woodward.
Maximum Speed Range	The absolute minimum speed is 200 rpm. The absolute maximum speed is 1600 rpm.
Power Requirement	373 W (0.5 hp), typical maximum
Rotation	Fixed clockwise, fixed counterclockwise, or reversible

Output

Power Cylinder Type and Travel	Linear with 1-inch (25 mm) maximum travel or rotary with 30 degrees maximum travel. When making connection to engine or turbine linkage, use 2/3 of the available governor terminal shaft travel between no load and full load. Split overtravel at each end so that the governor can shut down the prime mover and also give maximum fuel when required.
--------------------------------	---

Maximum (stalled) Work Capacity:

Governor Operating Oil Pressure Servo	Work Capacities	
	16 J (12 ft-lb) Servo	39 J (29 ft-lb) Servo
690 kPa (100 psi) (std.)	16 J (12 ft-lb)	39 J (29 ft-lb)
1379 kPa (200 psi)	33 J (24 ft-lb)	79 J (58 ft-lb)
Usable Work	Standard governors, 11 J (8 ft-lb) or 2/3 of maximum work	

Pilot Valve

Plunger Movement	Balanced between ballhead centrifugal force and speeder-spring force
Bushing	Rotated integrally with governor drive shaft
Porting	4 round or 3 slotted

Control Characteristics

Steady State Speed Band	±0.25% of rated speed (under normal operating conditions)
Ballhead Assemblies	Solid or spring driven oil damped
Operating Temperature	Continuous operating temperature is 60 to 93 °C (140 to 200 °F). Consult Woodward beyond these limits. Hydraulic pour point must be below lowest expected starting temperature.

Hydraulic System

Oil	SAE 10 to 50 oil depending on temperature
Viscosity	100 to 300 SUS under normal operating conditions
Self-Contained Sump Capacity	Approximately 1.4 L (1.5 qt)
Relief Valves	690 to 1379 kPa (100 to 200 psi)
Operating Pressure	690 kPa (100 psi) normal, 1379 kPa (200 psi) optional

Construction

Weight	Approximately 36 kg (80 lb)
Case and Base	Cast iron
Column	Cast aluminum

Mounting

Configuration	Vertical
---------------	----------

References

Manual	36694, <i>PG-PL Governors</i>
--------	-------------------------------

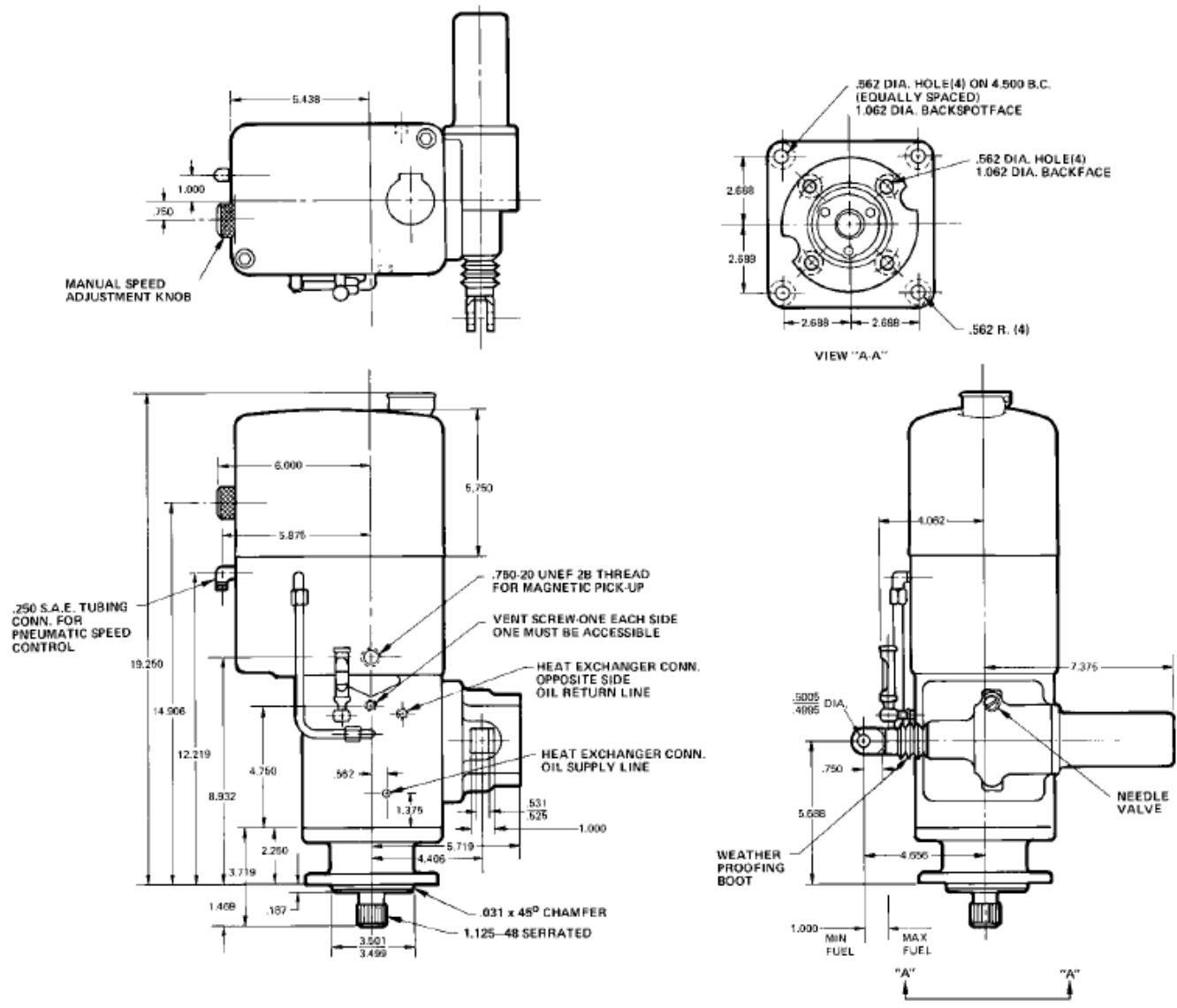

PG-PL Governor Outline Drawing
 (shown with 12 ft-lb linear servo/horizontal)
 (Do not use for construction)

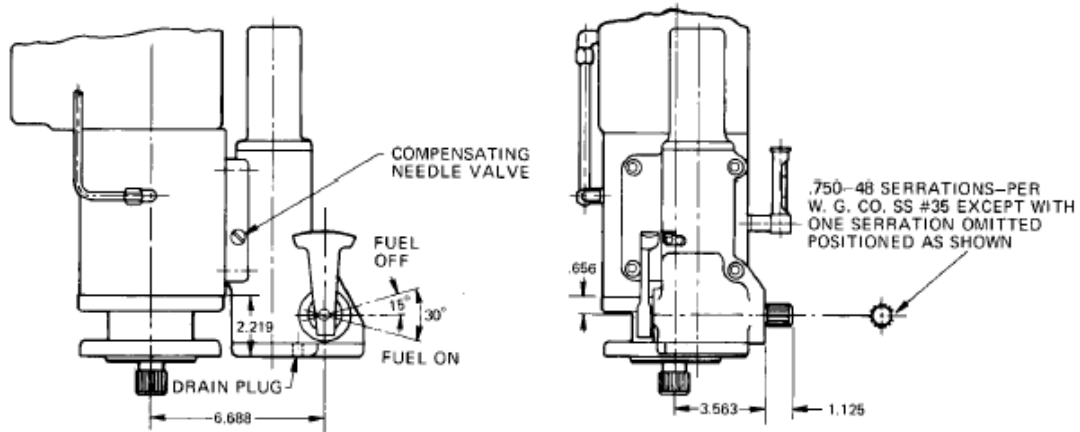

12 Ft-Lb Spring Loaded Rotary Power Servo

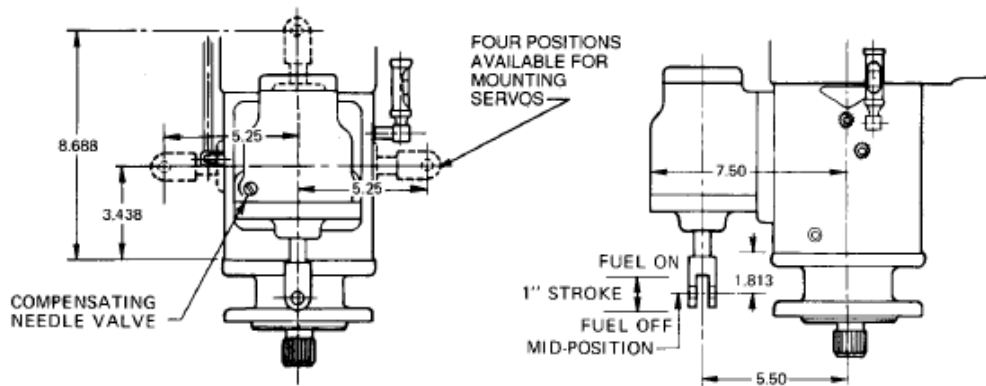

29/58 ft-lb Differential Power Servo (linear output)
(Do not use for construction)



PO Box 1519, Fort Collins CO, USA 80522-1519
1000 East Drake Road, Fort Collins CO 80525
Tel.: +1 (970) 482-5811 ♦ Fax: +1 (970) 498-3058
www.woodward.com

Distributors & Service

Woodward has an international network of distributors and service facilities. For your nearest representative, call the Fort Collins plant or see the Worldwide Directory on our website.

This document is distributed for informational purposes only. It is not to be construed as creating or becoming part of any Woodward Governor Company contractual or warranty obligation unless expressly stated in a written sales contract.

© Woodward 1972, All Rights Reserved

For more information contact:

2009/4/Fort Collins