

EGB-1P and EGB-2P

Governor/Actuator

Applications

The EGB-2P and EGB-1P are for use with Woodward electronic controls or similar systems where a backup ballhead governor is desirable.

Standard Features

The EGB-2P and EGB-1P are proportional electro-hydraulic actuators combined with isochronous or droop mechanical-hydraulic ballhead governors.

While proportional actuators can be used in the same type of service as other actuator models, they are particularly well suited to engines operating in tandem to drive a common load.

The EGB-1P is used in high-performance applications requiring fast-acting responses with lower work output. The EGB-1P has the same mounting pad, drive shaft, and terminal shaft configuration as the EGB-2P. Internal parts are also identical except for the EGB-1P's smaller power piston.

The essential element of the actuator section is the electro-mechanical transducer. The transducer responds to the output from the electronic governor control and moves the pilot valve plunger. Pressurized oil is then directed to the actuator power piston to actuate the fuel or steam control. The pilot valve plunger movement on the actuator is balanced between transducer coil force and restoring spring force. On the governor, plunger movement is balanced between ballhead centrifugal force and speeder spring force. The pilot valve bushing is mechanically driven by the prime mover as an integral part of the governor drive shaft.

These EGBs are available with either a direct- or a reverse-acting actuator.

The direct-acting actuator operates with an electronic control which sends an increasing positive voltage to the actuator as fuel requirements increase. The terminal shaft of the direct-acting actuator will shut down the prime mover if the input voltage from the speed control is lost, thus providing a failsafe feature. However, ballhead governing will not start on its own. Operator intervention is required.

The reverse-acting actuator operates with electronic controls which send a decreasing positive voltage to the actuator as fuel requirements increase. The terminal shaft of the reverse-acting actuator goes to maximum fuel on loss of control voltage. The transfer from electrical actuator operation to ballhead governor operation takes place on its own. This is not meant to imply that an automatic operational transfer will take place (same speed setting, same load sharing capability—see Woodward Application Note 50507 for more information.)

The terminal shaft can be mounted on either or both sides of the case.

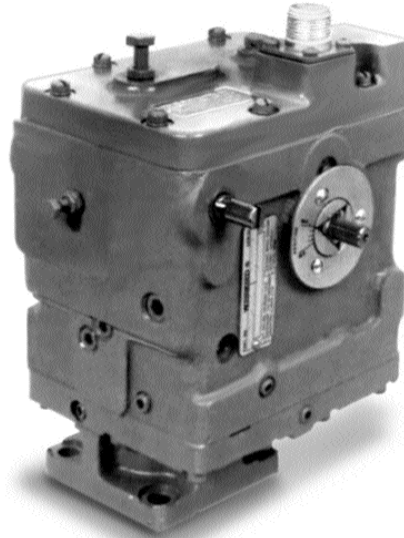

- Electrohydraulic actuator
- Mechanical-hydraulic governor
- Single or tandem operation
- Direct-acting or reverse-acting actuator output

The governor section has three operating adjustments. Once set, these adjustments usually do not require further adjustment.

- SPEED SETTING—either shaft or screw for external manual adjustment.
- SPEED DROOP—internally adjusted to permit parallel operation of units controlled by the centrifugal governor.
- NEEDLE VALVE—an external adjustment used to stabilize the centrifugal governor.

Special Features

Either a mechanical override or a pneumatic override device is available to provide a means of locking out the actuator pilot valve plunger. These devices are very useful for some start-ups, or if an electrical supply is temporarily unavailable or has failed.

The schematic diagram gives a simplified view of the oil passages to better illustrate the operation of the governor/actuator.

Specifications

Output

Terminal Shaft	0.375 in. - 36 SAE serrations, or smooth with keyway, either side or both sides of case.
Calibration	Direct-acting, (reverse-acting in parentheses). With a 20 mA current to the actuator terminals, adjust the terminal shaft 1 to 2 degrees from minimum (maximum) fuel position. Increase current to 160 mA. Observe $29 \pm 0.5^\circ$ travel from minimum (maximum) shaft position.
Linkage	Recommended utilization angle of 21° for full load to no load. Relation between engine torque output and terminal shaft travel should be approximately linear.

Governor/Actuator Drive

Shaft	0.562 in - 6 spline
Speed Range	1200 to 4000 rpm
Recommended Speed Range	2600 to 4000 rpm
Minimum Power	249 W (1/3 hp) to turn drive shaft at 3600 rpm normal operating speed and temperature
Rotation	Clockwise and/or counterclockwise

Control Characteristics

Governor

Steady State Speed Band	$\pm 0.25\%$ of rated speed
Droop	Can be set from 0% to 12% over full output travel. Internal adjustment.
Ballhead Assemblies	Solid or spring-driven vibration damping type. Available in un-damped natural frequencies of 0, 1.7, 3.0, 4.8, 6.7, or 9.2 Hz (C.P.S.)
Operating Temperature	-18 to $+93^\circ\text{C}$ (0 to $+200^\circ\text{F}$) (with proper viscosity oil)

Actuator

Time Constant (Shaft Driven)	EGB-1P: 48 ms (nominal) at 2400 kPa (350 psi) operating pressure EGB-2P: 100 ms (nominal) at 2400 kPa (350 psi) operating pressure
Hysteresis	Within 3%
Linearity	Within 0.5%

Transducer Coil

Coil Resistance	30 to 35 Ω at 20°C (68°F)
Maximum Allowable Current	200 mA during normal operation
Nominal Input Current Range	20 to 160 mA
Recessed Plug	MS-3106A 12S-3S

Hydraulic System

Supply Oil	Hydrocarbon or synthetic oil. Synthetic oil only with special precautions (contact Woodward)
Source	Engine lubricating system or a separate sump
Supply Pressure	Minimum 10 in. water suction. Maximum 345 kPa (50 psi)
Operating Pressure	2100 to 2400 kPa (300 to 350 psi) (plus supply oil pressure)
Filter	20 to 25 μm for 7.6 L/min (2 gal[US]/min)
Viscosity	100 to 300 SUS at normal operating temperature
Flow	EGB-1P—peak demand of 5.7 L/min (1.5 gal[US]/min) during transients; steady state flow 1.70 L/min (0.45 gal[US]/min) (nominal) at 2400 kPa (350 psi) and 60 SUS EGB-2P—peak demand of 7.6 L/min (2.0 gal[US]/min) during transients; steady state flow 2.27 L/min (0.60 gal[US]/min) (nominal) at 2400 kPa (350 psi) and 60 SUS
Piping	9.5 mm (3/8 inch) minimum

Construction

Case and Base	Cast-iron
Cover	Cast aluminum
Weight	9 to 10 kg (20 to 22 lb)

Mounting

Configuration	Vertical (or horizontal with proper adjustments)
Studs	5/16 inch (7.9 mm) diameter (4)

Reference

Manual 82570, EGB-2P and EGB-1P Governor/Actuator

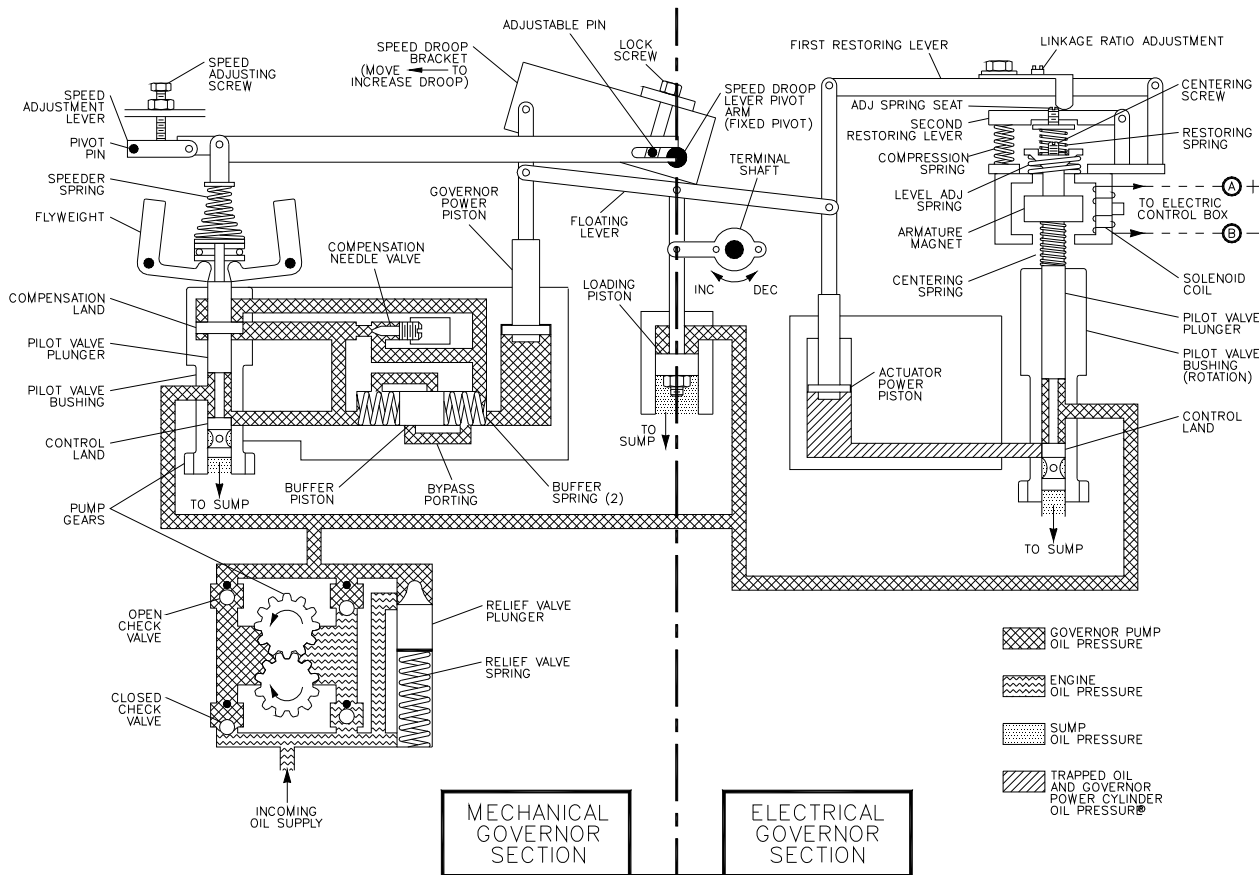

MISC-2464
93-08-31 RAM

EGB-2P Governor/Actuator Schematic Diagram

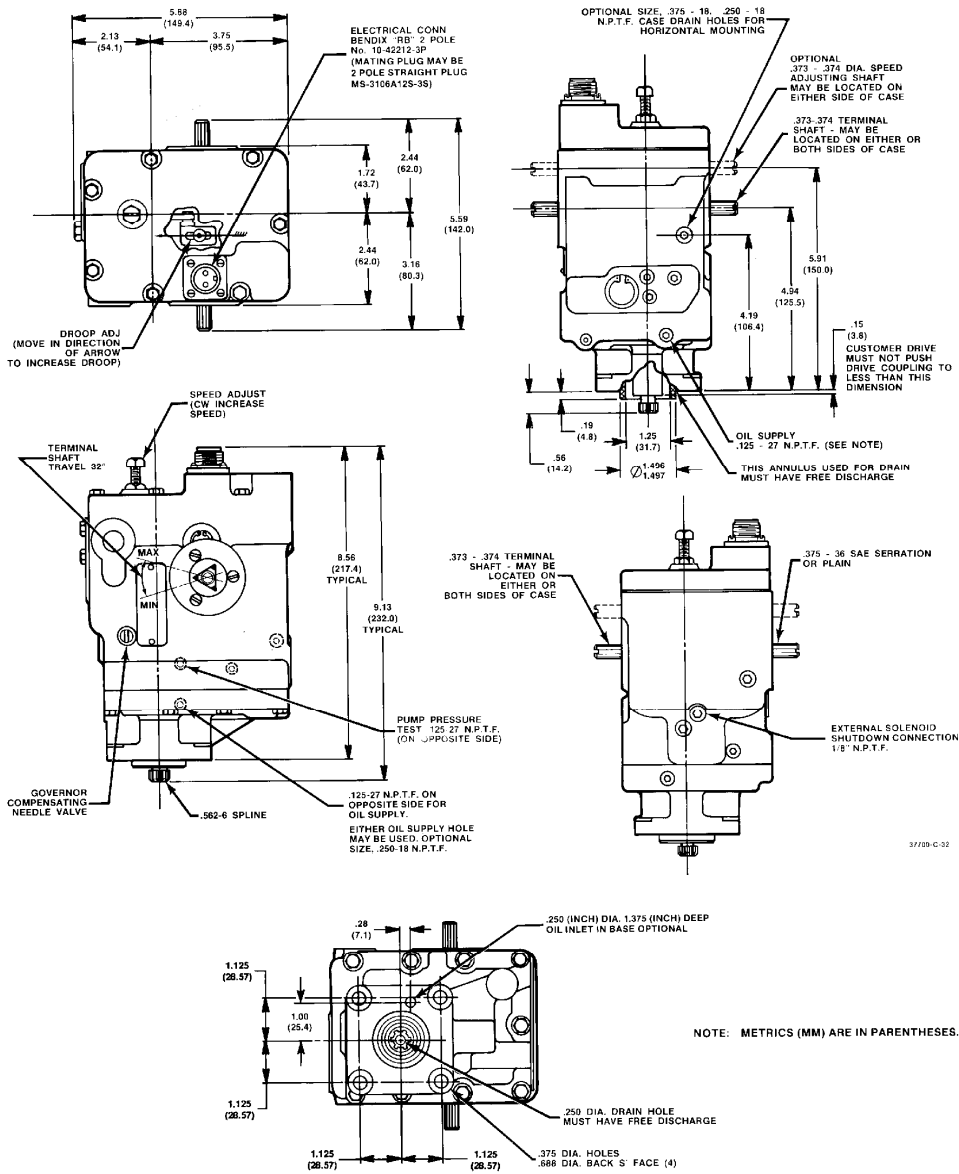

EGB-2P Governor/Actuator Outline Drawing
(Do not use for construction)



PO Box 1519, Fort Collins CO, USA 80522-1519
1000 East Drake Road, Fort Collins CO 80525
Tel.: +1 (970) 482-5811 ♦ Fax: +1 (970) 498-3058
www.woodward.com

Distributors & Service

Woodward has an international network of distributors and service facilities. For your nearest representative, call the Fort Collins plant or see the Worldwide Directory on our website.

This document is distributed for informational purposes only. It is not to be construed as creating or becoming part of any Woodward Governor Company contractual or warranty obligation unless expressly stated in a written sales contract.

© Woodward 1974, All Rights Reserved

For more information contact:

2008/8/Fort Collins