

QuickTrip

Electro-hydraulic Trip Block Assembly

Applications

The QuickTrip trip block assembly is designed for use in steam, gas, and hydro turbine shutdown systems for quick and reliable dumping of the turbine's trip oil header. This integrated trip block assembly is intended for use on mechanical-drive or generator-drive steam turbines that use low-pressure (5–25 bar / 73–363 psi) hydraulic trip oil headers.

The QuickTrip's fault tolerant design makes it ideal for critical steam turbine applications, where turbine up-time and availability are essential. This trip block assembly's 2-out-of-3 voting design provides users with a very high level of system reliability as well as compliance with industry standard API-670.

This trip block assembly is designed to allow turbine controls and/or turbine safety systems to quickly dump (bleed off) hydraulic header pressure during emergency trip or normal trip conditions. When applied in conjunction with Woodward's ProTechTPS logic solver, the QuickTrip allows users to independently test each trip leg to verify operation and trip time. API-670 5th edition requires that all components except for the final element (trip valve) shall be routinely tested while the turbine is in operation.

With the use of trip solenoids which respond in less than 50 milliseconds, the QuickTrip is designed for steam turbine trip systems where it is imperative the entire trip system shut the system trip valve as quickly as possible.

The QuickTrip's robust design (corrosion resistant materials, three independent moving rotary valves, 25 lb chip shear force, and self-cleaning port design) makes it perfect for challenging applications where dirty or contaminated oil may be present.

The QuickTrip is certified for use in IEC61508 based turbine safety systems, and when paired with the Woodward ProTechTPS, can be applied into systems that require a "Safety Integrity Level – 3" rating or below.

Designed for use in new or retrofit turbine packages, the QuickTrip's compact package size allows it to be located near the turbine and trip & throttle valve, minimizing trip header piping and related system delays. Each trip leg includes bright position indication LEDs (run & trip) to allow turbine operators to quickly verify system status locally near the turbine as well as integrated limit switches for safety system and plant DCS status and health validation.



- Dirt-tolerant design
 - No orifices to plug
 - 25 lb rotary chip shear force
 - Self-cleaning valve design
- Fast trip times
 - < 50 ms solenoid action
- Increased reliability
 - 2-out-of-3 voting design
 - Repairable on-line
 - No single-point failure
 - Testable on-line
- Safety certified for use in IEC61508 SIL-3 systems
- API-670 Compliant
- Local & remote position indications
 - Local—LEDs
 - Remote—Relays
- Compact size
- Certified for hazardous locations
 - CSA Class I, Div. 1 & 2
 - ATEX Zone1 & 2
 - IECEx Zone1 & 2

Description

The QuickTrip is an IEC61508 safety certified electro-hydraulic trip block assembly designed for use in steam turbine shutdown systems for quick and reliable dumping of the turbine's trip oil header. This trip block assembly's 2-out-of-3 voting design provides users with a high level of system reliability as well as compliance with industry standards like API-670, API-612, and API-611.

This trip block assembly is housed in a fully integrated package which includes three patented, dirt-tolerant rotary trip valves. These valves are connected to provide two-out-of-three based voting to ensure that a failure of any one component (valve driver, valve, wiring, connector, etc.) does not result in a nuisance trip condition. The QuickTrip's modular design also allows users to replace critical components (electrical module, solenoid, wiring, driver, etc.) while the turbine is operating on-line.

Designed to quickly and reliably bleed off trip oil header pressure, at least two of the QuickTrip's three rotary solenoid valves must be de-energized to open a bleed path from the trip oil header to system drain (see Figure 1).

The QuickTrip accepts one or two (redundant) 24 Vdc power sources to power each solenoid, and uses three independent discrete input shutdown commands from a safety logic solver like the Woodward ProTechTPS (independent voted models) to test and control each solenoid valve.

Because steam turbines are often used in hazardous locations where flammable gases may be present, the QuickTrip is designed to be mounted next to the steam turbine and is certified for use in Zone-1 or Zone-2 (Class 1 or Class 2) hazardous locations.

When packaged with a Woodward ProTechTPS safety logic solver, the ProTechTPS performs the required routine safety system diagnostic tests to verify unit operation while the turbine is on-line, and the proof test time response monitoring and logging to ensure the total turbine safety system can respond fast enough to safely shutdown the turbine.

The total installed cost for this fully integrated trip block assembly is low because it has been completely assembled and tested at the factory. This greatly reduces OEM and end-user fabrication time, installation time, and testing time.

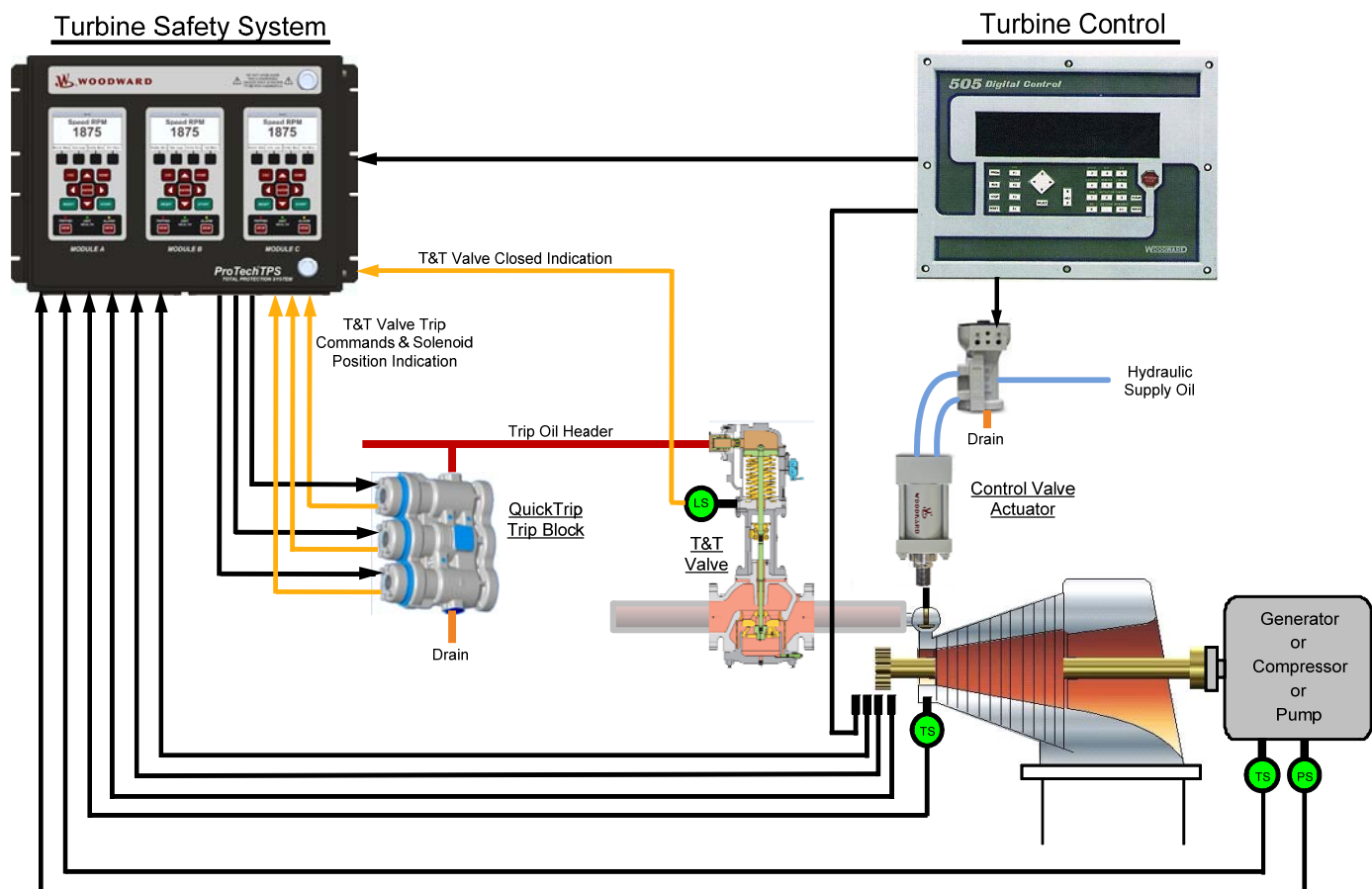

Figure 1. Typical QuickTrip Application

Features

Dirt Tolerance—The QuickTrip is specifically designed for steam turbine applications where turbine lube oil is also used to power the hydraulic turbine control valve actuator(s). Steam turbine applications can be extremely challenging for hydraulic trip block assemblies as dirt, metal shavings, water, and other contaminants (Babbitt, ammonia, etc.) are common in such oil systems. Also due to the high temperatures at which steam turbines operate, turbine oil breakdown is common, resulting in the creation of a sludge-type substance and the varnishing of internal system components. However, the QuickTrip is designed to operate reliably within such challenging applications. Its corrosion-resistant materials, rotary valve design, 25 lb. chip shear force, and self-cleaning ports allow it to operate in such applications without experiencing undesirable sticking or dragging.

In the past, older style trip block assemblies utilized internal orifices and pressure gauges to verify solenoid valve operation, causing many maintenance problems when applied in turbine lube-oil-powered trip systems. Since the QuickTrip does not utilize problematic orifices or pressure gauges, maintenance is reduced and system reliability improved.

Valve Status (local & remote)—Each valve solenoid accepts power for one or two (redundant) power sources and has the following status indications to assist operators with understanding the status and health of each valve.

- Valve Open—Local LED
- Valve Open—Limit Switch
- Valve Closed—Local LED
- Valve Closed—Limit Switch
- Power Supply #1 Healthy – Local LED
- Power Supply #2 Healthy – Local LED

Redundancy/Availability—Designed for use in critical steam turbine applications where turbine up-time is important, the QuickTrip uses three isolated solenoid valves designed to be driven by a triple modular redundant 2-out-of-3 voting based safety logic solver. Each isolated solenoid valve uses redundant power supply inputs to increase both system reliability and availability. Note: Only one power source is required to power/energize each of the isolated solenoid valves.

On-Line Repairable—The QuickTrip's modular design allows repair/replacement of each valve's driver solenoid, electrical module, and associated power supplies and wiring to increase both system reliability and availability.

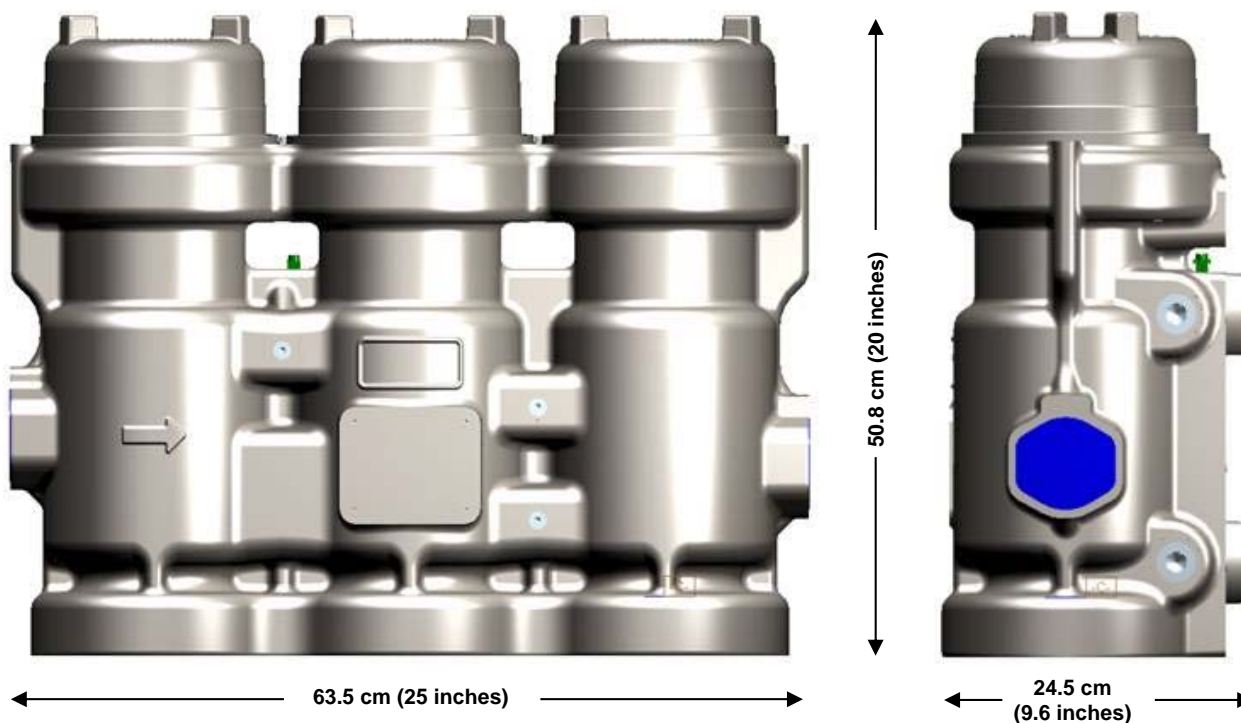

Figure 2. QuickTrip Outline Dimensions

Specifications

Performance

Solenoid Response Time: < 50 milliseconds
 Failsafe Operation: Internal return spring on each solenoid valve

Physical

Trip Block Dimensions: 50.8 x 63.5 x 24.5 cm (20 x 25 x 9.6 inches)
 Solenoid Valves: Rotary
 Failsafe Direction: Open ports
 Local Position Indication: Red & green LEDs viewable via valve sight glass
 Local Power Supply Indication: 2 blue LEDs viewable via valve sight glass
 Weight: 114 kg (252 lb)
 Mounting: Any attitude (8 mounting bolt locations on package rear & bottom)

Environmental

Operating Temperature Range: -40 to +85 °C (-40 to +185 °F)
 Ex nA nC Min Temperature: -20 °C (-4 °F)
 Operating Oil Temperature Range: +15 to +70 °C (+59 to +158 °F)
 Shock: US MIL-STD 202F, Method 213B, Test Cond. J (30 G, 11 ms half sine pulse)
 Vibration: US MIL-STD 810F, M514.5A, Cat. 4 (0.04 G²/Hz, 10–500 Hz, 2 hours/axis, 1.04 Grms)
 Ingress Protection: IP66 per EN 60529

Electrical

Input Supply: 24 Vdc +10% @ 8 A Max (2.6A max / solenoid)
 Discrete Inputs: Isolated (requires 24 Vdc wetting voltage)
 Discrete Outputs Rating: Resistive: 2 A @ 28 Vdc, max 32 Vdc; Inductive: 0.5 A @ 28 Vdc (max 0.2 H)
 Cable Entries: 3x 0.750-14 NPT

Hydraulic

Max Supply Pressure: 34.5 bar (500 psi)
 Oil Flow CV Rating: 10.0
 Fluid Types: Mineral or synthetic or Fyrquel EHC-based oils may be used
 Recommended Oil Cleanliness: 24 to 40 ppm nominal, β75 (ISO 4406 code 20/18/16 Class) max
 Recommended Viscosity: 20 to 100 centistokes
 Fluid Ports: SAE J518 Code 61, 31.8 mm (1.25") diameter

Regulatory Compliance

(Listings are limited only to those units bearing the appropriate Marking or Agency Identification)
 See Manual 26815 for additional information and Special Conditions of Safe Use

European Compliance for CE Marking:

EMC Directive: 2014/30/EU
 ATEX Directive: 2014/34/EU
 Item Prefixes 1, 3: Zone 1, Category 2, Group II G, Ex db IIB T4 Gb
 per SIRA 15ATEX1230X
 Item Prefixes 1, 2, 3, 4: Zone 2, Category 3, Group II G, Ex nA nC IIC T4 Gc
 per SIRA 15ATEX4231X

Other European/International Compliance:

(Compliance with the following European Directives or standards does not qualify this product for application of the CE Marking)

ATEX Directive: Exempt from non-electrical requirements of Directive 2014/34/EU per EN 13463-1
 Machinery Directive: Compliant as a component with 2006/42/EU
 Pressure Equipment Directive: Compliant as "SEP" per Article 4.3 to 2014/68/EC

EAC Customs Union: Certified to Technical Regulation CU 012/2011 for use in potentially explosive atmospheres. Certificate RU C-US.MHO62.B.02276 as 1Ex d IIB T4 Gb X and Ex nA IICT4 Gc X (Item Prefixes 3 and 4)

Other International Compliance:

IECEX: Certified for use in explosive atmospheres per IECEX Certificate IECEX CSA 15.0009X as Ex db IIB T4 Gb (Item Prefixes 1, 3) and Ex nA nC IIC T4 Gc (Item Prefixes 1, 2, 3, 4)

North American Compliance

CSA: CSA Certified for Class I, Div. 1, Groups C & D T4 (Item Prefix 1) and Class I, Div. 2 Groups A, B, C, & D, T4 (Item Prefixes 1, 2) at 85°C ambient. For use in Canada and the United States. Certificate 2757391.

SIL Certification:

SIL-3: Product has been evaluated to IEC 61508 Parts 1-2 and 4-7:2010 as well as IEC 61511 Parts 1-3:2004 (in extracts) and has been found to be suitable for use in a safety instrumented system up to SIL-3.
 TUV Rheinland Certificate V 486.01/15

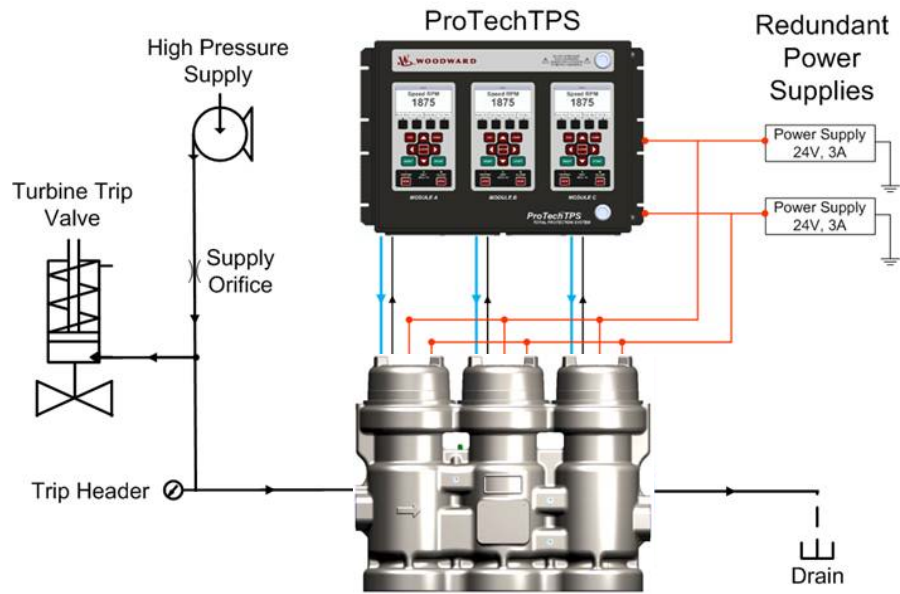

Figure 3. Turbine Safety System Interconnection Diagram

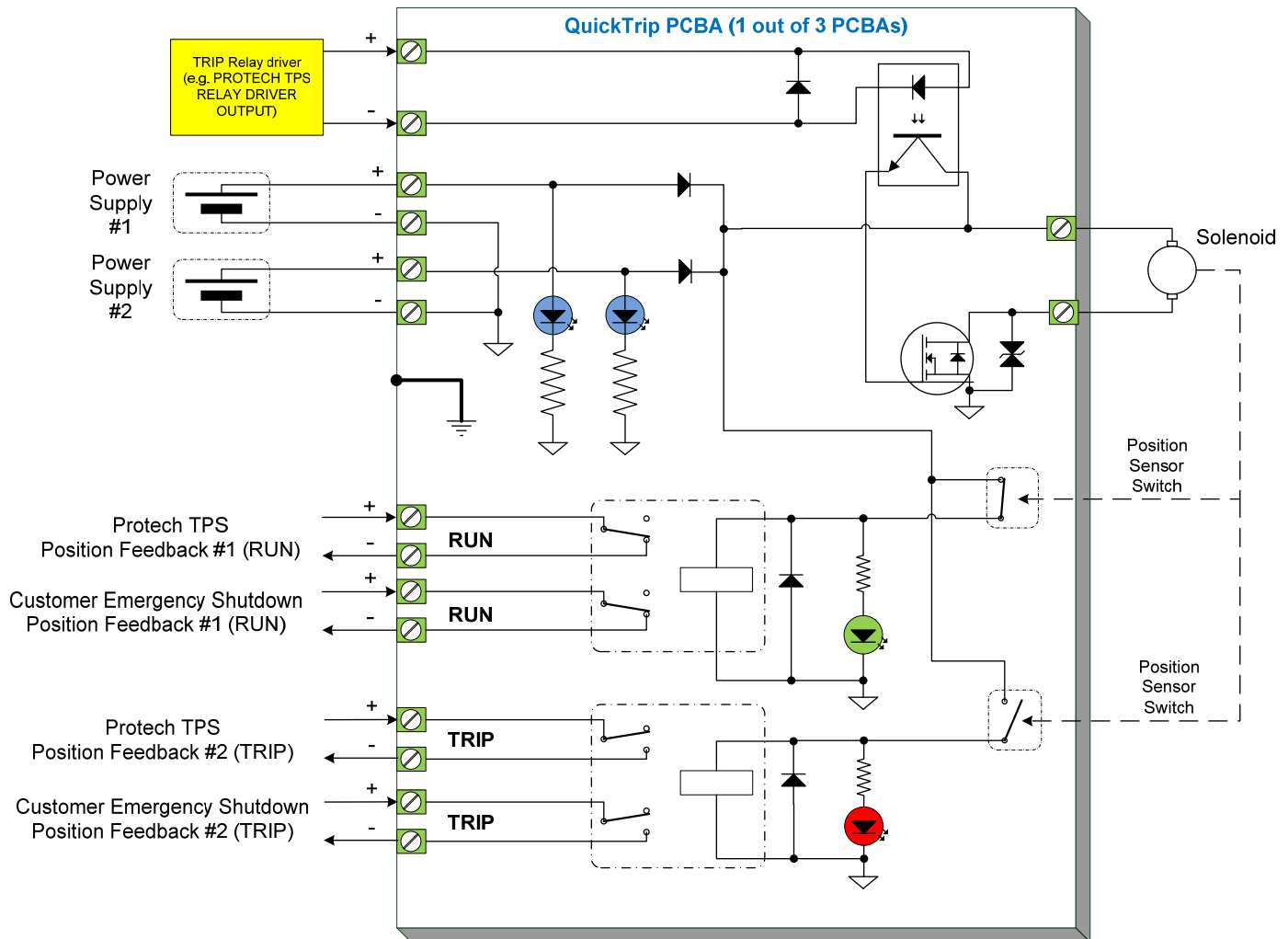

Figure 4. QuickTrip Module Electrical Schematic



PO Box 1519, Fort Collins CO 80522-1519, USA
 1041 Woodward Way, Fort Collins CO 80524, USA
 Phone +1 (970) 482-5811

Email and Website—www.woodward.com

Woodward has company-owned plants, subsidiaries, and branches, as well as authorized distributors and other authorized service and sales facilities throughout the world. Complete address / phone / fax / email information for all locations is available on our website.

This document is distributed for informational purposes only. It is not to be construed as creating or becoming part of any Woodward contractual or warranty obligation unless expressly stated in a written sales contract.

Copyright © Woodward 2013–2018, All Rights Reserved

For more information contact:

