





Product Manual 26188
(Revision Y, 4/2026)
Original Instructions

IGV (Inlet Guide Vane) Actuator
Product

7E / 7F Turbines

Installation and Operation Manual

	<p>Read this entire manual and all other publications pertaining to the work to be performed before installing, operating, or servicing this equipment.</p> <p>Practice all plant and safety instructions and precautions.</p> <p>Failure to follow instructions can cause personal injury and/or property damage.</p>
General Precautions	

	<p>This publication may have been revised or updated since this copy was produced. The latest version of most publications is available on the Woodward website.</p> <p style="text-align: center;">Woodward Industrial Support: Get Help</p> <p>If your publication is not there, please contact your customer service representative to get the latest copy.</p>
Revisions	

	<p>Any unauthorized modifications to or use of this equipment outside its specified mechanical, electrical, or other operating limits may cause personal injury and/or property damage, including damage to the equipment. Any such unauthorized modifications: (i) constitute "misuse" and/or "negligence" within the meaning of the product warranty thereby excluding warranty coverage for any resulting damage, and (ii) invalidate product certifications or listings.</p>
Proper Use	

	<p>If the cover of this publication states "Translation of the Original Instructions" please note:</p> <p>The original source of this publication may have been updated since this translation was made. The latest version of most publications is available on the Woodward website.</p> <p style="text-align: center;">Woodward Industrial Support: Get Help</p> <p>Always compare with the original for technical specifications and for proper and safe installation and operation procedures.</p> <p>If your publication is not on the Woodward website, please contact your customer service representative to get the latest copy.</p>
Translated Publications	

Revisions— A bold, black line alongside the text identifies changes in this publication since the last revision.

Woodward reserves the right to update any portion of this publication at any time. Information provided by Woodward is believed to be correct and reliable. However, no responsibility is assumed by Woodward unless otherwise expressly undertaken.

Contents

WARNINGS AND NOTICES	3
ELECTROSTATIC DISCHARGE AWARENESS	4
REGULATORY COMPLIANCE	5
CHAPTER 1. GENERAL INFORMATION	7
Introduction.....	7
IGV Actuator Functional Characteristics	8
CHAPTER 2. IGV ACTUATOR OPERATION	42
CHAPTER 3. STANDARD COMPONENT DETAILS	43
Triple Coil Electrohydraulic Servo Valve Assembly	43
Trip Relay Valve Assembly	43
Hydraulic Filter Assembly.....	44
LVDT Position Feedback Sensors	44
CHAPTER 4. INSTALLATION	45
General.....	45
Unpacking	45
Hydraulic Connections	46
Electrical Connections.....	47
Electronic Settings	47
Rigging Procedure	48
CHAPTER 5. MAINTENANCE AND HARDWARE REPLACEMENT	49
Maintenance.....	49
Hardware Replacement	49
Troubleshooting Charts.....	52
CHAPTER 6. PRODUCT SUPPORT AND SERVICE OPTIONS	55
Product Support Options.....	55
Product Service Options	55
Returning Equipment for Repair	56
Replacement Parts.....	57
Engineering Services	57
Contacting Woodward's Support Organization.....	57
Technical Assistance	58
REVISION HISTORY	59
DECLARATIONS	60

Illustrations and Tables

Figure 1-1a. IGV Actuator with Hydraulic Trip, Low Pressure Trip Option (left side view)	10
Figure 1-1b. IGV Actuator with Hydraulic Trip, Low Pressure Trip Option (front and top views)	11
Figure 1-1c. IGV Actuator with Hydraulic Trip, Low Pressure Trip Option (right side view)	12
Figure 1-1d. IGV Actuator (partial cutaway with reference numbers).....	13
Figure 1-2a. 7F IGV Actuator with Hydraulic Trip, Low Pressure Trip Option (left side view).....	14
Figure 1-2b. 7F IGV Actuator with Hydraulic Trip, Low Pressure Trip Option (front and top views)	15
Figure 1-2c. 7F IGV Actuator with Hydraulic Trip, Low Pressure Trip Option (right side view).....	16
Figure 1-3a. 7F IGV Actuator with Hydraulic Trip, Low Pressure Trip Option (left side view) [until 30NOV2005].....	17
Figure 1-3b. 7F IGV Actuator with Hydraulic Trip, Low Pressure Trip Option (front and top views) [until 30NOV2005].....	18
Figure 1-3c. 7F IGV Actuator with Hydraulic Trip, Low Pressure Trip Option (right side view) [until 30NOV2005].....	19
Figure 1-4a. 7E IGV Actuator with Hydraulic Trip, Low Pressure Trip Option (left side view) [after 1DEC2005].....	20
Figure 1-4b. 7E IGV Actuator with Hydraulic Trip, Low Pressure Trip Option (front and top views) [after 1DEC2005].....	21
Figure 1-4c. 7E IGV Actuator with Hydraulic Trip, Low Pressure Trip Option (right side view) [after 1DEC2005].....	22
Figure 1-5a. 7F IGV Actuator with Hydraulic Trip, Low Pressure Trip Option (left side view).....	23
Figure 1-5b. 7F IGV Actuator with Hydraulic Trip, Low Pressure Trip Option (front and top views)	24
Figure 1-5c. 7F IGV Actuator with Hydraulic Trip, Low Pressure Trip Option (right side view).....	25
Figure 1-6a. 7F IGV Actuator with Hydraulic Trip, Low Pressure Trip Option, 180 Deg LVDT Orientation (left side view)	26
Figure 1-6b. 7F IGV Actuator with Hydraulic Trip, Low Pressure Trip Option, 180 Deg LVDT Orientation (front and top view).....	27
Figure 1-6c. 7F IGV Actuator with Hydraulic Trip, Low Pressure Trip Option, 180 Deg LVDT Orientation (right side view)	28
Figure 1-7a. 7F IGV Actuator with Hydraulic Trip, High Pressure Trip Option (left side view)	29
Figure 1-7b. 7F IGV Actuator with Hydraulic Trip, High Pressure Trip Option (front and top views)	30
Figure 1-7c. 7F IGV Actuator with Hydraulic Trip, High Pressure Trip Option (right side view)	31
Figure 1-8a. 7F IGV Actuator with Electric Trip (left side view)	32
Figure 1-8b. 7F IGV Actuator with Electric Trip (front and top view)	33
Figure 1-8c. 7F IGV Actuator with Electric Trip (right side view)	34
Figure 1-9a. 7E IGV Actuator with Electric Trip (left side view)	35
Figure 1-9b. 7E IGV Actuator with Electric Trip (front and top view)	36
Figure 1-9c. 7E IGV Actuator with Electric Trip (right side view).....	37
Figure 1-10. IGV Hydraulic Schematic (Hydraulic Trip System).....	38
Figure 1-11. IGV Hydraulic Schematic, High Pressure Trip Option (Hydraulic Trip System).....	38
Figure 1-12. IGV Hydraulic Schematic (Electric Trip System).....	39
Figure 1-13. Servo Valve Electrical Schematic and Wiring Diagram.....	39
Figure 1-14. LVDT Electrical Schematic and Wiring Diagram	40
Figure 1-15. Servo Valve Electrical Schematic and Wiring Diagram (Electric Trip System)	40
Figure 4-1. IGV Actuator Block Diagram.....	47
Table 1-1. IGV Functional Characteristics	8
Table 1-2. IGVs with Hydraulic Trip	9
Table 1-3. IGVs with Electric Trip	32
Table 1-4. IGV Trip Type and Stroke	41
Table 5-1. Turbine Frame, Actuator, and Stroke	52

Warnings and Notices

Important Definitions



This is the safety alert symbol used to alert you to potential personal injury hazards. Obey all safety messages that follow this symbol to avoid possible injury or death.

- **DANGER** - Indicates a hazardous situation, which if not avoided, will result in death or serious injury.
- **WARNING** - Indicates a hazardous situation, which if not avoided, could result in death or serious injury.
- **CAUTION** - Indicates a hazardous situation, which if not avoided, could result in minor or moderate injury.
- **NOTICE** - Indicates a hazard that could result in property damage only (including damage to the control).
- **IMPORTANT** - Designates an operating tip or maintenance suggestion.

WARNING

**Overspeed /
Overtemperature /
Overpressure**

The engine, turbine, or other type of prime mover should be equipped with an overspeed shutdown device to protect against runaway or damage to the prime mover with possible personal injury, loss of life, or property damage.

The overspeed shutdown device must be totally independent of the prime mover control system. An overtemperature or overpressure shutdown device may also be needed for safety, as appropriate.

WARNING

**Personal Protective
Equipment**

The products described in this publication may present risks that could lead to personal injury, loss of life, or property damage. Always wear the appropriate personal protective equipment (PPE) for the job at hand. Equipment that should be considered includes but is not limited to:

- Eye Protection
- Hearing Protection
- Hard Hat
- Gloves
- Safety Boots
- Respirator

Always read the proper Material Safety Data Sheet (MSDS) for any working fluid(s) and comply with recommended safety equipment.

WARNING

Start-up

Be prepared to make an emergency shutdown when starting the engine, turbine, or other type of prime mover, to protect against runaway or overspeed with possible personal injury, loss of life, or property damage.

Electrostatic Discharge Awareness

NOTICE

Electrostatic Precautions

Electronic controls contain static-sensitive parts. Observe the following precautions to prevent damage to these parts:

- Discharge body static before handling the control (with power to the control turned off, contact a grounded surface and maintain contact while handling the control).
- Avoid all plastic, vinyl, and Styrofoam (except antistatic versions) around printed circuit boards.
- Do not touch the components or conductors on a printed circuit board with your hands or with conductive devices.

To prevent damage to electronic components caused by improper handling, read and observe the precautions in Woodward manual **82715**, *Guide for Handling and Protection of Electronic Controls, Printed Circuit Boards, and Modules*.

Follow these precautions when working with or near the control.

1. Avoid the build-up of static electricity on your body by not wearing clothing made of synthetic materials. Wear cotton or cotton-blend materials as much as possible because these do not store static electric charges as much as synthetics.
2. Do not remove the printed circuit board (PCB) from the control cabinet unless absolutely necessary. If you must remove the PCB from the control cabinet, follow these precautions:
 - Do not touch any part of the PCB except the edges.
 - Do not touch the electrical conductors, the connectors, or the components with conductive devices or with your hands.
 - When replacing a PCB, keep the new PCB in the plastic antistatic protective bag it comes in until you are ready to install it. Immediately after removing the old PCB from the control cabinet, place it in the antistatic protective bag.

Regulatory Compliance

European Compliance for CE Marking

These listings are limited only to those units bearing the CE Marking.

ATEX Directive: Directive 2014/34/EU on the harmonisation of the laws of the Member States relating to equipment and protective systems intended for use in potentially explosive atmospheres
Zone 2, Category 3, Group II G, Ex nA IIC T3 Gc X

Other European Compliance:

Compliance with the following European Directives or standards does not qualify this product for application of the CE Marking:

RoHS Directive: Restriction of Hazardous Substances 2011/65/EU:
Woodward Turbomachinery Systems products are intended exclusively for sale and use only as a part of Large Scale Fixed Installations per the meaning of Art.2.4(e) of directive 2011/65/EU. This fulfills the requirements stated in Art.2.4(c) and as such the product is excluded from the scope of RoHS2.

EMC Directive: Not applicable to this product. Electromagnetic, EMC, passive devices are excluded from the scope of the 2014/30/EU Directive.

ATEX Directive: Exempt from the non-electrical portion of the ATEX Directive 2014/34/EU due to no potential ignition sources per EN ISO 80079-36:2016 for Zone 2 installation.

Machinery Directive: Compliant as partly completed machinery with Directive 2006/42/EC of the European Parliament and the Council of 17 May 2006 on machinery.

Pressure Equipment Directive: Compliant as "SEP" per Article 4.3 to Pressure Equipment Directive 2014/68/EU on the harmonisation of the laws of the Member States relating to the making available on the market of pressure equipment.

Other International Compliance:

IECEX: For IECEX Marked Valves:
Certified for use in explosive atmospheres per Certificate: IECEX ETL 25.0031X

North American Compliance:

Suitability for use in North American Hazardous Locations is the result of compliance of the individual components:

Servo Valve: FM Certified for Class I, Division 2, Groups A, B, C, & D, per 4B9A6.AX, for use in the United States.

Certified by CSA for use in Canadian Class I, Division 2, Groups A, B, C, D as a component for use in other equipment subject to acceptance by CSA or inspection authority having jurisdiction, per CSA 1072373.

LVDT: ETL Certified for Class I, Division 2, Groups A, B, C, & D, per J98036083-003.

For use in the United States and Canada.

Trip Solenoid: ETL Certified for Class I, Division 2, Groups A, B, C, D per 3168365CRT-004 for use in the United States and Canada.

Special Conditions for Safe Use

Compliance with the Machinery Directive 2006/42/EC noise measurement and mitigation requirements is the responsibility of the manufacturer of the machinery into which this product is incorporated.

Wiring must be in accordance with North American Class I, Division 2 or European or other international Zone 2 Category 3 wiring methods as applicable, and in accordance with the authority having jurisdiction.

Field Wiring must be suitable for at least 121 Degrees C.

The risk of electrostatic discharge is reduced by permanent installation of the actuator, proper connection of the equipotential ground lugs, and care when cleaning. This device must not be cleaned or wiped off/against unless the area is known to be non-hazardous.

For IECEx Marked Valves

1. User must use wires rated for temperature greater than 150°C to connect to solenoids.



EXPLOSION HAZARD—Do not connect or disconnect while circuit is live unless area is known to be non-hazardous.

Substitution of components may impair suitability for Class I, Division 2 or Zone 2 applications.



RISQUE D'EXPLOSION—Ne pas raccorder ni débrancher tant que l'installation est sous tension, sauf en cas l'ambiance est décidément non dangereuse.

La substitution de composants peut rendre ce matériel inacceptable pour les emplacements de Classe I, Division 2 ou Zone 2.

Chapter 1.

General Information

Introduction

The IGV (Inlet Guide Vane) actuator controls the position of the inlet guide vanes of the GE Frame 7 industrial gas turbine system. The actuator provides highly accurate position control. The actuator is a double-acting design that will close the guide vane on loss of electrical or hydraulic signals. An on board hydraulic filter is designed into the manifold to augment the reliability of the servo valve and actuator. The servo valve is an electrically redundant triple-coil design. An ac-powered LVDT provides feedback for the actuator.

The Woodward IGV actuator (Figures 1-1 through 1-8) performs a dual function for industrial or utility gas turbines. One function rapidly closes the turbine inlet guide vane. The other function provides accurate position control of the turbine inlet guide vanes.

The IGV actuator features a modular design, and meets critical control characteristics, while allowing the same actuator design to accommodate a variety of stroke, force output, and mechanical interface arrangements. The electrical and mechanical interfaces have been designed for quick and easy assembly or removal of the actuator, at the factory or in the field. The components include an on-board hydraulic filter, electrohydraulic servo valve, trip valves, double-acting hydraulic cylinder, and dual LVDTs.

Optimum control of the inlet guide vane requires that the actuator accurately and quickly track the demand signals transmitted by the control. The IGV actuator has been designed to provide output forces that exceed the opening and closing requirements. The additional margin helps ensure that the system moves rapidly even under service conditions where the actuator has been contaminated or worn. The hydraulic trip relay valves have been selected to provide high operating force margins, and to ensure the desired closure rate of the actuator under trip conditions.

IGV Actuator Functional Characteristics

Table 1-1. IGV Functional Characteristics

Functional Requirement	IGV Actuator		
Position Accuracy	±1% full scale (over ±25 °F/±14 °C deviation from calibration)		
Position Repeatability	±0.5% of point over the range of 10 to 100%		
Hydraulic Fluid Type	Petroleum-based hydraulic fluids as well as fire resistant hydraulic fluids such as Fyrquel EHC		
Maximum Operating Hydraulic Supply Pressure	1400 to 1800 psig (9653 to 12 411 kPa) (design at 1600 psig/11 032 kPa)		
Proof Test Fluid Pressure Level	2700 psig (18 616 kPa) minimum per SAE J214 (Prod Test)		
Minimum Burst Fluid Pressure	4500 psig (31 264 kPa) minimum per SAE J214		
Fluid Filtration Required	10–15 µm at 75 Beta		
Hydraulic Fluid Contamination Level	Per ISO 4406 code 18/16/13 max, code 16/14/11 preferred		
Hydraulic Fluid Temperature	+50 to +160 °F (+10 to +71 °C)		
Actuator Ambient Temperature	–40 to +250 °F (–40 to +121 °C)		
Vibration Test Level	0.5 gp 5–100 Hz sine wave Random 0.01500 gr ² /Hz from 10 to 40 Hz ramping down to 0.00015 gr ² /Hz at 500 Hz		
Shock	Limited to 30 G by servo valve		
Trip Time	From 1 to 5 seconds at 1600 psi (11 032 kPa) supply pressure, 100 °F (38 °C) oil temperature and 3000–5000 lbf (13–22 kN) load (100–0% stroke)		
Slew Time		0% to 100%	100% to 0%
	Actuator	Time Limit	Time Limit
		seconds	seconds
	9904-533	4.5 ±1.5	5.0 ±1.5
	9904-1371	4.5 ±1.5	5.0 ±1.5
	9904-989	4.5 ±1.5	5.0 ±1.5
	9904-1448	4.5 ±1.5	5.0 ±1.5
	9904-3181	4.5 ±1.5	5.0 ±1.5
9904-1532	5.0 ±1.5	5.0 ±1.5	
Trip Pressure (relative to hydraulic return)	Pick up and drop out pressures to be ≤30 psid (207 kPa)		
Hydraulic Fluid Connections for 7F Turbine	Trip Relay Pressure—0.500 SAE Code 61 flange port (-8) Supply Pressure—0.750 SAE Code 61 flange port (-12) Return Port—1.250 SAE Code 61 flange port (-20)		
Hydraulic Fluid Connections for 7E Turbine	Trip Relay Pressure—0.500 SAE O-ring straight thread (-8) Supply Pressure—0.750 SAE O-ring straight thread (-12) Return Port—1.000 NPT port (-16)		
Servo Input Current Rating	–7.2 to +8.8 mA (null bias 0.8 ±0.32 mA)		
Paint	Two part Epoxy		
Actuation Forces (opening and closing at 1600 psig/11 032 kPa)	Retract Force (open)—41 233 lb/183 404 N Extend Force—49 087 lb/218 339 N		
Design Availability Objective	Better than 99.5% over an 8760 hour period		

Table 1-2. IGVs with Hydraulic Trip

ACTUATOR	STROKE LENGTH	STROKE TOLERANCE	RETRACTED/OPEN	IGV OPEN	IGV CLOSED	IGV O.A.L
	inches	inches	inches (mm)	inches (mm)	inches (mm)	inches (mm)
9904-533	2.73	±0.020	32.125 (815.96) 31.875 (809.61)	55.36 (1406.14)	58.090 (1475.47)	59.840 (1519.92)
9904-1371	2.83	±0.020	32.025 (813.44) 31.775 (807.09)	55.260 (1403.6)	58.090 (1475.47)	59.840 (1519.92)
9904-989	1.880	±0.020	29.850 (758.18)	49.850 (1266.18)	51.730 (1313.93)	53.480 (1358.38)
9904-1448	3.003	±0.020	31.852 (809.04) 31.602 (802.69)	55.317 (1405.05)	58.320 (1481.33)	60.070 (1525.79)
9904-3181	3.003	±0.020	31.852 (809.04) 31.602 (802.69)	55.317 (1405.05)	58.320 (1481.33)	60.070 (1525.79)
9904-1532	3.003	±0.020	31.852 (809.04) 31.602 (802.69)	55.317 (1405.05)	58.320 (1481.33)	60.070 (1525.79)

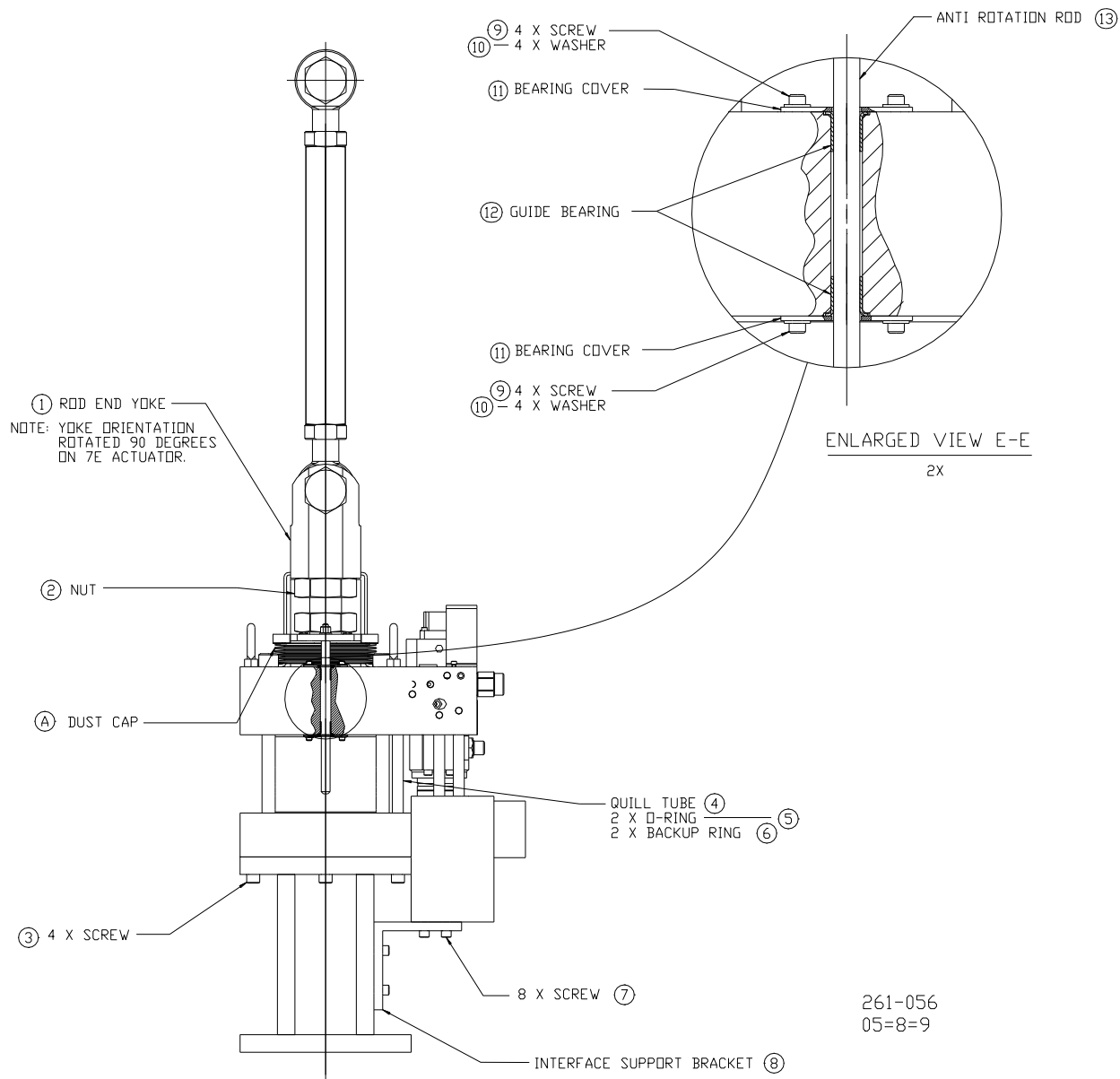

Figure 1-1a. IGV Actuator with Hydraulic Trip, Low Pressure Trip Option (left side view)

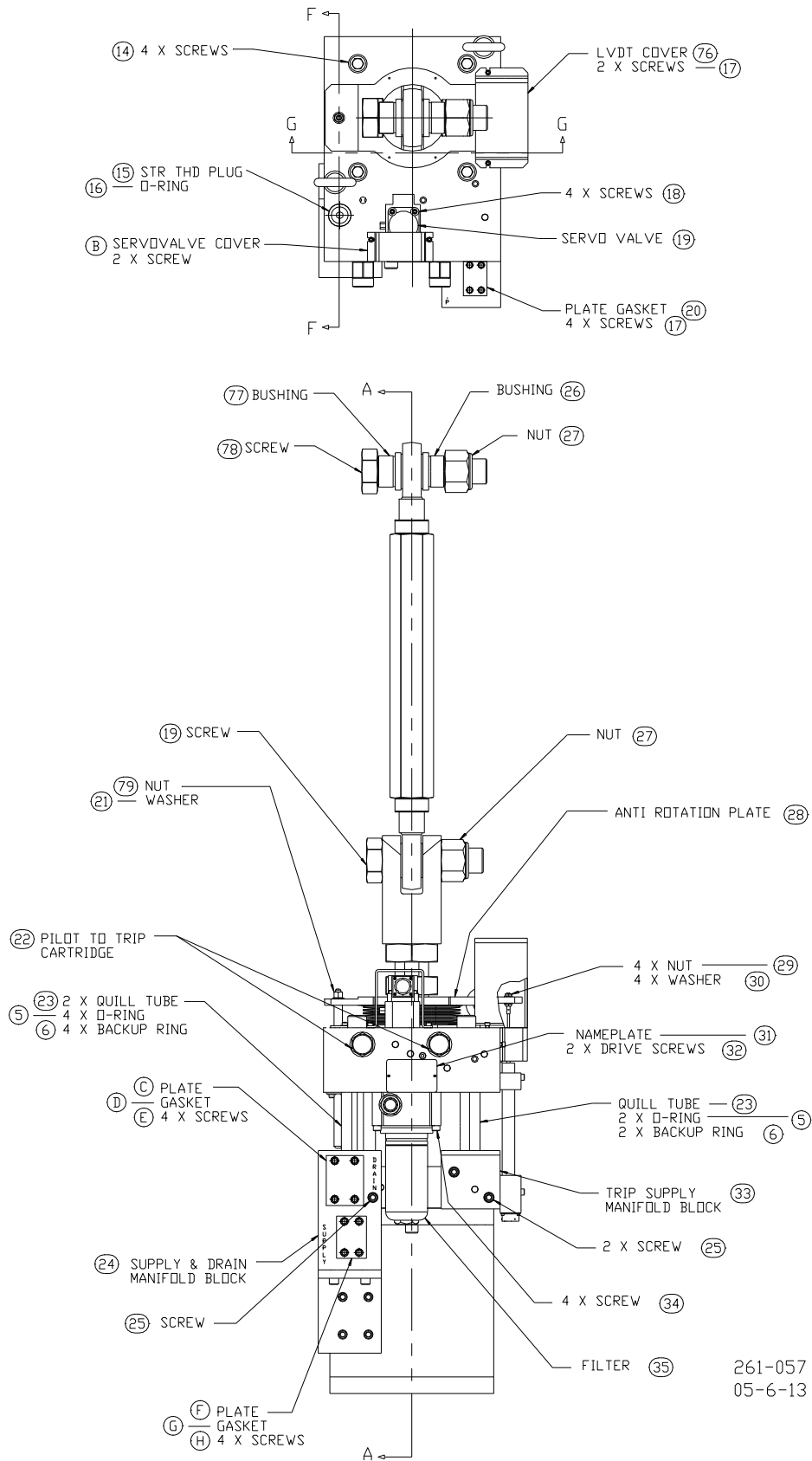
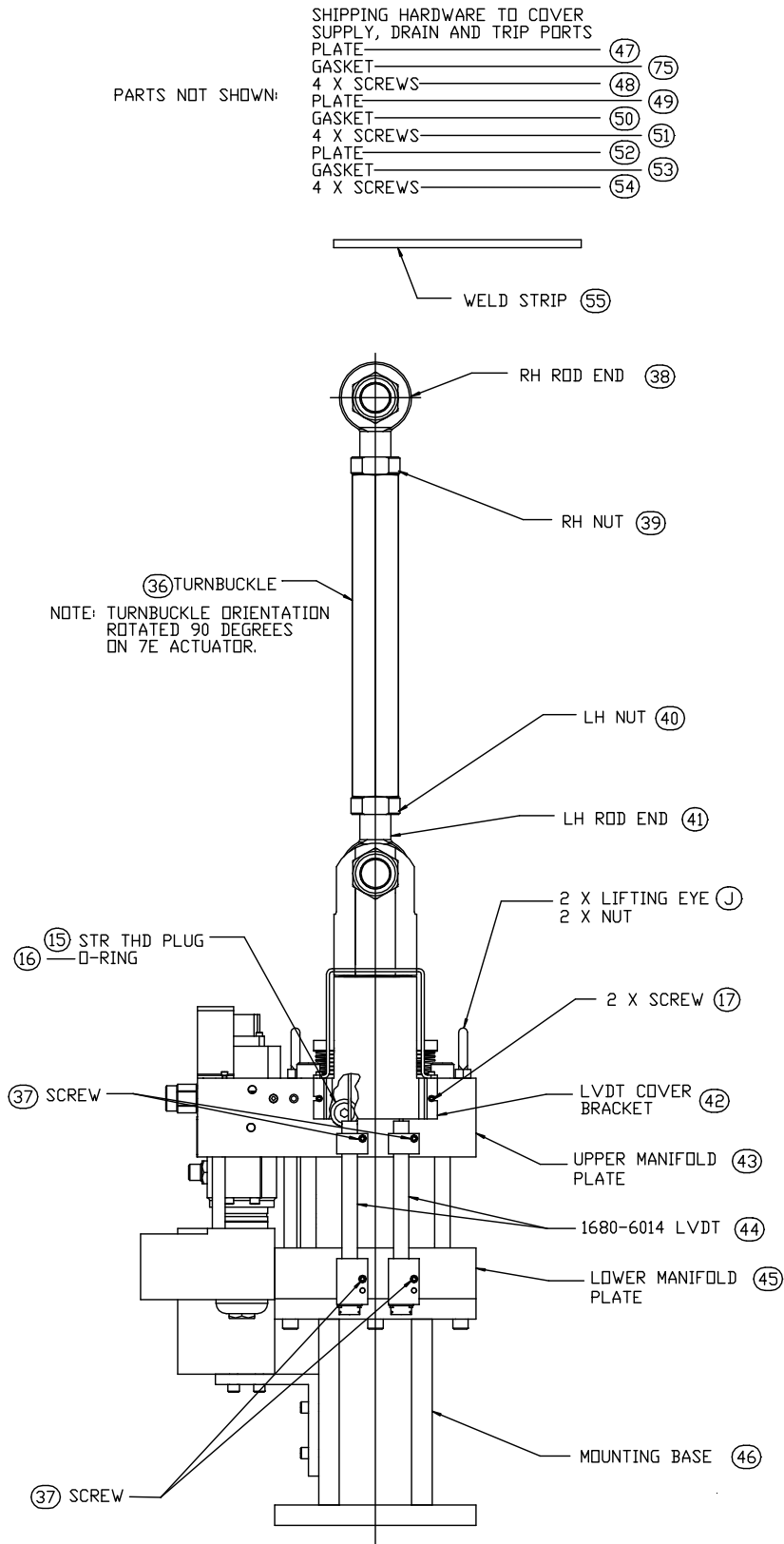

Figure 1-1b. IGV Actuator with Hydraulic Trip, Low Pressure Trip Option (front and top views)



261-058
05-8-9

Figure 1-1c. IGV Actuator with Hydraulic Trip, Low Pressure Trip Option (right side view)

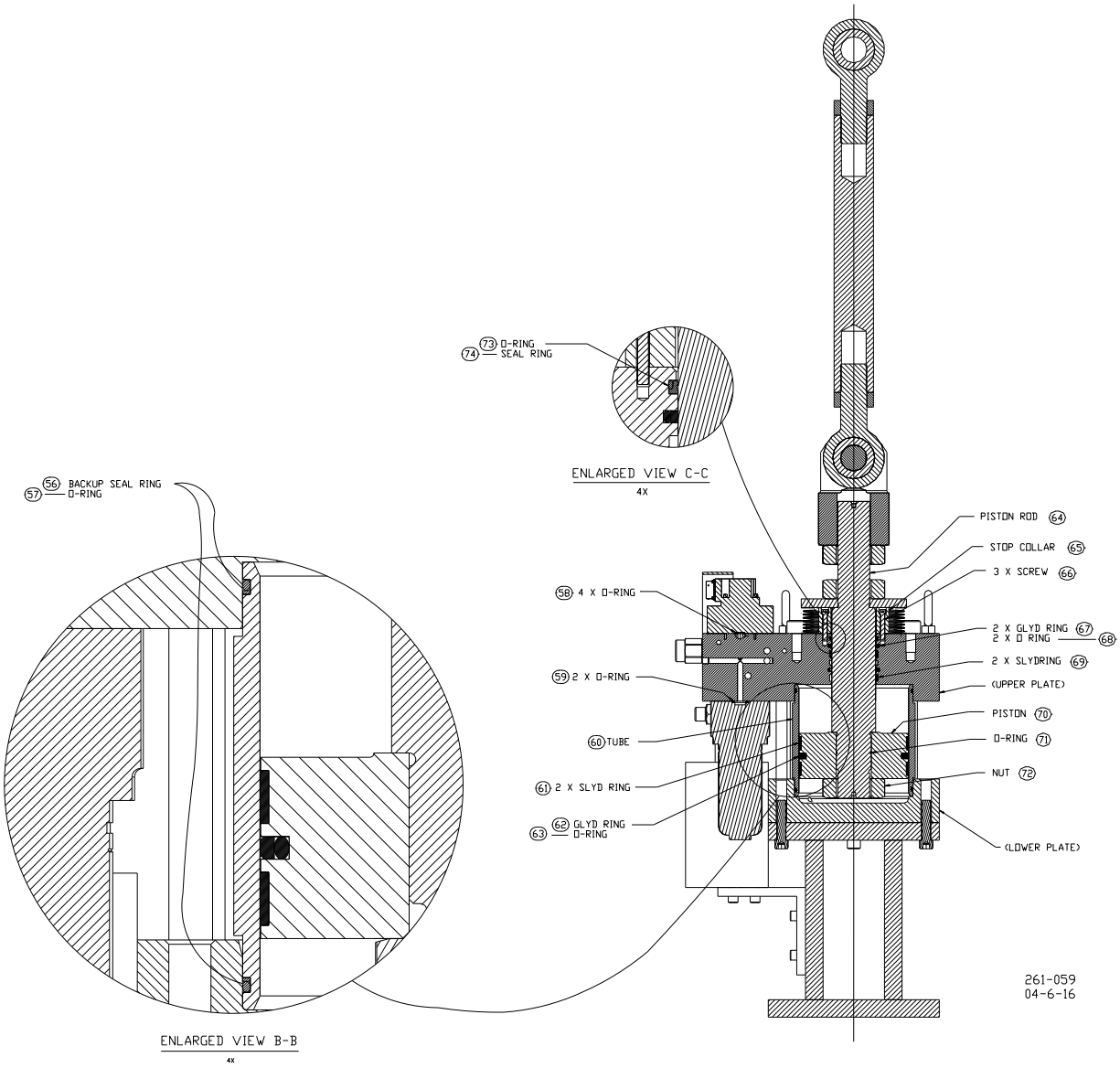

Figure 1-1d. IGV Actuator (partial cutaway with reference numbers)
(Electric trip solenoid not shown—number 1734-1033)

WHEN WELDING - DO NOT USE
ELECTRICAL COMPONENTS AS
WELDING GROUND

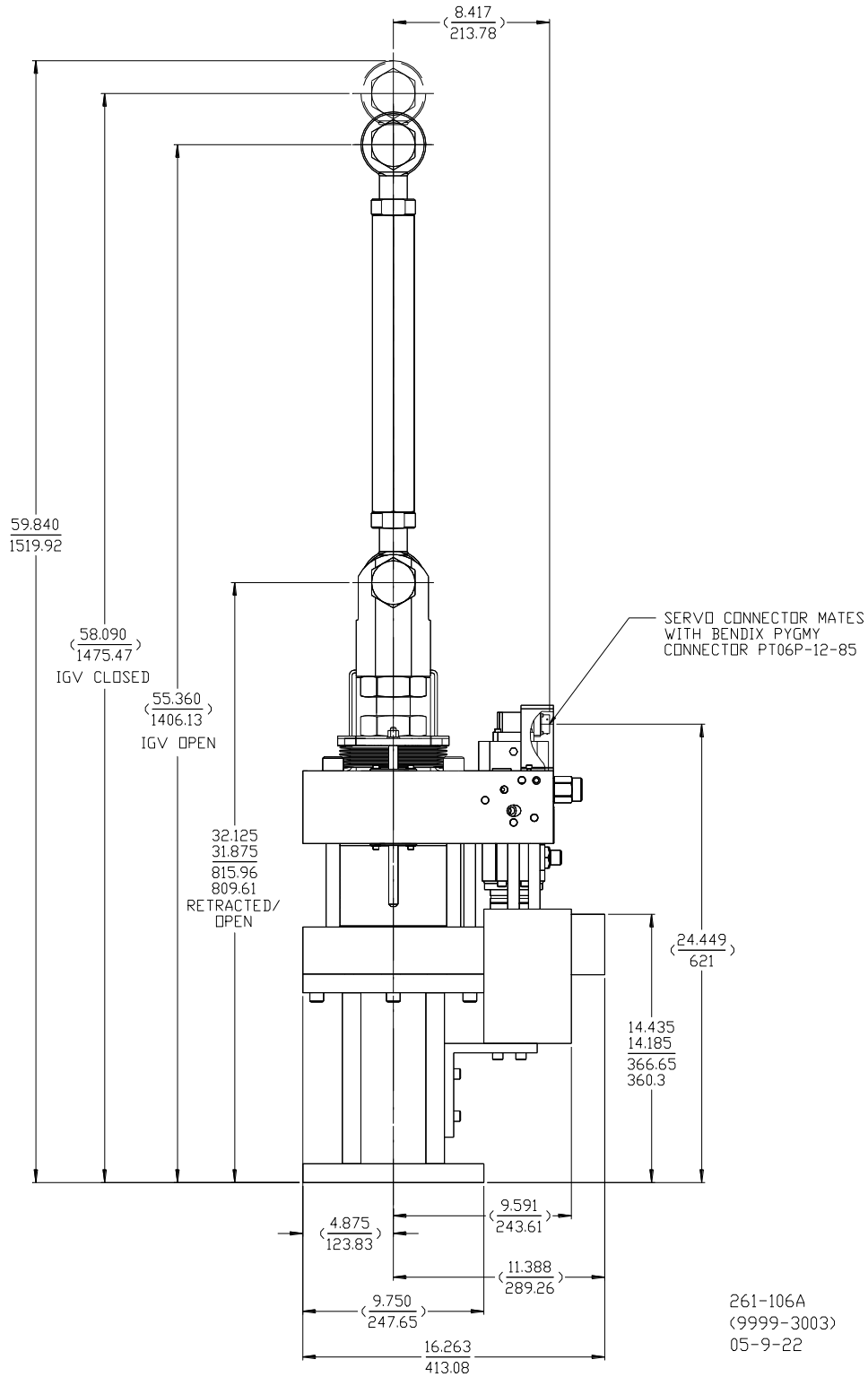

Figure 1-2a. 7F IGV Actuator with Hydraulic Trip, Low Pressure Trip Option (left side view)

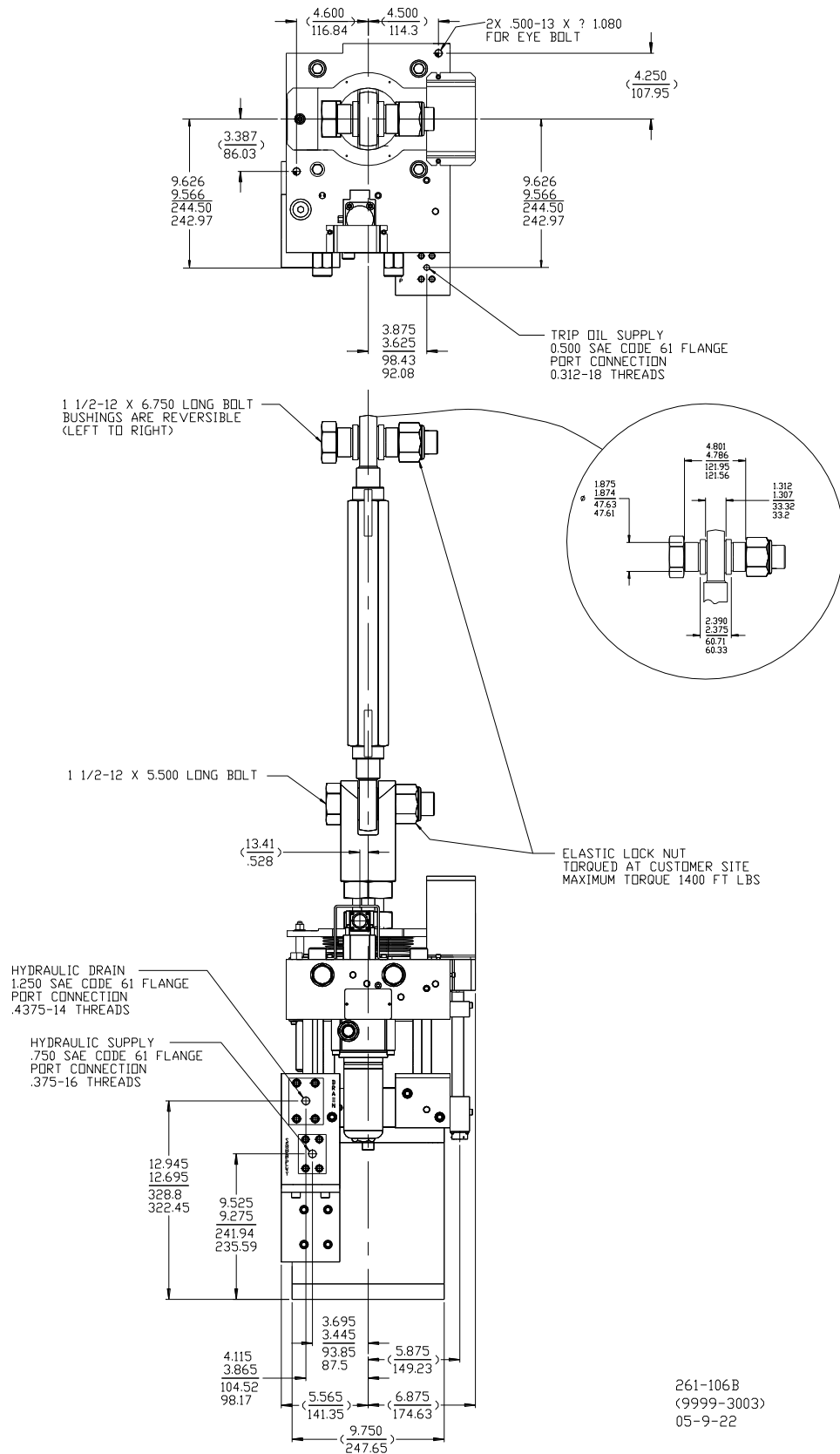

Figure 1-2b. 7F IGV Actuator with Hydraulic Trip, Low Pressure Trip Option (front and top views)

APPROXIMATE WEIGHT 487 LBS

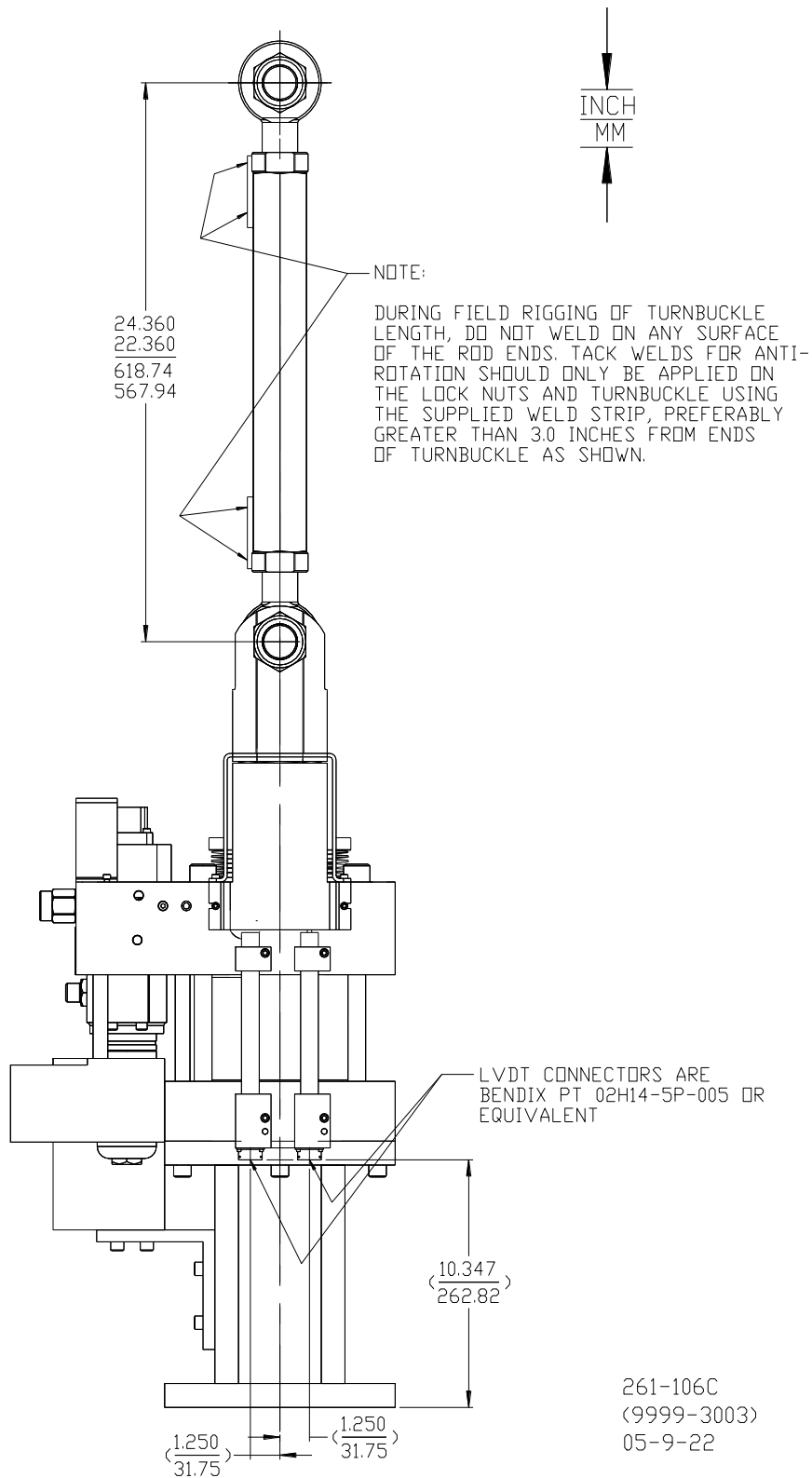

Figure 1-2c. 7F IGV Actuator with Hydraulic Trip, Low Pressure Trip Option (right side view)

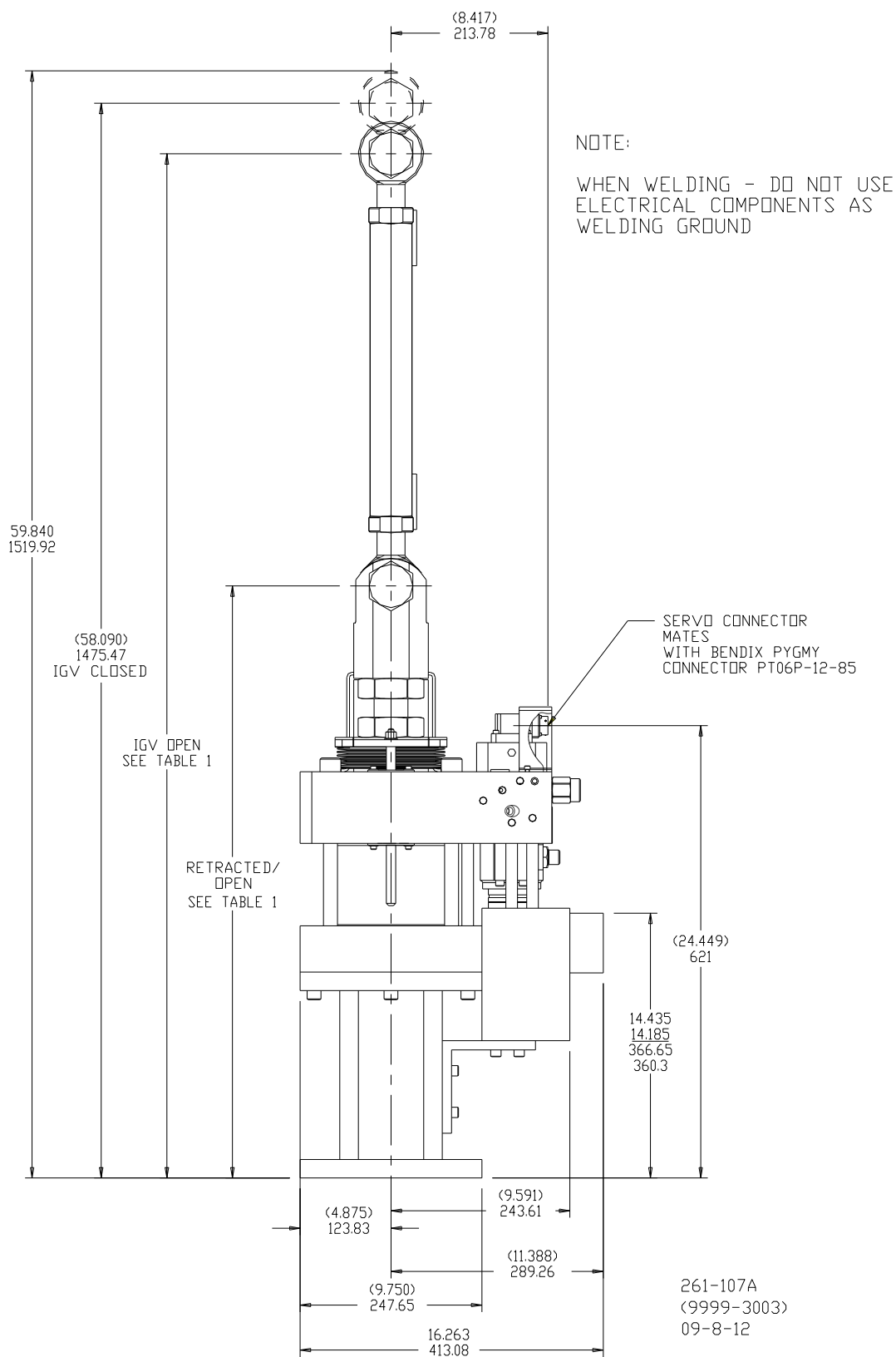

Figure 1-3a. 7F IGV Actuator with Hydraulic Trip, Low Pressure Trip Option
(left side view) [until 30NOV2005]

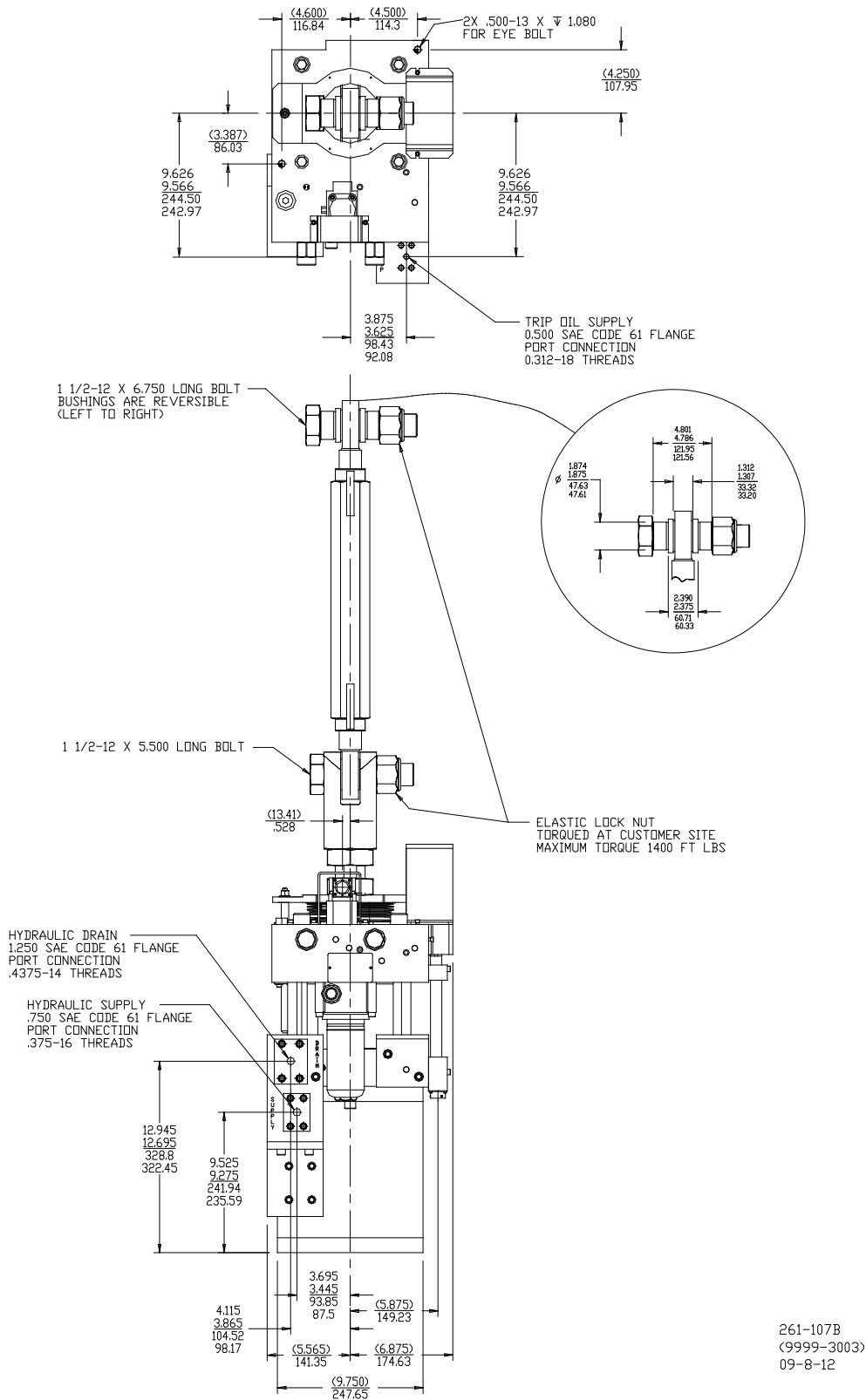

Figure 1-3b. 7F IGV Actuator with Hydraulic Trip, Low Pressure Trip Option (front and top views) [until 30NOV2005]

TABLE 1

P/N	RETRACTED/ OPEN	IGV OPEN REF DIM	GE SPECIFICATION
9904-533	32.125 (815.96) 31.875 (809.61)	55.360 (1406.14)	362A1097P0120 372A4457P011
9904-1371	32.025 (813.44) 31.775 (807.09)	55.260 (1403.60)	372A4457P021

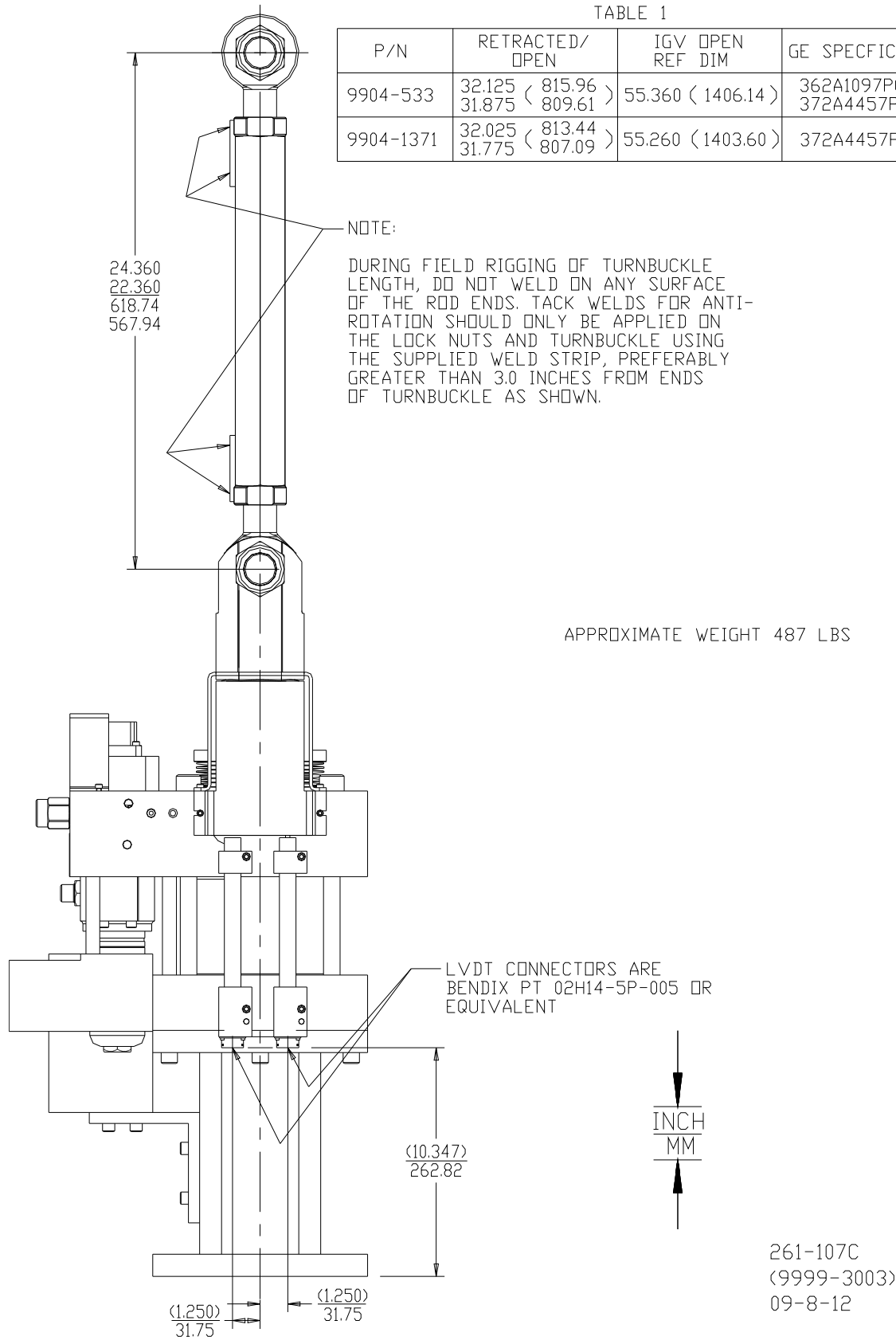

Figure 1-3c. 7F IGV Actuator with Hydraulic Trip, Low Pressure Trip Option (right side view) [until 30NOV2005]

NOTES:

1. WHEN WELDING - DO NOT USE ELECTRICAL COMPONENTS AS WELDING GROUND.
2. APPROXIMATE WEIGHT 500 LBS.
3. THIS IS AN INSTALLATION DRAWING OF 9904-989.

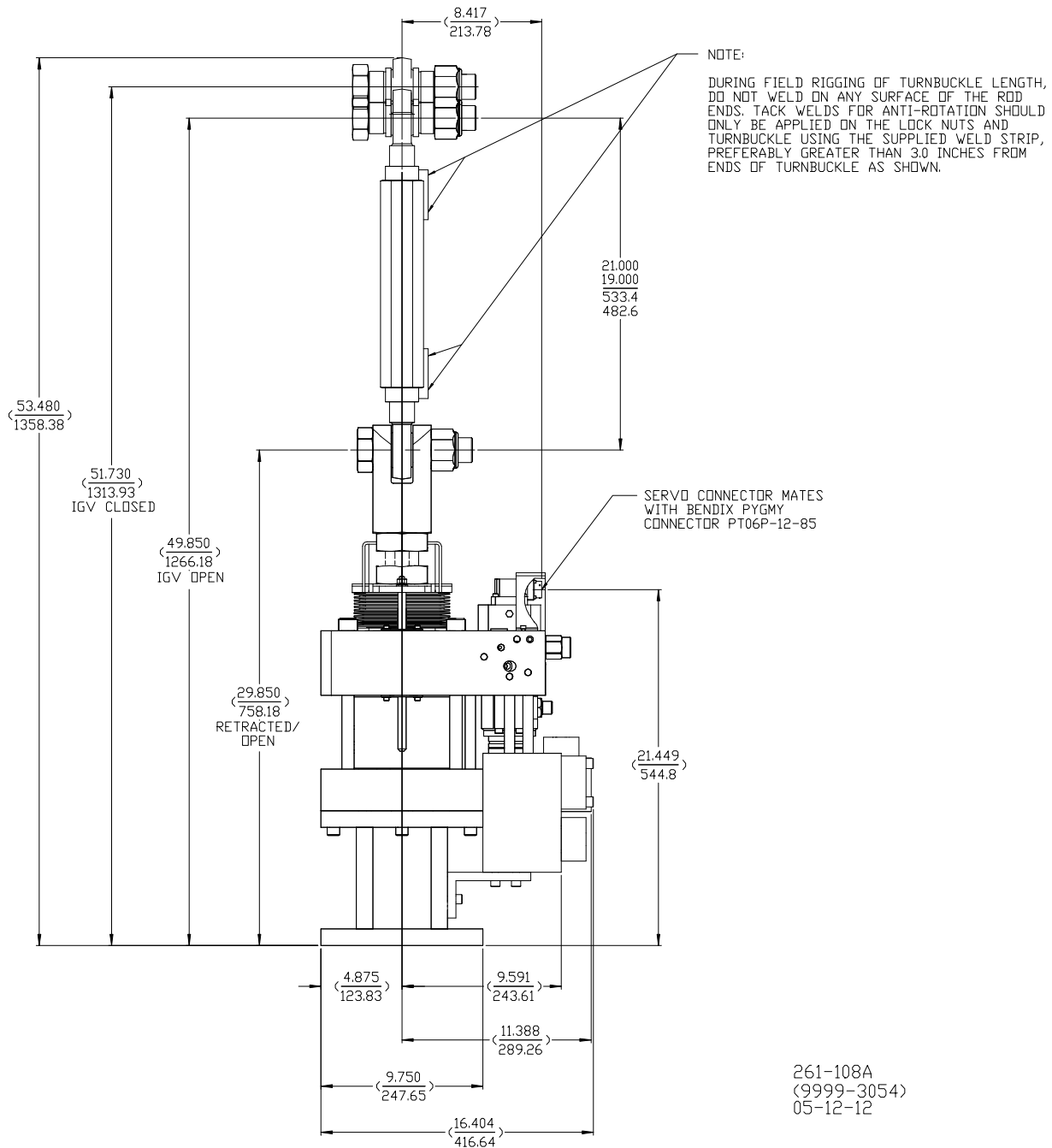

Figure 1-4a. 7E IGV Actuator with Hydraulic Trip, Low Pressure Trip Option (left side view) [after 1DEC2005]

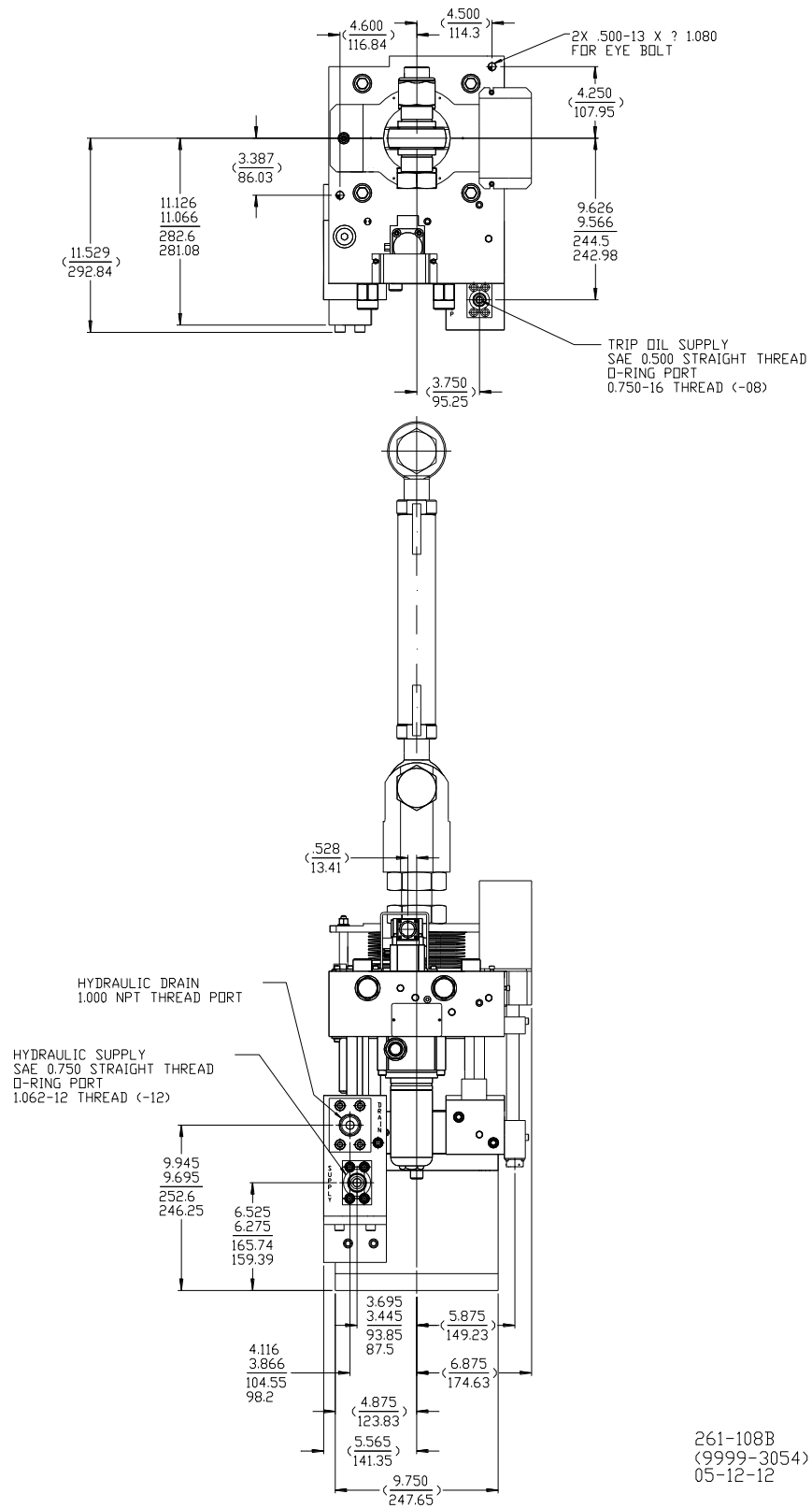

Figure 1-4b. 7E IGV Actuator with Hydraulic Trip, Low Pressure Trip Option (front and top views) [after 1DEC2005]

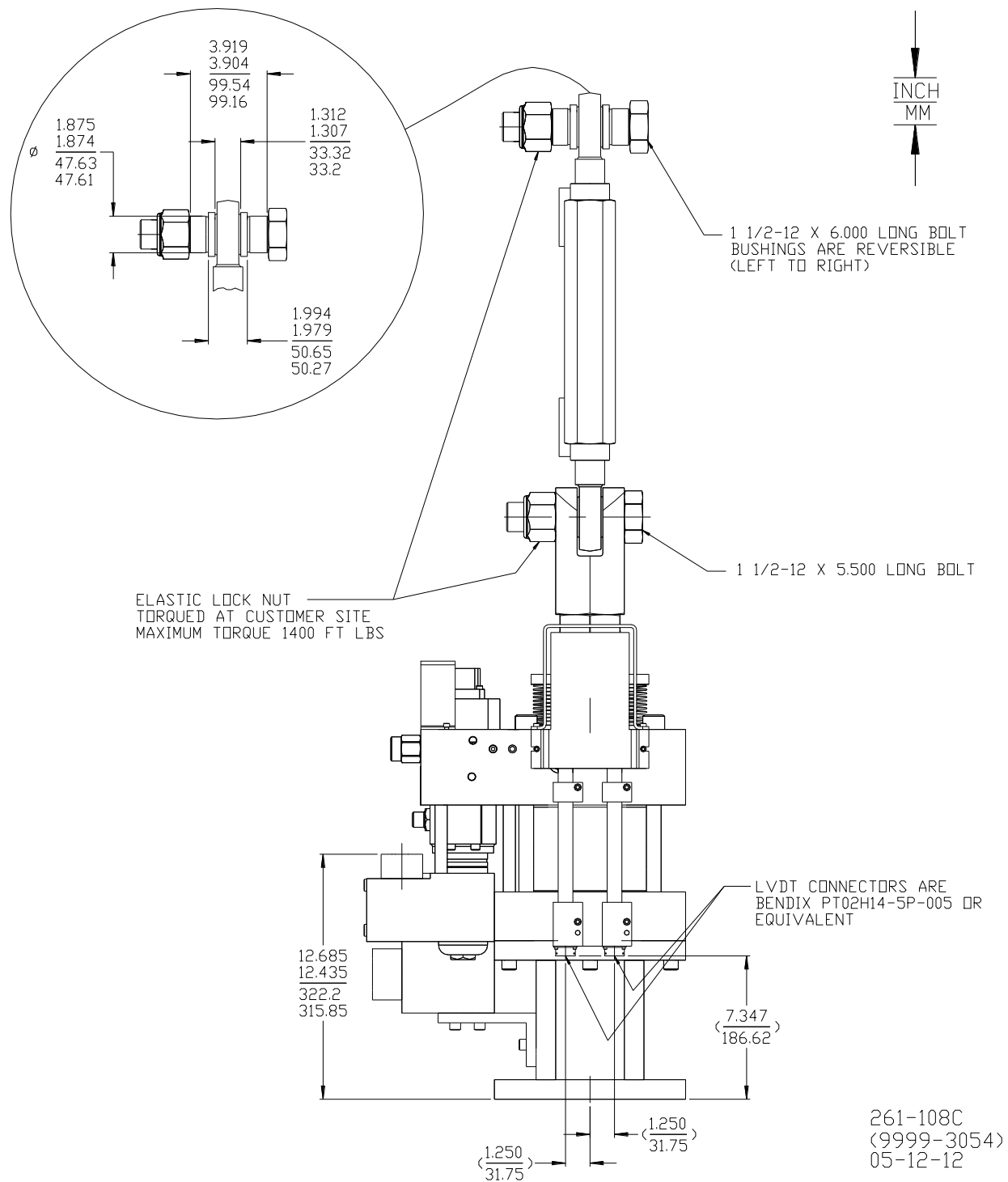

Figure 1-4c. 7E IGV Actuator with Hydraulic Trip, Low Pressure Trip Option (right side view) [after 1DEC2005]

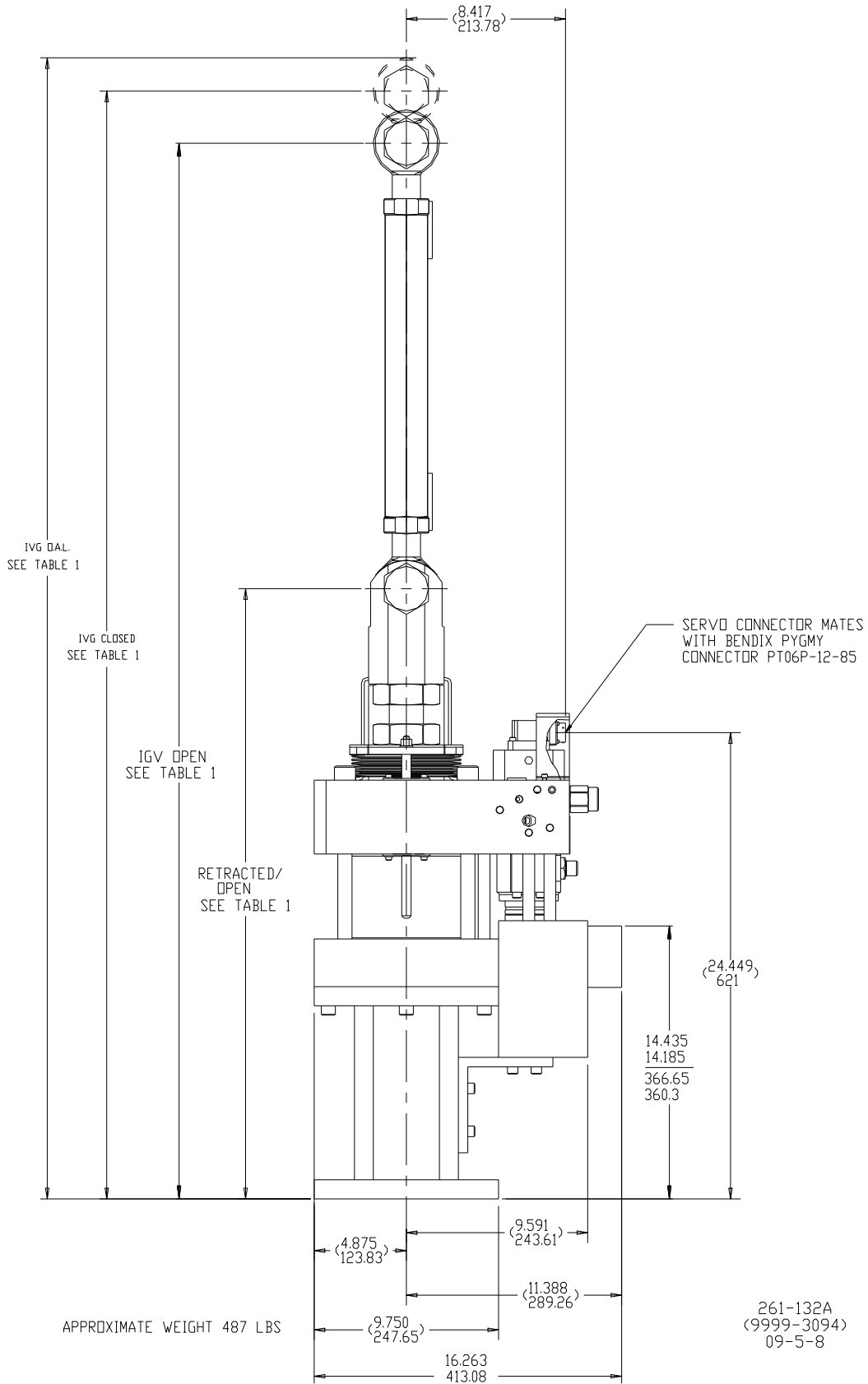

Figure 1-5a. 7F IGV Actuator with Hydraulic Trip, Low Pressure Trip Option (left side view)

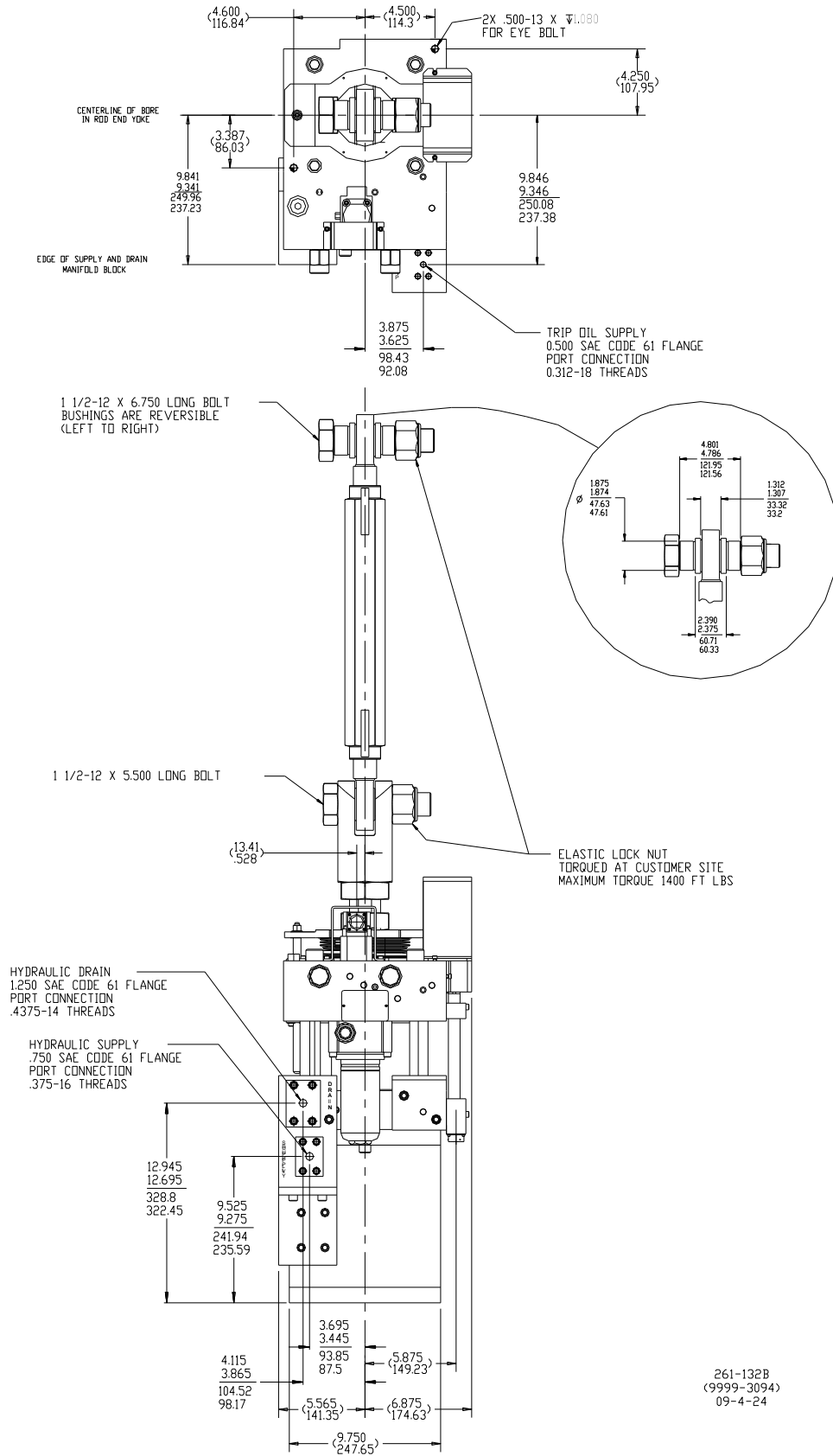

Figure 1-5b. 7F IGV Actuator with Hydraulic Trip, Low Pressure Trip Option (front and top views)

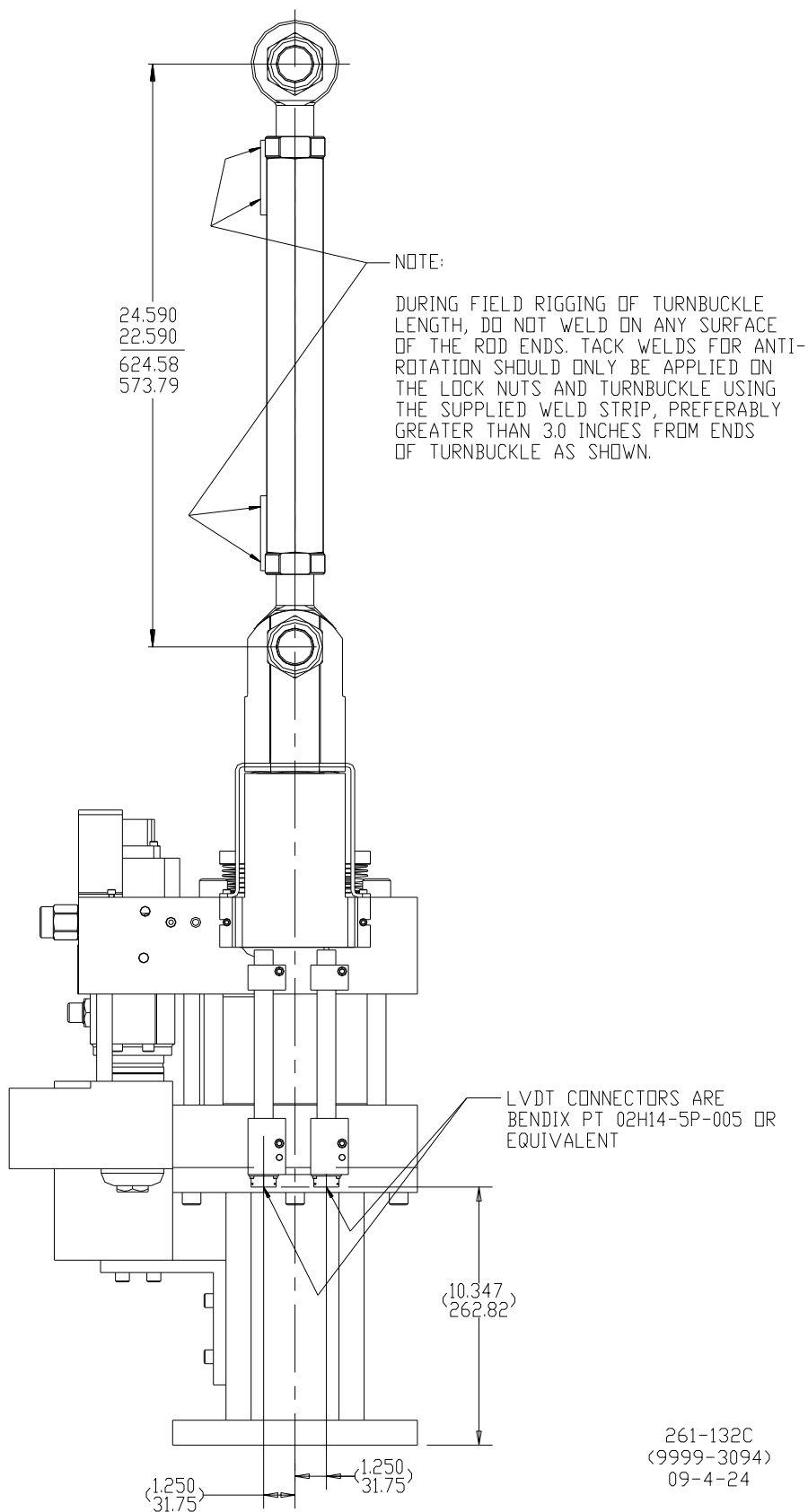

Figure 1-5c. 7F IGV Actuator with Hydraulic Trip, Low Pressure Trip Option (right side view)



Figure 1-6a. 7F IGV Actuator with Hydraulic Trip, Low Pressure Trip Option, 180 Deg LVDT Orientation (left side view)

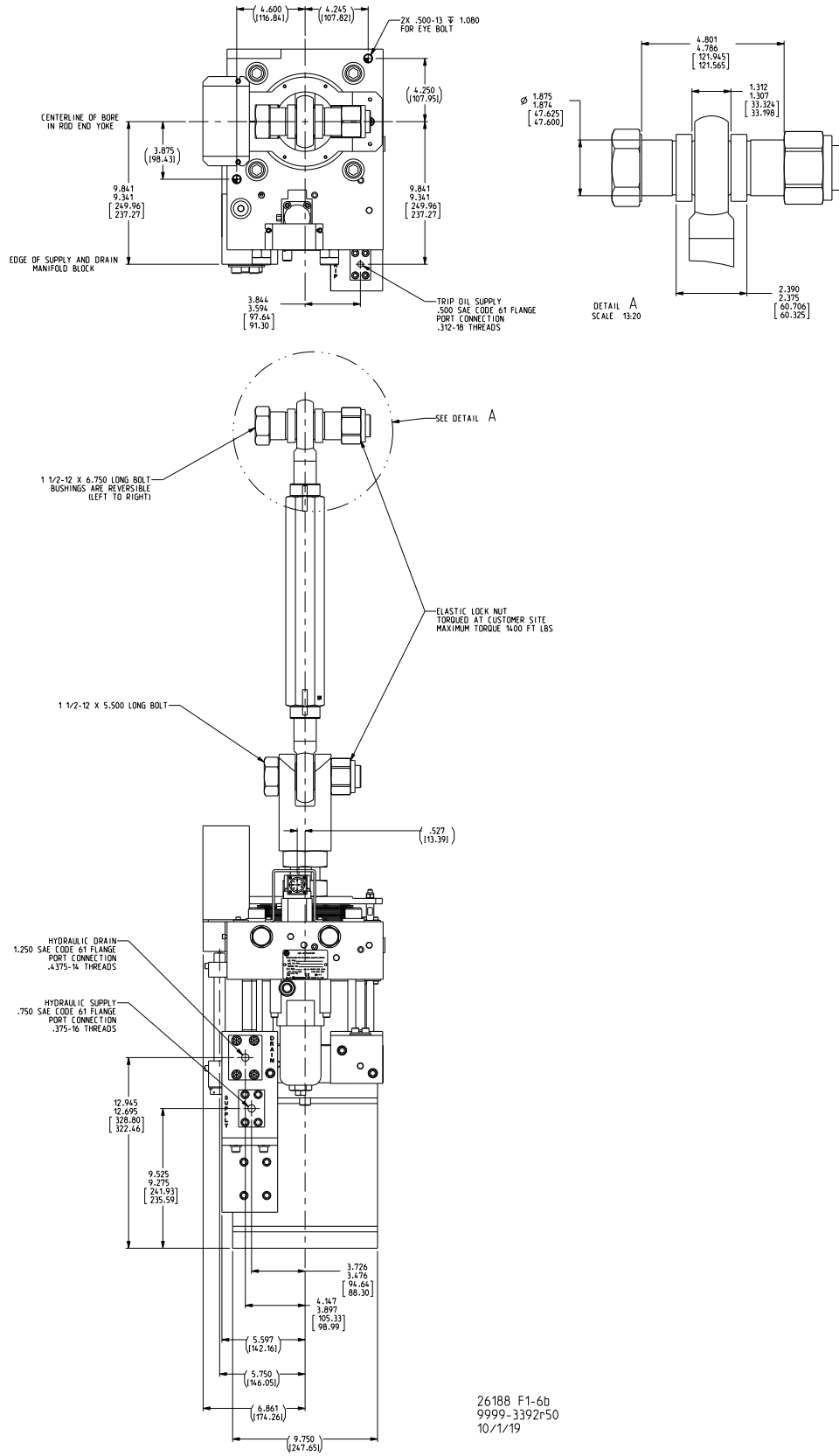

Figure 1-6b. 7F IGV Actuator with Hydraulic Trip, Low Pressure Trip Option, 180 Deg LVDT Orientation (front and top view)

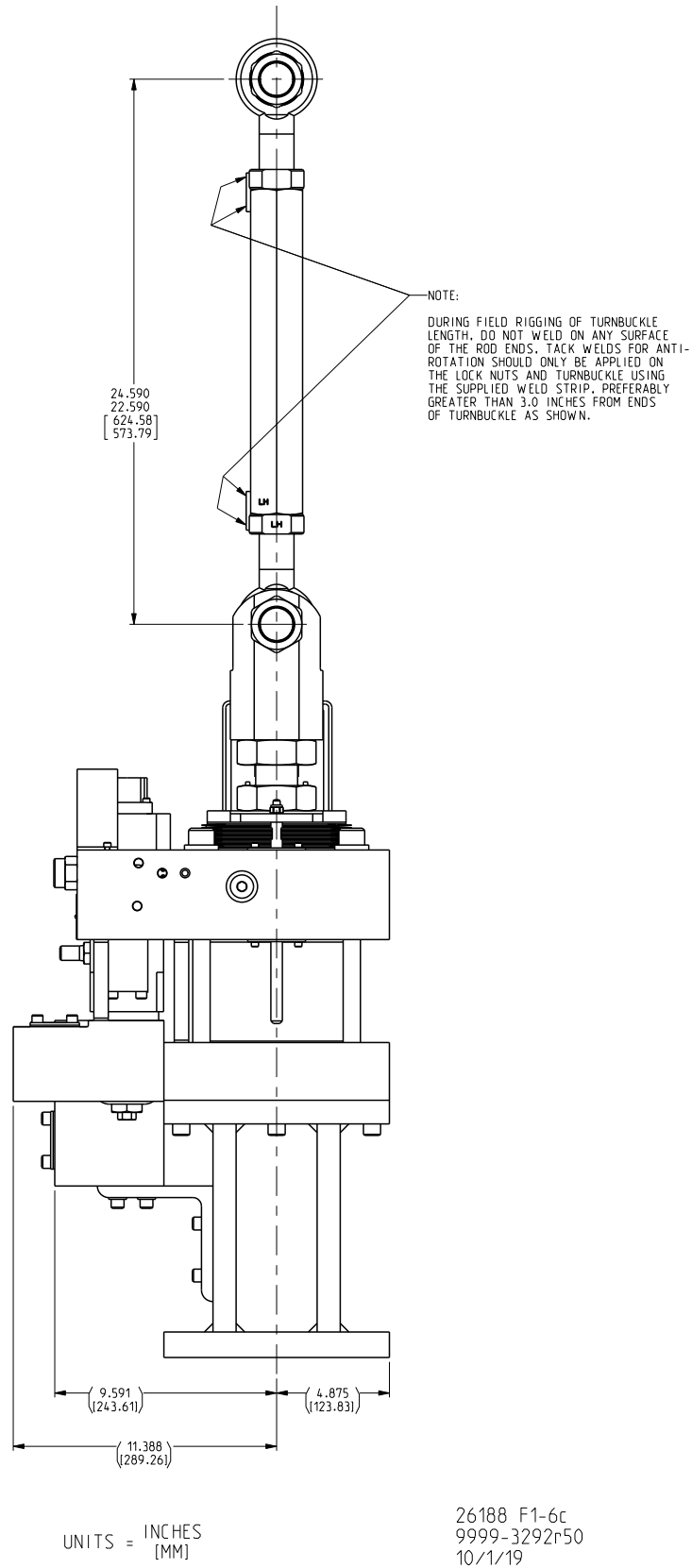

Figure 1-6c. 7F IGV Actuator with Hydraulic Trip, Low Pressure Trip Option, 180 Deg LVDT Orientation (right side view)

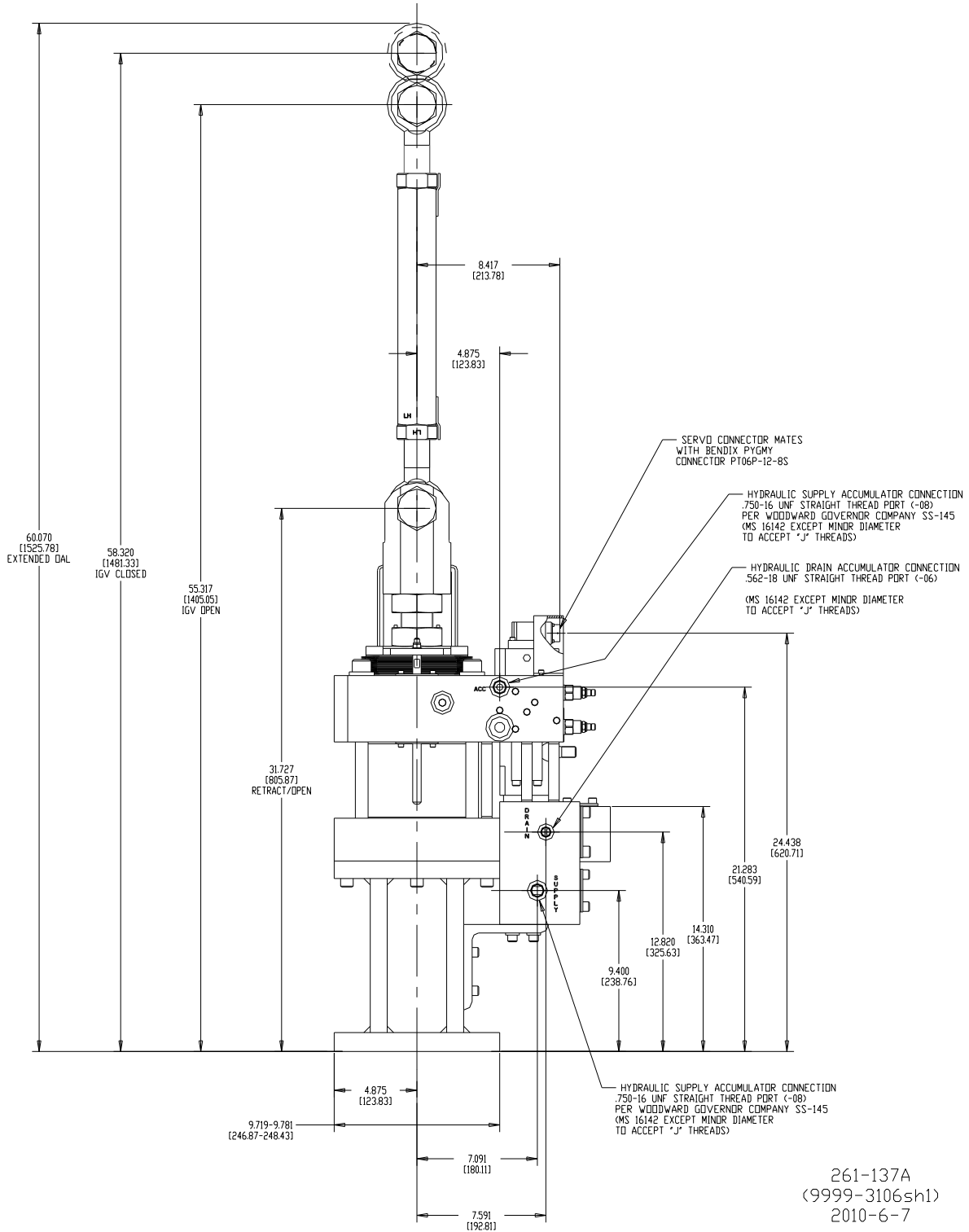

Figure 1-7a. 7F IGV Actuator with Hydraulic Trip, High Pressure Trip Option (left side view)

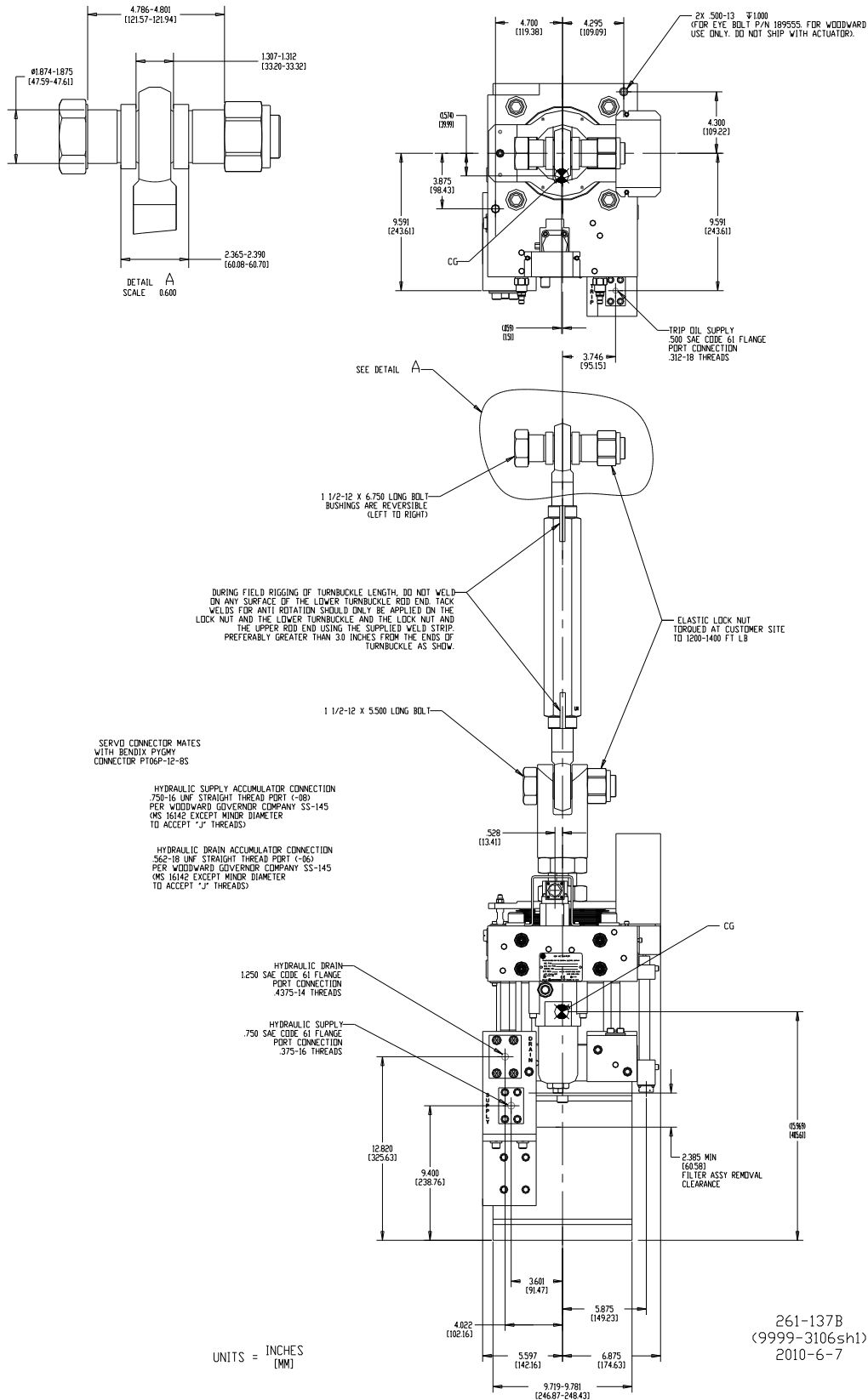

Figure 1-7b. 7F IGV Actuator with Hydraulic Trip, High Pressure Trip Option (front and top views)

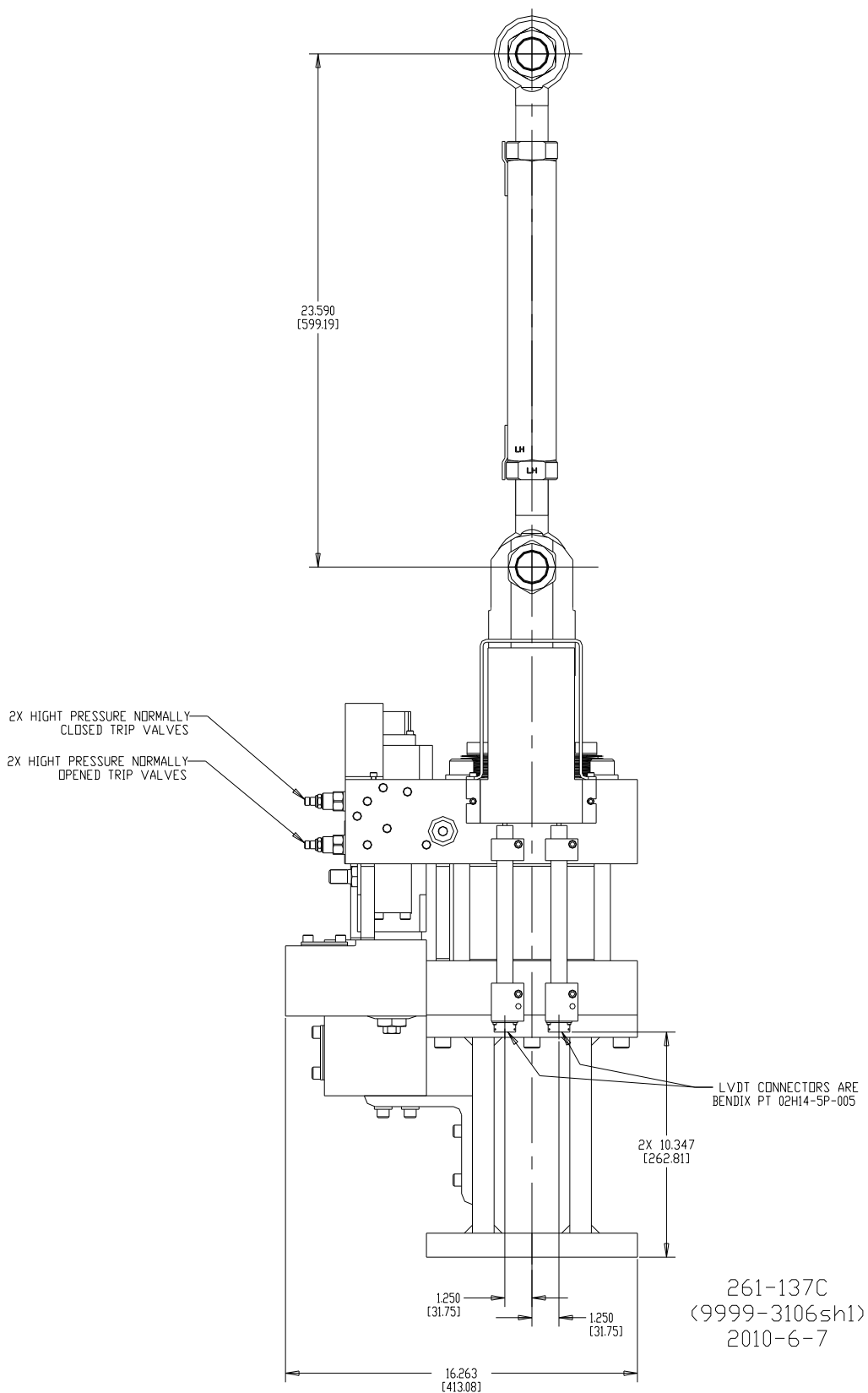

Figure 1-7c. 7F IGV Actuator with Hydraulic Trip, High Pressure Trip Option (right side view)

Table 1-3. IGVs with Electric Trip

ACTUATOR	STROKE LENGTH	STROKE TOLERANCE	RETRACTED/OPEN	IGV OPEN	IGV CLOSED	IGV O.A.L
	inches	inches	inches (mm)	inches (mm)	inches (mm)	inches (mm)
9904-1328	3.003	±0.020	31.602 (802.69) 31.852 (809.04)	55.087 (1399.21)	58.090 (1475.49)	59.840 (1519.94)
9904-1329	1.880	±0.020	29.850 (758.19)	49.850 (1266.19)	51.730 (1313.94)	53.480 (1358.39)

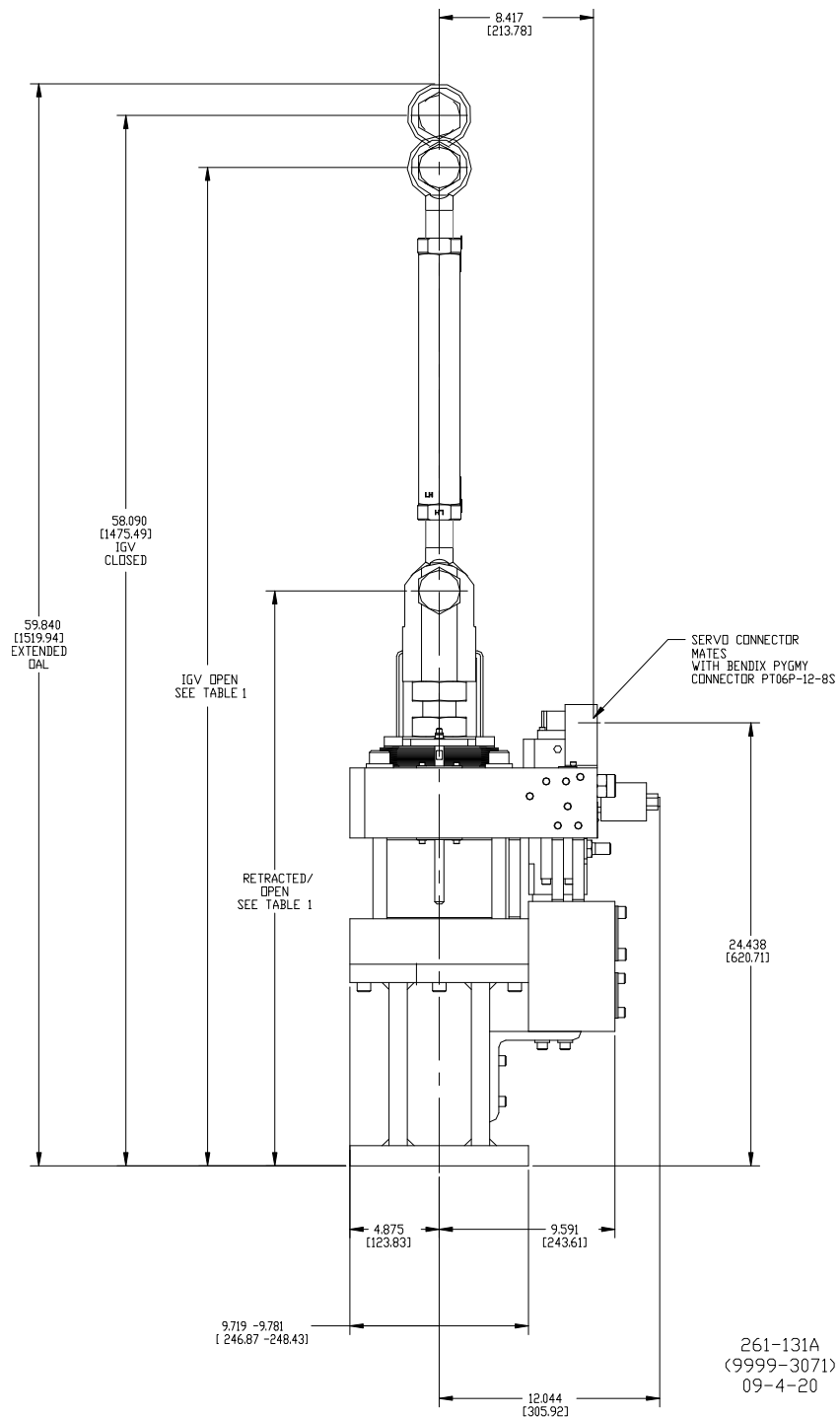

Figure 1-8a. 7F IGV Actuator with Electric Trip (left side view)

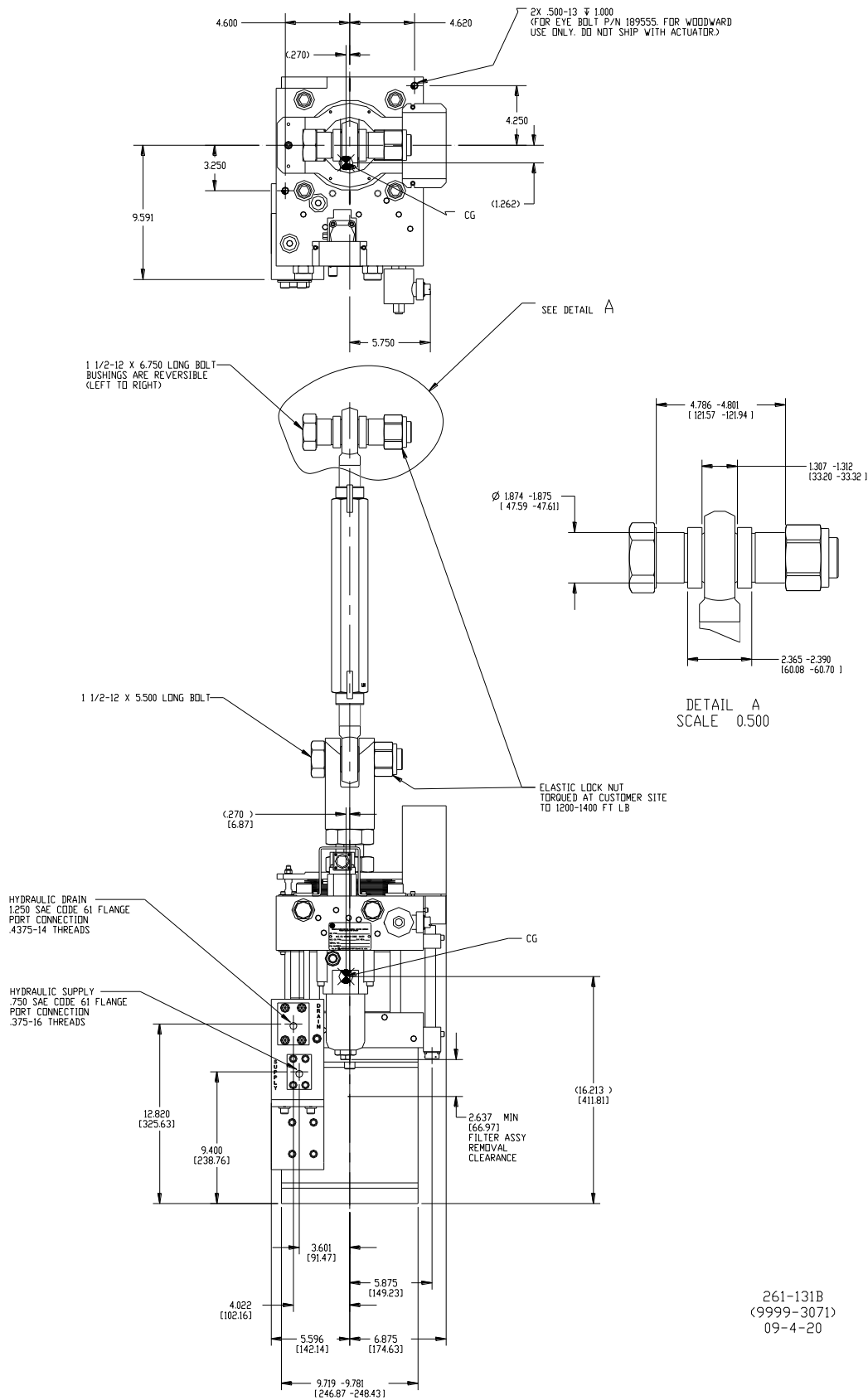

Figure 1-8b. 7F IGV Actuator with Electric Trip (front and top view)

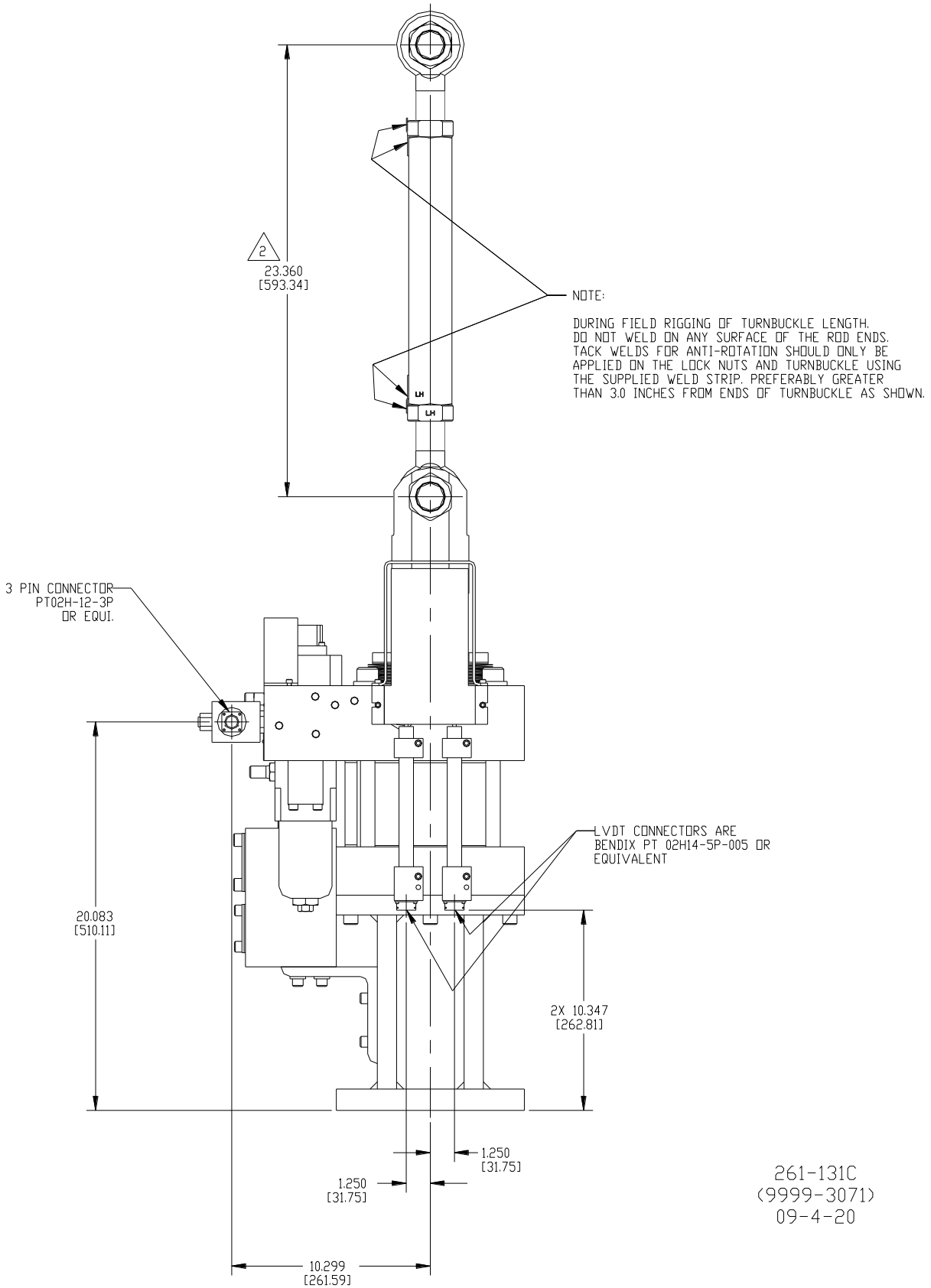

Figure 1-8c. 7F IGV Actuator with Electric Trip (right side view)

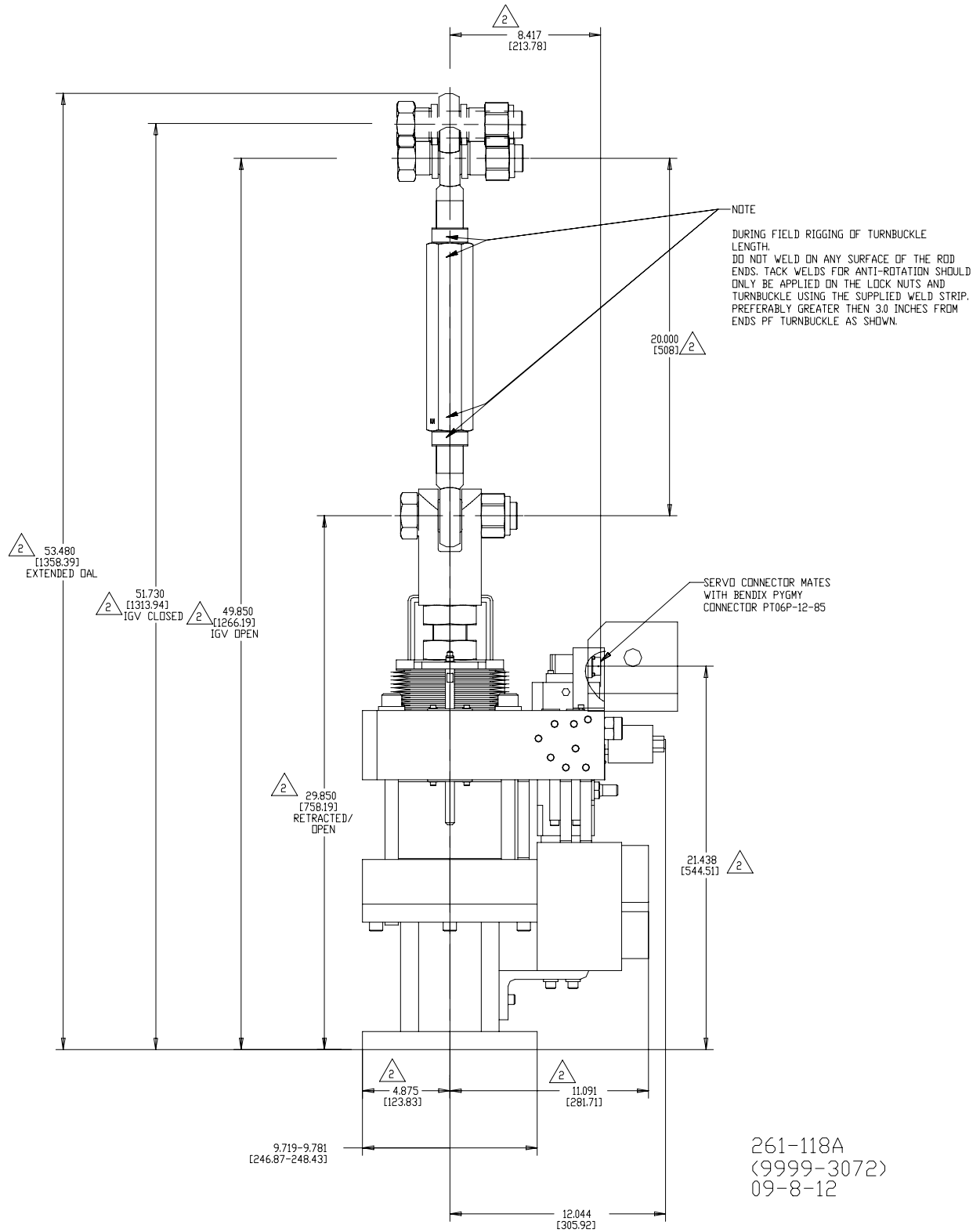

Figure 1-9a. 7E IGV Actuator with Electric Trip (left side view)

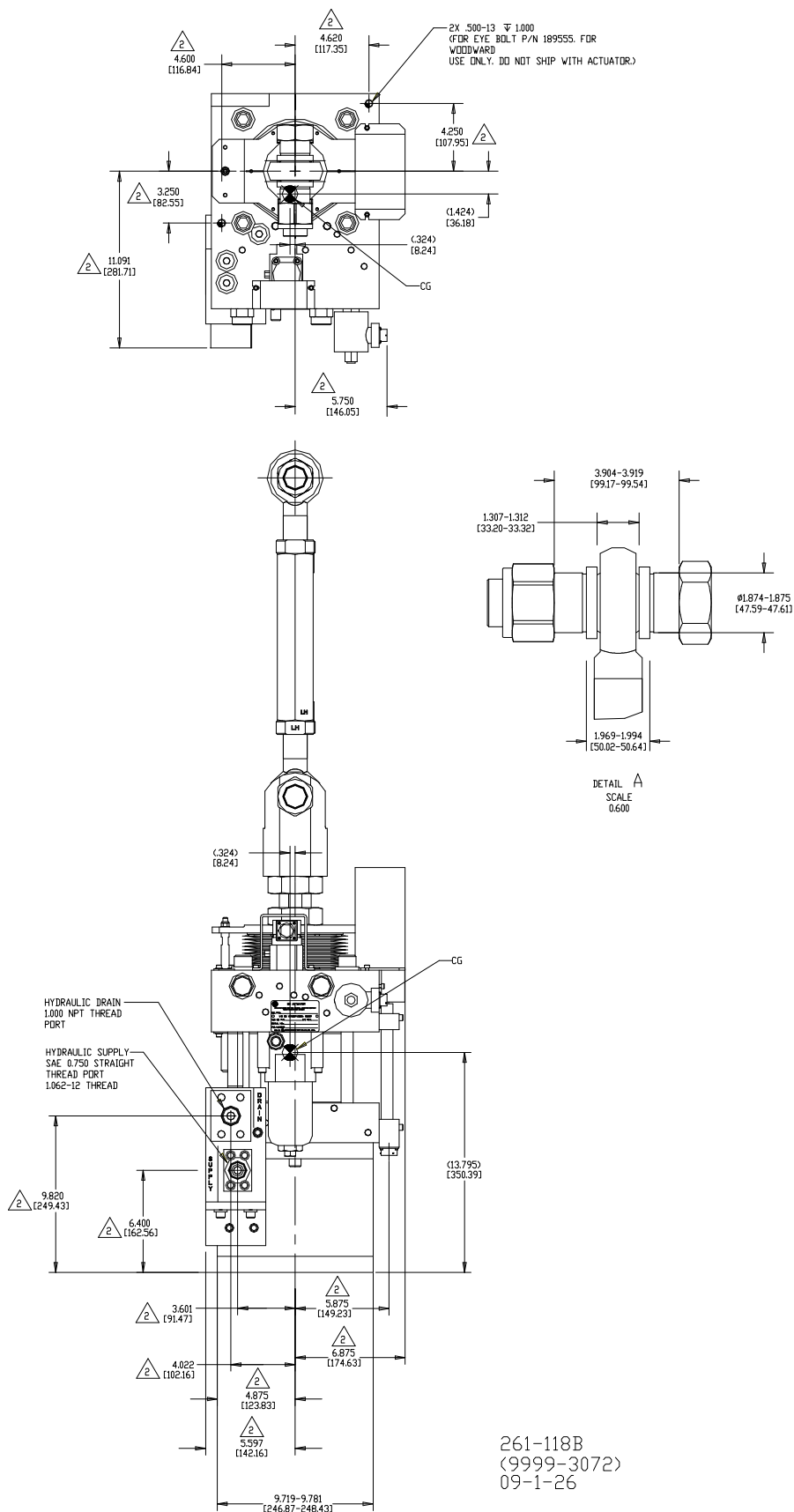
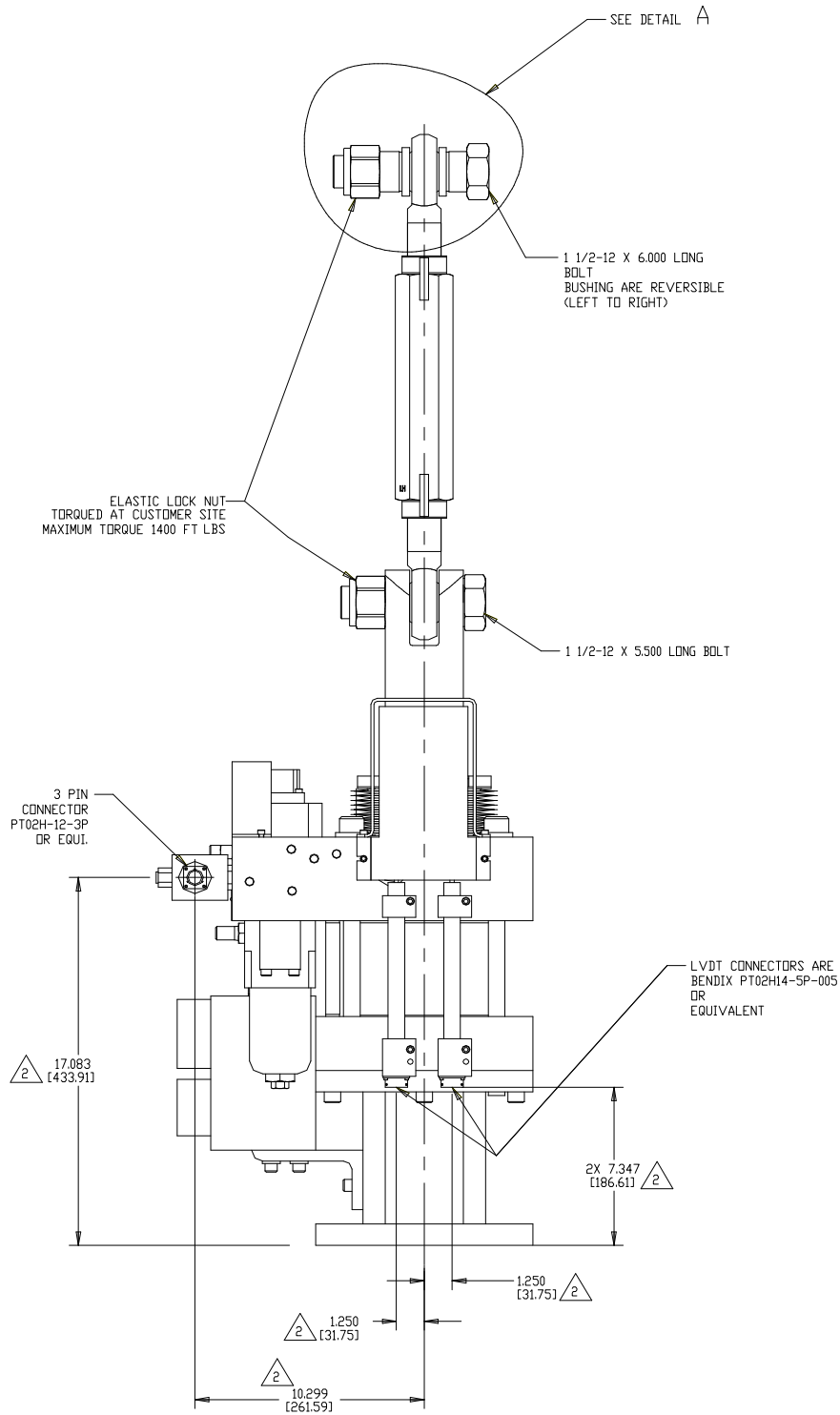

Figure 1-9b. 7E IGV Actuator with Electric Trip (front and top view)



ENGINEERING REFERENCE:

1. THIS OUTLINE APPLIES TO WGC 9904-1329 IGV ACTUATOR.
2. FOR FIRST ARTICLE INSPECTION (FAI) REQUIREMENTS SEE 4-09-2704
3. WHEN WELDING - DO NOT USE ELECTRICAL COMPONENTS AS WELDING GROUND.
4. APPROXIMATE WEIGHT 367 LBS (166 kg)

261-118C
(9999-3072)
09-1-26

Figure 1-9c. 7E IGV Actuator with Electric Trip (right side view)

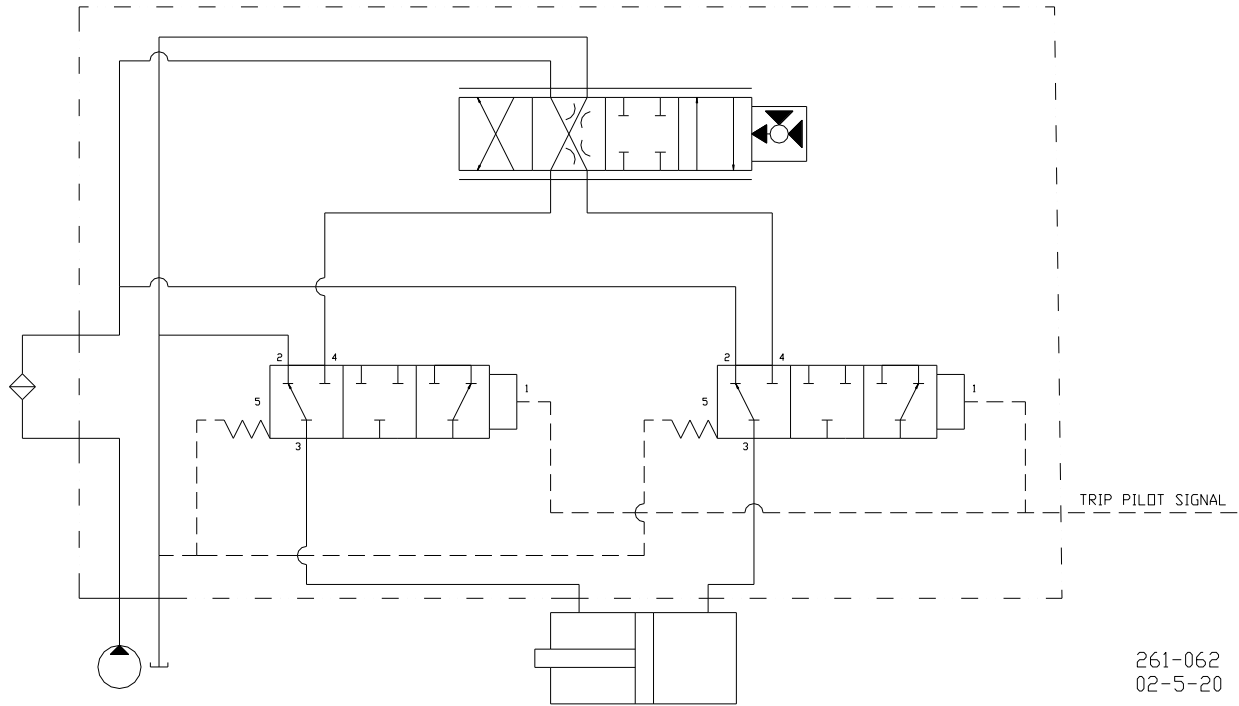

Figure 1-10. IGV Hydraulic Schematic (Hydraulic Trip System)

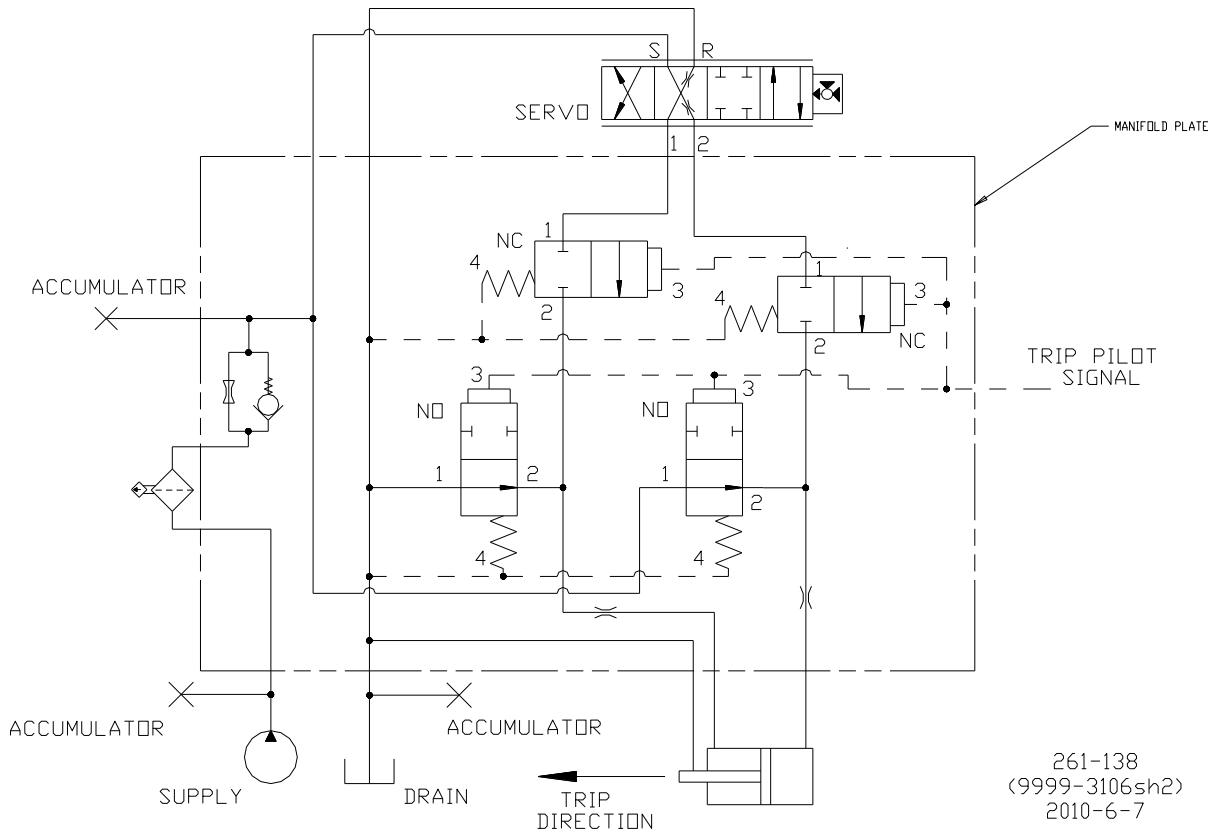

Figure 1-11. IGV Hydraulic Schematic, High Pressure Trip Option (Hydraulic Trip System)

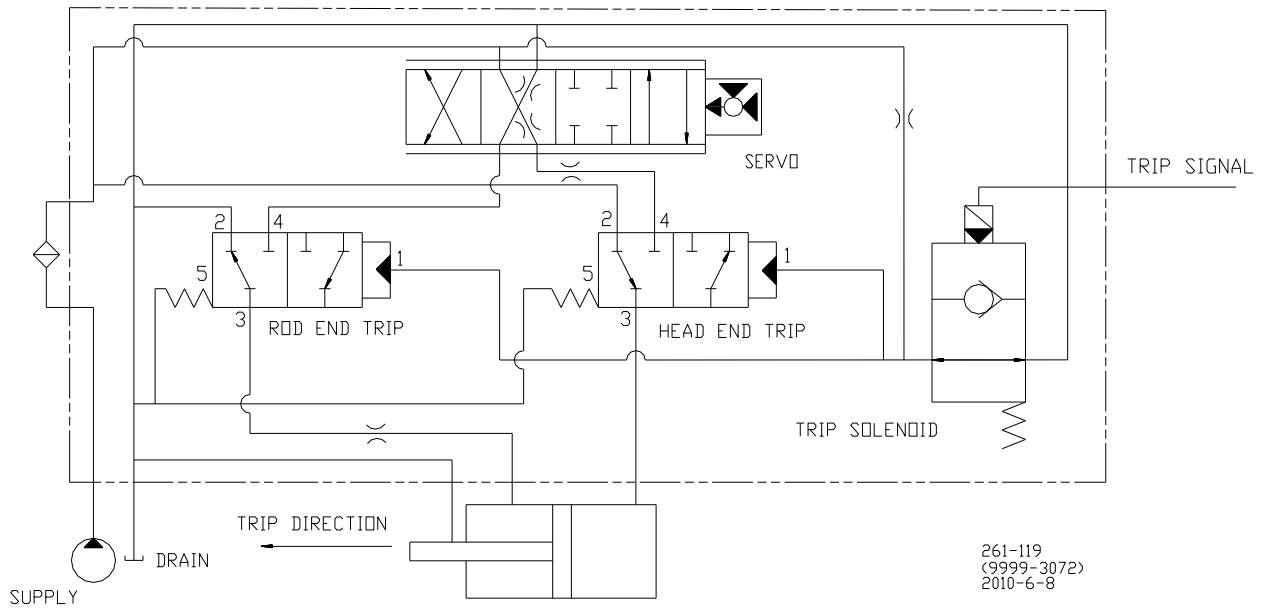

Figure 1-12. IGV Hydraulic Schematic (Electric Trip System)

SERVOVALVE

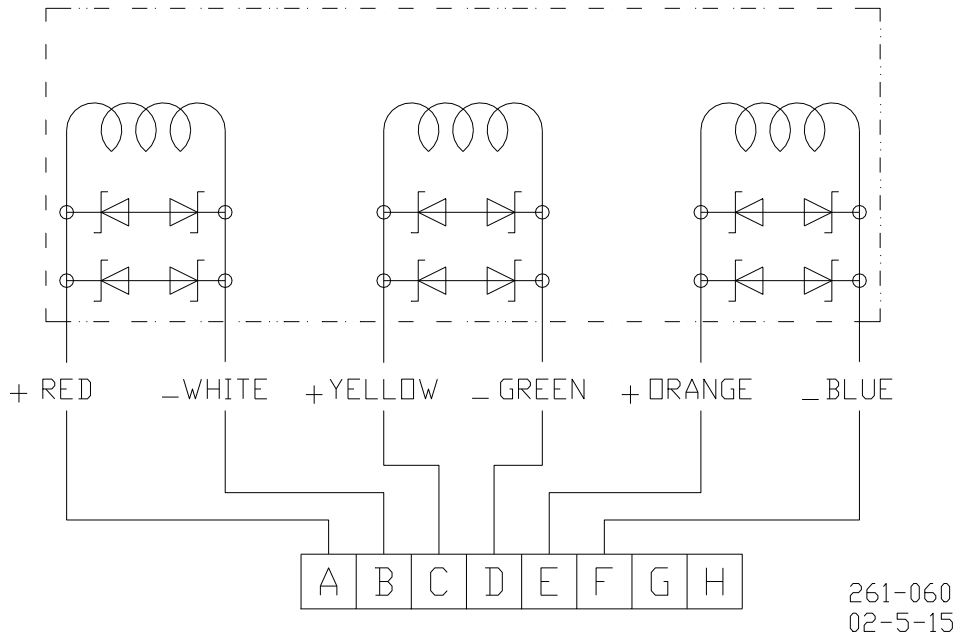

Figure 1-13. Servo Valve Electrical Schematic and Wiring Diagram

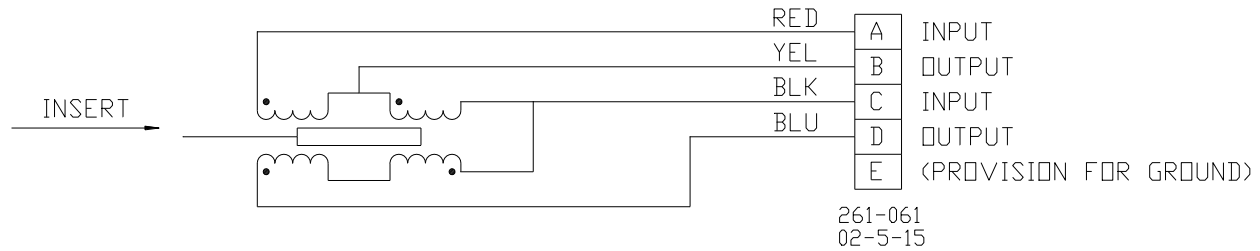
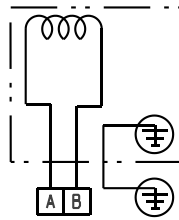

Figure 1-14. LVDT Electrical Schematic and Wiring Diagram

SOLENOID TRIP



26188 F1-15
9999-3072
12-4-2024

Figure 1-15. Servo Valve Electrical Schematic and Wiring Diagram (Electric Trip System)

NOTES

- These general reference outline drawings apply to various Woodward IGV actuators. Consult Woodward for the latest outline drawing for your particular IGV actuator.
- Installation Orientation Orientation vertical approximately as shown
See elsewhere in this manual for other installation recommendations
- Approximate Weight:
IGV Actuator with hydraulic trip 487 lb/221 kg
IGV Actuator with electric trip 386 lb/175 kg
- Service Manual Replacement Parts
Servo Valve—consult Woodward for part number
O-rings for servo valve—consult Woodward for part number
Filter element—consult Woodward for part number
Manual—consult Woodward for part number
LVDT—consult Woodward for part number
Trip relay valve—consult Woodward for part number
Seal kit for trip relay valve—consult Woodward for part number
- Description of IGV Actuator
Process fluid hydraulic fluid
Temperature range hydraulic fluid 50 to 150 °F/10 to 66 °C
ambient -40 to +250 °F/-40 to +121 °C
External leakage (none)
- Actuation
Cylinder bore 6.250 inch diameter (158.75 mm)
Rod diameter 2.500 inch diameter (63.50 mm)

Table 1-4. IGV Trip Type and Stroke

TURBINE FRAME	ACTUATOR	TRIP			STROKE inch
		HYDRAULIC		ELECTRIC	
		Low Pressure	High Pressure		
7FA	9904-533	Applicable	N/A	N/A	2.730
	9904-1448	Applicable	N/A	N/A	3.003
	9904-3181	Applicable	N/A	N/A	3.003
	9904-1328	N/A	N/A	Applicable	3.003
	9904-1532	N/A	Applicable	N/A	3.003
7FB	9904-1371	Applicable	N/A	N/A	2.830
7E	9904-989	Applicable	N/A	N/A	1.880
	9904-1329	N/A	N/A	Applicable	1.880

Static seals	Elastomer per US MIL-R-83248 (Viton)
Operating fluid	Petroleum-based hydraulic fluid as well as fire resistant hydraulic fluids such as Fyrquel EHC
Operating hydraulic pressure	1400 to 1800 psig/8274 to 11 722 kPa
7. Servo Valve Flow Rating	10.0 US gal/min (38 L/min) at 1000 psid (6895 kPa) valve drop, 4-way
Electrical input rating	±8 mA (sum of three coils)
First stage null bias	10 ±4% Rated Flow Cylinder Port 1 to Drain and Pressure to Port 2
Null Internal Leakage at 1600 psid (11 032 kPa)	0.42 US gal/min (1.6 L/min) (New) 0.75 US gal/min (2.8 L/min) (R+R)
Electrical connection	Mates with Bendix PYGMY Connector PT06P-12-8S

IMPORTANT

These general reference outline drawings apply to various Woodward IGV actuators. Consult Woodward for the latest outline drawing for your particular IGV actuator.

Chapter 2.

IGV Actuator Operation

The IGV actuator is controlled by an electronic servo-control system (not included), which compares the demanded and actual actuator positions. The control system modulates the input current signal to the electrohydraulic servo valve to minimize the positioning system error. See Figure 1-9 for a functional schematic of the dual-acting actuator with low pressure hydraulic trip system. See Figure 1-10 for a functional schematic of the dual-acting actuator with high pressure hydraulic trip system. See Figure 1-11 for a functional schematic of the dual-acting actuator with electric trip system. Hydraulic oil enters the actuator via a removable element filter with integral high ΔP indicator and is directed to a four-way electrohydraulic servo valve used in a three-way configuration. The PC1 control pressure output from the servo valve is directed to the upper cavity (rod end) of the hydraulic piston. When the force exerted by the hydraulic pressure exceeds the force of the opposing IGV force, the output piston retracts, rotating the Inlet Guide Vane ring in the opening direction.

The IGV actuator is available with either a hydraulic trip system or an electric trip system. A trip relay valve assembly is interposed between the electrohydraulic servo control valve and the servo output stage. In the hydraulic trip system, loss or reduction of the externally supplied trip signal pressure causes the trip relay valve to shift position. In the electric trip system, the removal of voltage from the trip solenoid allows pressure to the trip relay valve to be reduced, causing the trip relay valve to shift position. As the trip relay valve shifts position, it connects the lower cavity (head end) of the actuator piston directly to the hydraulic supply pressure. The supply pressure forces the actuation piston up to the extended position, rotating the Inlet Guide Vane ring to the closed position. Two redundant LVDT position feedback transducers are also mounted within each actuator. The LVDT sensor cores and support rods are connected to the main actuator output rod by an anti-rotation plate which is also coupled to a rod which is guided in a bushing. This guide bushing maintains LVDT alignment to minimize core damage due to sliding wear and the associated loss of sensing accuracy.

Chapter 3.

Standard Component Details

Triple Coil Electrohydraulic Servo Valve Assembly

The IGV actuator uses a two stage hydraulic servo valve to modulate the position of the output shaft and thereby control the inlet guide vane. The first stage torque motor uses a triple-wound coil, which controls the position of the first- and second-stage valves in proportion to the total electrical current applied to the three coils.

If the control system requires a rapid movement of the actuator, the total current is increased well above the null current. In such a condition, supply oil is admitted to the appropriate actuator piston cavity. The flow rate delivered to the piston cavity is proportional to the total current applied to the three coils. Thus, the actuator stroke velocity and the valve opening are also proportional to the current (above null) supplied to the torque motor above the null point.

If the control system requires a rapid movement to close the IGV actuator, the total current is reduced well below the null current. In such a condition, the actuator piston cavity is connected to the hydraulic drain circuit. The flow rate returning from the upper piston cavity of the valve is proportional to the magnitude of the total current below the null value. The flow rate and closing velocity of the valve is in this case proportional to the total current below the null point.

Near the null current, the servo valve essentially isolates the piston cavities from the hydraulic supply and drain, and the piston pressure is balanced to maintain a constant position. The control system, which regulates the amount of current delivered to the coils, modulates the current supplied to the coil to obtain proper closed loop operation of the system.

Trip Relay Valve Assembly

Depending on whether the actuator is low pressure trip, high pressure trip, or electric trip, it utilizes either two hydraulically operated three-way cartridge valves, four hydraulically operated logic element valves, or an electric solenoid valve to switch the position of the IGV actuator.

Low Pressure Trip System

On the low pressure system, one valve connects a servo port to the actuator rod end, and the other connects the other servo port to the actuator head end with pilot pressure applied. With no pilot pressure, the pump is connected to the actuator head end port, and the drain port is connected to the actuator rod end port. The valves are designed to ensure that pickup and drop-out points occur at less than 40 psid (276 kPa). When the trip circuit pressure increases to its pickup pressure, the three-way relay valves shift position. The servo valve control ports are then connected to the actuator ports. Depending on the command signal, one actuator port is connected to pump pressure while the other is connected to tank, allowing the actuator to function.

When the trip circuit pressure decreases to its drop-out point, the three-way trip valves shift position so that the rod end actuator port is connected to the hydraulic drain circuit, and the head end actuator port is connected directly to supply pressure. As the pressure increases to the actuator head end cavity, and pressure falls off in the actuator rod end cavity, the actuator rapidly extends the piston to the vane closed position, closing the inlet guide vanes of the turbine.

High Pressure Trip System

On the high pressure system, when trip pressure is applied to the pilot port of the upper logic element cartridges, they shift and allow the servo ports to connect to the respective ends of the hydraulic cylinders. When trip pressure is applied to the pilot ports of the lower logic element cartridges, they close off the direct connections from the upper end of the cylinder to drain, and from the lower end of the cylinder to supply pressure. With the cartridges in this position, the servo valve can modulate the cylinder for normal operation of the actuator.

When the trip pressure falls below 340 psig (2344 kPa) at the cartridge pilot ports, the upper cartridges both close, thereby isolating the servo valve from the hydraulic cylinder. The lower cartridge valves open when the trip pressure is removed from the cartridge pilot ports. This connects the upper end of the hydraulic cylinder directly to drain and the lower end of the cylinder directly to hydraulic line pressure, causing the cylinder to fully extend regardless of the servo valve control signal.

Electric Trip System

In the electric trip system, the trip pilot pressure is made available internally from the manifold. This system includes an electric trip solenoid controlled by the customer. When the solenoid is powered, pilot pressure is provided to the trip valves, and the actuator is under servo valve control as described above. Tripping action is effected by removing power from the solenoid that results in reducing trip circuit pressure.

When the trip circuit pressure decreases to its drop-out point, the three-way trip valves shift position so that the rod end actuator port is connected to the hydraulic drain circuit, and the head end actuator port is connected directly to supply pressure. As the pressure increases to the actuator head end cavity, and pressure falls off in the actuator rod end cavity, the actuator rapidly extends the piston to the vane closed position, closing the inlet guide vanes of the turbine.

Hydraulic Filter Assembly

The IGV actuator is supplied with an integrated, high-capacity filter. This broad-range filter protects the internal hydraulic control components from large oil-borne contaminants that might cause the hydraulic components to stick or operate erratically. The filter is supplied with a visual indicator which indicates when the pressure differential exceeds the recommended value, indicating that replacement of the element is necessary.

LVDT Position Feedback Sensors

The IGV actuator uses dual LVDTs for position feedback. The LVDTs are factory set to give 0.7 ± 0.1 Vrms feedback in extended position.

Chapter 4. Installation

General

See the outline drawings (Figures 1-1 through 1-6 for the hydraulic trip or Figures 1-7 and 1-8 for the electric trip) for:

- Overall dimensions
- Hydraulic connections and fitting sizes
- Electrical connections
- Lift points
- Weight of the actuator

The design of the IGV actuator requires that the output shaft be mounted vertically. Additionally, a vertical actuator position is generally preferred to conserve floor space as well as ease of making electrical, fuel, and hydraulic connections and changing the hydraulic filter element.

The IGV actuator is designed for support by an actuator base. Additional supports are neither needed nor recommended.



Due to typical noise levels in turbine environments, hearing protection should be worn when working on or around this product.



The surface of this product can become hot enough or cold enough to be a hazard. Use protective gear for product handling in these circumstances. Temperature ratings are included in the specification section of this manual.



Woodward recommends lifting the IGVA by installing two lifting eyes in the 0.500 x 13 tapped holes shown in Figures 1-1b/1-2b/1-3b/1-4b/1-5b/1-6b/1-7b/1-8b. If the unit must be lifted by slings, Woodward recommends running a strap through the 2" (51 mm) diameter hole on the yoke. This will extend the IGV rod as the unit is lifted. If installing straps on any other location, observe the center of gravity noted in Figures 1-1b/1-2b/1-3b/1-4b/1-5b/1-6b/1-7b/1-8b and take care that the straps do not press against other components such as the LVDTs, servo valve, or anti-rotation rod.



External fire protection is not provided in the scope of this product. It is the responsibility of the user to satisfy any applicable requirements for their system.

Unpacking

The actuator is shipped with the turnbuckle linkage disconnected from the output shaft but included in the same shipping container along with necessary mounting hardware. Check the shipping container for all components before removing it from the area.

Hydraulic Connections

For the hydraulic trip system IGVA, there are three hydraulic connections that must be made to each actuator: supply, return, and trip.

The connections to the actuator with Low Pressure Trip signal, used on GE Frame 7F model turbines, are SAE Code 61 4-bolt flanges.

The connections to the actuator with High Pressure Trip signal, used on GE Frame 7F model turbines, are SAE Code 61, 4-bolt flanges. Additionally, High Pressure trip models use two hydraulic ports to connect two Hydraulic Accumulators (one placed on the hydraulic supply line and one placed on the hydraulic drain line). There are two possible connections provided for the accumulator on the supply line (depending on hydraulic infrastructure accessibility). During actuator operating, only one port needs to be connected with the hydraulic accumulator; the second port must be plugged so that it is leak-proof.

The connections to the actuator used on GE Frame 7E model turbines use SAE straight thread O-ring connections for the trip and main supply ports and a 1" NPT connection for the drain port. The tubing up to the actuator must be constructed to eliminate any transfer of vibration or other forces into the actuator. For the electric trip system IGVA, there are only two hydraulic connections, supply and return; the same as described above.

Make provisions for proper filtration of the hydraulic fluid that will supply the actuator. The system filtration should be designed to assure a supply of hydraulic oil with a maximum ISO 4406 contamination level of 18/16/13 and a preferred level of 16/14/11. The filter element included with the actuator is not intended to provide adequate filtration over the entire life of the actuator.

The hydraulic supply to the actuator is to be 0.750 inch (19.05 mm) tubing capable of supplying 10 US gal/min (38 L/min) at 1400–1800 psig (9653–12 411 kPa).

The hydraulic drain for the 7F should be 1.25 inch (31.8 mm) tubing and must not restrict the flow of fluid from the actuator. The hydraulic drain for the 7E should be 1.00 inch (25.4 mm) tubing and must not restrict the flow of fluid from the actuator. The drain pressure must not exceed 30 psig (207 kPa) under any condition.

The hydraulic accumulator's ports for the 7F with High Pressure tip signal should be 0.750 inch (19.05 mm) tubing for an accumulator connected to the supply line, and 0.562 inch (14.27 mm) tubing for an actuator connected to the drain line.

The trip relay valve supply should be 0.500 inch (12.70 mm) tubing. The Trip Relay Pressure should be above 40 psig (276 kPa) to enable the actuator to function.

Electrical Connections

WARNING

Due to the hazardous location listings associated with this product, proper wire type and wiring practices are critical to operation.

NOTICE

Do not connect any cable grounds to “instrument ground”, “control ground”, or any non-earth ground system. Make all required electrical connections based on the wiring diagrams (Figures 1-12/ 1-13/1-14).

The use of cable with individually-shielded twisted pairs is recommended. All signal lines should be shielded to prevent picking up stray signals from nearby equipment. Installations with severe electromagnetic interference (EMI) may require shielded cable run in conduit, double-shielded wire, or other precautions. Connect the shields at the control system side or as indicated by the control system wiring practices, but never at both ends of the shield such that a ground loop is created. Wires exposed beyond the shield must be less than 2 inches (51 mm). The wiring should provide signal attenuation to greater than 60 dB.

The servo valve cable should consist of three individually shielded twisted pairs. Each pair should be connected to one coil of the servo valve as indicated in Figure 1-12 (wiring diagram).

The LVDT cable must consist of four individually shielded twisted pairs. Two separate pairs should be used for each of the excitation voltages to the LVDT, and two separate pairs used for each of the feedback voltages from the LVDT, as indicated in Figure 1-13 (wiring diagram).

The electric trip solenoid valve must use wire suitable for at least 300 V.

Electronic Settings

Dynamic Tuning Parameters

It is imperative that the correct dynamic characteristics of this actuator be input into the control system to ensure that the operation of the actuator/control system is within acceptable limits.

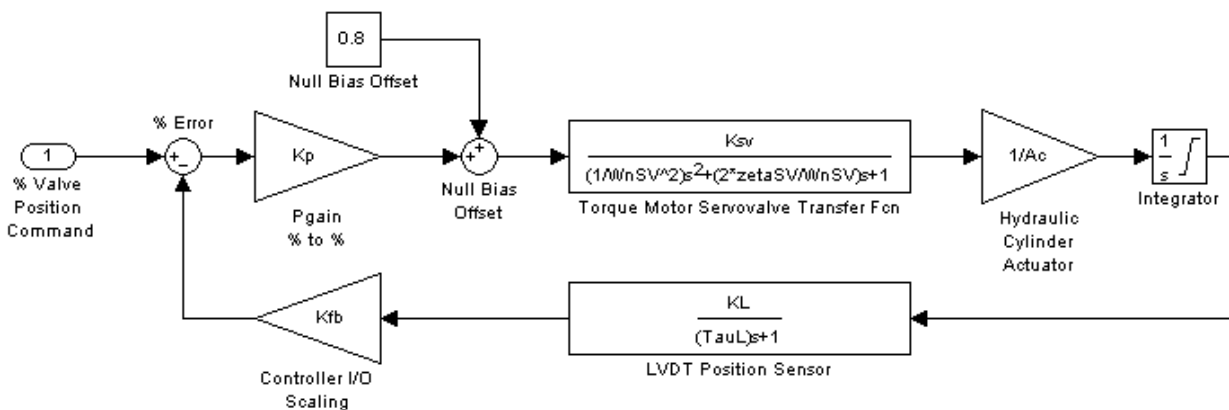

Figure 4-1. IGV Actuator Block Diagram

A_c Hydraulic cylinder working area (in²) 30.68 in² extend area, 25.77 in² retract area
 K_{sv} Servo valve flow gain (in³/s) = 6.1 in³/s/mA
 K_L LVDT gain (Vrms/inch). Gain = 1.0180 Vrms/inch

ξ servo valve damping ratio = 0.7
 ω_n servo valve natural frequency (rad/s) = 520 rad/s (83 Hz)
 τ_L LVDT time constant (s) = 0.005 (depends on excitation/demodulation)

[in² = square inches; 1 in² = 645.16 mm²]

[in³ = cubic inches; 1 in³ = 16.387 mm³]

Null Current Adjustment

Every IGV actuator shipped contains documentation that gives the actual null current as measured by Woodward. It is imperative that the control system null current match the as-measured current for each IGV actuator in the system. Incorrect null current setting (with proportional control only) will result in position error.

Rigging Procedure

The actuator is shipped with documentation which contains the appropriate LVDT feedback signals for each LVDT in the fully extended and retracted positions (assuming 7.0 Vrms excitation at 3000 Hz).

Once the control system is connected to the actuator and control of the actuator is established, set the command position to 0% of full stroke. Measure the feedback voltage from each LVDT. Adjust the Offset in the feedback loop until the feedback voltage matches the documented values for that position. Adjust the command position to 100% of full stroke. Adjust the Gain of the feedback loop until the LVDT feedback voltage matches the documented values. Set the command position to close the vane (actuator extend). Visually verify that the vane (actuator) is opened and that the feedback voltage from the LVDT is 0.7 ± 0.1 Vrms. This process may have to be repeated to ensure the feedback voltages at both the 0% and 100% command positions match the documented values.

NOTICE

During field rigging of turnbuckle length, do not weld on any surface of the rod ends. Tack welds for anti-rotation should only be applied on the lock nuts and turnbuckle using the supplied weld strip, preferably more than 3.0 inches (76 mm) from the ends of the turnbuckle as shown in Figures 1-2c/1-3c/1-4a/1-5c/1-6b/1-7c/1.8a.

Chapter 5. Maintenance and Hardware Replacement

Maintenance

The IGV actuator requires no maintenance or adjustment in preparation for (or during) normal operation.

Woodward recommends routine checks of the DP gauge on the filter assembly to verify that the filter is not partially clogged. If the DP indicator shows red, the filter element needs to be replaced.

Woodward recommends a yearly removal and cleaning of the Trip Relay Valve Cartridges to prevent build-up of oil varnish or contaminants which may prevent proper operation of the Trip Relay Valve.

Remove each valve as described below and soak in a solvent (Stoddard or kerosene based) compatible with the fluorocarbon O-rings. Actuate the valve by hand and blow clean with compressed air. Verify smooth operation of the Trip Relay Valve and ensure no sticking or binding is present.

In the event that any of the standard components of the actuator become inoperative, field replacement of components is possible. Contact a Woodward representative for assistance.



WARNING

Any cleaning by hand or with water spray must be performed while the area is known to be non-hazardous to prevent an electrostatic discharge in an explosive atmosphere.

Hardware Replacement



WARNING

EXPLOSION HAZARD—Do not connect or disconnect while circuit is live unless area is known to be non-hazardous.

Substitution of components may impair suitability for Zone 2 applications.



WARNING

To prevent possible serious personal injury, or damage to equipment, be sure all electric power, hydraulic pressure, and vane force have been removed from the actuator before beginning any maintenance or repairs.



WARNING

Due to typical noise levels in turbine environments, hearing protection should be worn when working on or around the IGV actuator.

See the outline drawings (Figures 1-1 through 1-8) for the location of items.

Hydraulic Filter Assembly/Cartridge

The hydraulic filter is located on the hydraulic manifold, hanging directly under the top manifold directly under the servo valve.

Replacement of Filter Assembly

1. Remove four 0.312-18 UNC socket head cap screws.
2. Remove the filter assembly from the manifold block.

IMPORTANT

The filter contains a large amount of hydraulic fluid that may be spilled during filter removal.

3. Remove the two O-rings present in the interface between the filter and the manifold.
4. Obtain a new filter assembly.
5. Place two new O-rings in the new filter assembly.
6. Install the filter onto the manifold assembly. Be sure to place the filter in the correct orientation. See the outline drawings (Figures 1-1 through 1-8).
7. Install four 0.312-18 cap screws through the filter into the manifold, and torque to 20–27 lb-ft (27–37 N·m).

Replacement of Filter Cartridge

IMPORTANT

The filter contains a large amount of hydraulic fluid that may be spilled during filter removal.

1. Using a 1-5/16 inch (~33+ mm) wrench, loosen the bowl from the filter assembly.
2. Remove the filter element by pulling it downward.
3. Obtain a new filter element.
4. Lubricate the O-ring on the ID of the cartridge with hydraulic fluid.
5. Install the cartridge into the assembly by sliding the open end of the cartridge upward onto the nipple.
6. Install the filter bowl. Tighten to 25–30 lb-ft (34–41 N·m).

Trip Relay Valve Cartridges Replacement

The trip relay valve cartridges are located in the hydraulic manifold block (Figure 1-1b item 22 for Low Pressure Trip option and Figure 1-6c for High Pressure Trip Option).

IMPORTANT

Hydraulic fluid may spill during cartridge removal.

1. Using a 1.25 inch (~32– mm) wrench in Low Pressure trip signal units or a 0.875 inch (~22+ mm) wrench on High Pressure Trip units (see Table 1-4), loosen the trip relay valves from the hydraulic manifold.
2. Slowly remove the cartridges from the manifold.
3. Obtain new trip relay valve cartridges and verify part number and revision with the existing unit.
4. Verify that all O-rings and backup rings are present on new cartridge.
5. Lubricate the O-rings with hydraulic fluid or petroleum jelly.
6. Install the cartridge into the manifold housing.
7. Torque to 33–35 lb-ft (45–47 N·m).

Trip Relay Solenoid Valve

The trip relay solenoid valve is located on the same side of the hydraulic manifold as the trip relay cartridge valves. See the outline drawings (Figures 1-7, 1-8).

1. Disconnect the solenoid valve Bendix connector from the electric supply.
2. Using a 1-1/4 inch wrench (~32– mm), loosen the solenoid valve from the hydraulic manifold.
3. Slowly remove the solenoid valve from the manifold. There could be some hydraulic fluid upon removal. Be cautious when handling.
4. Obtain a new solenoid valve from Woodward.
5. Verify that both O-rings and back-up ring are present on the new valve.
6. Lubricate the O-rings with hydraulic fluid or petroleum jelly.
7. Install the new solenoid valve into the hydraulic manifold.
8. Torque the solenoid valve to 17–29 lb-ft (23–39 N·m).
9. Connect the solenoid valve Bendix connector to the electric supply.

10. Check for external leakage upon pressurizing the hydraulic system.

Servo Valve Replacement

The servo valve is located on the hydraulic manifold directly above the filter assembly. Refer to the outline drawings (Figure 1-1b item 19).

1. Disconnect the servo valve cable from the servo valve.
2. Remove the four #10-32 UNF socket head cap screws holding the servo valve to the manifold (Figure 1-1b item 18).
3. Discard the four O-rings between the servo valve and the manifold.
4. Obtain a replacement servo valve and verify part number and revision with the existing unit.
5. Remove the protective plate from the replacement servo valve and verify that O-rings are on all four counter bores of the servo valve.
6. Place the servo valve onto the hydraulic manifold. Be sure to orient the servo valve to match the original orientation. Be sure that all four O-rings remain in their proper location during assembly.
7. Install four #10-32 UNF socket head cap screws and torque to 56–75 lb-in (6.3–8.5 N·m).

LVDT Replacement



Use care and follow all instructions after removal of supply pressure and blocking the actuator in extended position. Significant weight is being supported, and the potential to cause bodily injury is high if all safety precautions are not followed.

The LVDTs are located on the right side of the upper and lower manifolds when viewing the front (hydraulic port connections) of the actuator. Refer to the outline drawings (Figures 1-1b/1-1c/1-2b/1-2c/1-3b/1-3c/1-4b/1-4c/1-5b/1-5c/1-6b/1-6c/1-7b/1-7c/1-8b/1-8c).

1. Shut off the hydraulic supply to the IGV actuator and ensure that the actuator is in the fully extended position. You may need to block it in this position.
2. Remove the LVDT covers (item 76 on Figures 1-1b and 42 on Figure 1-1c) by removing the four #10-32 UNF screws (items 17 on Figures 1-1b and 1-1c) holding the access covers on the top and side of the LVDTs.
3. Disconnect both sets of LVDT connectors.
4. Remove the #10-32 UNF locknuts and washers (items 29 and 30 on Figure 1-1b) from the defective LVDT rod holding the 0.250 inch flats on the rod.
5. Lower the rod from the anti-rotation plate and allow it to rest on the LVDT.
6. Remove the two 0.250-20 UNC socket head cap screws (items 37 Figure 1-1c) holding the LVDT bracket to the upper and lower manifolds.
7. Carefully remove the LVDT assembly from the actuator by vertically lowering it away from the IGV. Take care not to damage the good LVDT housing and rod.
8. Obtain a replacement LVDT and verify part number and revision with the existing unit.
9. Install the bottom #10-32 UNF locknut and washer on the replacement LVDT rod. Install the new rod into the anti-rotation plate, positioning the rod height to approximately match the other LVDT rod height.
10. Install the #10-32 UNF locknut and washer onto the LVDT rod but do not torque the nut at this time.
11. Carefully slide the replacement LVDT over the LVDT rod. **Be very careful not to force the LVDT at any time since this could damage the LVDT rod.**
12. Install the two 0.250-20 UNC socket head cap screws holding the LVDT bracket to the upper and lower manifolds and torque to 120–160 lb-in (13.6–18.1 N·m).
13. Connect the LVDT cable to the new LVDT.
14. Reattach the hydraulic drain connection.
15. Once the LVDT is installed, it must then be calibrated as described below.
16. Covers will be attached after calibration.

LVDT Calibration

- Whenever an LVDT is replaced, or whenever its core rod adjustment is disturbed, the LVDT output voltage must be calibrated in the following way.



Use care and follow all instructions after removal of supply pressure and blocking the actuator in extended position. Significant weight is being supported and the potential to cause bodily injury is high if all safety precautions are not followed.

- If not replacing an LVDT but calibrating:
 - Ensure that the actuator it is in its fully extended position. Shut off the hydraulic supply to the IGV actuator and block it in this position.
 - Remove the LVDT covers (item 76 on Figures 1-1b and 42 on Figure 1-1c) by removing the four #10-32 UNF screws (items 17 on Figures 1-1b and 1-1c) holding the access covers on the top and side of the LVDTs.
- Adjust the LVDT rod so that the output of the replaced LVDT is 0.7 ± 0.1 Vrms with the IGV actuator fully extended (inlet guide vane closed).
- Tighten the #10-32 UNF locknut to 32–35 lb-in (3.6–4.0 N·m).
- Attach an accurate stroke measurement device (dial indicator or equivalent), capable of measuring 3 inches (76 mm) of stroke, to the IGV actuator body.
- Apply hydraulic pressure to the IGV actuator and manually command the actuator to retract stroke:

Table 5-1. Turbine Frame, Actuator, and Stroke

TURBINE FRAME	ACTUATOR	STROKE	
		inches	mm
7FA	9904-533	2.73 ±0.02	69.3 ±0.5
	9904-1448		
	9904-3181	3.003±0.02	76.3±0.5
	9904-1328		
7FB	9904-1532	3.003±0.02	76.3±0.5
	9904-1371	2.83 ±0.02	71.9 ±0.5
7E	9904-989	1.88 ±0.02	47.8 ±0.5
	9904-1329		

Note and record the LVDT output voltages at this 2.73 inches (69.3 mm) or at this 3.003 inches (76.3 mm) for the 7FA, 2.83 inches (71.9 mm) for the 7FB, or 1.88 inches (47.8 mm) stroke position for the 7E.

- Remove the actuator control command, returning the actuator to its rest (inlet guide vane closed) position.
- Shut off the IGV actuator hydraulic supply.
- Update the IGV actuator control logic with the new LVDT output voltage value.

Troubleshooting Charts

Faults in the IGV control may be associated with speed variations of the prime mover, but such speed variations may not always indicate system faults. Therefore, when improper IGV operation occurs, check all components, including the turbine for proper operation. Refer to applicable electronic control manuals for assistance in isolating the trouble. The following steps describe troubleshooting for the IGV actuator.

Disassembly of the IGV actuator in the field is **not** recommended due to the special tools and procedures required. Under unusual circumstances where disassembly becomes necessary, all work and adjustments should be made by personnel thoroughly trained in the proper procedures and tools.

When requesting information or service help from Woodward, it is important to include the part number and serial number of the actuator assembly in your communication.

Symptom	Possible Causes	Remedies
External hydraulic leakage	Static O-ring seal(s) missing or deteriorated	Replace O-rings fitted to user-serviceable components (filter, servo valve, trip relay valve) as needed. Otherwise, return actuator to Woodward for service.
	Dynamic O-ring seal missing or deteriorated	Return actuator to Woodward for service.
Internal hydraulic leakage	Servo valve internal O-ring seal(s) missing or deteriorated	Replace servo valve.
	Servo valve metering edges worn	Replace servo valve.
	Piston seal missing or deteriorated	Return actuator to Woodward for service.
Actuator will not open (actuator retract)	Servo valve command current incorrect. (The sum of the current through the three coils of the servo valve must be greater than the null bias of the servo valve for the actuator to open.)	Trace and verify that all wiring is in accordance with the electrical schematic (Figures 1-12, 1-13, and 1-14) and the GE system wiring schematic(s). Pay special attention to the polarity of the wiring to the servo valve and LVDT.
	Servo valve failure	Replace servo valve.
	Hydraulic supply pressure inadequate	Supply pressure must be greater than 1400 psig/9653 kPa (1600 psig/11 032 kPa preferred).
	Trip relay pressure inadequate (hydraulic trip system IGVA)	Trip pressure must be greater than 40 psig (276 kPa) for Low Pressure trip signal units and 340 psig (2344 kPa) for High Pressure trip signal units.
	Trip solenoid voltage inadequate (electric trip system IGVA)	Trip solenoid voltage must be 90–140 Vdc.
	Trip Relay Valve Cartridge failure	Remove the two Trip Relay Valves from the actuator as described previously. Visually inspect and actuate by hand. Check for contamination, sticky operation, or binding. Clean as described in the Maintenance section, or replace the Trip Valves.
Actuator will not close	Servo valve command current incorrect. (The sum of the current through the three coils of the servo valve must be less than the null bias of the servo valve for the actuator to close.)	Trace and verify that all wiring is in accordance with the electrical schematic (Figures 1-12/1-13/1-14) and the GE system wiring schematic(s). Pay special attention to the polarity of the wiring to the servo valve and LVDT.
	Servo valve failure	Replace servo valve.
	LVDT failure	Replace LVDT.
	Linkage broken	Return actuator to Woodward for service.
	Trip Relay Valve Cartridge failure	Remove the two Trip Relay Valves from the actuator as described previously. Visually inspect and actuate by hand. Check for contamination, sticky operation, or binding. Clean as described in the Maintenance section, or replace the Trip Valves.
Actuator will not respond smoothly	Hydraulic filter clogged	Check the differential pressure indicator on the filter housing.

Symptom	Possible Causes	Remedies
	Servo valve spool sticking	Verify hydraulic contamination levels are within recommendations of Chapter 1. The use of dither may improve performance in contaminated systems.
	Servo valve internal pilot filter clogged	Replace servo valve.
	Rod-end(s) worn out	Return actuator to Woodward for service.
	Piston seal worn out	Return actuator to Woodward for service.
	Trip Relay Valve Cartridge failure	Remove the two Trip Relay Valves from the actuator as described previously. Visually inspect and actuate by hand. Check for contamination, sticky operation, or binding. Clean as described in the Maintenance section, or replace the Trip Valves.
Actuator seals wear out prematurely	Hydraulic contamination level is excessive	Verify hydraulic contamination levels are within recommendations of Chapter 1. The use of excessive dither may reduce life in contaminated systems.
	System is oscillating (seal life is proportional to distance traveled). Even small oscillations (on the order of $\pm 1\%$) at slow frequencies (on the order of 0.1 Hz) cause wear to accumulate rapidly.	Determine and eliminate the root cause of oscillation.

Chapter 6.

Product Support and Service Options

Product Support Options

If you are experiencing problems with the installation, or unsatisfactory performance of a Woodward product, the following options are available:

- Consult the troubleshooting guide in the manual.
- Contact the manufacturer or packager of your system.
- Contact the Woodward Full Service Distributor serving your area.
- Contact Woodward technical assistance (see “How to Contact Woodward” later in this chapter) and discuss your problem. In many cases, your problem can be resolved over the phone. If not, you can select which course of action to pursue based on the available services listed in this chapter.

OEM or Packager Support: Many Woodward controls and control devices are installed into the equipment system and programmed by an Original Equipment Manufacturer (OEM) or Equipment Packager at their factory. In some cases, the programming is password-protected by the OEM or packager, and they are the best source for product service and support. Warranty service for Woodward products shipped with an equipment system should also be handled through the OEM or Packager. Please review your equipment system documentation for details.

Woodward Business Partner Support: Woodward works with and supports a global network of independent business partners whose mission is to serve the users of Woodward controls, as described here:

- A **Full Service Distributor** has the primary responsibility for sales, service, system integration solutions, technical desk support, and aftermarket marketing of standard Woodward products within a specific geographic area and market segment.
- An **Authorized Independent Service Facility (AISF)** provides authorized service that includes repairs, repair parts, and warranty service on Woodward's behalf. Service (not new unit sales) is an AISF's primary mission.

A current list of Woodward Business Partners is available at:

<https://www.woodward.com/en/support/industrial/service-and-spare-parts/find-a-local-partner>

Product Service Options

The following factory options for servicing Woodward products are available through your local Full-Service Distributor or the OEM or Packager of the equipment system, based on the standard Woodward Product and Service Warranty (Woodward North American Terms and Conditions of Sale 5-09-0690) that is in effect at the time the product is originally shipped from Woodward or a service is performed:

- Replacement/Exchange (24-hour service)
- Flat Rate Repair
- Flat Rate Remanufacture

Replacement/Exchange: Replacement/Exchange is a premium program designed for the user who is in need of immediate service. It allows you to request and receive a like-new replacement unit in minimum time (usually within 24 hours of the request), providing a suitable unit is available at the time of the request, thereby minimizing costly downtime. This is a flat-rate program and includes the full standard Woodward product warranty (Woodward North American Terms and Conditions of Sale 5-09-0690).

This option allows you to call your Full-Service Distributor in the event of an unexpected outage, or in advance of a scheduled outage, to request a replacement control unit. If the unit is available at the time of the call, it can usually be shipped out within 24 hours. You replace your field control unit with the like-new replacement and return the field unit to the Full-Service Distributor.

Charges for the Replacement/Exchange service are based on a flat rate plus shipping expenses. You are invoiced the flat rate replacement/exchange charge plus a core charge at the time the replacement unit is shipped. If the core (field unit) is returned within 60 days, a credit for the core charge will be issued.

Flat Rate Repair: Flat Rate Repair is available for the majority of standard products in the field. This program offers you repair service for your products with the advantage of knowing in advance what the cost will be. All repair work carries the standard Woodward service warranty (Woodward North American Terms and Conditions of Sale 5-09-0690) on replaced parts and labor.

Flat Rate Remanufacture: Flat Rate Remanufacture is very similar to the Flat Rate Repair option with the exception that the unit will be returned to you in "like-new" condition and carry with it the full standard Woodward product warranty (Woodward North American Terms and Conditions of Sale 5-09-0690). This option is applicable to mechanical products only.

Returning Equipment for Repair

If a control (or any part of an electronic control) is to be returned for repair, please contact your Full-Service Distributor in advance to obtain Return Authorization and shipping instructions.

When shipping the item(s), attach a tag with the following information:

- Return authorization number
- Name and location where the control is installed
- Name and phone number of contact person
- Complete Woodward part number(s) and serial number(s)
- Description of the problem
- Instructions describing the desired type of repair

Packing a Control

Use the following materials when returning a complete control:

- Protective caps on any connectors
- Antistatic protective bags on all electronic modules
- Packing materials that will not damage the surface of the unit
- At least 100 mm (4 inches) of tightly packed, industry-approved packing material
- A packing carton with double walls
- A strong tape around the outside of the carton for increased strength

NOTICE

To prevent damage to electronic components caused by improper handling, read and observe the precautions in Woodward manual 82715, *Guide for Handling and Protection of Electronic Controls, Printed Circuit Boards, and Modules*.

Replacement Parts

When ordering replacement parts for controls, include the following information:

- The part number(s) (XXXX-XXXX) that is on the enclosure nameplate
- The unit serial number, which is also on the nameplate

Engineering Services

Woodward offers various Engineering Services for our products. For these services, you can contact us by telephone, by email, or through the Woodward website.

- Technical Support
- Product Training
- Field Service

Technical Support is available from your equipment system supplier, your local Full-Service Distributor, or from many of Woodward's worldwide locations, depending upon the product and application. This service can assist you with technical questions or problem solving during the normal business hours of the Woodward location you contact. Emergency assistance is also available during non-business hours by phoning Woodward and stating the urgency of your problem.

Product Training is available as standard classes at many of our worldwide locations. We also offer customized classes, which can be tailored to your needs and can be held at one of our locations or at your site. This training, conducted by experienced personnel, will assure that you will be able to maintain system reliability and availability.

Field Service engineering on-site support is available, depending on the product and location, from many of our worldwide locations or from one of our Full-Service Distributors. The field engineers are experienced both on Woodward products as well as on much of the non-Woodward equipment with which our products interface.

For information on these services, please contact one of the Full-Service Distributors listed at:

<https://www.woodward.com/en/support/industrial/service-and-spare-parts/find-a-local-partner>

Contacting Woodward's Support Organization

For the name of your nearest Woodward Full-Service Distributor or service facility, please consult our worldwide directory at <https://www.woodward.com/support>, which also contains the most current product support and contact information.

You can also contact the Woodward Customer Service Department at one of the following Woodward facilities to obtain the address and phone number of the nearest facility at which you can receive information and service.

Products Used in Electrical Power Systems	
<u>Facility</u>	<u>Phone Number</u>
Brazil	+55 (19) 3708 4800
China	+86 (512) 8818 5515
Germany	+49 (711) 78954-510
India	+91 (124) 4399500
Japan	+81 (43) 213-2191
Korea	+82 (51) 636-7080
Poland	+48 (12) 295 13 00
United States	+1 (970) 482-5811

Products Used in Engine Systems	
<u>Facility</u>	<u>Phone Number</u>
Brazil	+55 (19) 3708 4800
China	+86 (512) 8818 5515
Germany	+49 (711) 78954-510
India	+91 (124) 4399500
Japan	+81 (43) 213-2191
Korea	+82 (51) 636-7080
United States	+1 (970) 482-5811

Products Used in Industrial Turbomachinery Systems	
<u>Facility</u>	<u>Phone Number</u>
Brazil	+55 (19) 3708 4800
China	+86 (512) 8818 5515
India	+91 (124) 4399500
Japan	+81 (43) 213-2191
Korea	+ 82 (51) 636-7080
Poland	+48 (12) 295 13 00
United States	+1 (970) 482-5811

Technical Assistance

If you need to contact technical assistance, you will need to provide the following information. Please write it down here before contacting the Engine OEM, the Packager, a Woodward Business Partner, or the Woodward factory:

General

Your Name _____

Site Location _____

Phone Number _____

Fax Number _____

Prime Mover Information

Manufacturer _____

Turbine Model Number _____

Type of Fuel (gas, steam, etc.) _____

Power Output Rating _____

Application (power generation, marine,
etc.) _____

Control/Governor Information

Control/Governor #1

Woodward Part Number & Rev. Letter _____

Control Description or Governor Type _____

Serial Number _____

Control/Governor #2

Woodward Part Number & Rev. Letter _____

Control Description or Governor Type _____

Serial Number _____

Control/Governor #3

Woodward Part Number & Rev. Letter _____

Control Description or Governor Type _____

Serial Number _____

Symptoms

Description _____

If you have an electronic or programmable control, please have the adjustment setting positions or the menu settings written down and with you at the time of the call.

Revision History

Changes in Revision Y—

- Updated EU DoC

Changes in Revision W—

- Updated IECEx in Regulatory Compliance and Special Conditions of Safe Use

Changes in Revision V—

- Corrected Figure 1-15 to remove diode

Changes in Revision U—

- Updated figures for enhanced quality: 1-1c, 1-3b, 1-3c, 1-4a, 1-8a, 1-9a, 1-9b, 1-9c.

Changes in Revision T—

- Updated ATEX, EMC, and PED Directives in the Regulatory Compliance section
- Added RoHS Directive to the Regulatory Compliance section
- Updated the Special Conditions for Safe Use section within Regulatory Compliance section
- Added Figures 1-6a, 1-6b, and 1-6c 180 Deg LVDT Orientation
- Replaced the Declarations

Changes to Revision R—

- Updated the Declaration of Conformity

Changes in Revision P—

- Added new top level 9904-3181 to Tables 1-1, 1-2, 1-4 and Turbine Frame table on page 50

Changes in Revision N—

- Updated IECEx compliance information

Changes in Revision M—

- Updated Compliance information
- Added cleaning warning to Chapter 5 Maintenance section
- Added new Declarations

Changes in Revision L—

- Updated Regulatory Compliance information to latest, including IECEx and GOST R

Declarations

EU DECLARATION OF CONFORMITY

EU DoC No.: 00212-04-EU-02-03
Manufacturer's Name: WOODWARD INC.
Manufacturer's Contact Address: 1041 Woodward Way
 Fort Collins, CO 80524 USA
Model Name(s)/Number(s): Inlet Guide Vane (IGV) Actuator with electrical connectors: 9904-533
 and similar
The object of the declaration described above is in conformity with the following relevant Union harmonization legislation: Directive 2014/34/EU on the harmonisation of the laws of the Member States relating to equipment and protective systems intended for use in potentially explosive atmospheres
Markings in addition to CE marking:  II 3 G, Ex nA IIC T3 Gc
Applicable Standards: EN 60079-0:2018 - Explosive atmospheres - Part 0: Equipment - General requirements
 EN 60079-15:2010 - Explosive atmospheres -- Part 15: Equipment protection by type of protection "n"

This declaration of conformity is issued under the sole responsibility of the manufacturer
 We, the undersigned, hereby declare that the equipment specified above conforms to the above Directive(s).

MANUFACTURER

Signature

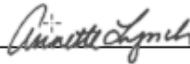

Full Name

Annette Lynch

Position

Engineering Manager

Place

Woodward, Fort Collins, CO, USA

Date

18 July, 2022

5-09-1183 Rev 38

EU DECLARATION OF CONFORMITY

EU DoC No.: 00212-04-EU-02-02
Manufacturer's Name: WOODWARD INC.

Manufacturer's Contact Address: 1041 Woodward Way
Fort Collins, CO 80524 USA

Model Name(s): Inlet Guide Vane (IGV) Actuator with junction box and rigid conduit connections.

The object of the declaration described above is in conformity with the following relevant Union harmonization legislation: Directive 2014/34/EU of the European Parliament and of the Council of 26 February 2014 on the harmonization of the laws of the Member States relating to equipment and protective systems intended for use in potentially explosive atmospheres

Markings in addition to CE marking:  II 3 G, Ex ec IIC T3 Gc

Applicable Standards: EN IEC 60079-0:2018 - Electrical apparatus for explosive gas atmospheres – Part 0: General Requirements

EN IEC 60079-7:2015/A1: 2018 - Explosive Atmospheres – Part 7: Equipment protection by increased safety “e”

This declaration of conformity is issued under the sole responsibility of the manufacturer
We, the undersigned, hereby declare that the equipment specified above conforms to the above Directive(s).

MANUFACTURER

Signature 

Full Name Annette Lynch

Position Engineering Manager

Place Woodward, Fort Collins, CO, USA

Date 24 March 2026

**DECLARATION OF INCORPORATION
Of Partly Completed Machinery
2006/42/EC**

File name: 00212-04-EU-02-01
Manufacturer's Name: WOODWARD INC.
Manufacturer's Address: 1041 Woodward Way.
 Fort Collins, CO, 80524 USA
Model Names: Inlet Guide Vane (IGV) Actuators

This product complies, where applicable, with the following Essential Requirements of Annex I: 1.1, 1.2, 1.3, 1.4, 1.5, 1.6, 1.7



The relevant technical documentation is compiled in accordance with part B of Annex VII. Woodward shall transmit relevant information if required by a reasoned request by the national authorities. The method of transmittal shall be agreed upon by the applicable parties.

The person authorized to compile the technical documentation:

Name: Dominik Kania, Managing Director
Address: Woodward Poland Sp. z o.o., ul. Skarbowa 32, 32-005 Niepolomice, Poland

This product must not be put into service until the final machinery into which it is to be incorporated has been declared in conformity with the provisions of this Directive, where appropriate.

The undersigned hereby declares, on behalf of Woodward Governor Company of Loveland and Fort Collins, Colorado that the above referenced product is in conformity with Directive 2006/42/EC as partly completed machinery:

MANUFACTURER



 Signature

 Christopher Perkins
 Full Name

 Engineering Manager
 Position

 Woodward Inc., Fort Collins, CO, USA
 Place

 03-MAY-2016
 Date

We appreciate your comments about the content of our publications.

Send comments to: industrial.support@woodward.com

Please reference publication **26188**.



PO Box 1519, Fort Collins CO 80522-1519, USA
1041 Woodward Way, Fort Collins CO 80524, USA
Phone +1 (970) 482-5811

Email and Website—www.woodward.com

Woodward has company-owned plants, subsidiaries, and branches, as well as authorized distributors and other authorized service and sales facilities throughout the world.

Complete address / phone / fax / email information for all locations is available on our website.