





**Product Manual 26620**  
**(Revision K, 10/2025)**  
Original Instructions





## **Gas Stop/Ratio Valve**

**Installation and Operation Manual**

	Read this entire manual and all other publications pertaining to the work to be performed before installing, operating, or servicing this equipment.
	Practice all plant and safety instructions and precautions.
	Failure to follow instructions can cause personal injury and/or property damage.
<b>General Precautions</b>	

	This publication may have been revised or updated since this copy was produced. The latest version of most publications is available on the Woodward website.
	<a href="#">Woodward Industrial Support: Get Help</a>
	If your publication is not there, please contact your customer service representative to get the latest copy.
<b>Revisions</b>	

	Any unauthorized modifications to or use of this equipment outside its specified mechanical, electrical, or other operating limits may cause personal injury and/or property damage, including damage to the equipment. Any such unauthorized modifications: (i) constitute "misuse" and/or "negligence" within the meaning of the product warranty thereby excluding warranty coverage for any resulting damage, and (ii) invalidate product certifications or listings.
	<b>Proper Use</b>

	If the cover of this publication states "Translation of the Original Instructions" please note:
	The original source of this publication may have been updated since this translation was made. The latest version of most publications is available on the Woodward website.
	<a href="#">Woodward Industrial Support: Get Help</a>
	Always compare with the original for technical specifications and for proper and safe installation and operation procedures.
<b>Translated Publications</b>	If your publication is not on the Woodward website, please contact your customer service representative to get the latest copy.

**Revisions**— A bold, black line alongside the text identifies changes in this publication since the last revision.

Woodward reserves the right to update any portion of this publication at any time. Information provided by Woodward is believed to be correct and reliable. However, no responsibility is assumed by Woodward unless otherwise expressly undertaken.

# Contents

<b>WARNINGS AND NOTICES</b> .....	<b>3</b>
<b>ELECTROSTATIC DISCHARGE AWARENESS</b> .....	<b>4</b>
<b>REGULATORY COMPLIANCE</b> .....	<b>5</b>
<b>CHAPTER 1. GENERAL INFORMATION</b> .....	<b>8</b>
<b>CHAPTER 2. STOP/RATIO VALVE OPERATION</b> .....	<b>32</b>
<b>CHAPTER 3. STANDARD COMPONENT DETAILS</b> .....	<b>33</b>
Trip Relay Valve Assembly .....	33
Hydraulic Filter Assembly .....	33
LVDT Position Feedback Sensors .....	34
<b>CHAPTER 4. INSTALLATION</b> .....	<b>35</b>
General .....	35
Unpacking .....	36
Piping Installation .....	36
Hydraulic Connections .....	37
Electrical Connections .....	37
Fuel Vent Port .....	38
Electronic Settings .....	38
<b>CHAPTER 5. MAINTENANCE AND HARDWARE REPLACEMENT</b> .....	<b>40</b>
Maintenance .....	40
Hardware Replacement .....	40
Troubleshooting Charts .....	46
<b>CHAPTER 6. SAFETY MANAGEMENT – SAFE POSITION FUEL SHUTOFF FUNCTION</b> .....	<b>48</b>
Safety Function .....	48
Product Variations Certified .....	48
SFF (Safe Failure Fraction) for Gas Stop/Ratio Valve – Over Speed SIF .....	48
Response Time Data .....	49
Limitations .....	49
Management of Functional Safety .....	49
Restrictions .....	49
Competence of Personnel .....	49
Operation and Maintenance Practice .....	50
Installation and Site Acceptance Testing .....	50
Functional Testing after Initial Installation .....	50
Functional Testing after Changes .....	50
Proof Test (Functional Test) .....	50
Suggested Proof Test .....	50
Proof Test Coverage .....	51
Terms and Definitions .....	51
Acronyms .....	52
<b>CHAPTER 7. PRODUCT SUPPORT AND SERVICE OPTIONS</b> .....	<b>53</b>
Product Support Options .....	53
Product Service Options .....	53
Returning Equipment for Repair .....	54
Replacement Parts .....	55
Engineering Services .....	55
Contacting Woodward’s Support Organization .....	55
Technical Assistance .....	56
<b>REVISION HISTORY</b> .....	<b>57</b>

DECLARATIONS .....	58
--------------------	----

## Illustrations and Tables

Figure 1-1. Gas Stop/Ratio Valve (typical; 3-inch shown) .....	10
Figure 1-2. Single Acting Hydraulic Schematic.....	11
Figure 1-3a. Electrical Schematic and Wiring Diagram (Dual LVDT) .....	12
Figure 1-3b. Electrical Schematic and Wiring Diagram (Triple LVDT, 6" and 8" valves only) .....	12
Figure 1-4a. LVDT Barrier Wiring Diagram (TIIS requirement, Japan) .....	13
Figure 1-4b. Servo Valve Barrier Wiring Diagram (TIIS requirement, Japan) .....	14
Figure 1-5a. Gas Stop/Ratio Valve Outline Drawing (3-inch) Low Pressure Trip (LPT).....	16
Figure 1-5b. Gas Stop/Ratio Valve Outline Drawing (3-inch) Low Pressure Trip (LPT).....	17
Figure 1-5c. Gas Stop/Ratio Valve Outline Drawing (3-inch) High Pressure Trip (HPT) .....	18
Figure 1-5d. Gas Stop/Ratio Valve Outline Drawing (3-inch) High Pressure Trip (HPT) .....	19
Figure 1-6a. Gas Stop/Ratio Valve Outline Drawing (4-inch) .....	20
Figure 1-6b. Gas Stop/Ratio Valve Outline Drawing (4-inch) .....	21
Figure 1-7a. Gas Stop/Ratio Valve Outline Drawing (6-inch, except SS-260) .....	22
Figure 1-7b. Gas Stop/Ratio Valve Outline Drawing (6-inch, except SS-260) .....	23
Figure 1-8a. Gas Stop/Ratio Valve Outline Drawing (6-inch, SS-260) .....	24
Figure 1-8b. Gas Stop/Ratio Valve Outline Drawing (6-inch, SS-260) .....	25
Figure 1-9a. Gas Stop/Ratio Valve Outline Drawing (6-inch, with 3 LVDTs, SS-260).....	26
Figure 1-9b. Gas Stop/Ratio Valve Outline Drawing (6-inch, with 3 LVDTs, SS-260).....	27
Figure 1-10a. Gas Stop/Ratio Valve Outline Drawing (8-inch, with 2 LVDTs).....	28
Figure 1-10b. Gas Stop/Ratio Valve Outline Drawing (8-inch, with 2 LVDTs).....	29
Figure 1-11a. Gas Stop/Ratio Valve Outline Drawing (8-inch, with 3 LVDTs).....	30
Figure 1-11b. Gas Stop/Ratio Valve Outline Drawing (8-inch, with 3 LVDTs).....	31
Figure 4-1. Stop/Ratio Valve Block Diagram .....	38
Figure 4-2. Structures for PID Control .....	39
Figure 5-1. Aluminum Filter Bowl .....	41
Figure 5-2. Steel Filter Bowl.....	42
Table 4-1. Class 300 Flange Size and Fastener Specifications .....	36
Table 4-2. Bolt Torque Value .....	36
Table 4-3. Recommended Control Gain Values for Different Control Types.....	39
Table 6-1. Failure Rates according to IEC 61508 in FIT .....	49
Table 6-2. Suggested Proof Test .....	50
Table 6-3. Proof Test Coverage.....	51

## Warnings and Notices

### Important Definitions



This is the safety alert symbol used to alert you to potential personal injury hazards. Obey all safety messages that follow this symbol to avoid possible injury or death.

- **DANGER** - Indicates a hazardous situation, which if not avoided, will result in death or serious injury.
- **WARNING** - Indicates a hazardous situation, which if not avoided, could result in death or serious injury.
- **CAUTION** - Indicates a hazardous situation, which if not avoided, could result in minor or moderate injury.
- **NOTICE** - Indicates a hazard that could result in property damage only (including damage to the control).
- **IMPORTANT** - Designates an operating tip or maintenance suggestion.

#### **WARNING**

**Overspeed /  
Overtemperature /  
Overpressure**

The engine, turbine, or other type of prime mover should be equipped with an overspeed shutdown device to protect against runaway or damage to the prime mover with possible personal injury, loss of life, or property damage.

The overspeed shutdown device must be totally independent of the prime mover control system. An overtemperature or overpressure shutdown device may also be needed for safety, as appropriate.

#### **WARNING**

**Personal Protective  
Equipment**

The products described in this publication may present risks that could lead to personal injury, loss of life, or property damage. Always wear the appropriate personal protective equipment (PPE) for the job at hand. Equipment that should be considered includes but is not limited to:

- Eye Protection
- Hearing Protection
- Hard Hat
- Gloves
- Safety Boots
- Respirator

Always read the proper Material Safety Data Sheet (MSDS) for any working fluid(s) and comply with recommended safety equipment.

#### **WARNING**

**Start-up**

Be prepared to make an emergency shutdown when starting the engine, turbine, or other type of prime mover, to protect against runaway or overspeed with possible personal injury, loss of life, or property damage.

## Electrostatic Discharge Awareness

### **NOTICE**

#### **Electrostatic Precautions**

Electronic controls contain static-sensitive parts. Observe the following precautions to prevent damage to these parts:

- Discharge body static before handling the control (with power to the control turned off, contact a grounded surface and maintain contact while handling the control).
- Avoid all plastic, vinyl, and Styrofoam (except antistatic versions) around printed circuit boards.
- Do not touch the components or conductors on a printed circuit board with your hands or with conductive devices.

To prevent damage to electronic components caused by improper handling, read and observe the precautions in Woodward manual **82715**, *Guide for Handling and Protection of Electronic Controls, Printed Circuit Boards, and Modules*.

Follow these precautions when working with or near the control.

1. Avoid the build-up of static electricity on your body by not wearing clothing made of synthetic materials. Wear cotton or cotton-blend materials as much as possible because these do not store static electric charges as much as synthetics.
2. Do not remove the printed circuit board (PCB) from the control cabinet unless absolutely necessary. If you must remove the PCB from the control cabinet, follow these precautions:
  - Do not touch any part of the PCB except the edges.
  - Do not touch the electrical conductors, the connectors, or the components with conductive devices or with your hands.
  - When replacing a PCB, keep the new PCB in the plastic antistatic protective bag it comes in until you are ready to install it. Immediately after removing the old PCB from the control cabinet, place it in the antistatic protective bag.

## Regulatory Compliance

### European Compliance for CE Marking

These listings are limited only to those units bearing the CE Marking.

**EMC Directive:** Declared to Directive 2014/30/EU of the European Parliament and of the Council of 26 February 2014 on the harmonization of the laws of the Member States relating to electromagnetic compatibility (EMC). 2014/30EU is met by evaluation of the physical nature to the EMC protection requirement. Electromagnetically passive or “benign” devices are excluded from the scope of the Directive 2014/30/EU, however they also meet the protection requirement and intent of the directive.

**Pressure Equipment Directive (Fisher Valve):** Certified to Pressure Equipment Directive 2014/68/EU on the harmonization of the laws of the Member States relating to the making available on the market of pressure equipment. Category III, Bureau Veritas CE-0062-PED-H-FVD 001-19-USA, Module H. Fisher Controls International, LLC Declaration of Conformity is provided with each Gas Stop/Ratio Valve

**ATEX Directive:** Directive 2014/34/EU on the harmonisation of the laws of the Member States relating to equipment and protective systems intended for use in potentially explosive atmospheres. See below for special conditions for safe use. Zone 2, Category 3, Group II G, Ex nA IIC T3 Gc

### Other European Compliance:

Compliance with the following European Directives or standards does not qualify this product for application of the CE Marking:

**RoHS Directive:** Restriction of Hazardous Substances 2011/65/EU: Woodward Turbomachinery Systems products are intended exclusively for sale and use only as a part of Large Scale Fixed Installations per the meaning of Art.2.4(e) of directive 2011/65/EU. This fulfills the requirements stated in Art.2.4(c) and as such the product is excluded from the scope of RoHS2.

**ATEX Directive:** Exempt from the non-electrical portion of the ATEX Directive 2014/34/EU due to no potential ignition sources per EN ISO 80079-36:2016 for Zone 2 installation.

**Machinery Directive:** Compliant as partly completed machinery with Directive 2006/42/EC of the European Parliament and the Council of 17 May 2006 on machinery.

**Pressure Equipment Directive (Actuator Portion):** Compliant as “SEP” per Article 4.3 to Pressure Equipment Directive 2014/68/EU on the harmonisation of the laws of the Member States relating to the making available on the market of pressure equipment.

### Other International Compliance

**IECEX:** For IECEx Marked Valves:  
Certified for use in explosive atmospheres per Certificate: IECEx ETL 25.0031X

**TIIS:** Applicable to the servo valve and LVDT. Where customer has requested TIIS compliance, the servo valve and LVDT are TIIS-marked and must be installed with barriers as shown in the Installation Chapter.

**EAC Customs Union**

These listings are limited only to those valves with labels, marking, and manuals in Russian language to comply with their certificates and declaration.

**EAC Customs Union (Marked):** Certified to Technical Regulation CU 012/2011 for use in potentially explosive atmospheres per Certificate RU C-US.MЦ06.B.00084 as 2Ex nA IIC T3 Gc X for electrical and II Gb c T3...T5 for non-electrical portions of the valve.

**EAC Customs Union (Marked):** Certified to Technical Regulation CU 032/2013 On the safety of equipment operating under excessive pressure per Certificate RU C-US.MЮ62.B.01729 – Category 3 valves (6 and 8 inch)

**EAC Customs Union:** Declared to Technical Regulation CU 032/2013 On the safety of equipment operating under excessive pressure. Declaration of Conformity Registration No: RU Д-US. МЮ62.B.01513 - Category 2 valves (3 and 4 inch)

**EAC Customs Union:** Declared to Technical Regulation CU 010/2011 On the safety of machinery and equipment. Declaration of Conformity Registration No: RU Д-US.MЦ06.B.00011.

**North American Compliance**

Suitability for use in North American Hazardous Locations is the result of compliance of the individual components:

**Servo Valve:** FM Certified for Class I, Division 2, Groups A, B, C, D for use in the United States per FM 4B9A6.AX.

CSA Certified for Class I Division 2, Groups A, B, C, D for use in Canada per CSA 1072373.

**Junction Box:** UL Listed for Class I, Zone 1: AEx e II, Ex e II, T6 for use in the United States and Canada per UL E203312.

**LVDT:** CSA Certified for Class I, Divisions 1 and 2, Groups A, B, C, D, T4 for use in the United States and Canada per CSA 151336-1090811

**LVDT (Alternate):** ETL Certified for Class I, Division 2, Groups A, B, C, D, T3 for use in the United States and Canada per ETL J98036083-003.

**SIL Compliance:**

SIL certification is available for specific Woodward item numbers. Please contact a Woodward representative for assistance.



Gas Stop/Ratio Valve – Certified SIL 3 Capable for safe position fuel shutoff function in safety instrumented systems. Evaluated to IEC 61508 Parts 1-7. Refer to the instructions of this Installation and Operation Manual, Chapter 6 – Safety Management – Safe Position Fuel Shutoff Function. SIL Certificate WOO 1905012 C001

**Special Conditions for Safe Use—All Valves**

Wiring must be in accordance with North American Class I, Division 2 or European or other international Zone 2, Category 3 wiring methods as applicable, and in accordance with the authority having jurisdiction.

Field Wiring must be suitable for at least 100°C.

The wiring junction box provides earth ground terminals if needed for a separate earth ground to meet wiring requirements.

T3 reflects conditions without process fluid. The surface temperature of this valve approaches the maximum temperature of the applied process media. It is the responsibility of the user to ensure that the external environment contains no hazardous gases capable of ignition in the range of the process media temperatures.

Compliance with the Machinery Directive 2006/42/EC noise measurement and mitigation requirements is the responsibility of the manufacturer of the machinery into which this product is incorporated.

The risk of electrostatic discharge is reduced by permanent installation of the valve, proper connection of the equipotential ground lugs, and care when cleaning. This device must not be cleaned or wiped off/against unless the area is known to be non-hazardous.

For IECEx Marked Valves:

1. The wiring junction box provides earth ground terminals if needed for a separate earth ground to meet wiring requirements.
2. T3 reflects conditions without process fluid. The surface temperature of this valve approaches the maximum temperature of the applied process media. It is the responsibility of the user to ensure that the external environment contains no hazardous gases capable of ignition in the range of the process media temperatures.
3. The risk of electrostatic discharge is reduced by permanent installation of the valve, proper connection to the protective earth (PE) terminals, and care when cleaning. The valve should not be cleaned unless the area is known to be non-hazardous.
4. The screwed cable connector may only be disconnected when the circuit is de-energized or when the location is known to be non-hazardous.

**WARNING**

**EXPLOSION HAZARD—Do not connect or disconnect while circuit is live unless area is known to be non-hazardous.**

**Substitution of components may impair suitability for Class I, Division 2 or Zone 2.**

**AVERTISSEMENT**

**RISQUE D'EXPLOSION—Ne pas raccorder ni débrancher tant que l'installation est sous tension, sauf en cas l'ambiance est décidément non dangereuse.**

**La substitution de composants peut rendre ce matériel inacceptable pour les emplacements de Classe I, Division 2 ou Zone 2.**

# Chapter 1.

## General Information

The Woodward Gas Stop/Ratio Valve performs a dual function for industrial or utility gas turbines. One function rapidly shuts off fuel to the turbine fuel control system. Another function provides accurate control of gas fuel pressure at the outlet of the stop/ratio valve. This pressure is applied to the inlets of the gas fuel control valve.

The Gas Stop/Ratio Valve features a modular design and meets critical control characteristics while allowing the same valve design to accommodate a variety of stroke, force output, and mechanical interface arrangements. The electrical and mechanical interfaces have been designed for quick and easy assembly or removal of the valve, at the factory or in the field. The components include an on-board hydraulic filter, electrohydraulic servo valve, trip valve, single-acting hydraulic cylinder, and dual LVDTs (the 6" and 8" valves also have the option for triple LVDTs).

Optimum control of the gas turbine requires that the actuator and valve accurately and quickly track the demand signals transmitted by the control. The stop/ratio valve has been designed to provide output forces that exceed the opening and closing requirements with some margin. The additional margin helps ensure that the system moves rapidly even under service conditions where the valve has been contaminated or worn. The hydraulic trip relay valve has been selected to provide high operating force margins, high flow capacity, and to ensure the desired closure rate of the valve under trip conditions.

By using a long actuation rod between the hydraulic cylinder and the valve lever arm, the side-loading forces on the actuator shaft and seals are greatly reduced, decreasing the wear between sliding parts, and increasing the useful service life of the system. The ample distance between the wetted heavy-duty linear slide rings within the stop/ratio valve accommodates any remaining side load. These provisions provide extended service life even in severe service conditions.

### **IMPORTANT**

Units may have either low pressure (LP) or high pressure (HP) trip valves as per the applicable GE ordering drawing. The trip circuit operating pressure is 100 psig (6.9 bar) for LP circuits and 1600 psig (110 bar) for HP circuits.

## Gas Stop/Ratio Valve Functional Characteristics

Functional Requirement	Gas Stop/Ratio Valve																					
Valve Type	Fisher Type Vee-Ball® Design V300 or V300 Series B or V200 Series B Flangeless HD Metal, TCM-Ultra, or SS-260 seals																					
Position Accuracy	±1% full scale (over ±25 °F/±14 °C deviation from calibration)																					
Position Repeatability	±0.5% of point over the range of 10 to 100%																					
Hydraulic Fluid Type	Petroleum Based hydraulic fluids as well as fire resistant hydraulic fluids such as Fyrquel EHC																					
Maximum Operating Hydraulic Supply Pressure	1200 to 1700 psig (8274 to 11 722 kPa) (design at 1600 psig/11 032 kPa)																					
Proof Test Fluid Pressure Level	2550 psig (20 685 kPa) minimum per SAE J214 (Prod Test)																					
Minimum Burst Fluid Pressure	4250 psig (34 475 kPa) minimum per SAE J214																					
Fluid Filtration Required	10–15 µm at 75 Beta																					
Hydraulic Fluid Contamination Level	Per ISO 4406 code 18/16/13 max, code 16/14/11 preferred																					
Hydraulic Fluid Temperature	+80 to +170 °F (+27 to +77 °C)																					
Actuator Ambient Temperature	–20 to +180 °F (–29 to +82 °C)																					
Vibration Test Level	Random 0.01500 gr <sup>2</sup> /Hz from 10 to 40 Hz ramping down to 0.00015 gr <sup>2</sup> /Hz at 500 Hz (1.04 Grms)																					
Shock	Limited to 30 g by servo valve																					
Trip Time	Less than 0.200 seconds (100–0% stroke)																					
Open Slew Time	5 to 95% in 0.500 ±0.15 seconds																					
Close Slew Time	95 to 5% in 0.500 ± 0.15 seconds																					
Trip Pressure (relative to hydraulic return)	Low Pressure Trip Option: Pick up 24 ±6 psid (165 ±41 kPa) Drop out 22 ±6 psid (152 ±41 kPa)  High Pressure Trip Option: Pick up 750 ±100 psig (5171 ±690 kPa) Drop out 750 ±100 psig (5171 ±690 kPa)																					
Hydraulic Fluid Connections	Trip Relay Pressure–1.062-12 UNF straight thread port (–12) Supply Pressure–0.750-16 UNF straight thread port (–8) Return Port–1.312-20 UNF straight thread port (–16)																					
Servo Input Current Rating	–7.2 to +8.8 mA (null bias 0.8 ±0.32 mA)																					
Paint	Two part Epoxy																					
Actuation Forces (opening at 1200 psig/8274 kPa) (closing via spring)	<table style="width: 100%; border-collapse: collapse;"> <thead> <tr> <th></th> <th style="text-align: center;">3, 4, &amp; 6" valves (small actuator<sup>1</sup>)</th> <th style="text-align: center;">6 &amp; 8" valves (large actuator<sup>2</sup>)</th> </tr> </thead> <tbody> <tr> <td>Opening Force</td> <td></td> <td></td> </tr> <tr> <td style="padding-left: 20px;">Fully Extended</td> <td style="text-align: center;">811 lb/3607 N</td> <td style="text-align: center;">1200 lb/5338 N</td> </tr> <tr> <td style="padding-left: 20px;">Fully Retracted</td> <td style="text-align: center;">1581 lb/7032 N</td> <td style="text-align: center;">3085 lb/13 722 N</td> </tr> <tr> <td>Closing Force</td> <td></td> <td></td> </tr> <tr> <td style="padding-left: 20px;">Fully Extended</td> <td style="text-align: center;">2075 lb/9230 N</td> <td style="text-align: center;">4690 lb/20 861 N</td> </tr> <tr> <td style="padding-left: 20px;">Fully Retracted</td> <td style="text-align: center;">1305 lb/5805 N</td> <td style="text-align: center;">2805 lb/12 477 N</td> </tr> </tbody> </table>		3, 4, & 6" valves (small actuator <sup>1</sup> )	6 & 8" valves (large actuator <sup>2</sup> )	Opening Force			Fully Extended	811 lb/3607 N	1200 lb/5338 N	Fully Retracted	1581 lb/7032 N	3085 lb/13 722 N	Closing Force			Fully Extended	2075 lb/9230 N	4690 lb/20 861 N	Fully Retracted	1305 lb/5805 N	2805 lb/12 477 N
	3, 4, & 6" valves (small actuator <sup>1</sup> )	6 & 8" valves (large actuator <sup>2</sup> )																				
Opening Force																						
Fully Extended	811 lb/3607 N	1200 lb/5338 N																				
Fully Retracted	1581 lb/7032 N	3085 lb/13 722 N																				
Closing Force																						
Fully Extended	2075 lb/9230 N	4690 lb/20 861 N																				
Fully Retracted	1305 lb/5805 N	2805 lb/12 477 N																				
Design Availability Objective	Better than 99.5% over an 8760 hour period																					
Sound Level	Per Fisher-Rosemount Catalog 12																					

<sup>1</sup>Small actuator used on 3", 4", and 6" valves with HD Metal or TCM-Ultra seals

<sup>2</sup>Large actuator used on 6" valves with SS-260 seals, as well as on 8" valves with HD Metal or TCM-Ultra seals

**Note:** Vee-Ball® is a trademark of Fisher-Rosemount.

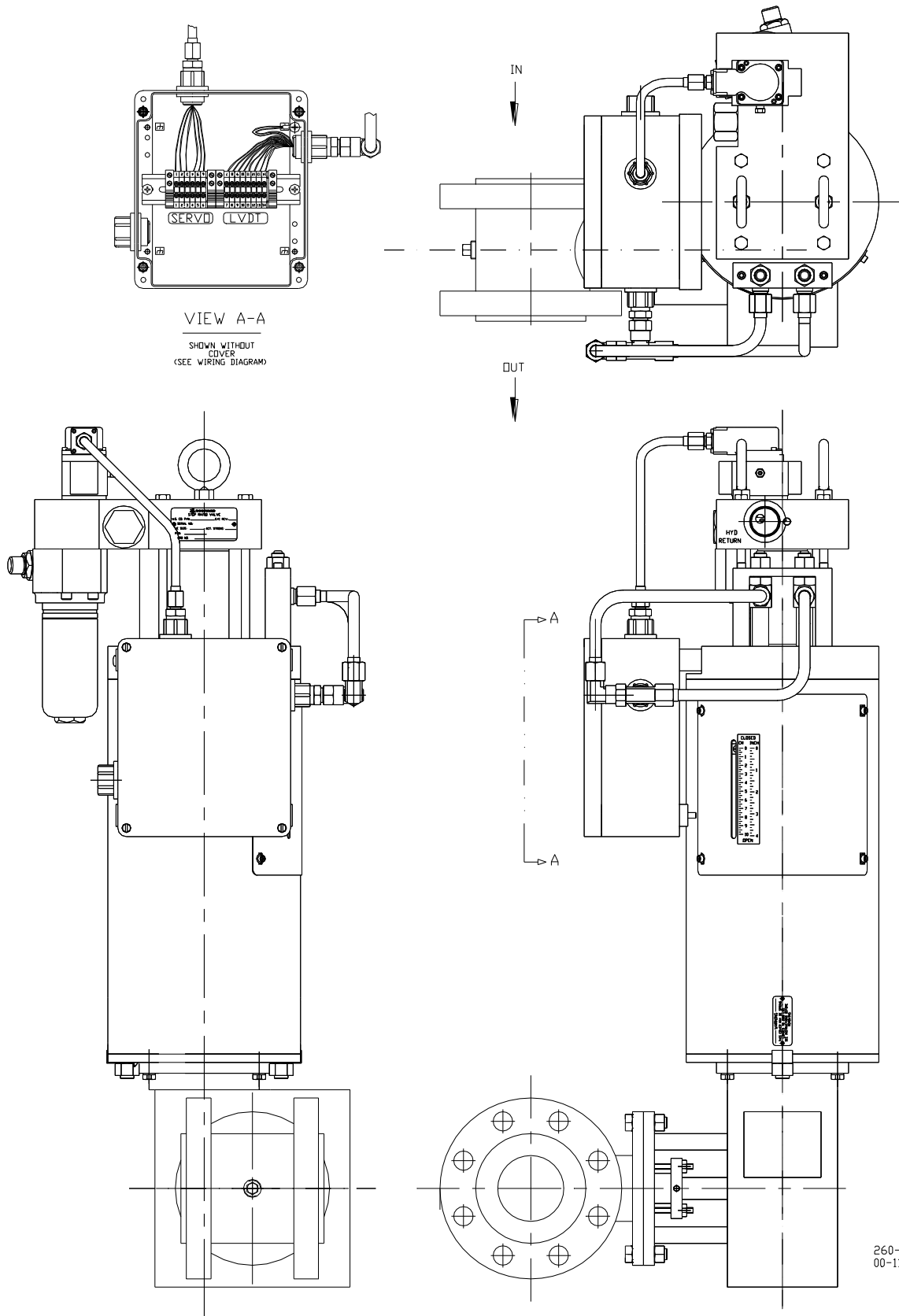

260-072  
00-11-29

Figure 1-1. Gas Stop/Ratio Valve (typical; 3-inch shown)

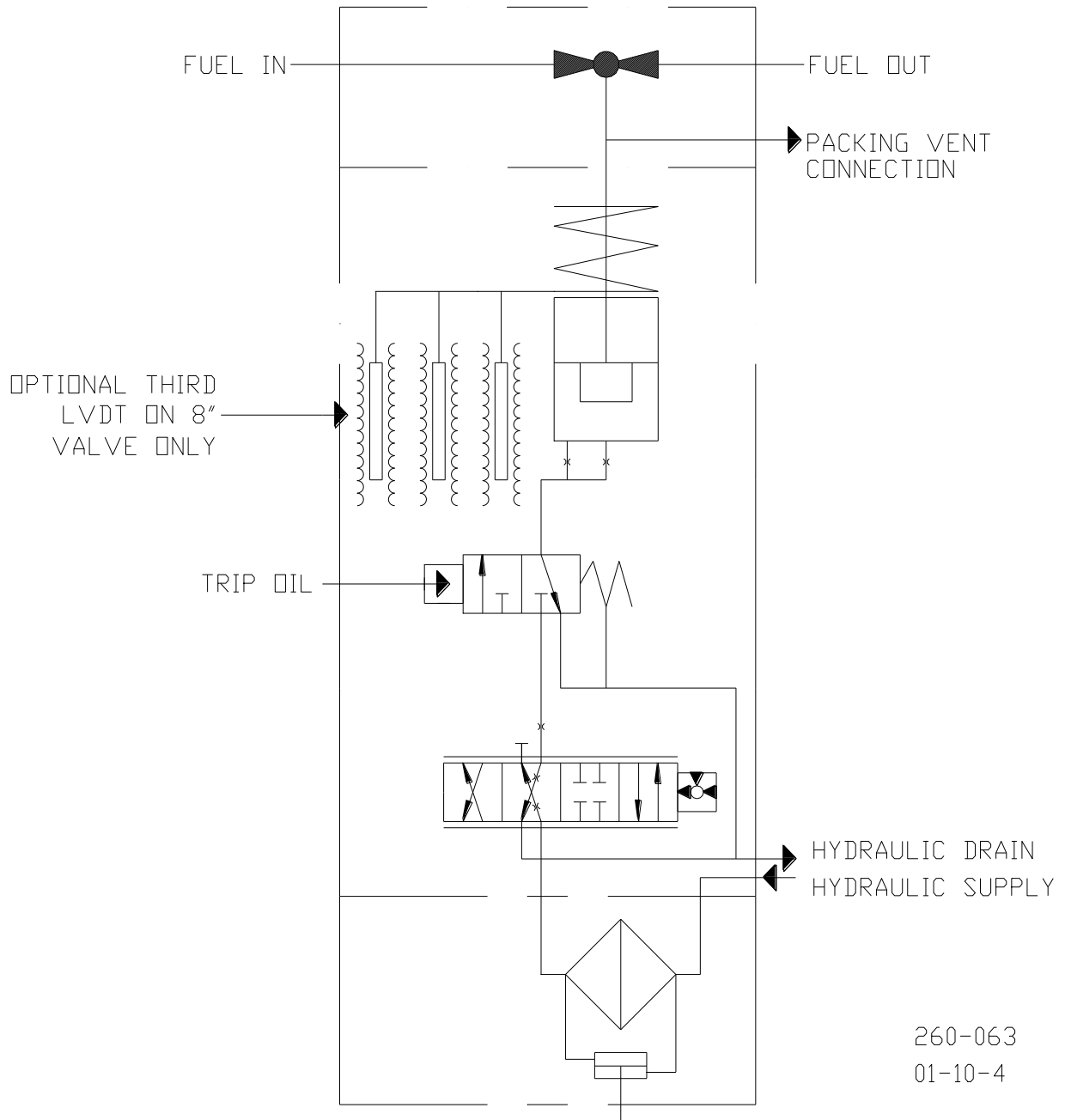

260-063  
01-10-4

Figure 1-2. Single Acting Hydraulic Schematic

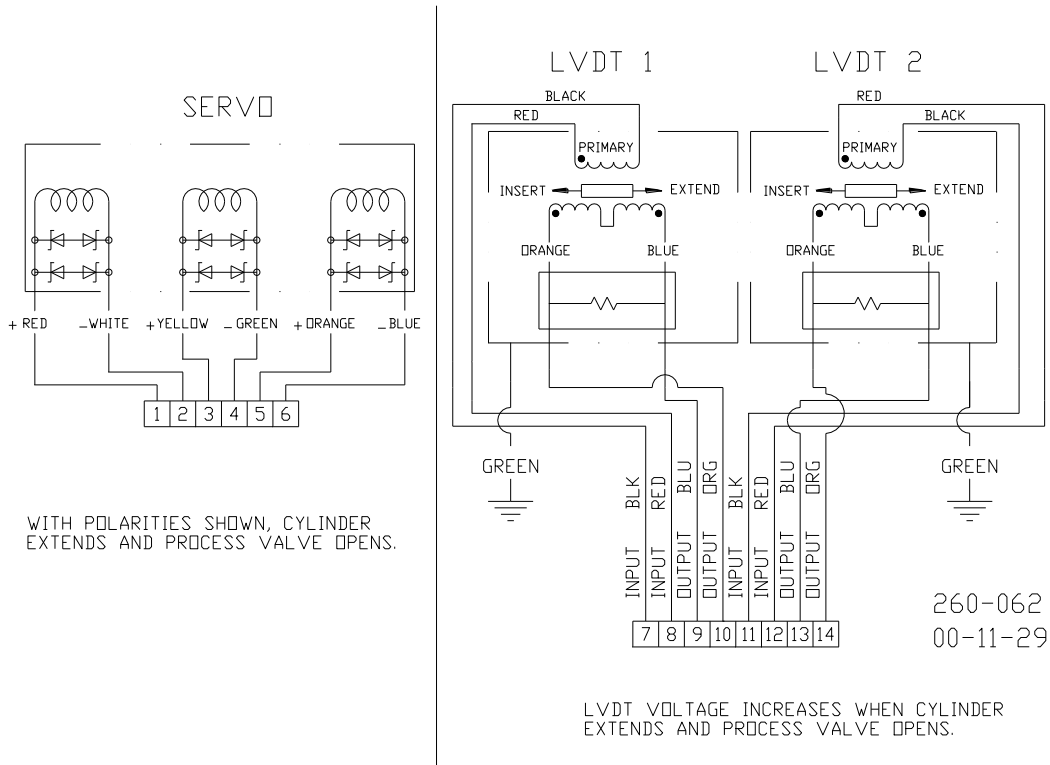

Figure 1-3a. Electrical Schematic and Wiring Diagram (Dual LVDT)

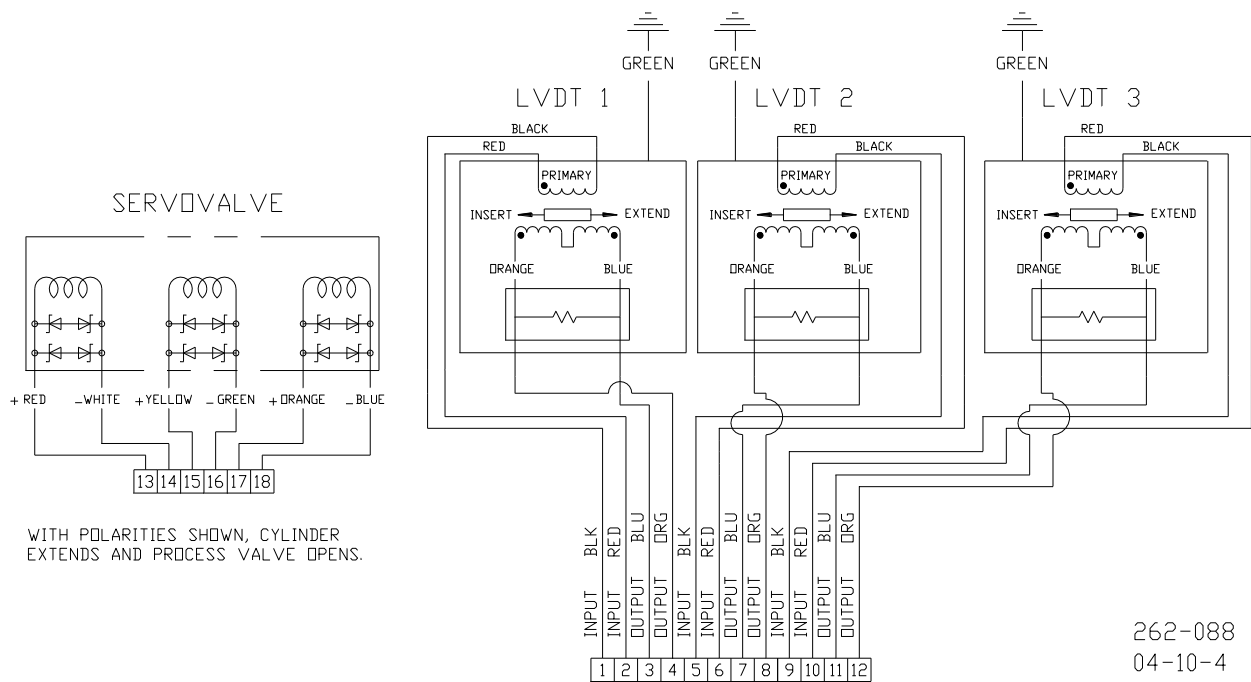
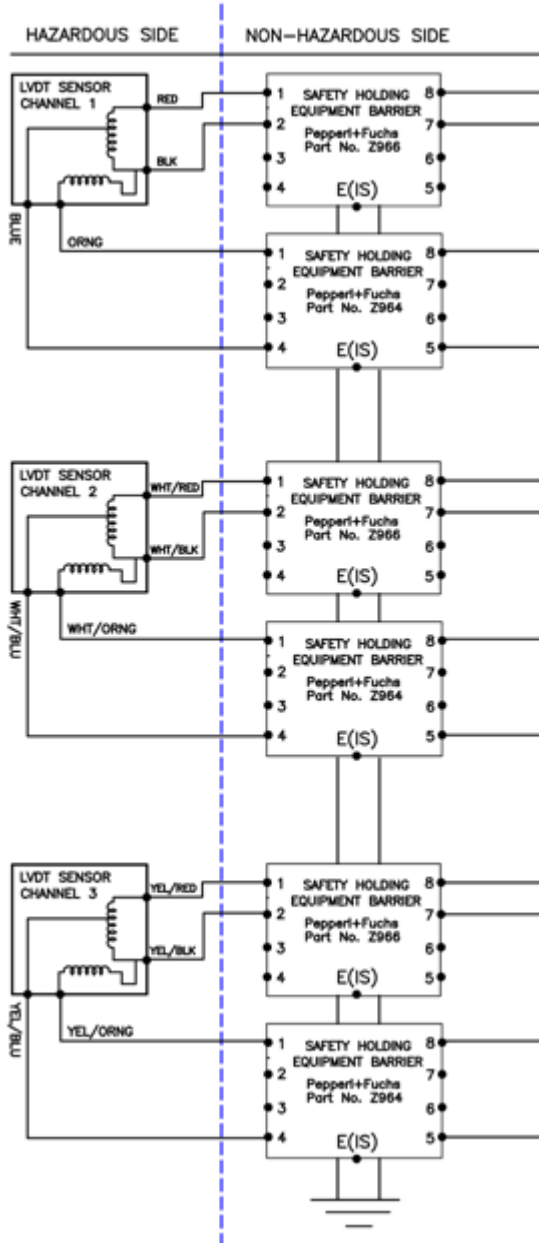

Figure 1-3b. Electrical Schematic and Wiring Diagram (Triple LVDT, 6" and 8" valves only)

LVDT Sensor is used as shown below:



#### NOTES:

- All barriers must be mounted and installed in compliance with the barrier manufacturer's requirement. P+F barriers are by Pepperl+Fuchs GmbH
  - Barrier board: Part No. Z966  
 TIIS Certification No.: TC15714  
 Certification to Pepperl+Fuchs GB Ltd. (Oldham, England)  
 Performance Category and Group:  
 Performance category: ia Group: IIC  
 Rating:  
 $U_o = 12\text{ V}$   $C_o = 1.41\text{ }\mu\text{F}$   
 $I_o = 82\text{ ma}$   $L_o = 5.52\text{ mH}$   
 $P_o = 0.24\text{ W}$
  - Barrier board: Part No. Z964  
 TIIS Certification No.: TC15713  
 Certification to Pepperl+Fuchs GB Ltd. (Oldham, England)  
 Performance Category and Group:  
 Performance category: ia Group: IIC  
 Rating:  
 $U_o = 12\text{ V}$   $C_o = 1.41\text{ }\mu\text{F}$   
 $I_o = 12\text{ ma}$   $L_o = 240\text{ mH}$   
 $P_o = 0.04\text{ W}$
- Intrinsic Safe parameters:
 

Primary: $L_i = 0.0\text{ mH}$	$C_i = 0.0\text{ }\mu\text{F}$
Secondary: $L_i = 2.50\text{ mH}$	$C_i = 0.0\text{ }\mu\text{F}$
- Ambient Temperature:  $-20^\circ\text{C} \leq T_{\text{amb}} \leq 60^\circ\text{C}$ .
- E(IS) is the grounding terminal for holding the intrinsically safe explosion protection structure.
- The outer wiring of each channel shall be carried out independently, for multiple channel unit. For single channel unit, this does not apply. For single channel unit, the second and third channels do not exist.
- The input power source and voltages, etc. of the control system supplying the barriers shall not exceed AC 250 V, 50/60 Hz, DC 250 V at both Normal and abnormal conditions.
- This drawing is for three channel LVDT. For two channel unit, ignore Channel 3. For Single Channel unit, ignore Channels 2 and 3.

Figure 1-4a. LVDT Barrier Wiring Diagram (TIIS requirement, Japan)  
 [This figure applies to TIIS requirement for Japan only.]

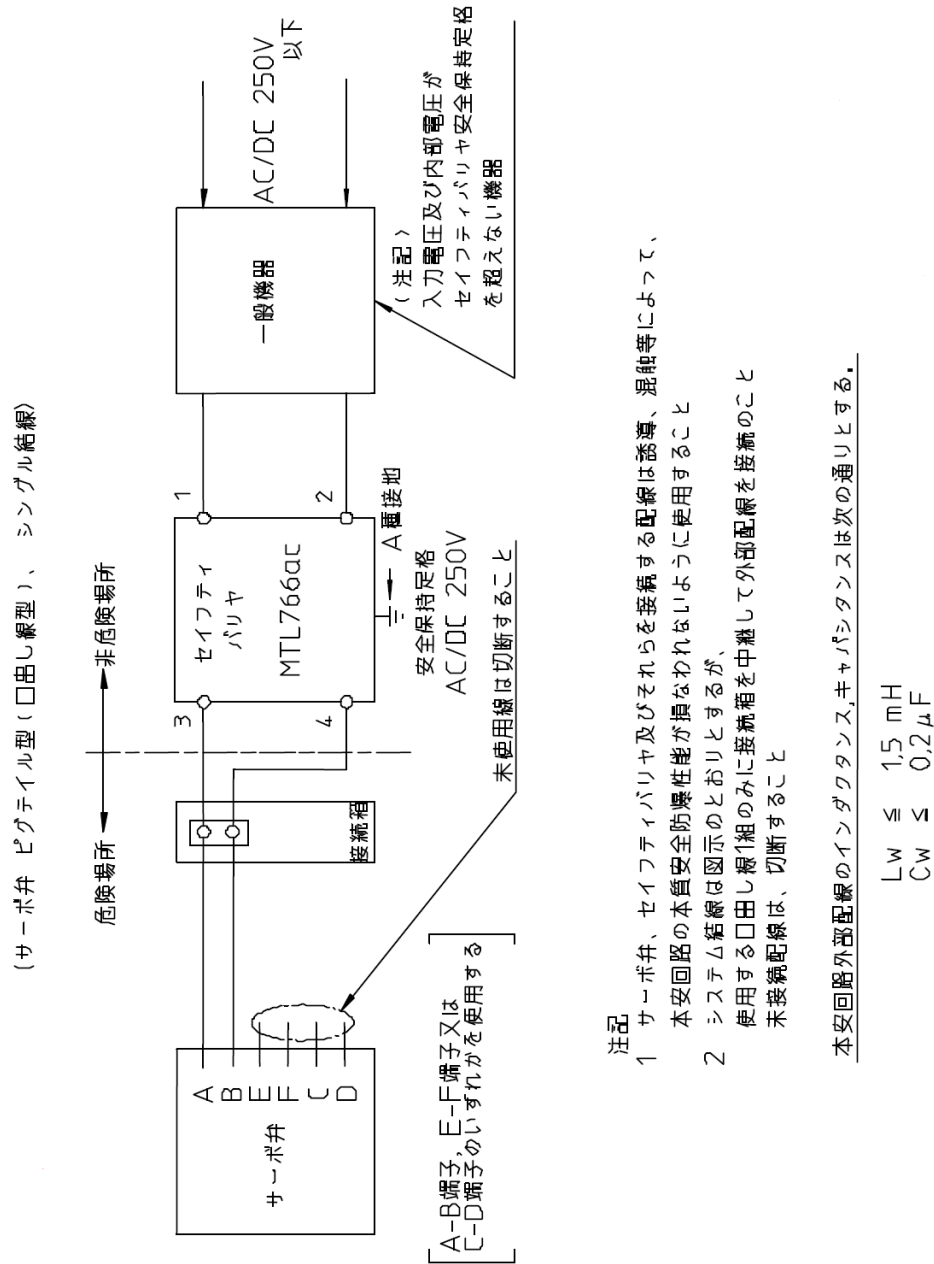

Figure 1-4b. Servo Valve Barrier Wiring Diagram (TIIS requirement, Japan)  
[This figure applies to TIIS requirement for Japan only.]

## Notes for Figures 1-5 through 1-11

1. These general reference outline drawings apply to various Woodward Gas Fuel Stop/Ratio valves. Consult Woodward for the latest outline drawing for your particular stop/ratio valve.
2. Installation Orientation  
Pipe supported only  
Orientation vertical approximately as shown  
See elsewhere in this manual for other installation recommendations
3. Approximate Weight  
3" Valve—255 lbs/116 kg  
4" Valve—280 lbs/127 kg,  
6" Valve (except SS-260)—332 lbs/151 kg  
6" Valve (SS-260)—447 lbs/203 kg  
8" Valve—540 lbs/245 kg
4. Service Manual Replacement Parts  
Servo Valve—consult Woodward for part number  
O-rings for servo valve—consult Woodward for part number  
Filter element—consult Woodward for part number  
Manual—consult Woodward for part number  
LVDT—consult Woodward for part number  
Trip relay valve—consult Woodward for part number  
Seal kit for trip relay valve—consult Woodward for part number
5. Description of Stop/Ratio Valve  
Process fluid                      natural gas  
Temperature range                natural gas 50 to 300 °F/10 to 149 °C (unheated fuel)  
    natural gas 50 to 450 °F/10 to 232 °C (heated fuel)  
    ambient -20 to +180 °F/-29 to +82 °C  
External leakage                 (2 cm<sup>3</sup>/min maximum to overboard drain)
6. Actuation  
Cylinder bore                      Small Actuator<sup>1</sup>: 1.750 inch diameter (44.45 mm)  
    Large Actuator<sup>2</sup>: 2.500 inch diameter (63.50 mm)  
Stroke                                3.500 inch (88.90 mm)  
Static seals                        Elastomer per US MIL-R-83248 (Viton)  
Operating fluid                    Petroleum-based hydraulic fluid as well as fire resistant hydraulic fluids such as  
    Fyrquel EHC  
Rated hydraulic pressure        1600 psig/11 032 kPa  
Operating hydraulic pressure    1200 to 1700 psig/8274 to 11 722 kPa  
Ambient temperature            -20 to +180 °F/-29 to +82 °C  
Hydraulic fluid temperature    80 to 170 °F/27 to 77 °C
7. Servo valve  
Flow rating                         Small Actuator<sup>1</sup>: 5.0 US gal/min (18.9 L/min) at 1000 psid (6895 kPa) valve drop,  
    4-way  
    Large Actuator<sup>2</sup>: 10.0 US gal/min (37.8 L/min) at 1000 psid (6895 kPa) valve drop,  
    4-way  
Electrical input rating         ±8 mA (sum of three coils)  
Null bias                            10% of rated flow to close stop/ratio valve  
    (= 10 ± 4% rated current at hydraulic null)  
Electrical connection         0.375 O.D. tube fitting. 0.562-18 UNF-2A thread per  
    MS 33656-6

<sup>1</sup>Small actuator used on 3", 4", and 6" valves with HD Metal or TCM-Ultra seals

<sup>2</sup>Large actuator used on 6" valves with SS-260 seals, as well as on 8" valves with HD Metal or TCM-Ultra seals

**IMPORTANT**

**These general reference outline drawings apply to various Woodward Gas Fuel Stop/Ratio valves. Consult Woodward for the latest outline drawing for your particular stop/ratio valve.**



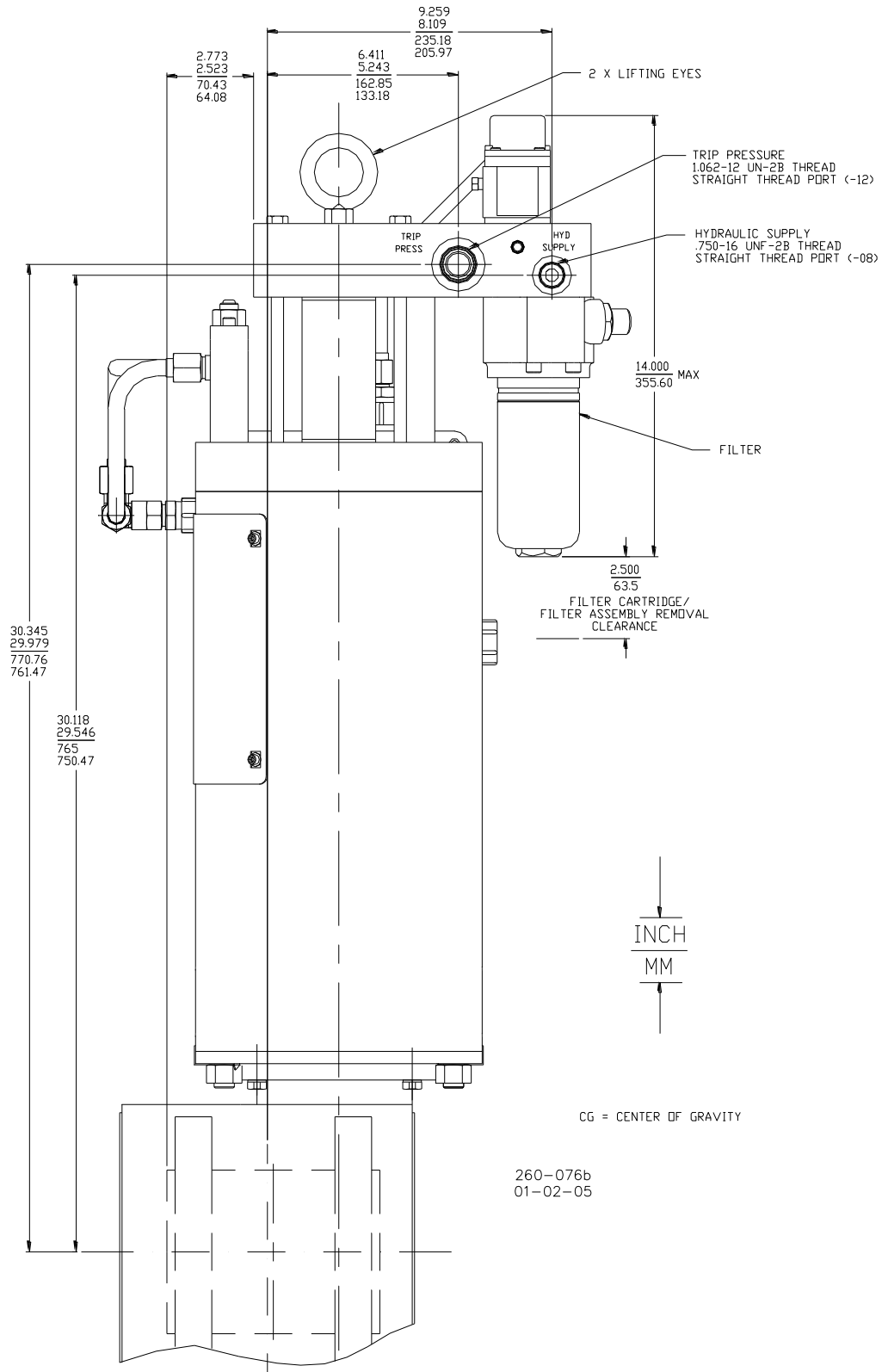

Figure 1-5b. Gas Stop/Ratio Valve Outline Drawing (3-inch)  
Low Pressure Trip (LPT)

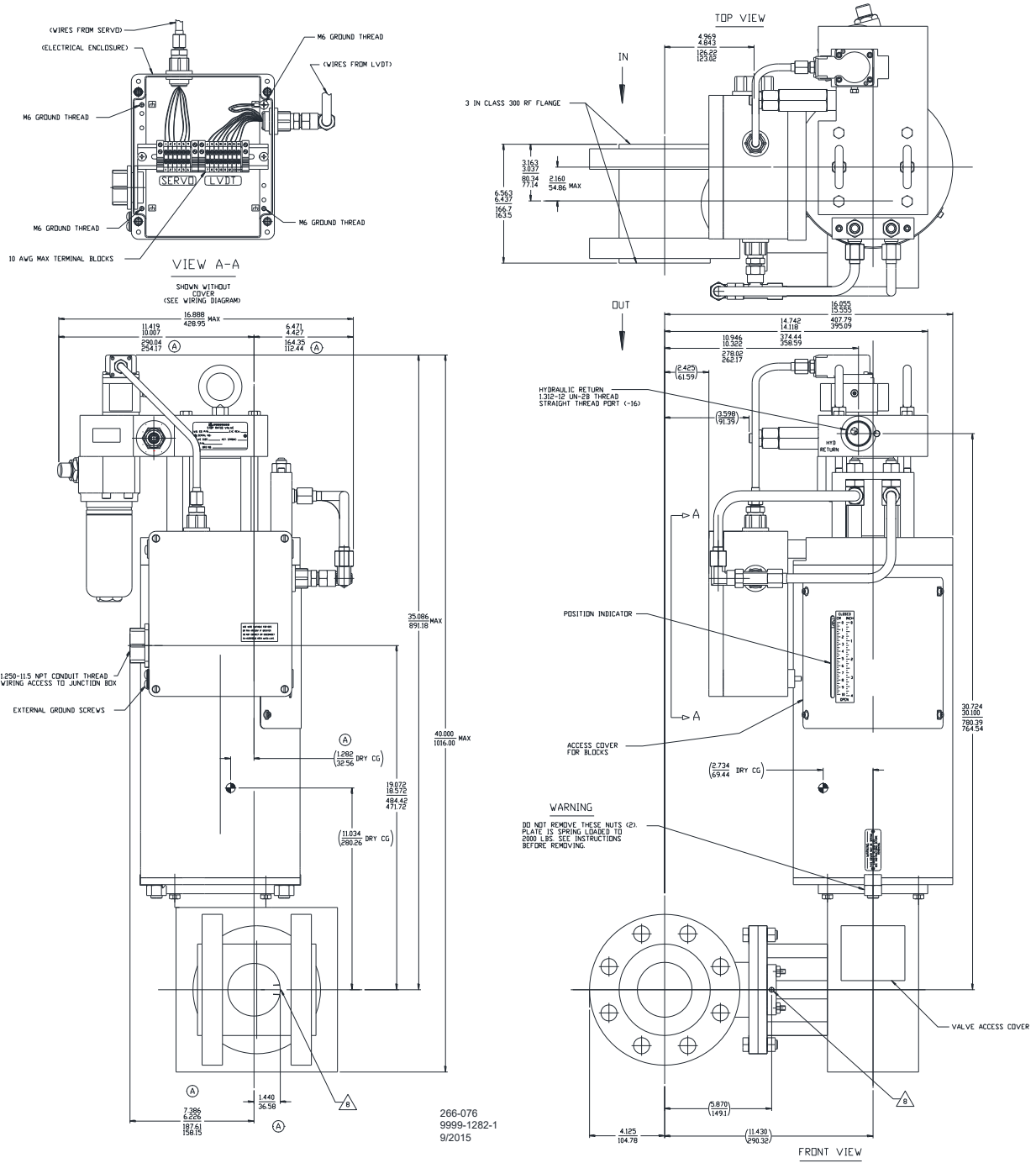

Figure 1-5c. Gas Stop/Ratio Valve Outline Drawing (3-inch) High Pressure Trip (HPT)

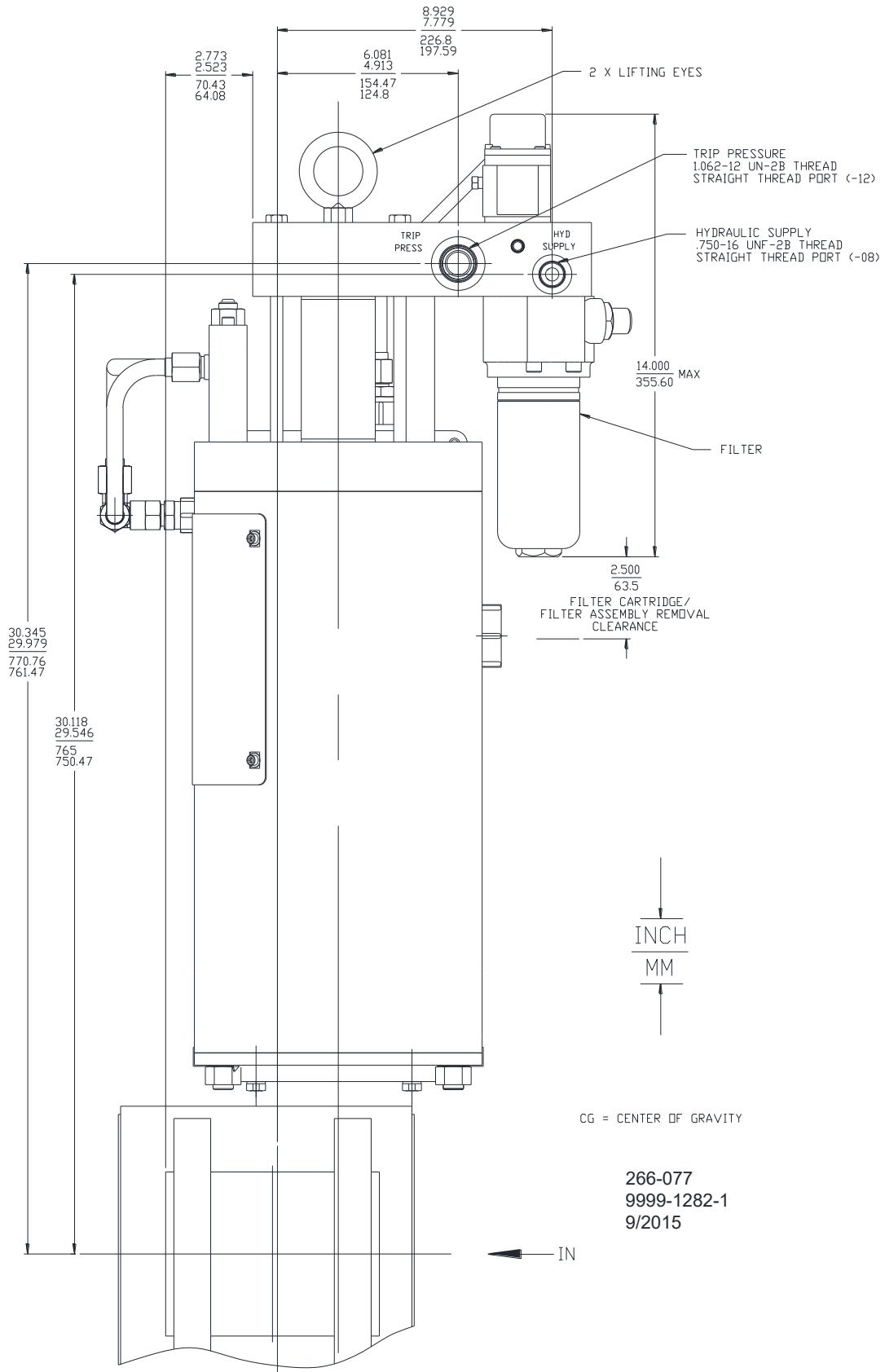

Figure 1-5d. Gas Stop/Ratio Valve Outline Drawing (3-inch High Pressure Trip (HPT))

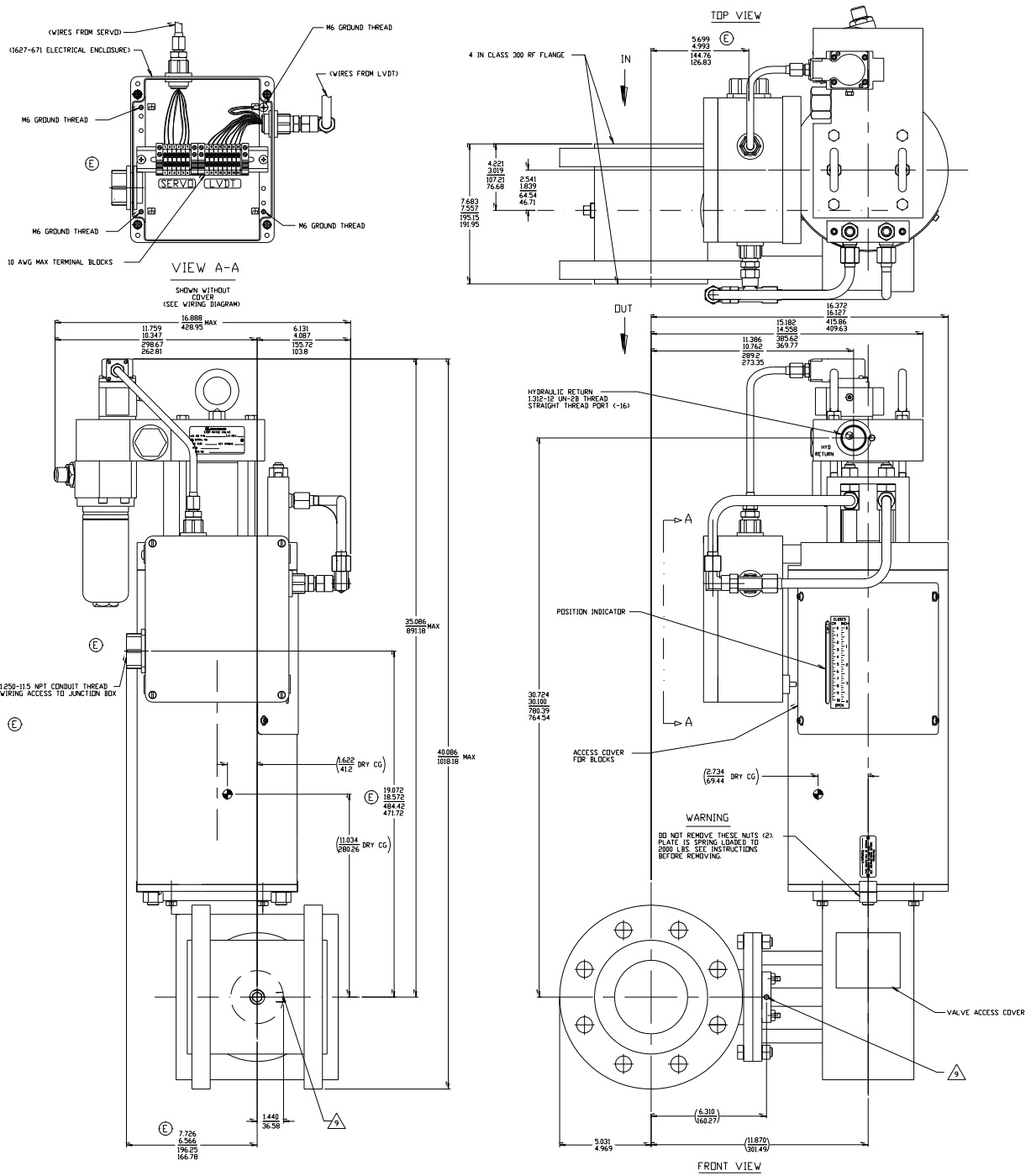

Figure 1-6a. Gas Stop/Ratio Valve Outline Drawing (4-inch)

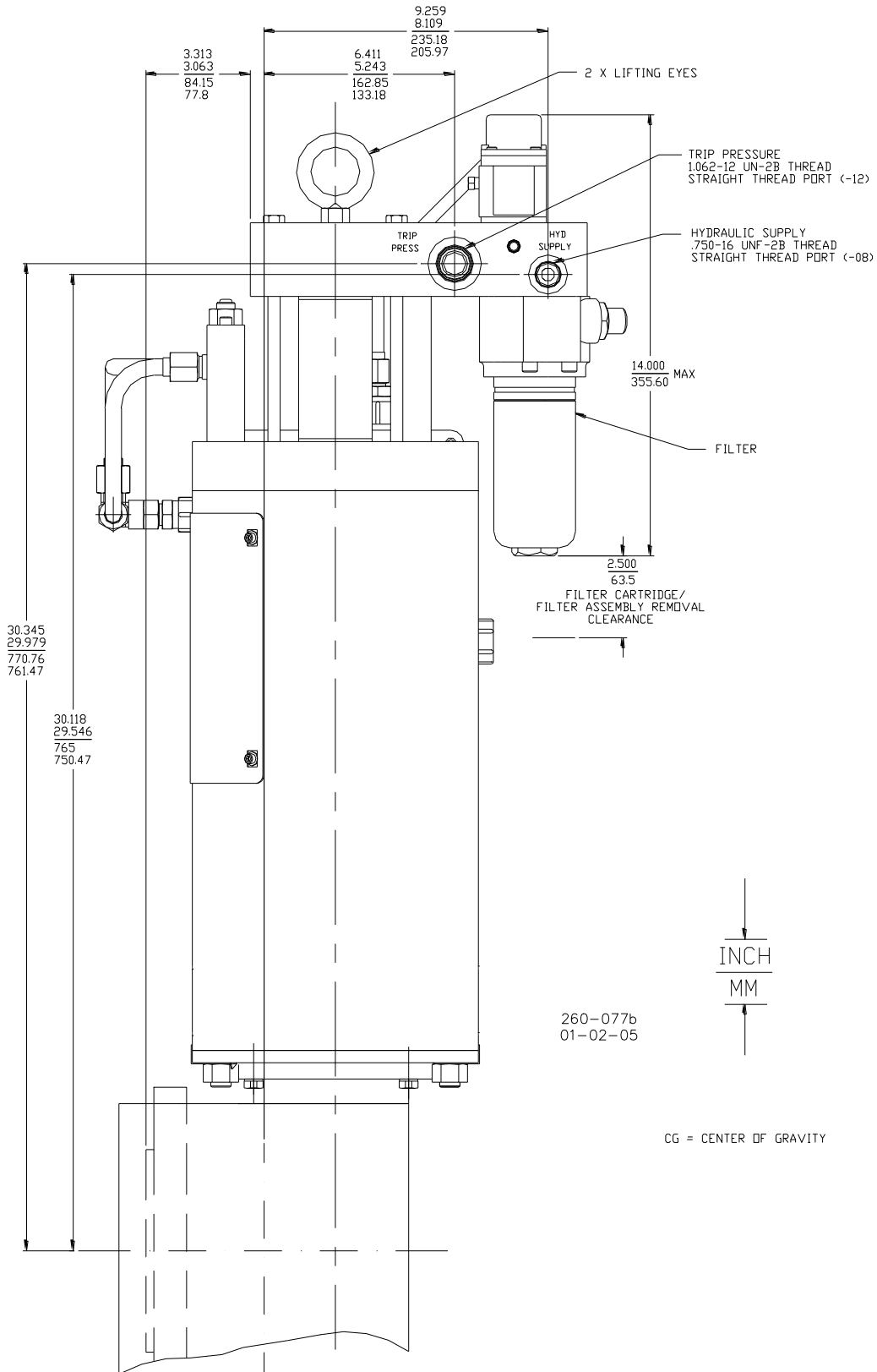

Figure 1-6b. Gas Stop/Ratio Valve Outline Drawing (4-inch)

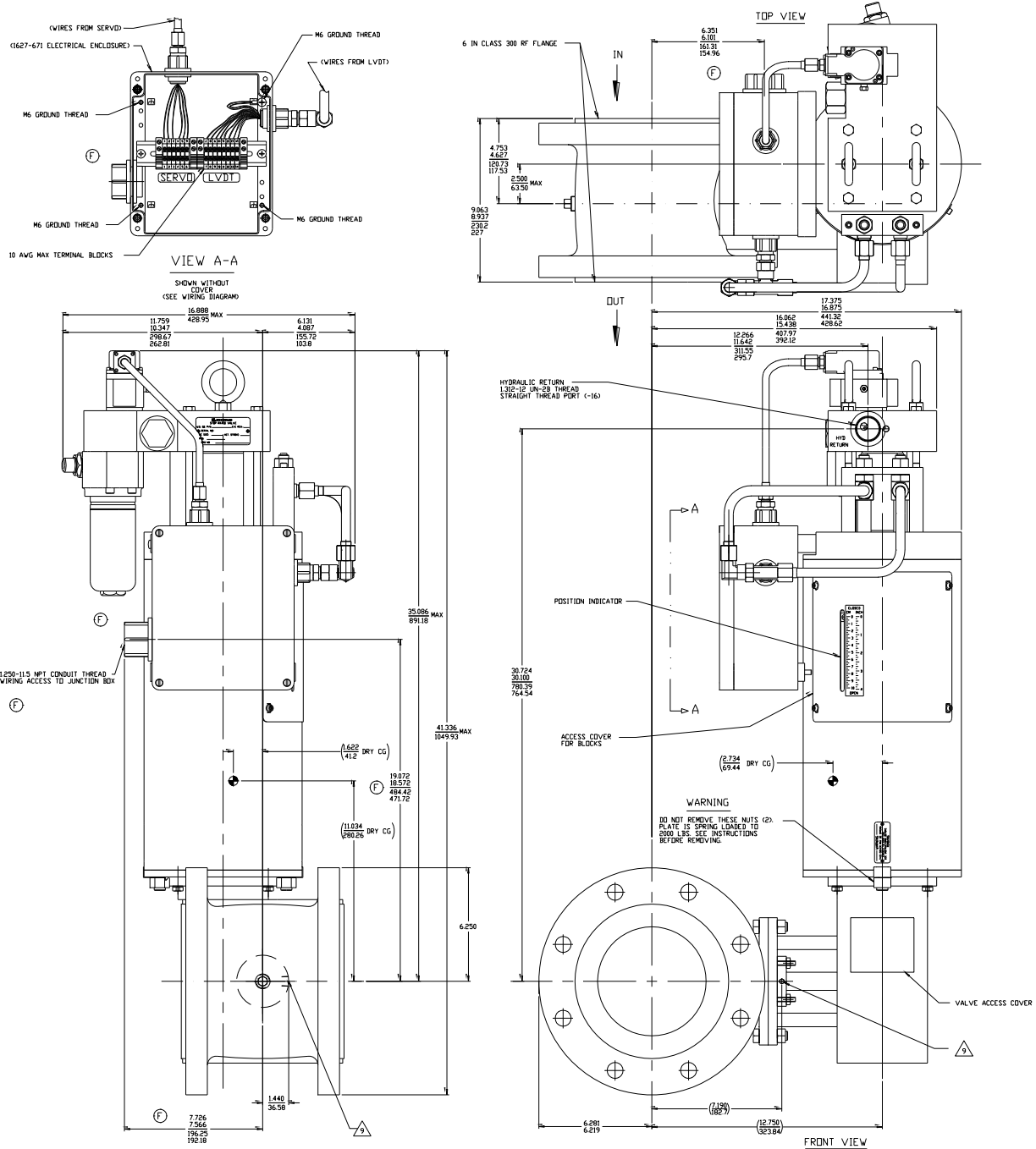

Figure 1-7a. Gas Stop/Ratio Valve Outline Drawing (6-inch, except SS-260)

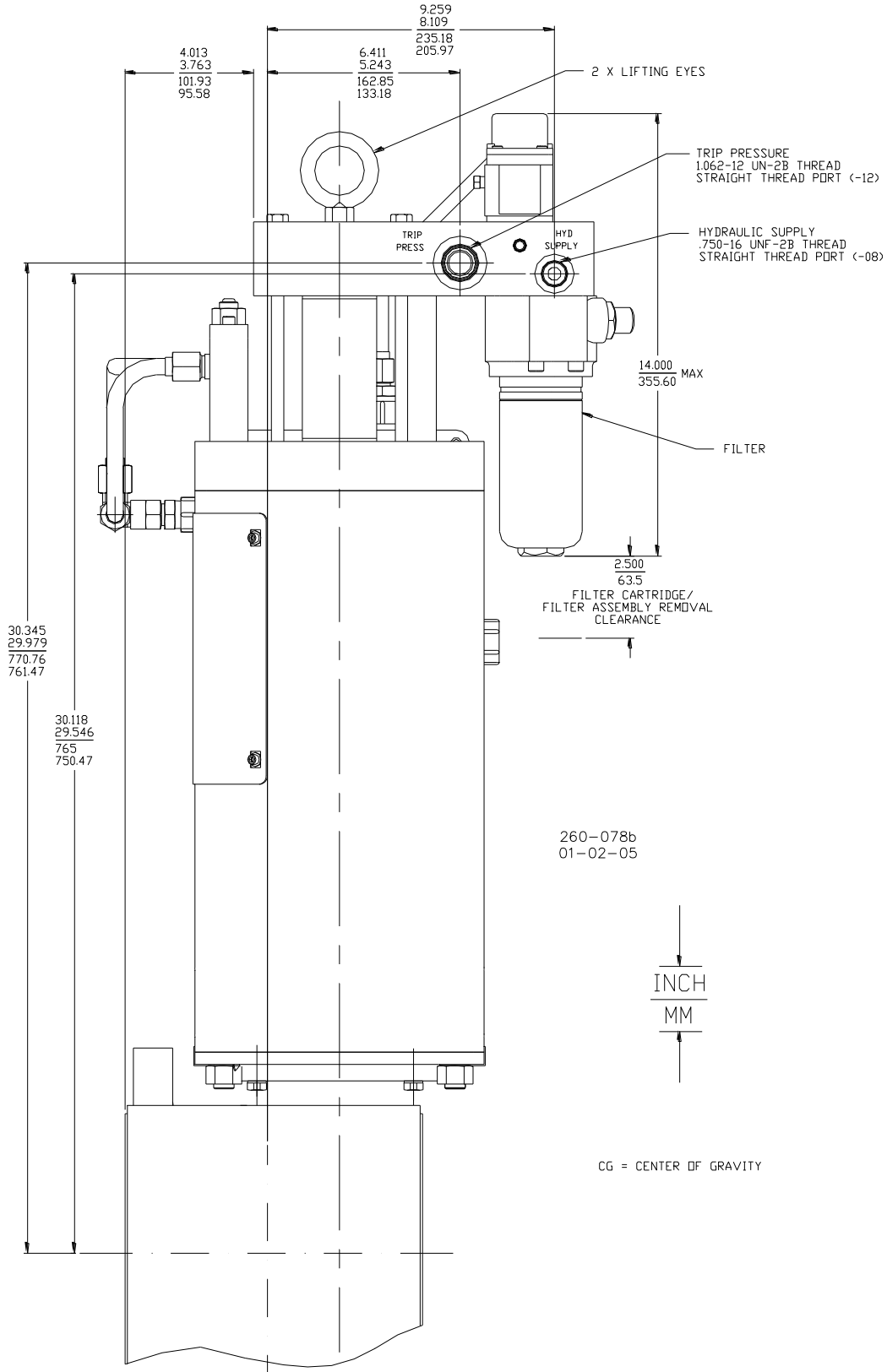

Figure 1-7b. Gas Stop/Ratio Valve Outline Drawing (6-inch, except SS-260)

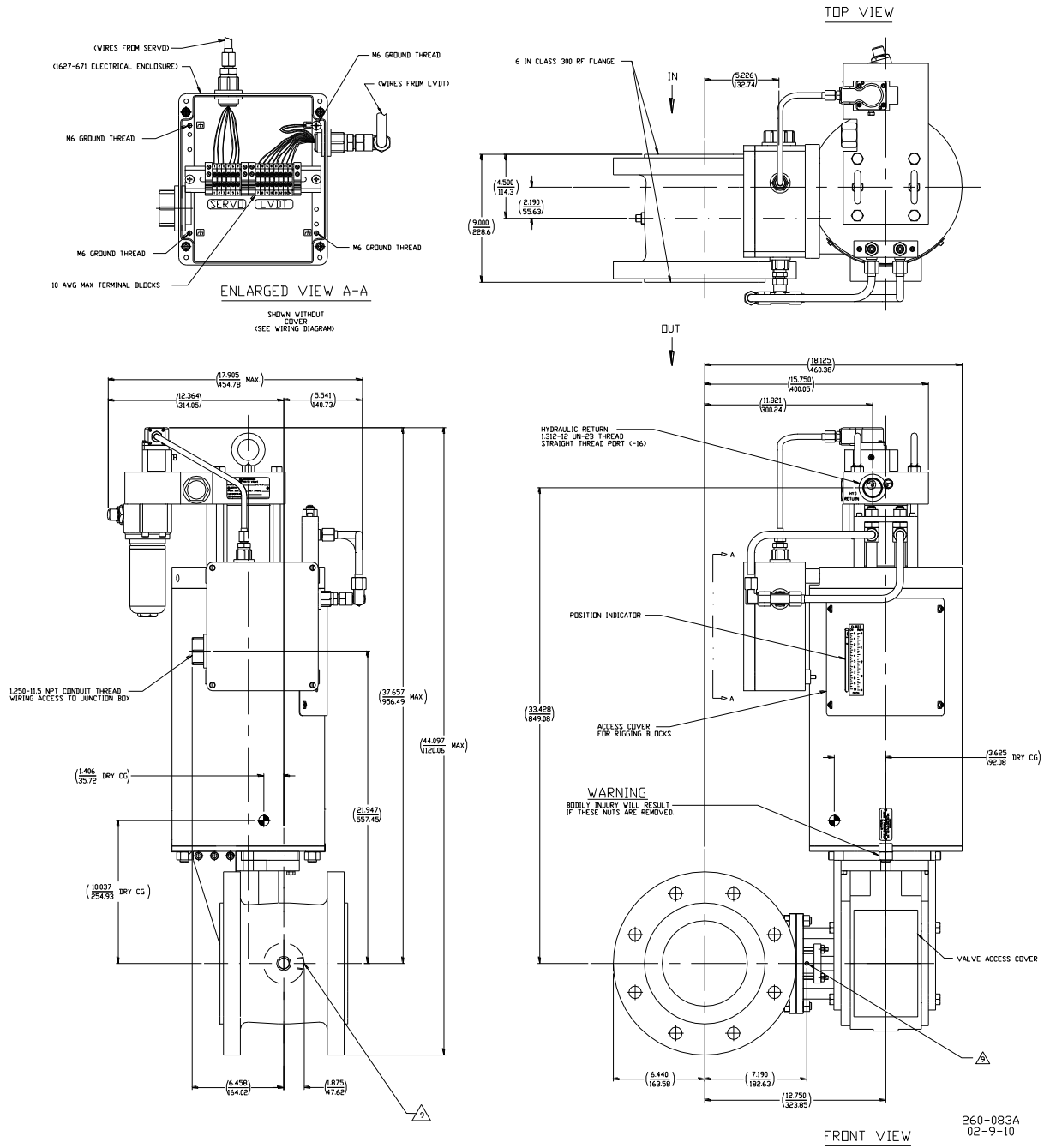

Figure 1-8a. Gas Stop/Ratio Valve Outline Drawing (6-inch, SS-260)

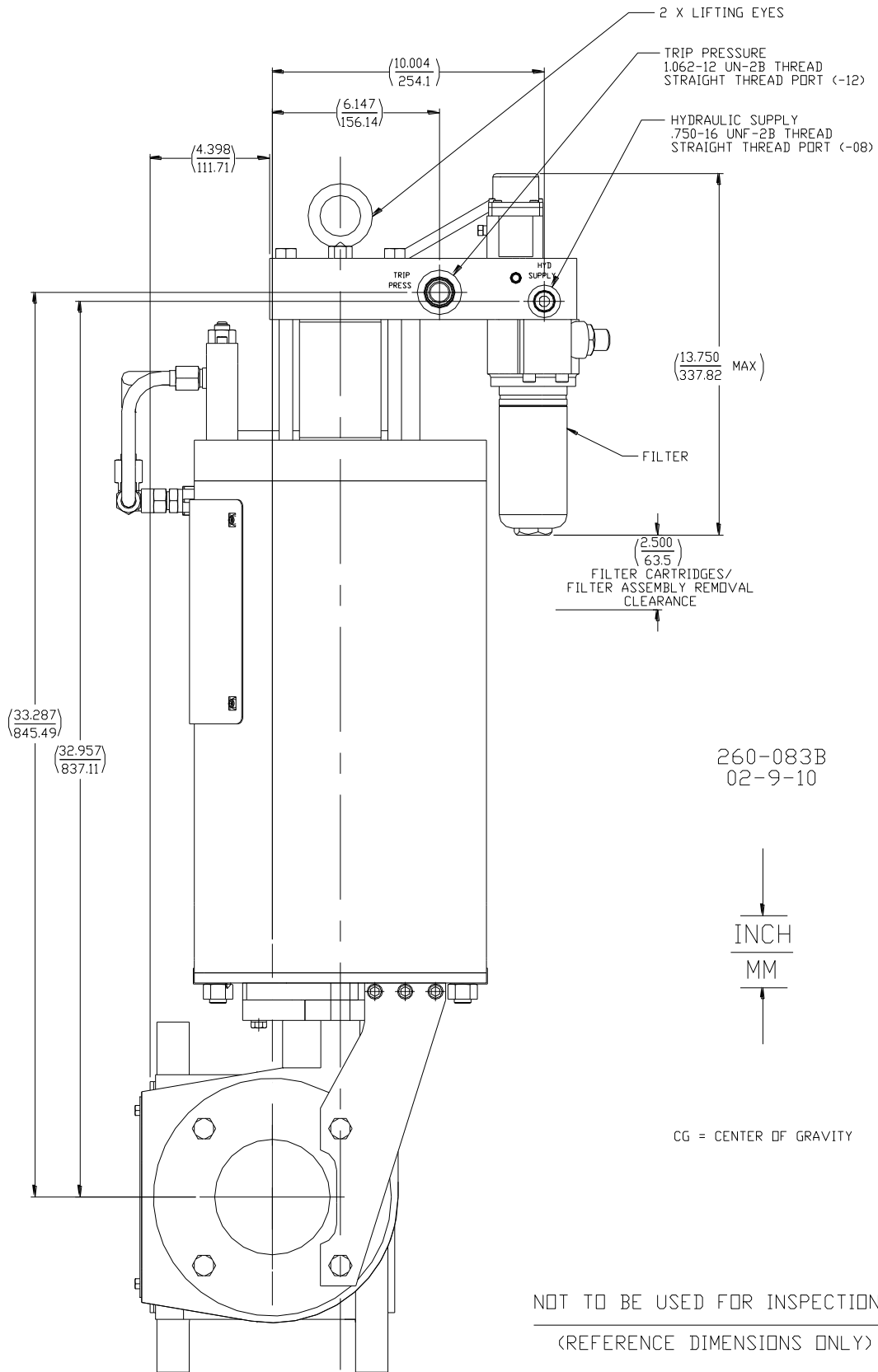

Figure 1-8b. Gas Stop/Ratio Valve Outline Drawing (6-inch, SS-260)

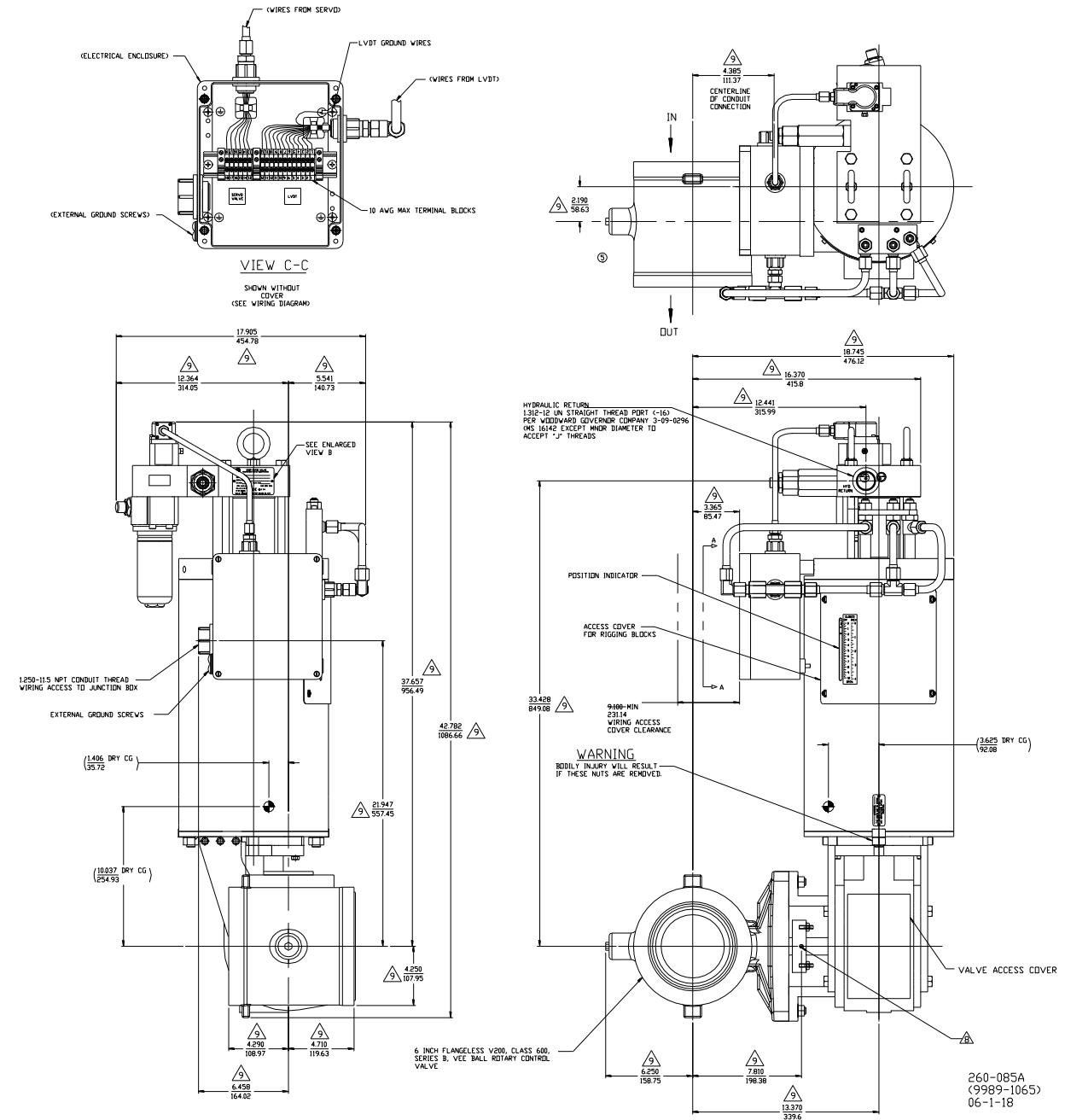

Figure 1-9a. Gas Stop/Ratio Valve Outline Drawing (6-inch, with 3 LVDTs, SS-260)



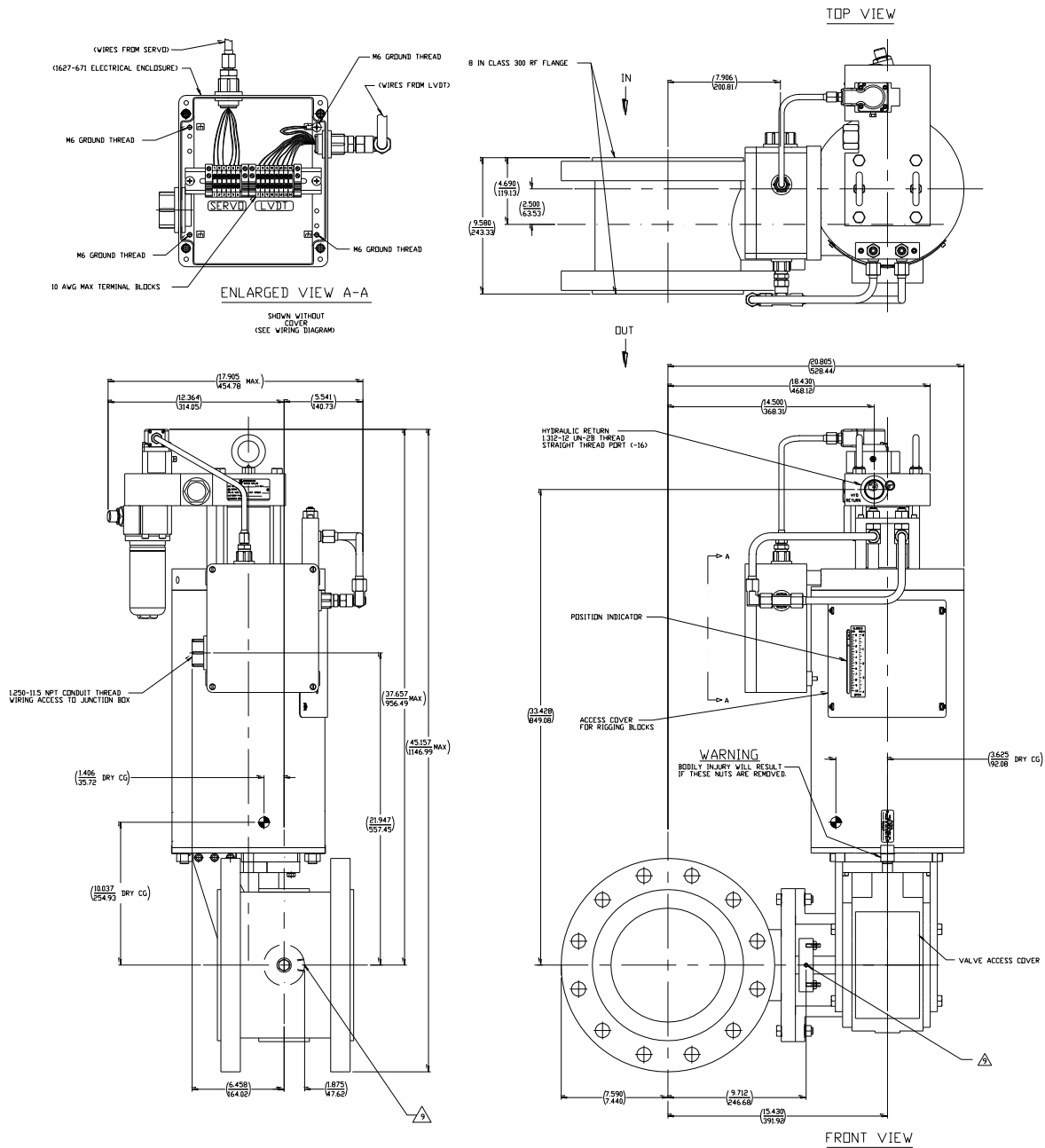

Figure 1-10a. Gas Stop/Ratio Valve Outline Drawing (8-inch, with 2 LVDTs)

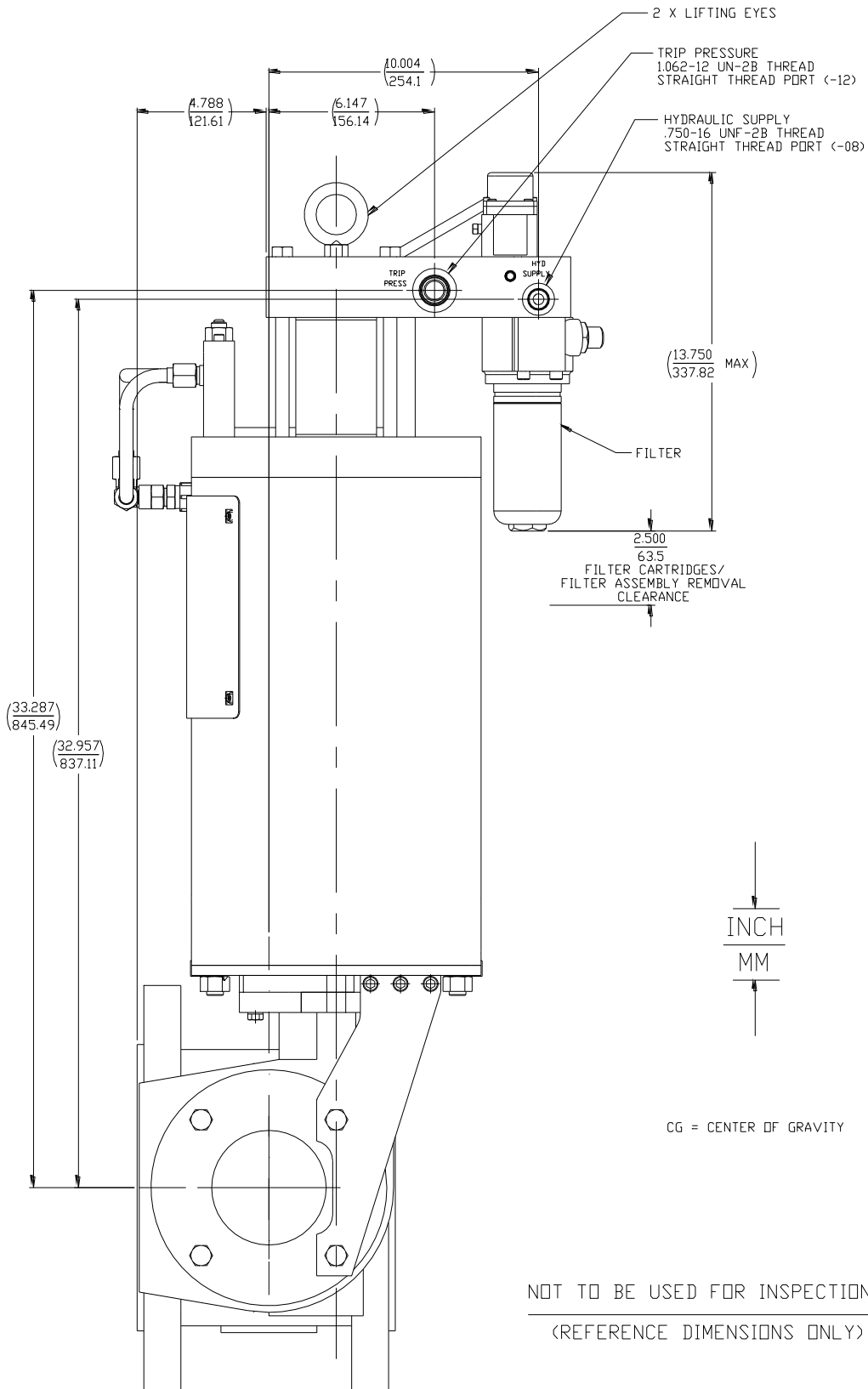

Figure 1-10b. Gas Stop/Ratio Valve Outline Drawing (8-inch, with 2 LVDTs)

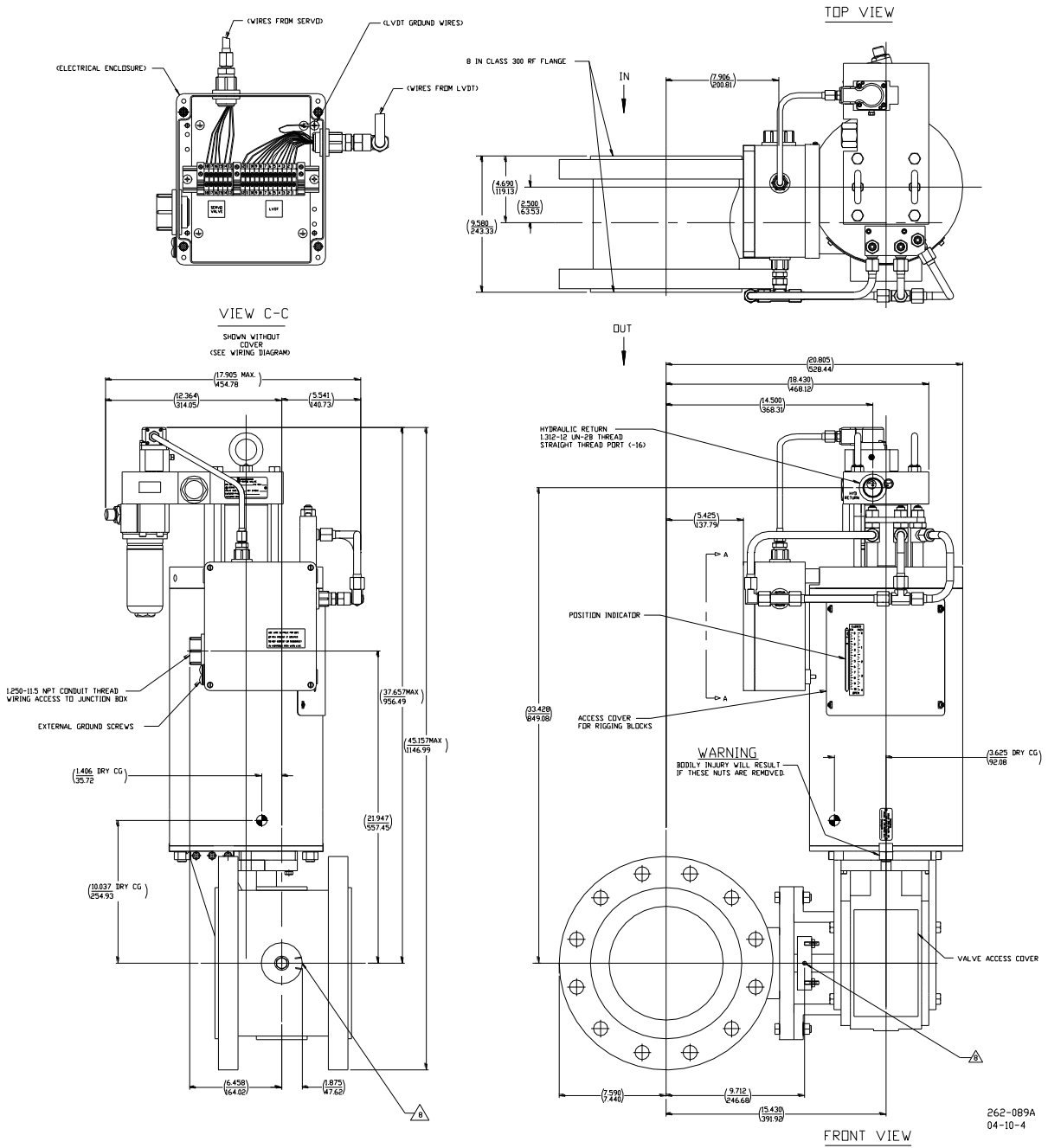

Figure 1-11a. Gas Stop/Ratio Valve Outline Drawing (8-inch, with 3 LVDTs)

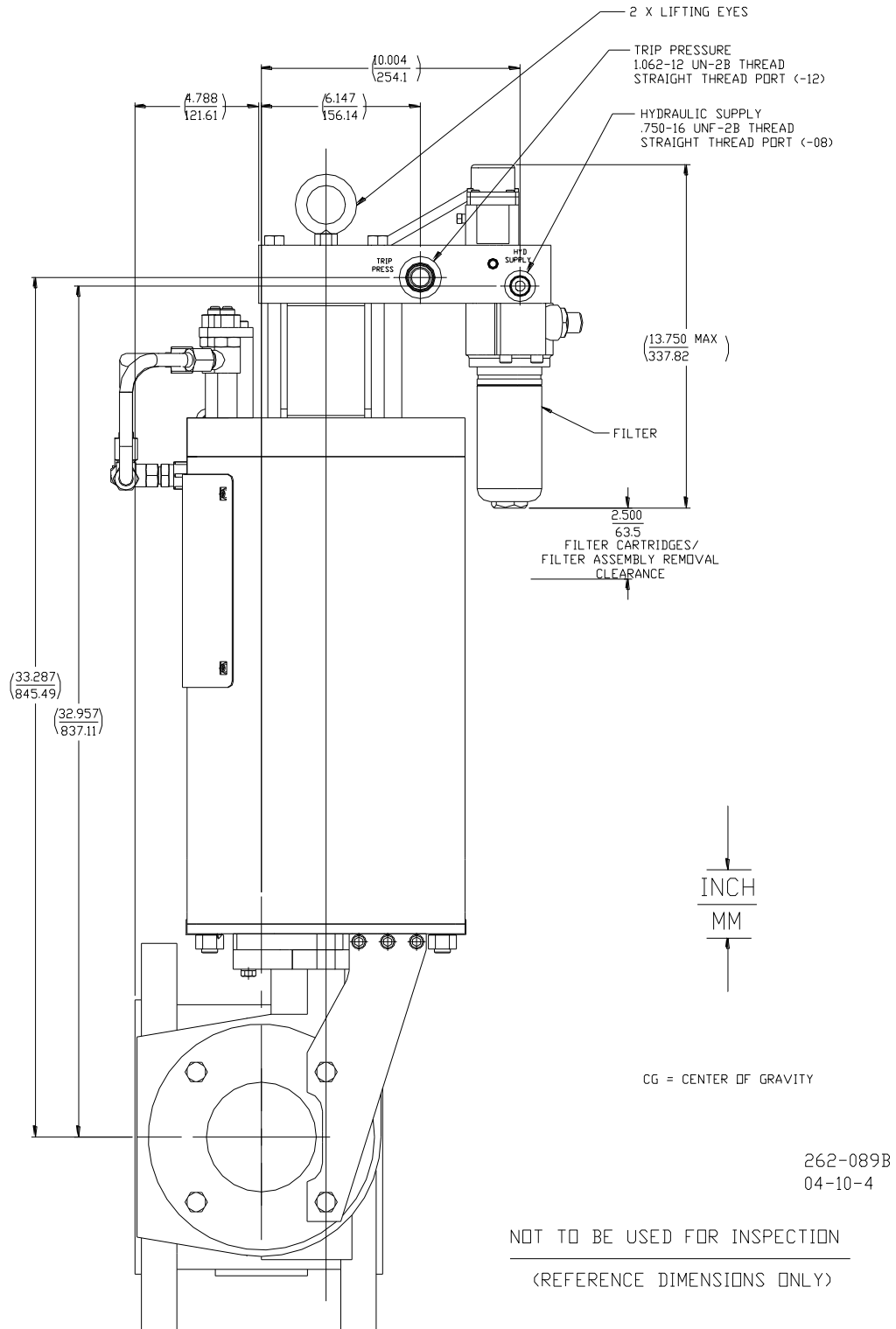

Figure 1-11b. Gas Stop/Ratio Valve Outline Drawing (8-inch, with 3 LVDTs)

## Chapter 2.

# Stop/Ratio Valve Operation

The Gas Stop/Ratio Valve actuator is controlled by an electronic servo-control system (not included), which compares the demanded and actual valve positions. The control system modulates the input current signal to the electrohydraulic servo valve to minimize the positioning system error. See Figure 1-2 for a functional schematic of the single acting actuator.

Hydraulic oil enters the actuator via a removable element filter with integral high  $\Delta P$  indicator and is directed to a four way, electrohydraulic servo valve used in a three-way configuration. The PC1 control pressure output from the servo valve is directed to the top of the hydraulic piston. When the force exerted by the hydraulic pressure exceeds the force of the opposing loading springs, the output piston extends, rotating the valve in the opening direction.

A trip relay valve assembly is interposed between the electrohydraulic servo control valve and the servo output stage. Loss or reduction of the externally supplied trip signal pressure causes the trip relay valve to shift position. This connects the upper cavity of the actuator piston to the hydraulic drain. The force supplied by the return springs pushes the actuation rod up, rotating the valve to the closed position.

Two redundant LVDT position feedback transducers are also mounted within each actuator. An optional third LVDT is available on the 6" and 8" stop/ratio actuators only. The LVDT sensor cores and support rods are connected to the main actuator output rod by a coupling arrangement guided on a bushing. This guide bushing maintains LVDT alignment to minimize core damage due to sliding wear and the associated loss of sensing accuracy.

## Chapter 3.

# Standard Component Details

### Triple Coil Electrohydraulic Servo Valve Assembly

The stop/ratio valve actuator utilizes a two stage hydraulic servo valve to modulate the position of the output shaft and thereby control the stop ratio valve. The first stage torque motor utilizes a triple wound coil, which controls the position of the first and second stage valves in proportion to the total electrical current applied to the three coils.

If the control system requires a rapid movement of the valve to increase fuel pressure to the control valves, the total current is increased well above the null current. In such a condition, supply oil is admitted to the cavity above the actuator piston. The flow rate delivered to the upper piston cavity is proportional to the total current applied to the three coils. Thus, the actuator stroke velocity and the valve opening are also proportional to the current (above null) supplied to the torque motor above the null point.

If the control system requires a rapid movement to reduce fuel pressure downstream of the stop/ratio valve, the total current is reduced well below the null current. In such a condition, the actuator piston cavity is connected to the hydraulic drain circuit. The flow rate returning from the upper piston cavity of the valve is proportional to the magnitude of the total current below the null value. The flow rate and closing velocity of the valve are in this case proportional to the total current below the null point.

Near the null current, the servo valve essentially isolates the upper piston cavity from the hydraulic supply and drain, and the upper piston pressure and spring load are balanced to maintain a constant position. The control system, which regulates the amount of current delivered to the coils, modulates the current supplied to the coil to obtain proper closed loop operation of the system.

### Trip Relay Valve Assembly

The stop/ratio valve utilizes a three-way, two position, hydraulically operated valve to switch the position of the gas stop/ratio valve. When the trip circuit pressure increases above  $24 \pm 6$  psid ( $165 \pm 41$  kPa) (applies to LPT), or increases above  $750 \pm 100$  psid ( $5171 \pm 690$  kPa) (applies to HPT) relative to hydraulic drain pressure, the three-way relay valve shifts position. The servo valve control port is then connected to the actuator upper piston cavity, and this interconnecting route is isolated from the drain passage. Actuation pressure is routed to the upper piston cavity of the valve, allowing the gas stop/ratio actuator to function.

As the trip circuit supply pressure reduces below  $22 \pm 6$  psid ( $152 \pm 41$  kPa) (applies to LPT), or reduces below  $750 \pm 100$  psid ( $5171 \pm 690$  kPa) (applies to HPT) relative to hydraulic drain pressure, the three-way relay valve shifts position such that the upper piston cavity is connected to the hydraulic drain circuit, and isolated from the hydraulic supply. As the pressure falls within the upper piston cavity, the return spring rapidly returns the actuator piston to the upward position, closing the stop ratio valve and shutting off fuel to the engine.

### Hydraulic Filter Assembly

The stop/ratio actuator is supplied with an integrated, high capacity filter. This broad range filter protects the internal hydraulic control components from large oil-borne contaminants that might cause the hydraulic components to stick or operate erratically. The filter is supplied with a visual indicator which indicates when the pressure differential exceeds the recommended value, indicating that replacement of the element is necessary.

## LVDT Position Feedback Sensors

The stop/ratio actuator uses dual LVDTs for position feedback. An optional third LVDT is available on the 6" and 8" stop/ratio actuators only. The LVDTs are factory set to give  $0.7 \pm 0.1$  Vrms feedback at minimum position and  $3.5 \pm 0.5$  Vrms feedback at maximum position. The actual voltage values for each LVDT are recorded on a label placed inside the actuator electrical box, for reference during field calibration.

## Chapter 4. Installation

### General

See the outline drawings (Figures 1-5 through 1-11) for:

- Overall dimensions
- Process piping flange locations
- Hydraulic fitting sizes
- Electrical connections
- Lift points and center of gravity
- Weight of the valve

The design of the Vee-Ball® valve requires that the rotary drive shaft be mounted horizontally. Additionally, a vertical actuator position is generally preferred to conserve floor space as well as ease of making electrical, fuel, and hydraulic connections and changing the hydraulic filter element.

The stop/ratio valve is designed for support by the piping flanges alone. Additional supports are neither needed nor recommended.

The standard stop/ratio valve is supplied with a left-hand orientation as shown in the outline drawing. The valve can be configured with a right-hand orientation; however, this request must be on the purchase order at the time the order is placed for this change to take place.

**WARNING**

External fire protection is not provided in the scope of this product. It is the responsibility of the user to satisfy any applicable requirements for their system.

**WARNING**

Due to typical noise levels in turbine environments, hearing protection should be worn when working on or around the valve.

**WARNING**

The surface of this product can become hot enough or cold enough to be a hazard. Use protective gear for product handling in these circumstances. Temperature ratings are included in the specification section of this manual.

**WARNING**

Do not lift or handle the valve by any conduit. Lift or handle the valve only by using the eyebolts.

**WARNING**

The surface temperature of this valve approaches the maximum temperature of the applied process media. It is the responsibility of the user to ensure that the external environment contains no hazardous gases capable of ignition in the range of the process media temperatures.

## Unpacking

The valve is shipped in an airtight bag with desiccant to ensure a non-corrosive environment. We recommend that the valve be kept in its shipping container until installation. If the valve is to be stored for extended periods of time, encase the valve in an airtight container with desiccant.

## Piping Installation

Refer to ANSI B16.5 for details of flange, gasket, and bolt types and dimensions.

Verify that the process piping flange-to-flange-face dimensions meet the requirements of the outline drawings (Figures 1-5 through 1-11) within standard piping tolerances. The valve should mount between the piping interfaces such that the flange bolts can be installed with only manual pressure applied to align the flanges. Mechanical devices such as hydraulic or mechanical jacks, pulleys, chain-falls, or similar should never be used to force the piping system to align with the valve flanges.

The stop/ratio valve is designed for support by the piping flanges alone; additional supports are neither needed nor recommended.

Grade 5 (metric class 8.8) bolts or studs should be used to install the valve into the process piping. The length and diameter for Class 300 flanges shall conform to the following table according to the valve flange size.

Table 4-1. Class 300 Flange Size and Fastener Specifications

Nominal Pipe Size	Number of Bolts	Diameter of Bolts	Stud Length	Machine Bolt Length
1 inch/ 25 mm	4	5/8 inch/ 16 mm	3.00 inch/ 76.2 mm	2.50 inch/ 63.5 mm
2 inch/ 51 mm	8	3/4 inch/ 19 mm	3.50 inch/ 88.9 mm	3.00 inch/ 76.2 mm
3 inch/ 76 mm	8	3/4 inch/ 19 mm	4.25 inch/ 108.0 mm	3.50 inch/ 88.9 mm
4 inch/ 102 mm	8	3/4 inch/ 19 mm	4.50 inch/ 114.3 mm	3.75 inch/ 95.2 mm
6 inch/ 152 mm	8	3/4 inch/ 19 mm	4.75 inch/ 120.6 mm	4.25 inch/ 108.0 mm
8 inch/ 203 mm	12	7/8 inch/ 22 mm	5.50 inch/ 139.7 mm	4.75 inch/ 120.6 mm

Flange gasket materials should conform to ANSI B16.20. The user should select a gasket material which will withstand the expected bolt loading without injurious crushing, and which is suitable for the service conditions.

When installing the valve into the process piping, it is important to properly torque the stud/bolts in the appropriate sequence in order to keep the flanges of the mating hardware parallel to each other. A two-step torque method is recommended. Once the studs/bolts are hand tightened, torque the studs/bolts in a crossing pattern to half the torque value listed in the following table. Once all studs/bolts have been torqued to half the appropriate value, repeat the pattern until the rated torque value is obtained.

Table 4-2. Bolt Torque Value

Bolt Size	Torque
5/8 inch/16 mm	150–155 lb-ft/203–210 N·m
3/4 inch/19 mm	250–260 lb-ft/339–353 N·m
7/8 inch/22 mm	375–390 lb-ft/508–529 N·m

## Hydraulic Connections

There are three hydraulic connections that must be made to each valve: supply, return, and trip oil. The connections to the valve are straight-thread O-ring style ports per SAE J514. The tubing up to the valve must be constructed to eliminate any transfer of vibration or other forces into the valve.

Make provisions for proper filtration of the hydraulic fluid that will supply the actuator. The system filtration should be designed to assure a supply of hydraulic oil with a maximum ISO 4406 contamination level of 18/16/13 and a preferred level of 16/14/11. The filter element included with the actuator is not intended to provide adequate filtration over the entire life of the actuator.

The hydraulic supply to the actuator is to be 0.500 inch (12.70 mm) tubing capable of supplying 10 US gallons/min (18 L/min) at 1200–1700 psig (8274–11 722 kPa).

The hydraulic drain should be 1.00 inch (25.4 mm) tubing and must not restrict the flow of fluid from the valve. The drain pressure must not exceed 30 psig (207 kPa) under any condition.

The trip relay valve supply should be 0.750 inch (19.05 mm) tubing. The Trip Relay Pressure should be above 40 psig (276 kPa) to enable the valve to function.

## Electrical Connections



**WARNING**

**EXPLOSION HAZARD—Do not connect or disconnect while circuit is live unless area is known to be non-hazardous.**



**WARNING**

**Due to the hazardous location listings associated with this valve, proper wire type and wiring practices are critical to operation.**



**WARNING**

**Protective earth (PE) ground must be connected on the junction box per the installation drawing to reduce the risk of electrostatic discharge in an explosive atmosphere.**

**NOTICE**

**Do not connect any cable grounds to “instrument ground”, “control ground”, or any non-earth ground system. Make all required electrical connections based on the wiring diagram (Figures 1-3 & 1-4).**

The use of cable with individually-shielded twisted pairs is recommended. All signal lines should be shielded to prevent picking up stray signals from nearby equipment. Installations with severe electromagnetic interference (EMI) may require shielded cable run in conduit, double-shielded wire, or other precautions. Connect the shields at the control system side or as indicated by the control system wiring practices, but never at both ends of the shield such that a ground loop is created. Wires exposed beyond the shield must be less than 2 inches (51 mm). The wiring should provide signal attenuation to greater than 60 dB.

### Servo Valve Electrical Connection

Servo valve cable must consist of three individually shielded twisted pairs. Each pair should be connected to one coil of the servo valve as indicated in Figures 1-3 and 1-4 (Wiring Diagram).



**WARNING**

**For valves with TIIS requirements (in Japan), the servo valve wiring must be installed with barriers, as shown in Figure 1-4b as required for use with the intrinsically safe method of protection.**

## LVDT Electrical Connection

The LVDT cable must consist of two individually shielded twisted pairs for each LVDT. A separate pair should be used for each of the excitation voltages to each LVDT, and a separate pair used for each of the feedback voltages from each LVDT.



**WARNING** For valves with TIS requirements (in Japan), the LVDT wiring must be installed with barriers, as shown in Figure 1-4a as required for use with the intrinsically safe method of protection.

## Fuel Vent Port

The fuel vent port must be vented to a safe location. In normal operation, this vent should have zero leakage. However, if excessive leakage is detected from this vent port, contact a Woodward representative for assistance.

## Electronic Settings

### Dynamic Tuning Parameters

It is imperative that the correct dynamic characteristics of this valve be input into the control system to ensure that the operation of the valve/control system is within acceptable limits.

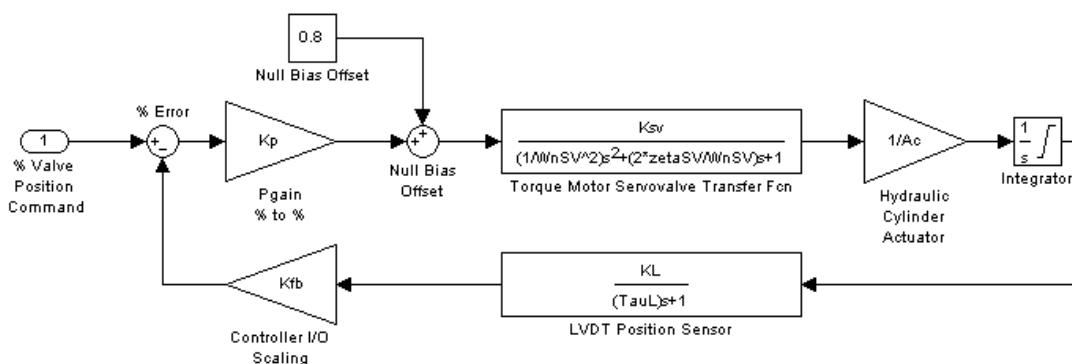

Figure 4-1. Stop/Ratio Valve Block Diagram

- Ksv nominal = 3.0 in<sup>3</sup>/sec/mA at 1600 psi supply (small actuator<sup>1</sup>);  
6.0 in<sup>2</sup>/sec/mA at 1600 psi supply (large actuator<sup>1</sup>);  
Ksv is proportional to square root of supply, and constant with position.
- ZetaSV = 0.7
- WnSV = 680 rad/sec (108 Hz); WnSV is proportional to square root of supply
- Ac = 2.4 in<sup>2</sup> (small actuator<sup>1</sup>); 4.9 in<sup>2</sup> (large actuator<sup>1</sup>)
- KL = 0.80 Vrms/inch
- Servo Travel = 3.5 inches
- TauL = 0.005 seconds (depends on excitation/demodulation)

<sup>1</sup>See page 2 for usage of small and large actuators

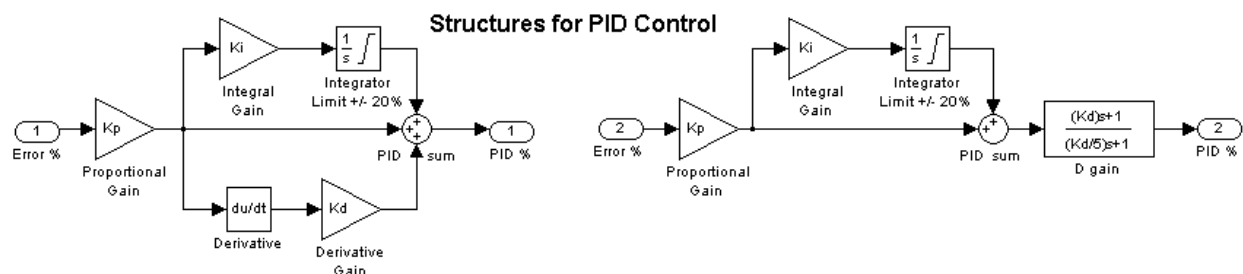

Figure 4-2. Structures for PID Control

Table 4-3. Recommended Control Gain Values for Different Control Types

Control Gain Settings	Proportional Control	Proportional Integral	Proportional Integral Derivative
	$K_p=5;$	$K_p=3; K_i=5;$	$K_p=3; K_i=5;$ $K_d=0.01$ or $\text{Tau Lead} = 0.01$

### Null Current Adjustment

Every valve shipped contains documentation that gives the actual Null Current as measured by Woodward. It is imperative that the control system null current match the as-measured current for each valve in the system. Incorrect null current setting, with proportional control only, will result in position error.

### Rigging Procedure

Inside the electrical enclosure of the valve, there is an adhesive label that contains the appropriate valve position (as a percent of full stroke), the physical stroke (inches), and the corresponding LVDT feedback signals for each LVDT (assuming 7.0 Vrms excitation at 3000 Hz).

Once the control system is connected to the valve and control of the valve is established, set the valve command position to 0% of full stroke. Measure the feedback voltage from each LVDT. Adjust the Offset in the feedback loop until the feedback voltage matches the documented values (see the label inside the electrical enclosure) for that position. Adjust the command position to 100% of full stroke. Adjust the Gain of the feedback loop until the LVDT feedback voltage matches the documented values. Set the command position to close the valve. Verify that the valve is closed visually and that the feedback voltage from the LVDT is  $0.7 \pm 0.1$  Vrms. This process may have to be repeated to ensure the feedback voltages at both the 0% and 100% command positions match the documented values.

# Chapter 5.

## Maintenance and Hardware Replacement

### Maintenance

**! WARNING**

Any cleaning by hand or with water spray must be performed while the area is known to be non-hazardous to prevent an electrostatic discharge in an explosive atmosphere.

The Gas Stop/Ratio Valve requires no maintenance or adjustment in preparation for or during normal operation.

Woodward recommends routine checks of the DP gauge on the filter assembly to verify that the filter is not partially clogged. If the DP indicator shows red, the filter element needs to be replaced.

In the event that any of the standard components of the valve become inoperative, field replacement of certain components is possible. Contact a Woodward representative for assistance.

### Hardware Replacement

**! WARNING**

**EXPLOSION HAZARD—Do not connect or disconnect while circuit is live unless area is known to be non-hazardous.**

Substitution of components may impair suitability for Class I, Division 2 or Zone 2.

**! WARNING**

To prevent possible serious personal injury, or damage to equipment, be sure all electric power, hydraulic pressure, and gas pressure have been removed from the valve and actuator before beginning any maintenance or repairs.

**! WARNING**

External fire protection is not provided in the scope of this product. It is the responsibility of the user to satisfy any applicable requirements for their system.

**! WARNING**

Due to typical noise levels in turbine environments, hearing protection should be worn when working on or around the Gas Stop/Ratio valve.

**! WARNING**

The surface of this product can become hot enough or cold enough to be a hazard. Use protective gear for product handling in these circumstances. Temperature ratings are included in the specification section of this manual.

**! WARNING**

Do not lift or handle the valve by any conduit. Lift or handle the valve only by using the eyebolts.

See the outline drawing (Figure 1-2) for the location of items.

## Hydraulic Filter Assembly/Cartridge

The hydraulic filter is located on the hydraulic manifold, hanging directly under the servo valve.

### Replacement of Filter Assembly

1. Remove four 0.312-18 UNC socket head cap screws.
2. Remove the filter assembly from manifold block.

#### **IMPORTANT**

The filter contains a large amount of hydraulic fluid that may be spilled during filter removal.

3. Remove the two O-rings present in the interface between the filter and the manifold.
4. Obtain a new filter assembly.
5. Place two new O-rings in the new filter assembly.
6. Install filter onto manifold assembly. Be sure to place the filter in the correct orientation. See the outline drawing (Figures 1-2).
7. Install four 0.312-18 cap screws through filter and torque into manifold to 106–146 lb-in (12.0–16.5 N·m).

### Replacement of Filter Cartridge

#### **IMPORTANT**

The filter contains a large amount of hydraulic fluid that may be spilled during filter removal.

1. Loosen and remove the bowl from the filter assembly by turning counterclockwise.
2. Remove the filter element by pulling it downward.
3. Obtain a new filter element.
4. Lubricate the O-ring on the ID of the cartridge with hydraulic fluid.
5. Install the cartridge into the assembly by sliding the open end of the cartridge upward onto the nipple.
6. Re-install the filter bowl onto the assembly by turning clockwise. For aluminum filter bowls with a face seal O-ring, see Figure 5-1. Tighten the bowl to 30-35 lb-ft. For steel filter bowls (Western or Donaldson) see Figure 5-2. Tighten the bowl by hand only.



Figure 5-1. Aluminum Filter Bowl



Figure 5-2. Steel Filter Bowl

### Trip Relay Valve Cartridge

The trip relay valve cartridge is located in the hydraulic manifold block.

#### **IMPORTANT**

Hydraulic fluid may spill during cartridge removal.

1. Using a 1.5 inch (~38+ mm) wrench, loosen the trip relay valve from the hydraulic manifold.
2. Slowly remove the cartridge from the manifold.
3. Obtain new trip relay valve cartridge and verify part number and revision with existing unit.
4. Verify that all O-rings and backup rings are present on new cartridge.
5. Lubricate O-rings with hydraulic fluid or petroleum jelly.
6. Install cartridge into manifold housing.
7. Torque to 80–90 lb-ft (108–122 N·m).

### Trip Relay Solenoid Valve

The trip relay solenoid valve is located on the side of the hydraulic manifold opposite the trip relay cartridge valve. See the outline drawing (Figures 1-2).

1. Remove the cover to the electrical junction box.
2. Disconnect the solenoid valve wires from the connector block labeled 11 and 12.
3. Loosen the conduit fittings from the electrical box, the solenoid valve, and the tee fitting in between.
4. Carefully remove the conduit from the solenoid valve and pull the wiring out of the conduit.
5. Using a 1-1/4 inch wrench (~32– mm), loosen the solenoid valve from the hydraulic manifold.
6. Slowly remove the solenoid valve from the manifold. **There could be some hydraulic fluid upon removal. Be cautious when handling.**
7. Obtain a new solenoid valve from Woodward.
8. Verify that both O-rings and back-up ring are present on the new valve.
9. Lubricate the O-rings with hydraulic fluid or petroleum jelly.
10. Install the new solenoid valve into the hydraulic manifold.
11. Torque the solenoid valve to 40–58 lb-ft (54–79 N·m).
12. Install wiring through the conduit and into the electrical box.
13. Connect the conduit to the solenoid valve and torque to 450–550 lb-in (51–62 N·m).
14. Torque the conduit to the electrical box and to the tee fitting to 450–550 lb-in (51–62 N·m).

15. Install wires into the solenoid valve connector blocks labeled 11 and 12. If it is necessary to cut the wires for installation, be sure to retain at least one service loop of wiring.
16. Replace the cover onto the junction box and tighten the screws.

Check for external leakage upon pressurizing the hydraulic system.

### Servo Valve

The servo valve is located on the hydraulic manifold directly above the filter assembly. Refer to the outline drawing (Figures 1-2).

## **IMPORTANT**

**There could be a substantial amount of hydraulic fluid upon removal.**

1. Remove the cover to the electrical junction box.
2. Disconnect the servo valve wires from the connector blocks labeled 1–6.
3. Loosen the conduit fittings from the electrical box and the servo valve.
4. Carefully remove the conduit from the servo valve and pull the wiring out of the conduit.
5. Remove the four #10-32 UNF socket head cap screws holding the servo valve to the manifold.
6. Discard the eight O-rings between the servo valve, the adapter plate, and the manifold.
7. Obtain replacement servo valve and verify part number and revision with existing unit.
8. Place four new O-rings on the adapter plate.
9. Reposition adapter plate onto hydraulic manifold ensuring hydraulic passages and bolt holes are aligned correctly. Be sure that all four O-rings remain in their proper location during assembly on the lower side of the adaptor plate facing the manifold.
10. Remove protective plate from replacement servo valve and verify that O-rings are on all four counter bores of the servo valve.
11. Place the servo valve onto the adapter plate that has been positioned on the hydraulic manifold. Be sure to orient the servo valve to match the original orientation. Be sure that all four O-rings remain in their proper location during assembly.
12. Install four #10-32 UNF socket head cap screws and torque to 55-57 lb-in (6.2-6.4 N·m).
13. Install the servo valve wiring through conduit and into electrical box.
14. Connect conduit to servo valve and torque to 450–550 lb-in (51–62 N·m).
15. Torque conduit to electrical box to 450–550 lb-in (51–62 N·m).
16. Install wires into servo valve connector blocks labeled 1–6 as shown in the wiring diagram (Figure 1-5). If it is necessary to cut wires for installation, be sure to retain at least one service loop of wiring.
17. Replace cover onto junction box and tighten screws.

## LVDT Replacement



### WARNING

To prevent possible personal injury, do NOT remove the spring cover (which is spring-loaded to over 1000 lbs/4448 N).

The LVDTs are located on the upper mounting plate located on the top of the large spring cylinder and below the hydraulic manifold. Refer to the outline drawing (Figures 1-2).

1. Remove the cover to the electrical junction box.
2. Disconnect both sets of LVDT wires from the connector blocks labeled 7–14.
3. Loosen the conduit fittings from the electrical box and from both LVDTs.
4. Carefully remove the conduit from the LVDTs and pull the wiring out of the conduit.
5. Disconnect the hydraulic drain connection for improved working space.

### IMPORTANT

There could be a substantial amount of hydraulic fluid upon removal.

6. Remove the 0.500-20 UNF mounting nut from the defective LVDT only.
7. Remove the two 0.250-20 UNC socket head cap screws holding the LVDT bracket to the upper mounting plate.
8. Carefully remove the LVDT assembly from the valve by lifting vertically upwards. Take care not to damage the good LVDT housing and rod.
9. Remove the four #10-32 UNF screws holding the access cover on the side of the spring cylinder to gain access to the LVDT rods.
10. Remove 0.375-24 UNF jam nut from defective LVDT rod.
11. Remove the defective LVDT rod using the 0.250 inch flats at the top of the threads. The rod will be difficult to unscrew due to the thread-locking feature incorporated into the spring plate.
12. Obtain replacement LVDT and verify part number and revision with existing unit.
13. Install replacement LVDT rod into spring plate, positioning the rod height to approximately match the other LVDT rod height.
14. Install the 0.375-24 UNF jam nut onto the LVDT rod but do not torque nut at this time.
15. Carefully slide replacement LVDT through upper mounting plate and over the LVDT rod. Be very careful not to force the LVDT at any time since this could damage the LVDT rod.
16. Carefully reinstall the good LVDT and bracket assembly through upper mounting plate and over the LVDT rod. Be very careful not to force the LVDT at any time since this could damage the LVDT rod.
17. Install the two 0.250-20 UNC socket head cap screws holding the LVDT bracket to the upper mounting plate and torque to 58–78 lb-in (6.6–8.8 N·m).
18. Install replacement LVDT into mounting bracket and torque 0.500-20 UNF mounting nut to 400–500 lb-in (45–56 N·m).
19. Mark one of the LVDT wire sets so that the two sets of LVDT wires are distinct. Once the LVDT wires are installed into the electrical box, it will be difficult to distinguish the two sets if they are not marked.
20. Install wiring through conduit and into electrical box.
21. Connect conduit to LVDTs and torque to 450–550 lb-in (51–62 N·m).
22. Torque conduit to electrical box to 450–550 lb-in (51–62 N·m).
23. Install wires into LVDT connector blocks labeled 7–14 as shown in the wiring diagram (Figure 1-5). If it is necessary to cut wires for installation, be sure to retain at least one service loop of wiring.
24. Reattach the hydraulic drain connection.
25. Once the LVDT is installed, it must then be calibrated as described below.

## LVDT Calibration

1. Whenever an LVDT is replaced, or whenever its core rod adjustment is disturbed, the LVDT output voltage must be calibrated in the following way.



**Use care and follow all instructions after removal of the spring access cover. Internal components can potentially crush fingers, and some components are held under significant force.**

2. Shut off the hydraulic supply to the stop/ratio actuator.
3. Remove the access cover from the side of the stop/ratio actuator housing by removing the four #10-32 UNF screws and washers, exposing the LVDT core rod adjustment.
4. Adjust the LVDT rod so that the output of the replaced LVDT is  $0.7 \pm 0.1$  Vrms with the stop/ratio actuator fully retracted (gas valve fully closed).
5. Tighten the 1.375-24 UNF LVDT rod jam nut to 270–320 lb-in (31–36 N·m).
6. Install the stroke measurement attachment bar (Woodward part number 1327-945 provided with the stop/ratio actuator) to the moving plate of the actuator as shown in Figure 5-1.
7. Attach an accurate stroke measurement device (dial indicator or equivalent), capable of measuring 4 inches (100 mm) of stroke, to the stop/ratio actuator body. Position the indicator plunger tip on the measurement bar, as shown in Figure 5-1.
8. Apply hydraulic pressure to the stop/ratio actuator and manually command the actuator to stroke  $3.500 \pm 0.005$  inches ( $88.90 \pm 0.13$  mm) by manipulating the electronic controller.
9. Note and record the LVDT output voltages at this 3.5 inch stroke position.
10. Remove the actuator control command, returning the actuator to its rest (gas valve closed) position.
11. Shut off the stop/ratio actuator hydraulic supply.
12. Update the stop/ratio control logic with the new LVDT output voltage value.
13. Remove the cover on the stop/ratio actuator electrical junction box.
14. Replace the original LVDT max output voltage value on the label in the stop/ratio actuator electrical junction box with the newly measured value.
15. Replace the cover on the junction box and tighten the screws.
16. Remove the dial indicator and measurement bar.



Figure 5-3. Stroke Measurement Attachment Bar

17. Reinstall the access cover with four #10-32 UNF screws, adjusting the closed indicator mark to align with the position indicator screw slot. Tighten the four cover attaching screws to 30–40 lb-in (3.4–4.5 N·m).

## Troubleshooting Charts

Faults in the fuel control or governing system are often associated with speed variations of the prime mover, but such speed variations do not always indicate fuel control or governing system faults. Therefore, when improper speed variations occur, check all components including the engine or turbine for proper operation. Refer to applicable electronic control manuals for assistance in isolating the trouble. The following steps describe troubleshooting for the gas fuel stop/ratio valve.

Disassembly of the gas fuel stop/ratio valve in the field is not recommended due to the dangerous forces contained in the springs. Under unusual circumstances where disassembly becomes necessary, all work and adjustments should be made by personnel thoroughly trained in the proper procedures.

When requesting information or service help from Woodward, it is important to include the part number and serial number of the valve assembly in your communication.

Symptom	Possible Causes	Remedies
External hydraulic leakage	Static O-ring seal(s) missing or deteriorated	Replace O-rings fitted to user-serviceable components (filter, servo valve, trip relay valve) as needed. Otherwise, return actuator to Woodward for service.
	Dynamic O-ring seal missing or deteriorated	Return actuator to Woodward for service.
Internal hydraulic leakage	Servo valve internal O-ring seal(s) missing or deteriorated	Replace servo valve.
	Servo valve metering edges worn	Replace servo valve.
	Piston seal missing or deteriorated	Return actuator to Woodward for service.
External gas fuel leakage	Piping flange gaskets missing or deteriorated	Replace gaskets.
	Piping flanges improperly aligned	Rework piping as needed to achieve alignment requirements detailed in Chapter 4.
	Piping flange bolts improperly torqued	Rework bolts as needed to achieve torque requirements detailed in Chapter 4.
	Packing follower needs adjustment	Adjust follower per Fisher manual Form 5290, Type Vee-Ball.
	Packing missing or deteriorated	Service packing per Fisher manual Form 5290, Type Vee-Ball.
Internal gas fuel leakage	Vee-Ball seal missing or deteriorated	Service seal per Fisher manual Form 5290, Type Vee-Ball, and Fisher Errata Sheet Type Vee-Ball SS-260.

Symptom	Possible Causes	Remedies
Valve will not open	Servo valve command current incorrect. (The sum of the current through the three coils of the servo valve must be greater than the null bias of the servo valve for the gas valve to open.)	Trace and verify that all wiring is in accordance with the electrical schematic (Figure 1-5) and the GE system wiring schematic(s). Pay special attention to the polarity of the wiring to the servo valve and LVDT.
	Servo valve failure	Replace servo valve.
	Hydraulic supply pressure inadequate	Supply pressure must be greater than 1200 psig/8274 kPa (1600 psig/11 032 kPa preferred).
	Trip solenoid valve failure Vee-Ball jammed	Replace solenoid valve. Service Vee-Ball per Fisher manual Form 5290, Type Vee-Ball.
Valve will not close	Servo valve command current incorrect. (The sum of the current through the three coils of the servo valve must be less than the null bias of the servo valve for the gas valve to close.)	Trace and verify that all wiring is in accordance with the electrical schematic (Figure 1-5) and the GE system wiring schematic(s). Pay special attention to the polarity of the wiring to the servo valve and LVDT.
	Servo valve failure	Replace servo valve.
	LVDT failure	Replace LVDT.
	Springs broken	Return actuator to Woodward for service.
	Linkage broken	Return actuator to Woodward for service.
	Vee-Ball jammed	Service Vee-Ball per Fisher manual Form 5290, Type Vee-Ball.
Valve will not respond smoothly	Hydraulic filter clogged	Check the differential pressure indicator on the filter housing.
	Servo valve spool sticking	Verify hydraulic contamination levels are within recommendations of Chapter 1. The use of dither may improve performance in contaminated systems.
	Servo valve internal pilot filter clogged	Replace servo valve.
	Excessive friction in Vee-Ball assembly	Service Vee-Ball per Fisher manual Form 5290, Type Vee-Ball, and Fisher Errata Sheet Type Vee-Ball SS-260.
	Rod-end(s) worn out	Return actuator to Woodward for service.
	Piston seal worn out	Return actuator to Woodward for service.
Actuator seals wear out prematurely	Hydraulic contamination level is excessive	Verify hydraulic contamination levels are within recommendations of Chapter 1. The use of excessive dither may reduce life in contaminated systems.
	System is oscillating (seal life is proportional to distance traveled). Even small oscillations (on the order of $\pm 1\%$ ) at slow frequencies (on the order of 0.1 Hz) cause wear to accumulate rapidly.	Determine and eliminate the root cause of oscillation.

## Chapter 6. Safety Management – Safe Position Fuel Shutoff Function

### Safety Function

The Gas Stop/Ratio Valve will move to the closed position within the full stroke trip time listed in this manual.

### Product Variations Certified

The SIL (Safety Integrity Level) rated Gas Stop/Ratio Valves for fuel shutoff are designed and certified to the functional safety standards according to IEC 61508, Parts 1 through 7. Reference the exida FMEDA report: WOO 19/05-012 R002, and Certification: WOO 1905012 C001. The exida FMEDA report is available on a per request basis from Woodward.

The functional safety requirements in this chapter apply to all Gas Stop/Ratio Valve configurations listed in Table 6-1.

The Gas Stop/Ratio Valve configurations listed in Table 5-1 are certified for use in applications up to SIL 3 according to IEC 61508. The SIL of an entire SIF (Safety Instrumented Function) must be verified via calculation of Average PFD (Probability of Failure on Demand) considering redundant architectures, proof test interval, proof test effectiveness, any automatic diagnostics, average repair and the specific failure rates of all products included in the SIF. Each element must be checked to assure compliance with the minimum HFT (Hardware Fault Tolerance) requirements.

The SonicFlo™ Gas Fuel Control Valves are classified as a device that is part Type A element according to IEC 61508, having a HFT of 0.

The Gas Stop/Ratio Valves are designed and verified to withstand the worst-case (or greater) expected environmental conditions as listed in other sections of this manual.

### SFF (Safe Failure Fraction) for Gas Stop/Ratio Valve – Over Speed SIF

The Gas Stop/Ratio Valve is only one part of a shutoff system that supports an over-speed shutdown SIF. This system consists of a speed sensor, a processing unit and a fuel shutoff actuation subsystem of which Gas Stop/Ratio Valve is a component.

The SFF (Safe Failure Fraction) for each subsystem should be calculated. The SFF summarizes the fraction of failures which lead to a safe state plus the fraction of failures which will be detected by diagnostic measures and lead to a defined safety action. This is reflected in the following formulas for SFF:

$$\text{SFF} = \lambda_{SD} + \lambda_{SU} + \lambda_{DD} / \lambda_{TOTAL}$$

Where  $\lambda_{TOTAL} = \lambda_{SD} + \lambda_{SU} + \lambda_{DD} + \lambda_{DU}$

The failure rates listed below, for only the Gas Stop/Ratio Valve, do not include failures due to wear-out of any components and are only valid for the useful lifetime of the Gas Stop/Ratio Valve. They reflect random failures and include failures due to external events such as unexpected use. Reference the exida FMEDA report: WOO 19/05-012 R002 for detailed information concerning the SFF and PFD.

Failure Rates for Static Applications[1] with Good Maintenance Assumptions in FIT @ SSI=2

Table 6-1. Failure Rates according to IEC 61508 in FIT

Application/Device/Configuration	$\lambda$ SD	$\lambda$ SU [2]	$\lambda$ DD	$\lambda$ DU	#	E
Full Stroke, Clean Service, Hydraulic Trip	0	197	0	803	2088	575
Full Stroke, Clean Service, Electric Trip	0	575	0	923	2301	585
Full Stroke, Clean Service, Hydraulic Trip, with PVST	69	128	429	374	2088	575
Full Stroke, Clean Service, Electric Trip, with PVST	443	132	526	397	2301	585

According to IEC 61508 the architectural constraints of an element must be determined. This can be done by following the 1H approach according to 7.4.4.2 of IEC 61508 or the 2H approach according to 7.4.4.3 of IEC 61508. Reference the exida FMEDA report: WOO 19/05-012 R002 for additional information, including the assumptions used for the calculated FIT (Failure in Time) values in Table 5-1.

To claim diagnostic coverage for Partial Valve Stroke Testing (PVST), the PVST must be automatically performed at a rate at least ten times faster than the demand frequency with inclusions of position detection from the actuator's LVDT(s). Additionally, the PVST of the safety instrumented function must provide a full cycle test of the solenoid and/or hydraulic pilot valve depending on the device configuration. In cases where this is not true, another method must be used to perform a full solenoid/pilot valve cycle during automated diagnostics in order to use the PVST numbers.

## Response Time Data

The Gas Stop/Ratio Valve full stroke trip time is as listed in this manual.

## Limitations

When proper installation, maintenance, proof testing, and environmental limitations are observed, the design life of the Gas Stop/Ratio Valve is 250,000 hours of operation. Under "normal" operating conditions Gas Stop/Ratio Valves should be serviced with a factory or authorized service center overhaul every 50,000 hours not to exceed 6 years in service. Refer to service bulletin 01614 for additional service guidelines.

## Management of Functional Safety

The Gas Stop/Ratio Valve is intended for use according to the requirements of a safety lifecycle management process such as IEC 61508 or IEC 61511. The safety performance numbers in this chapter can be used for the evaluation of the overall safety lifecycle.

[1] Static Application failure rates are applicable if the device is static for a period of more than 200 hours.

[2] It is important to realize that the No Effect failures are no longer included in the Safe Undetected failure category according to IEC 61508, ed2, 2010.

## Restrictions

The user must complete a full functional check of the Gas Stop/Ratio Valve after initial installation, and after any modification of the overall safety system. No modification shall be made to the Gas Stop/Ratio Valve unless directed by Woodward. This functional check should include as much of the safety system as possible, such as sensors, transmitters, actuators, and trip blocks. The results of any functional check shall be recorded for future review.

## Competence of Personnel

All personnel involved in the installation and maintenance of the Gas Stop/Ratio Valve must have appropriate training. Training and guidance materials are included in this manual. These personnel shall report back to Woodward any failures detected during operation that may impact functional safety.

## Operation and Maintenance Practice

A periodic proof (functional) test of the Gas Stop/Ratio Valve is required to verify that any dangerous faults not detected by safety controller internal run-time diagnostics are detected. More information is in the "Proof Test" section below. The frequency of the proof test is determined by the overall safety system design, of which the Gas Stop/Ratio Valve is part of the safety system. The safety numbers are given in the following sections to help the system integrator determine the appropriate test interval.

No special tools are required for operation or maintenance of the SonicFlo™ Gas Fuel Control Valve.

### Installation and Site Acceptance Testing

Installation and use of the Gas Stop/Ratio Valve must conform to the guidelines and restrictions included in this manual.

### Functional Testing after Initial Installation

A functional test of Gas Stop/Ratio Valve is required prior to use in a safety system. This should be done as part of the overall safety system installation check and should include all I/O interfaces to and from the Gas Stop/Ratio Valve. For guidance on the functional test, see the Proof Test procedure below.

### Functional Testing after Changes

A functional test of the Gas Stop/Ratio Valve is required after making any changes that affect the safety system. Although there are functions in the Gas Stop/Ratio Valve that are not directly safety related, it is recommended that a functional test be performed after any change.

### Proof Test (Functional Test)

The SonicFlo™ Gas Fuel Control Valve must be periodically proof tested to ensure there are no dangerous faults present that are not detected by on-line diagnostics. This proof test should be performed at least once per year.

### Suggested Proof Test

The suggested proof test consists of a full stroke of the valve, shown in the table below.

Table 6-2. Suggested Proof Test

Step	Action
1	Bypass the safety function and take appropriate action to avoid a false trip.
2	Issue a trip command to the Gas Stop/Ratio Valve to force the actuator/valve assembly to the Fail-Safe state and confirm that the Safe State was achieved and within the correct time.
Note: This tests for all failures that could prevent the functioning of the control valve as well as the rest of the final control element.	
3	Inspect the actuator and valve for any leaks, visible damage or contamination.
4	Re-store the original supply/input to the actuator and confirm that the normal operating state was achieved.
5	Remove the bypass and otherwise restore normal operation.

For the test to be effective the movement of the valve must be confirmed. To confirm the effectiveness of the test both the travel of the valve and slew rate must be monitored and compared to expected results to validate the testing.

## Proof Test Coverage

The Proof Test Coverage for the Gas Stop/Ratio Valve is given in the table below.

Table 6-3. Proof Test Coverage

Device	ADUPT5F (FIT)	Proof Test Coverage	
		No PVST	with PVST
Full Stroke, Clean Service, Hydraulic Trip	247	69%	34%
Full Stroke, Clean Service, Electric Trip	252	73%	37%

The suggested proof test and proof test coverage is referenced in exida FMEDA report; WOO 19/05-012 R002.

## Terms and Definitions

<b>Safety Freedom</b>	Freedom from unacceptable risk of harm
<b>Basic Safety</b>	The equipment must be designed and manufactured such that it protects against risk of damage to persons by electrical shock and other hazards and against resulting fire and explosion. The protection must be effective under all conditions of the nominal operation and under single fault condition
<b>Functional Safety</b>	The ability of a system to carry out the actions necessary to achieve or to maintain a defined safe state for the equipment / machinery / plant / apparatus under control of the system
<b>Safety Assessment</b>	The investigation to arrive at a judgment - based on evidence - of the safety achieved by safety-related systems
<b>Element</b>	Part of a subsystem comprising a single component or any group of components that performs one or more element safety functions
<b>Fail-Safe State</b>	State of the process when safety is achieved; A loss or significant decrease of inlet supply pressure establish high volume reverse flow exhaust
<b>Fail Safe</b>	Failure that causes the hydraulic interface valve to go to the defined fail-safe state without a demand from the process
<b>Fail Dangerous</b>	Failure that does not permit the SIF to respond to a demand from the process (i.e. being unable to go to the defined fail-safe state)
<b>Fail Dangerous Undetected</b>	Failure that is dangerous and that is not being diagnosed by automatic testing
<b>Fail Dangerous Detected</b>	Failure that is dangerous but is detected by automatic testing
<b>Fail Annunciation Undetected</b>	Failure that does not cause a false trip or prevent the safety function but does cause loss of an automatic diagnostic and is not detected by another diagnostic
<b>Fail Annunciation Detected</b>	Failure that does not cause a false trip or prevent the safety function but does cause loss of an automatic diagnostic or false diagnostic indication
<b>Fail No Effect</b>	Failure of a component that is part of the safety function but that has no effect on the safety function
<b>Low Demand Mode</b>	Mode where the safety function is only performed on demand, to transfer the EUC into a specified safe state, and where the frequency of demands is no greater than one per year and no greater than twice the proof test frequency
<b>High Demand Mode</b>	Mode where the safety function is only performed on demand, to transfer the EUC into a specified safe state, and where the frequency of demands is greater than one per year or greater than twice the proof test frequency
<b>Continuous Mode</b>	Mode where the safety function maintains the EUC in a safe state as part of normal operation

## Acronyms

<b>EUC</b>	Equipment Under Control
<b>FMEDA</b>	Failure Modes, Effects and Diagnostic Analysis
<b>HFT</b>	Hardware Fault Tolerance
<b>MOC</b>	Management of Change. These are specific procedures to follow for any work activities in compliance with government regulatory authorities or requirements of a standard
<b>PFDavg</b>	Average Probability of Failure on Demand
<b>PFH</b>	Probability of Failure per Hour
<b>SFF</b>	Safe Failure Fraction, the fraction of the overall failure rate of an element that results in either a safe fault or a diagnosed dangerous fault
<b>SIF</b>	Safety Instrumented Function, a set of equipment intended to reduce the risk due to a specific hazard (a safety loop)
<b>SIL</b>	Safety Integrity Level, discrete level (one out of a possible four) for specifying the safety integrity requirements of the safety functions to be allocated to the E/E/PE safety-related systems where Safety Integrity Level 4 is the highest level and Safety Integrity Level 1 is the lowest
<b>SIS</b>	Safety Instrumented System – Implementation of one or more Safety Instrumented Functions. A SIS is composed of any combination of sensor(s), logic solver(s), and final element(s)

## Chapter 7.

# Product Support and Service Options

### Product Support Options

If you are experiencing problems with the installation, or unsatisfactory performance of a Woodward product, the following options are available:

- Consult the troubleshooting guide in the manual.
- Contact the manufacturer or packager of your system.
- Contact the Woodward Full Service Distributor serving your area.
- Contact Woodward technical assistance (see “How to Contact Woodward” later in this chapter) and discuss your problem. In many cases, your problem can be resolved over the phone. If not, you can select which course of action to pursue based on the available services listed in this chapter.

**OEM or Packager Support:** Many Woodward controls and control devices are installed into the equipment system and programmed by an Original Equipment Manufacturer (OEM) or Equipment Packager at their factory. In some cases, the programming is password-protected by the OEM or packager, and they are the best source for product service and support. Warranty service for Woodward products shipped with an equipment system should also be handled through the OEM or Packager. Please review your equipment system documentation for details.

**Woodward Business Partner Support:** Woodward works with and supports a global network of independent business partners whose mission is to serve the users of Woodward controls, as described here:

- A **Full Service Distributor** has the primary responsibility for sales, service, system integration solutions, technical desk support, and aftermarket marketing of standard Woodward products within a specific geographic area and market segment.
- An **Authorized Independent Service Facility (AISF)** provides authorized service that includes repairs, repair parts, and warranty service on Woodward's behalf. Service (not new unit sales) is an AISF's primary mission.

A current list of Woodward Business Partners is available at:

<https://www.woodward.com/en/support/industrial/service-and-spare-parts/find-a-local-partner>

### Product Service Options

The following factory options for servicing Woodward products are available through your local Full-Service Distributor or the OEM or Packager of the equipment system, based on the standard Woodward Product and Service Warranty (Woodward North American Terms and Conditions of Sale 5-09-0690) that is in effect at the time the product is originally shipped from Woodward or a service is performed:

- Replacement/Exchange (24-hour service)
- Flat Rate Repair
- Flat Rate Remanufacture

**Replacement/Exchange:** Replacement/Exchange is a premium program designed for the user who is in need of immediate service. It allows you to request and receive a like-new replacement unit in minimum time (usually within 24 hours of the request), providing a suitable unit is available at the time of the request, thereby minimizing costly downtime. This is a flat-rate program and includes the full standard Woodward product warranty (Woodward North American Terms and Conditions of Sale 5-09-0690).

This option allows you to call your Full-Service Distributor in the event of an unexpected outage, or in advance of a scheduled outage, to request a replacement control unit. If the unit is available at the time of the call, it can usually be shipped out within 24 hours. You replace your field control unit with the like-new replacement and return the field unit to the Full-Service Distributor.

Charges for the Replacement/Exchange service are based on a flat rate plus shipping expenses. You are invoiced the flat rate replacement/exchange charge plus a core charge at the time the replacement unit is shipped. If the core (field unit) is returned within 60 days, a credit for the core charge will be issued.

**Flat Rate Repair:** Flat Rate Repair is available for the majority of standard products in the field. This program offers you repair service for your products with the advantage of knowing in advance what the cost will be. All repair work carries the standard Woodward service warranty (Woodward North American Terms and Conditions of Sale 5-09-0690) on replaced parts and labor.

**Flat Rate Remanufacture:** Flat Rate Remanufacture is very similar to the Flat Rate Repair option with the exception that the unit will be returned to you in "like-new" condition and carry with it the full standard Woodward product warranty (Woodward North American Terms and Conditions of Sale 5-09-0690). This option is applicable to mechanical products only.

## Returning Equipment for Repair

If a control (or any part of an electronic control) is to be returned for repair, please contact your Full-Service Distributor in advance to obtain Return Authorization and shipping instructions.

When shipping the item(s), attach a tag with the following information:

- Return authorization number
- Name and location where the control is installed
- Name and phone number of contact person
- Complete Woodward part number(s) and serial number(s)
- Description of the problem
- Instructions describing the desired type of repair

### Packing a Control

Use the following materials when returning a complete control:

- Protective caps on any connectors
- Antistatic protective bags on all electronic modules
- Packing materials that will not damage the surface of the unit
- At least 100 mm (4 inches) of tightly packed, industry-approved packing material
- A packing carton with double walls
- A strong tape around the outside of the carton for increased strength

### **NOTICE**

To prevent damage to electronic components caused by improper handling, read and observe the precautions in Woodward manual 82715, *Guide for Handling and Protection of Electronic Controls, Printed Circuit Boards, and Modules*.

## Replacement Parts

When ordering replacement parts for controls, include the following information:

- The part number(s) (XXXX-XXXX) that is on the enclosure nameplate
- The unit serial number, which is also on the nameplate

## Engineering Services

Woodward offers various Engineering Services for our products. For these services, you can contact us by telephone, by email, or through the Woodward website.

- Technical Support
- Product Training
- Field Service

**Technical Support** is available from your equipment system supplier, your local Full-Service Distributor, or from many of Woodward's worldwide locations, depending upon the product and application. This service can assist you with technical questions or problem solving during the normal business hours of the Woodward location you contact. Emergency assistance is also available during non-business hours by phoning Woodward and stating the urgency of your problem.

**Product Training** is available as standard classes at many of our worldwide locations. We also offer customized classes, which can be tailored to your needs and can be held at one of our locations or at your site. This training, conducted by experienced personnel, will assure that you will be able to maintain system reliability and availability.

**Field Service** engineering on-site support is available, depending on the product and location, from many of our worldwide locations or from one of our Full-Service Distributors. The field engineers are experienced both on Woodward products as well as on much of the non-Woodward equipment with which our products interface.

For information on these services, please contact one of the Full-Service Distributors listed at:

<https://www.woodward.com/en/support/industrial/service-and-spare-parts/find-a-local-partner>

## Contacting Woodward's Support Organization

For the name of your nearest Woodward Full-Service Distributor or service facility, please consult our worldwide directory at <https://www.woodward.com/support>, which also contains the most current product support and contact information.

You can also contact the Woodward Customer Service Department at one of the following Woodward facilities to obtain the address and phone number of the nearest facility at which you can obtain information and service.

<b>Products Used in Electrical Power Systems</b>	
<u>Facility</u>	<u>Phone Number</u>
Brazil	+55 (19) 3708 4800
China	+86 (512) 8818 5515
Germany	+49 (711) 78954-510
India	+91 (124) 4399500
Japan	+81 (43) 213-2191
Korea	+82 (51) 636-7080
Poland	+48 (12) 295 13 00
United States	+1 (970) 482-5811

<b>Products Used in Engine Systems</b>	
<u>Facility</u>	<u>Phone Number</u>
Brazil	+55 (19) 3708 4800
China	+86 (512) 8818 5515
Germany	+49 (711) 78954-510
India	+91 (124) 4399500
Japan	+81 (43) 213-2191
Korea	+82 (51) 636-7080
United States	+1 (970) 482-5811

<b>Products Used in Industrial Turbomachinery Systems</b>	
<u>Facility</u>	<u>Phone Number</u>
Brazil	+55 (19) 3708 4800
China	+86 (512) 8818 5515
India	+91 (124) 4399500
Japan	+81 (43) 213-2191
Korea	+ 82 (51) 636-7080
Poland	+48 (12) 295 13 00
United States	+1 (970) 482-5811

## Technical Assistance

If you need to contact technical assistance, you will need to provide the following information. Please write it down here before contacting the Engine OEM, the Packager, a Woodward Business Partner, or the Woodward factory:

### General

Your Name \_\_\_\_\_

Site Location \_\_\_\_\_

Phone Number \_\_\_\_\_

Fax Number \_\_\_\_\_

---

### Prime Mover Information

Manufacturer \_\_\_\_\_

Turbine Model Number \_\_\_\_\_

Type of Fuel (gas, steam, etc.) \_\_\_\_\_

Power Output Rating \_\_\_\_\_

Application (power generation, marine,  
etc.) \_\_\_\_\_

---

### Control/Governor Information

#### Control/Governor #1

Woodward Part Number & Rev. Letter \_\_\_\_\_

Control Description or Governor Type \_\_\_\_\_

Serial Number \_\_\_\_\_

---

#### Control/Governor #2

Woodward Part Number & Rev. Letter \_\_\_\_\_

Control Description or Governor Type \_\_\_\_\_

Serial Number \_\_\_\_\_

---

#### Control/Governor #3

Woodward Part Number & Rev. Letter \_\_\_\_\_

Control Description or Governor Type \_\_\_\_\_

Serial Number \_\_\_\_\_

---

### Symptoms

Description \_\_\_\_\_

\_\_\_\_\_

*If you have an electronic or programmable control, please have the adjustment setting positions or the menu settings written down and with you at the time of the call.*

## Revision History

### Changes in Revision K—

- Updated IECEx in Regulatory Compliance and Special Conditions of Safe Use

### Changes in Revision J—

- Revised instructions for Replacement of Filter Cartridge, pg. 41.
- Added Figures 5-1, 5-2.

### Changes in Revision H—

- Replaced torque values in Servo Valve section, Line 12, pg. 42

### Changes in Revision G—

- Most of the Regulatory Compliance section replaced and/or reordered
- Added SIL certification information to Regulatory Compliance section
- Added Chapter 6 Safety Management – Safe Position Fuel Shutoff Function
- Replaced all Declarations

### Changes in Revision F—

- Updated Declaration of Conformity and Declaration of Incorporation
- Removed GOST-R information and replaced it with EAC Customs Union information

### Changes in Revision E—

- Updated to include High Pressure Trip version. Included drawings 1-5c and 1-5d

### Changes in Revision D—

- Updated ATEX information (page v)
- Updated Declaration

### Changes in Revision C—

- Added warnings required by ATEX changes (pages vi, 28, 31)
- Updated Declaration

### Changes in Revision B—

- Updated Pressure Equipment Directive and GOST R information
- Updated Declaration of Conformity

### Changes in Revision A—

- Corrected filter torque page 32

# Declarations

## EU DECLARATION OF CONFORMITY

**EU DoC No.:** 00146-04-CE-02-03  
**Manufacturer's Name:** WOODWARD INC.  
**Manufacturer's Contact Address:** 1041 Woodward Way  
 Fort Collins, CO 80524 USA  
**Model Name(s)/Number(s):** Gas Stop/Ratio Valve, consisting of an electrohydraulic actuator and gas valve  
**The object of the declaration described above is in conformity with the following relevant Union harmonization legislation:** Directive 2014/34/EU of the European Parliament and of the Council of 26 February 2014 on the harmonization of the laws of the Member States relating to equipment and protective systems intended for use in potentially explosive atmospheres  
 Directive 2014/30/EU of the European Parliament and of the Council of 26 February 2014 on the harmonization of the laws of the Member States relating to electromagnetic compatibility (EMC)  
**Markings in addition to CE marking:**  II 3 G, Ex nA IIC T3 Gc  
**Applicable Standards:** EN 60079-0:2012: Electrical apparatus for explosive gas atmospheres – Part 0: General Requirements  
 EN 60079-15, 2010: Electrical apparatus for explosive gas atmospheres – Part 15: Type of protection 'n'  
 EN61000-6-4, 2007/A1:2011: EMC Part 6-4: Generic Standards - Emissions for Industrial Environments. (By technical evaluation, not testing, since the product is inherently benign in terms of EMC.)  
 EN61000-6-2, 2005: EMC Part 6-2: Generic Standards - Immunity for Industrial Environments. (By technical evaluation, not testing, since the product is inherently benign in terms of EMC.)

This declaration of conformity is issued under the sole responsibility of the manufacturer  
 We, the undersigned, hereby declare that the equipment specified above conforms to the above Directive(s).

MANUFACTURER

  
\_\_\_\_\_  
Signature

\_\_\_\_\_  
Full Name

\_\_\_\_\_  
Position

\_\_\_\_\_  
Place

\_\_\_\_\_  
Date

<b>DECLARATION OF INCORPORATION</b> <b>Of Partly Completed Machinery</b> <b>2006/42/EC</b>
--

**File name:** 00146-04-CE-02-01  
**Manufacturer's Name:** WOODWARD INC.  
**Manufacturer's Address:** 1041 Woodward Way  
 Fort Collins, CO 80524 USA  
**Model Names:** Gas Stop/Ratio Valve, consisting of an electrohydraulic actuator  
 and gas valve

This product complies, where applicable, with the following  
**Essential Requirements of Annex I:** 1.1, 1.2, 1.3, 1.5, 1.6, 1.7

---

The relevant technical documentation is compiled in accordance with part B of Annex VII. Woodward shall transmit relevant information if required by a reasoned request by the national authorities. The method of transmittal shall be agreed upon by the applicable parties.

The person authorized to compile the technical documentation:

**Name:** Dominik Kania, Managing Director  
**Address:** Woodward Poland Sp. z o.o., ul. Skarbowa 32, 32-005 Niepolomice, Poland

This product must not be put into service until the final machinery into which it is to be incorporated has been declared in conformity with the provisions of this Directive, where appropriate.

The undersigned hereby declares, on behalf of Woodward Inc. of Loveland and Fort Collins, Colorado that the above referenced product is in conformity with Directive 2006/42/EC as partly completed machinery:

### MANUFACTURER

Signature	
Full Name	Mike Row
Position	Engineering Supervisor
Place	Woodward Inc., Fort Collins, CO, USA
Date	20-Dec-2019



## EU DECLARATION OF CONFORMITY

Sample - Each DoC is serialized but this represents what will be supplied for V150, V200, V300, SS-260 or V500.

## Manufacturer:

Fisher Controls International, LLC  
Emerson Automation Solutions  
4725 HWY 75 South  
Sherman, TX 75090  
USA

We hereby declare that the equipment detailed below and information given are in compliance with below mentioned directives. This Declaration of Conformity is issued under the sole responsibility of the manufacturer.

Serial Number	Type	PED Directive 2014/68/EU			ATEX 2014/34/EU		EMC 2014/30/EU	Other Directives
		Modul	Categorie	PMA	Categorie	Marking		
F002222026								
Valve	Rotary Shaft	H	III	SA351-CG8M_1	2	II 2 GD TX	N/A	N/A
Actuator	N/A	N/A	N/A	N/A	N/A	N/A	N/A	

PED : Name & Address of the Notified Body monitoring the Manufacturer's QA System :  
Bureau Veritas SA, 52 Boulevard du Parc, Ile de la Jatte, 92200 Neuilly sur Seine FRANCE  
Notified Body I.D. 0062  
PED full quality assurance certificate CE-0062-PED-H-FVD 001-19-USA

ATEX : Name & Address of the Notified Body where the technical documentation has been submitted and retained :  
SGS Fimko Oy, P.O. Box 30 ( Sarkiniementie 3 ), Helsinki 00211, Finland

The object of the Declaration described above is in conformity with the relevant Union harmonization legislation.

	Harmonized standard used*	Other Technical standards used*
PED	EN1349:2009, EN19:2016, EN16668	ASME B16.34
ATEX	EN13463-1:2009, EN1127-1:2011	N/A
EMC	Refer to electrical components EU DoCs	N/A

\*Latest version of the standard applies unless otherwise noted.

Authorized person for the Manufacturer: Barry Hurst

Job Title: QA Manager

Signature:

Date:

21 May 2019

We appreciate your comments about the content of our publications.

Send comments to: [industrial.support@woodward.com](mailto:industrial.support@woodward.com)

Please reference publication **26620**.



PO Box 1519, Fort Collins CO 80522-1519, USA  
1041 Woodward Way, Fort Collins CO 80524, USA  
Phone +1 (970) 482-5811

Email and Website—[www.woodward.com](http://www.woodward.com)

Woodward has company-owned plants, subsidiaries, and branches, as well as authorized distributors and other authorized service and sales facilities throughout the world.

Complete address / phone / fax / email information for all locations is available on our website.