

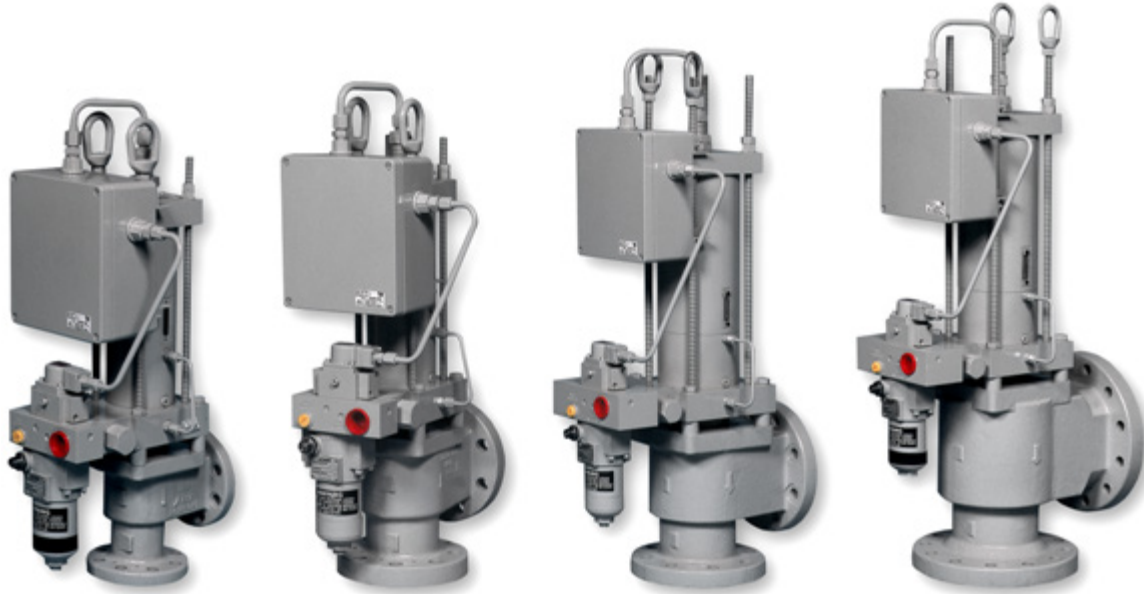

Product Manual 26703
(Revision H, 9/2025)
Original Instructions



SonicFlo™ Gas Fuel Control Valve with Electric Trip for IECEx Installation

Installation and Operation Manual



**General
Precautions**

Read this entire manual and all other publications pertaining to the work to be performed before installing, operating, or servicing this equipment.

Practice all plant and safety instructions and precautions.

Failure to follow instructions can cause personal injury and/or property damage.



Revisions

This publication may have been revised or updated since this copy was produced. The latest version of most publications is available on the Woodward website.

[Woodward Industrial Support: Get Help](#)

If your publication is not there, please contact your customer service representative to get the latest copy.



Proper Use

Any unauthorized modifications to or use of this equipment outside its specified mechanical, electrical, or other operating limits may cause personal injury and/or property damage, including damage to the equipment. Any such unauthorized modifications: (i) constitute "misuse" and/or "negligence" within the meaning of the product warranty thereby excluding warranty coverage for any resulting damage, and (ii) invalidate product certifications or listings.



**Translated
Publications**

If the cover of this publication states "Translation of the Original Instructions" please note:

The original source of this publication may have been updated since this translation was made. The latest version of most publications is available on the Woodward website.

[Woodward Industrial Support: Get Help](#)

Always compare with the original for technical specifications and for proper and safe installation and operation procedures.

If your publication is not on the Woodward website, please contact your customer service representative to get the latest copy.

Revisions— A bold, black line alongside the text identifies changes in this publication since the last revision.

Woodward reserves the right to update any portion of this publication at any time. Information provided by Woodward is believed to be correct and reliable. However, no responsibility is assumed by Woodward unless otherwise expressly undertaken.

Contents

WARNINGS AND NOTICES	3
ELECTROSTATIC DISCHARGE AWARENESS	4
REGULATORY COMPLIANCE	5
CHAPTER 1. GENERAL INFORMATION	7
Introduction.....	7
Control Valve Functional Characteristics	8
CHAPTER 2. DESCRIPTION	23
Triple Coil Electrohydraulic Servo Valve Assembly	23
Trip Relay Valve Assembly	24
Hydraulic Filter Assembly.....	24
LVDT Position Feedback Sensors	24
CHAPTER 3. INSTALLATION	25
General.....	25
Unpacking	27
Piping Installation	27
Hydraulic Connections	28
Electrical Connections.....	29
Fuel Vent Port	29
Electronic Settings	29
CHAPTER 4. MAINTENANCE AND HARDWARE REPLACEMENT	32
Maintenance.....	32
Hardware Replacement	32
Locking (Rotation) of Actuator to Valve (for 2" valves).....	37
Locking (Rotation) of Actuator to Valve (for 3", 4", and 6" valves)	38
Inspections	39
Troubleshooting	41
CHAPTER 5. SAFETY MANAGEMENT – SAFE POSITION FUEL SHUTOFF FUNCTION	44
Safety Function	44
Product Variations Certified	44
SFF (Safe Failure Fraction) for the SonicFlo™ Gas Fuel Control Valve – Over Speed SIF	44
Response Time Data	45
Limitations	45
Management of Functional Safety	45
Restrictions.....	46
Competence of Personnel.....	46
Operation and Maintenance Practice.....	46
Installation and Site Acceptance Testing	46
Functional Testing after Initial Installation	46
Functional Testing after Changes	46
Proof Test (Functional Test).....	46
Suggested Proof Test	47
Proof Test Coverage	47
CHAPTER 6. PRODUCT SUPPORT AND SERVICE OPTIONS	48
Product Support Options.....	48
Product Service Options	48
Returning Equipment for Repair	49
Replacement Parts.....	50
Engineering Services	50
Contacting Woodward's Support Organization.....	50
Technical Assistance	51

REVISION HISTORY	52
------------------------	----

Illustrations and Tables

Figure 1-1. SonicFlo Gas Fuel Control Valves (2", 3", 4", 6")	7
Figure 1-2a. Outline Drawing (2" Control Valve with Dual-Entry Box)	9
Figure 1-2b. Outline Drawing (2" Control Valve with Dual-Entry Box)	10
Figure 1-3a. Outline Drawing (3" Control Valve with Dual-Entry Box)	11
Figure 1-3b. Outline Drawing (3" Control Valve with Dual-Entry Box)	12
Figure 1-4a. Outline Drawing (3" Control Valve with Dual-Entry Box, Triple LVDT)	13
Figure 1-4b. Outline Drawing (3" Control Valve with Dual-Entry Box, Triple LVDT)	14
Figure 1-5a. Outline Drawing (4" Control Valve with Dual-Entry Box, Triple LVDT)	15
Figure 1-5b. Outline Drawing (4" Control Valve with Dual-Entry Box, Triple LVDT)	16
Figure 1-6a. Outline Drawing (3" Control Valve with Dual-Entry SST Box, Dual LVDT)	17
Figure 1-6b. Outline Drawing (3" Control Valve with Dual-Entry SST Box, Dual LVDT)	18
Figure 1-7a. Outline Drawing (4" Control Valve with Dual-Entry SST Box, Dual LVDT)	19
Figure 1-7b. Outline Drawing (4" Control Valve with Dual-Entry SST Box, Dual LVDT)	20
Figure 1-7c. Hydraulic Schematic Circuit	21
Figure 1-8a. Wiring Diagram - Dual LVDT	22
Figure 1-8b. Wiring Diagram - Triple LVDT	22
Figure 2-1. Servo Valve Cutaway	23
Figure 3-1. Illustration of Diverging Sleeve Screws	26
Figure 3-2. Illustration of Raised Face Style Diverging Sleeve	26
Figure 3-3. Illustration of Extension Style Diverging Sleeve	27
Figure 3-4. Gas Fuel Control Valve Block Diagram	30
Figure 3-5. Structures for PID Control	31
Figure 4-1a. Inspection Areas for 2 Inch Valves	39
Figure 4-1b. Inspection Areas for 3, 4, and 6 Inch Valves	40
Figure 4-2. Location of Hydraulic Interseal Drain and Cap for 2 Inch Valves	40
Table 3-1. Class 300 Flange Fastener Specifications	28
Table 3-2. Bolt Size and Torque Specifications	28
Table 3-3. Recommended Control Gain Values for Different Control Types	31
Table 4-1. Troubleshooting Symptoms, Possible Causes, and Remedies	42
Table 5-1. Failure Rates according to IEC 61508 in FIT	45
Table 5-2. Suggested Proof Test	47
Table 5-3. Proof Test Coverage	47

Warnings and Notices

Important Definitions



This is the safety alert symbol used to alert you to potential personal injury hazards. Obey all safety messages that follow this symbol to avoid possible injury or death.

- **DANGER** - Indicates a hazardous situation, which if not avoided, will result in death or serious injury.
- **WARNING** - Indicates a hazardous situation, which if not avoided, could result in death or serious injury.
- **CAUTION** - Indicates a hazardous situation, which if not avoided, could result in minor or moderate injury.
- **NOTICE** - Indicates a hazard that could result in property damage only (including damage to the control).
- **IMPORTANT** - Designates an operating tip or maintenance suggestion.

WARNING

**Overspeed /
Overtemperature /
Overpressure**

The engine, turbine, or other type of prime mover should be equipped with an overspeed shutdown device to protect against runaway or damage to the prime mover with possible personal injury, loss of life, or property damage.

The overspeed shutdown device must be totally independent of the prime mover control system. An overtemperature or overpressure shutdown device may also be needed for safety, as appropriate.

WARNING

**Personal Protective
Equipment**

The products described in this publication may present risks that could lead to personal injury, loss of life, or property damage. Always wear the appropriate personal protective equipment (PPE) for the job at hand. Equipment that should be considered includes but is not limited to:

- Eye Protection
- Hearing Protection
- Hard Hat
- Gloves
- Safety Boots
- Respirator

Always read the proper Material Safety Data Sheet (MSDS) for any working fluid(s) and comply with recommended safety equipment.

WARNING

Start-up

Be prepared to make an emergency shutdown when starting the engine, turbine, or other type of prime mover, to protect against runaway or overspeed with possible personal injury, loss of life, or property damage.

Electrostatic Discharge Awareness

NOTICE

Electrostatic Precautions

Electronic controls contain static-sensitive parts. Observe the following precautions to prevent damage to these parts:

- Discharge body static before handling the control (with power to the control turned off, contact a grounded surface and maintain contact while handling the control).
- Avoid all plastic, vinyl, and Styrofoam (except antistatic versions) around printed circuit boards.
- Do not touch the components or conductors on a printed circuit board with your hands or with conductive devices.

To prevent damage to electronic components caused by improper handling, read and observe the precautions in Woodward manual **82715**, *Guide for Handling and Protection of Electronic Controls, Printed Circuit Boards, and Modules*.

Follow these precautions when working with or near the control.

1. Avoid the build-up of static electricity on your body by not wearing clothing made of synthetic materials. Wear cotton or cotton-blend materials as much as possible because these do not store static electric charges as much as synthetics.
2. Do not remove the printed circuit board (PCB) from the control cabinet unless absolutely necessary. If you must remove the PCB from the control cabinet, follow these precautions:
 - Do not touch any part of the PCB except the edges.
 - Do not touch the electrical conductors, the connectors, or the components with conductive devices or with your hands.
 - When replacing a PCB, keep the new PCB in the plastic antistatic protective bag it comes in until you are ready to install it. Immediately after removing the old PCB from the control cabinet, place it in the antistatic protective bag.

Regulatory Compliance

International Compliance

IECEX: For IECEx Marked Valves:
Certified for use in explosive atmospheres per Certificate: IECEx ETL
25.0031X

RoHS Directive: Restriction of Hazardous Substances 2011/65/EU:
Woodward Turbomachinery Systems products are intended exclusively for sale and use only as a part of Large Scale Fixed Installations per the meaning of Art.2.4(e) of directive 2011/65/EU. This fulfills the requirements stated in Art.2.4(c) and as such the product is excluded from the scope of RoHS2.

SIL Compliance:

SIL certification is available for specific Woodward item numbers. Please contact a Woodward representative for assistance.



SonicFlo™ Gas Fuel Control Valve – Certified SIL 3 Capable for safe position fuel shutoff function in safety instrumented systems. Evaluated to IEC 61508 Parts 1-7. Refer to the instructions of this Installation and Operation Manual, Chapter 5 – Safety Management – Safe Position Fuel Shutoff Function.

SIL Certificate WOO 17-04-071 C001

[Link to exida SIL 3 Certification](#)

Special Conditions for Safe Use—All Valves

Wiring must be in accordance with North American Class I, Division 2, or European Zone 2 Category 3 wiring methods as applicable, and in accordance with the authority having jurisdiction.

Field Wiring must be suitable for at least 100 °C.

The wiring junction box provides earth ground terminals if needed for a separate earth ground to meet wiring requirements.

For IECEx Marked Valves:

1. The wiring junction box provides earth ground terminals if needed for a separate earth ground to meet wiring requirements.
2. T3 reflects conditions without process fluid. The surface temperature of this valve approaches the maximum temperature of the applied process media. It is the responsibility of the user to ensure that the external environment contains no hazardous gases capable of ignition in the range of the process media temperatures.
3. The risk of electrostatic discharge is reduced by permanent installation of the valve, proper connection to the protective earth (PE) terminals, and care when cleaning. The valve should not be cleaned unless the area is known to be non-hazardous.
4. The screwed cable connector may only be disconnected when the circuit is de-energized or when the location is known to be non-hazardous.

**WARNING**

EXPLOSION HAZARD—Do not connect or disconnect while circuit is live unless area is known to be non-hazardous.

Substitution of components may impair suitability for Class I, Division 2 or Zone 2.

**AVERTISSEMENT**

RISQUE D'EXPLOSION—Ne pas raccorder ni débrancher tant que l'installation est sous tension, sauf en cas l'ambiance est décidément non dangereuse.

La substitution de composants peut rendre ce matériel inacceptable pour les emplacements de Classe I, Division 2 ou Zone 2.

Chapter 1.

General Information

Introduction

The SonicFlo™ valve controls the flow of gas fuel to the combustion system of an industrial or utility gas turbine. The unique design yields a linear flow characteristic unaffected by discharge pressure up to a pressure ratio ($P2/P1$) of at least 0.8. The design also integrates the valve and actuator into a compact assembly. The key characteristics of this valve are a highly linear critical gas flow versus stroke relationship at constant upstream pressure. The integral actuator is a single-acting spring-loaded design for failsafe operation. The actuator includes an onboard hydraulic filter for last chance filtration of the fluid to ensure reliability of the servo valve and actuator. The servo valve is electrically redundant with triple coil design. Feedback for the actuator is provided by a dual coil, dual rod LVDT (linear variable differential transformer), or triple coil, single rod LVDT directly coupled to the hydraulic piston.

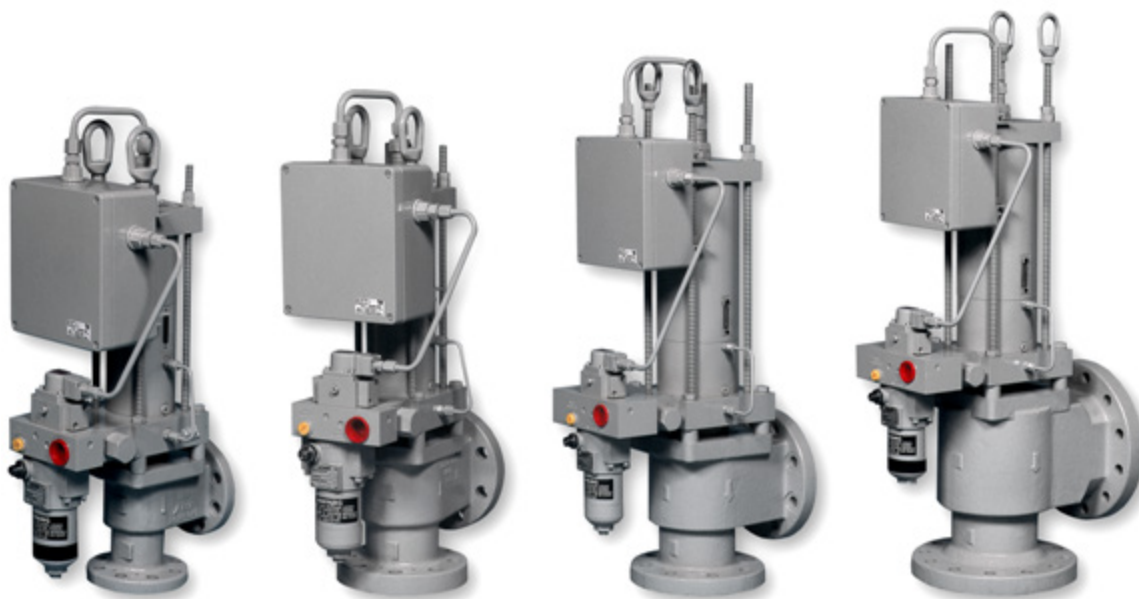

Figure 1-1. SonicFlo Gas Fuel Control Valves (2", 3", 4", 6")

Control Valve Functional Characteristics

Valve Type	Two Way—Right Angle per ASME B16.34-1996
Trim Configuration	Exponential (to yield linear flow with decreasing pressure differential)
Type of Operation	Run—Valve Open Trip—Valve Closed
Fluid Ports	ASME B16.5-1996 Class 300 flanges Size 2, 3, 4, 6 inch (51, 76, 102, 152 mm)
Flowing Media	Natural gas
Maximum Gas Pressure	250 to 500 psig/1724 to 3448 kPa (working at 450 psig/3103 kPa)
Valve Proof Pressure Level	Per ANSI B16.34, ANSI B16.37/ISA S75.19
Minimum Valve Burst Pressure	3700 psig/25 510 kPa (based on 740 psig/5102 max working pressure of class 300 flange)
Gas Filtration	25 μ m absolute at 75 beta requirement
Gas Temperature	0 to +400 °F (–18 to +204 °C)
Valve Port Sizes and Available Cg's	2" (50 mm)—Cg = 1200 3" (75 mm)—Cg = 2900
Flow Characteristics	\pm 3% Cg deviation of point from 10% to 100% stroke
Valve Ambient Temperature	–20 to +180 °F (–29 to +82 °C)
Shut-off Classification	Class IV per ANSI B16.104/FCI 70-2 (0.01% of rated valve capacity at full travel measured with air at 50 psid/ 345 kPa)
External Leakage	None
Inter-seal Vent Leakage	< 20 cc/min as shipped
Position Accuracy	\pm 1% of full scale (Over \pm 25 °F/ \pm 14 °C deviation from calibration)
Position Repeatability	\pm 0.5% of point over range of 10% to 100%
Hydraulic Fluid Type	Petroleum based hydraulic fluids
Maximum Hydraulic Supply Pressure	1200 to 1700 psig/8274 to 11 722 kPa (design at 1600 psig/11 032 kPa)
Proof Test Fluid Pressure Level	2550 psig/17 582 kPa minimum per SAE J214
Minimum Burst Fluid Pressure	4250 psig/29 304 kPa minimum per SAE J214
Fluid Filtration Required	10–15 μ m absolute
Hydraulic Fluid Temperature	+50 to +150 °F (+10 to +66 °C)
Trip Time	Less than 0.200 s
Slew Time	0 to 100% in 0.1 to 0.8 sec
Design Availability Objective	Better than 99.5% over an 8760 hour period
Hydraulic Fluid Connections	Supply pressure—0.750-14 UNF straight thread port (–8) Drain pressure—1.312-20 UNF straight thread port (–16)
Sound Level	<100 dB at max flow conditions
Vibration Test Level	0.5 gp 5–100 Hz sine wave Random 0.01500 gr ² /Hz from 10 to 40 Hz ramping down to 0.00015 gr ² /Hz at 500 Hz
Shock	Limited to 30 g by servo valve
Servo Input Current Rating	–7.2 to +8.8 mA (null bias 0.8 \pm 0.32 mA)
Hydraulic Fluid Contamination Level	Per ISO 4406 code 18/16/13 max Code 16/14/11 preferred
Trip Solenoid Voltage	90–140 Vdc (125 Vdc nominal)
Materials	Woodward certifies that our SonicFlo line of Gas Fuel Control Valves is designed and manufactured such that all wetted materials that experience a tensile stress are compliant with the thermo-mechanical requirements of NACE MR0175/ISO 15156 and MR0103.

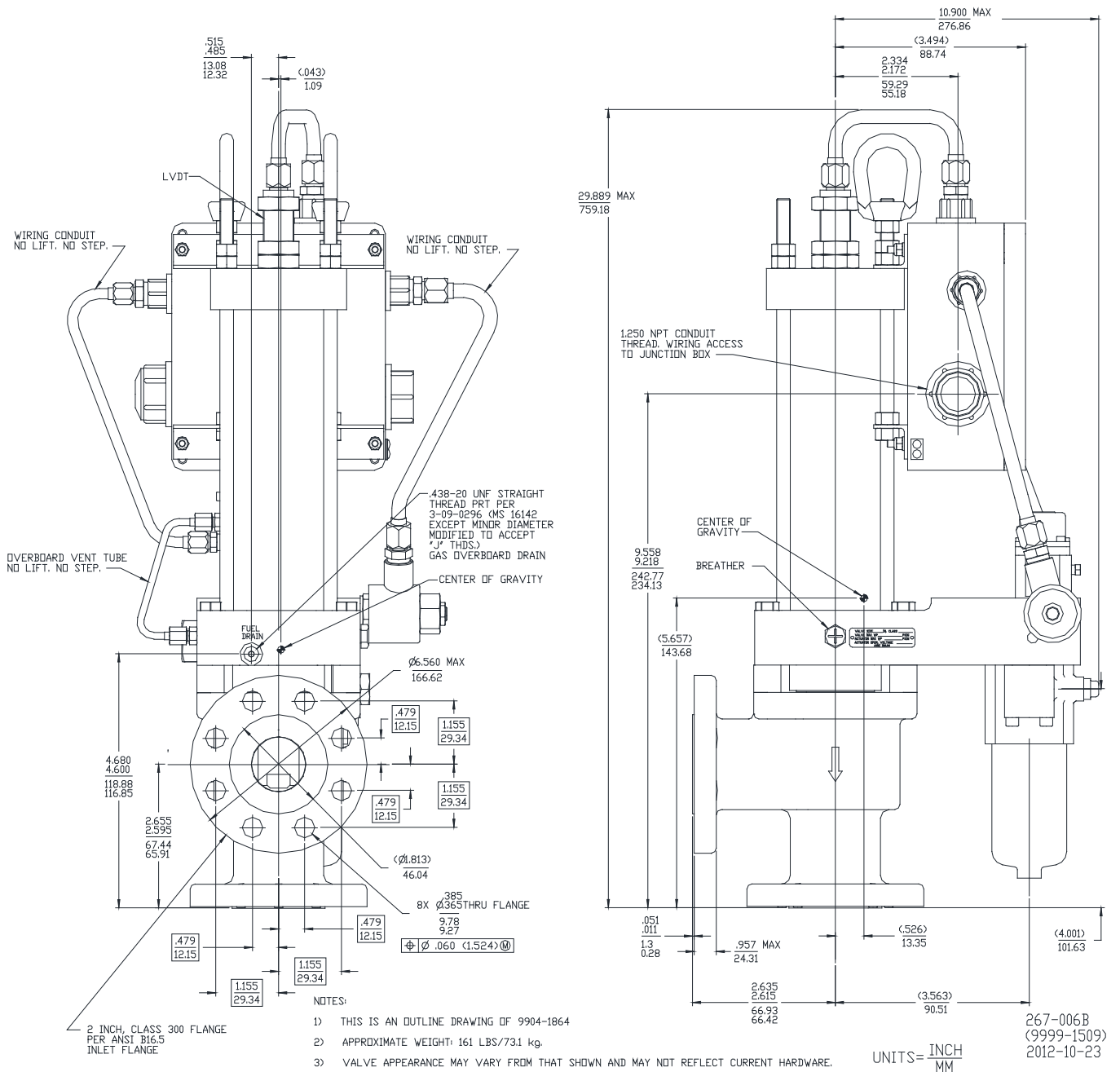
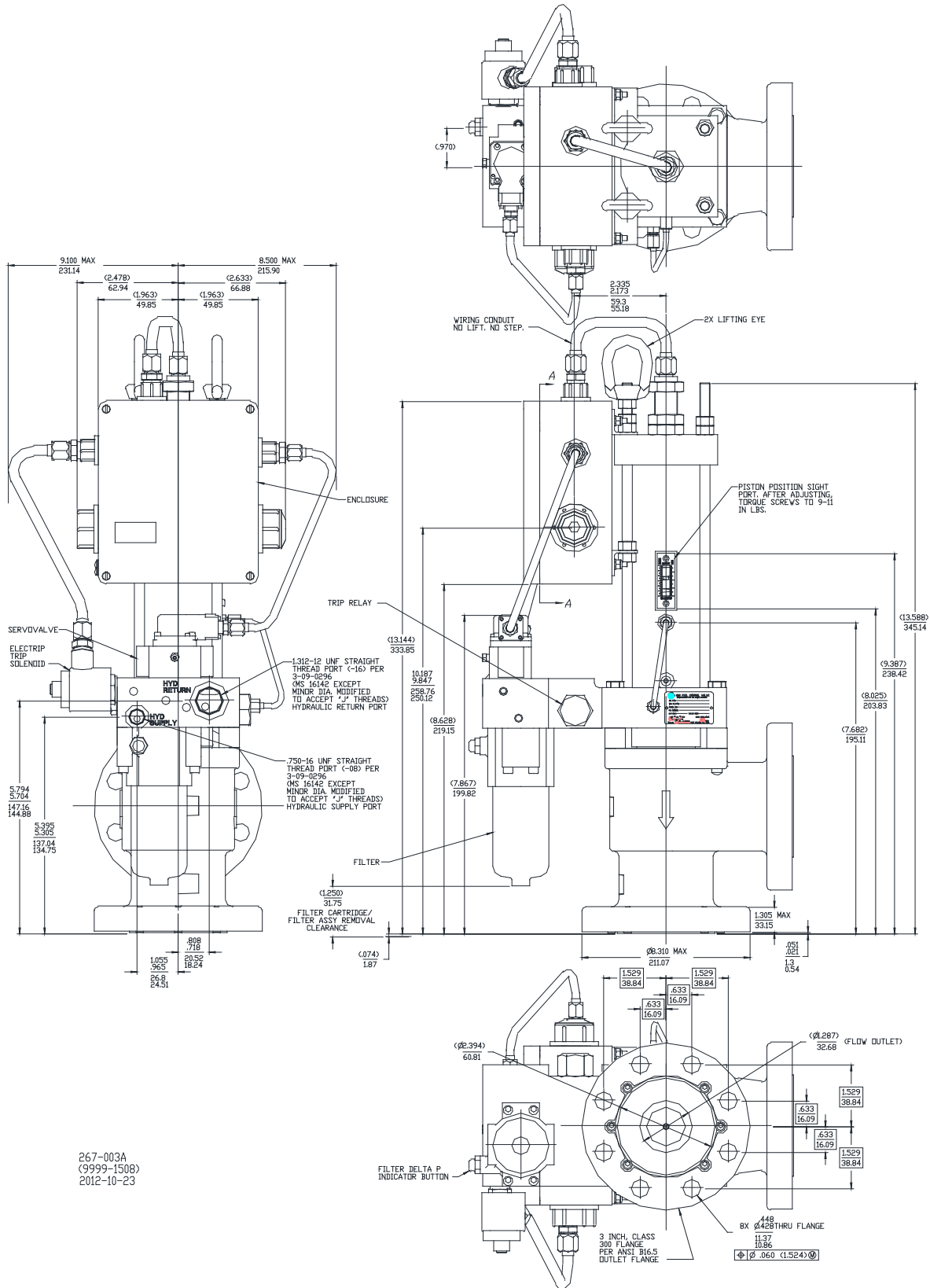

Figure 1-2b. Outline Drawing (2" Control Valve with Dual-Entry Box)



267-003A
(9999-1508)
2012-10-23

Figure 1-3a. Outline Drawing (3" Control Valve with Dual-Entry Box)

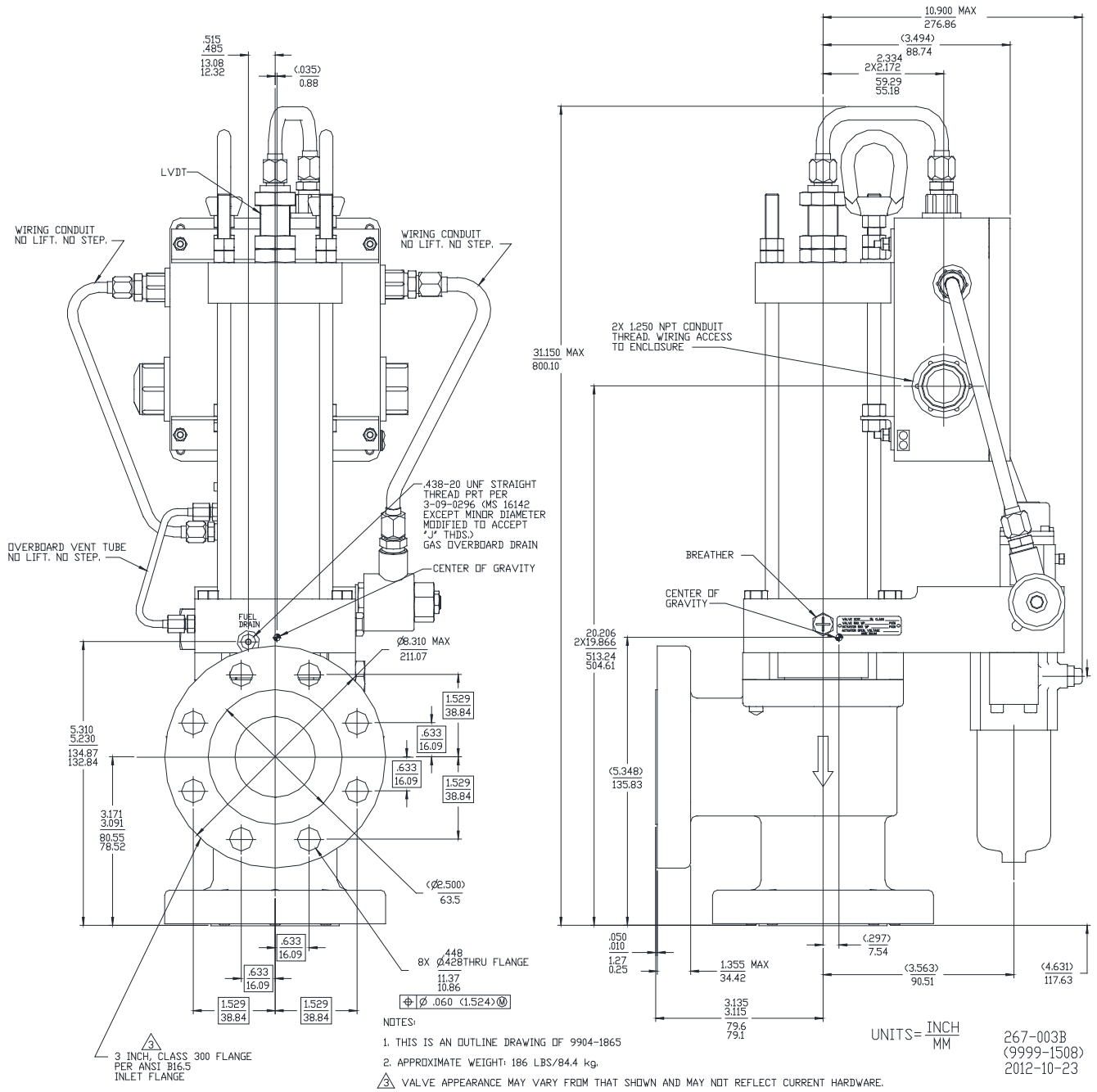

Figure 1-3b. Outline Drawing (3" Control Valve with Dual-Entry Box)

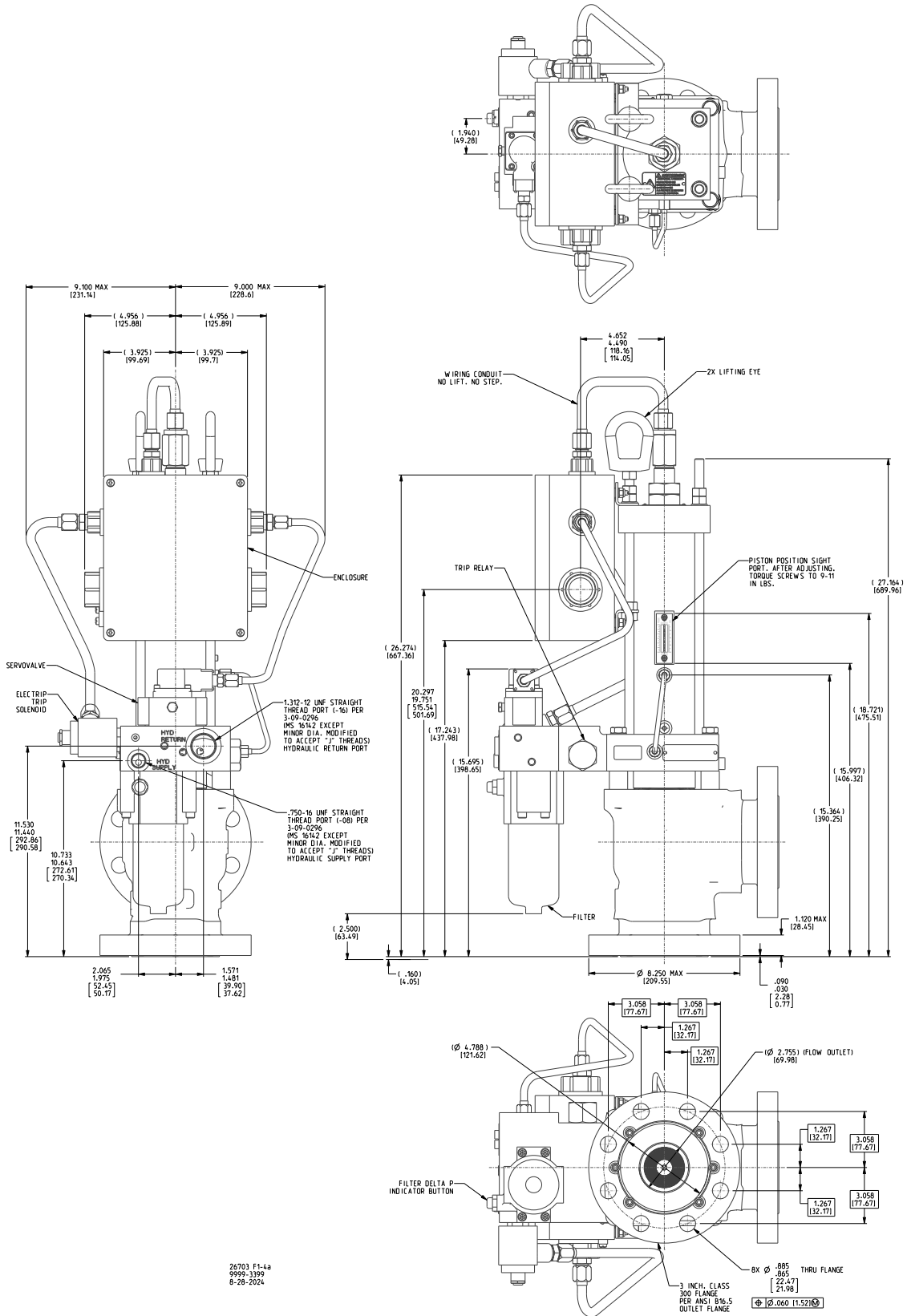

Figure 1-4a. Outline Drawing (3" Control Valve with Dual-Entry Box, Triple LVDT)

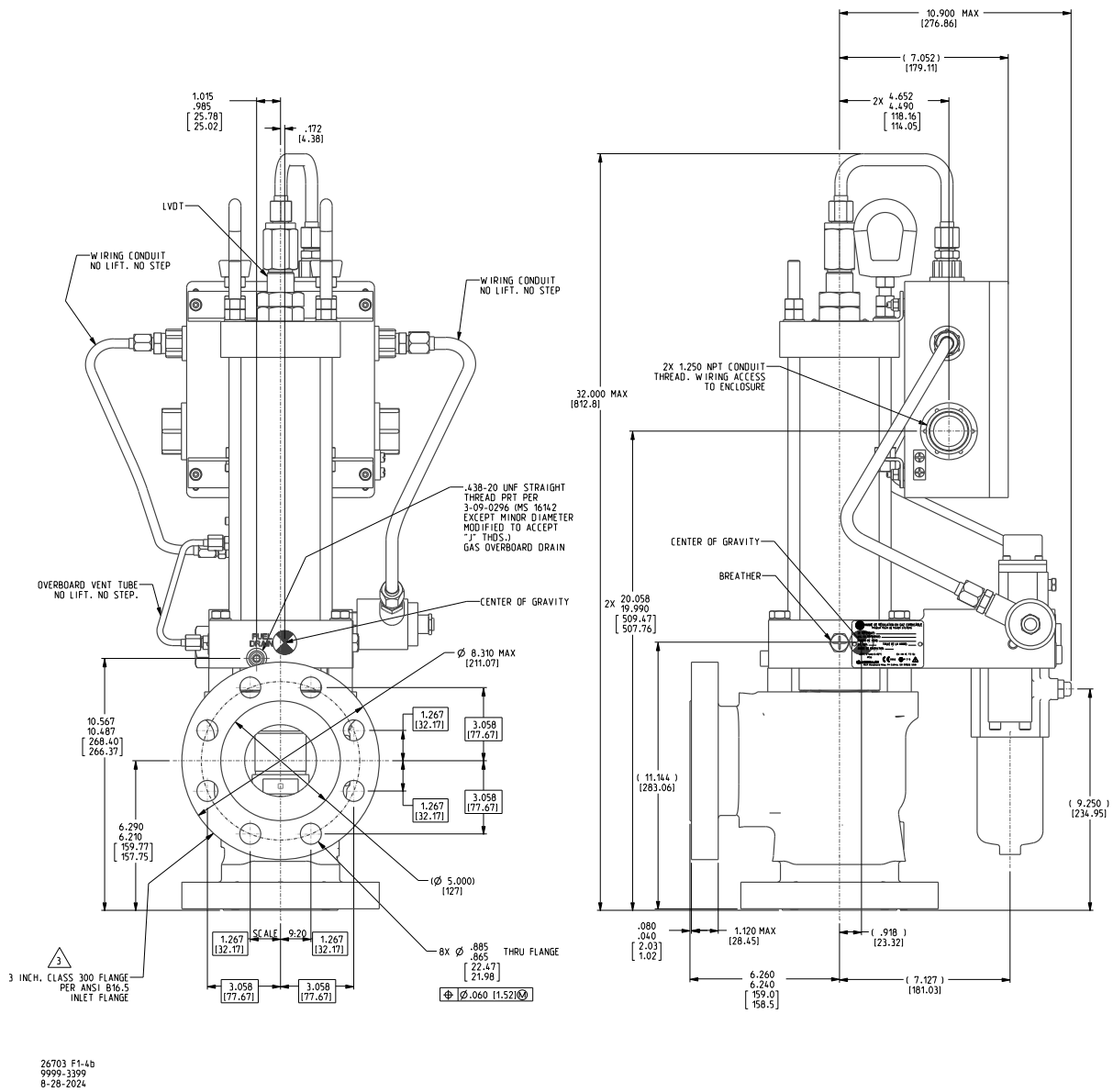

Figure 1-4b. Outline Drawing (3" Control Valve with Dual-Entry Box, Triple LVDT)

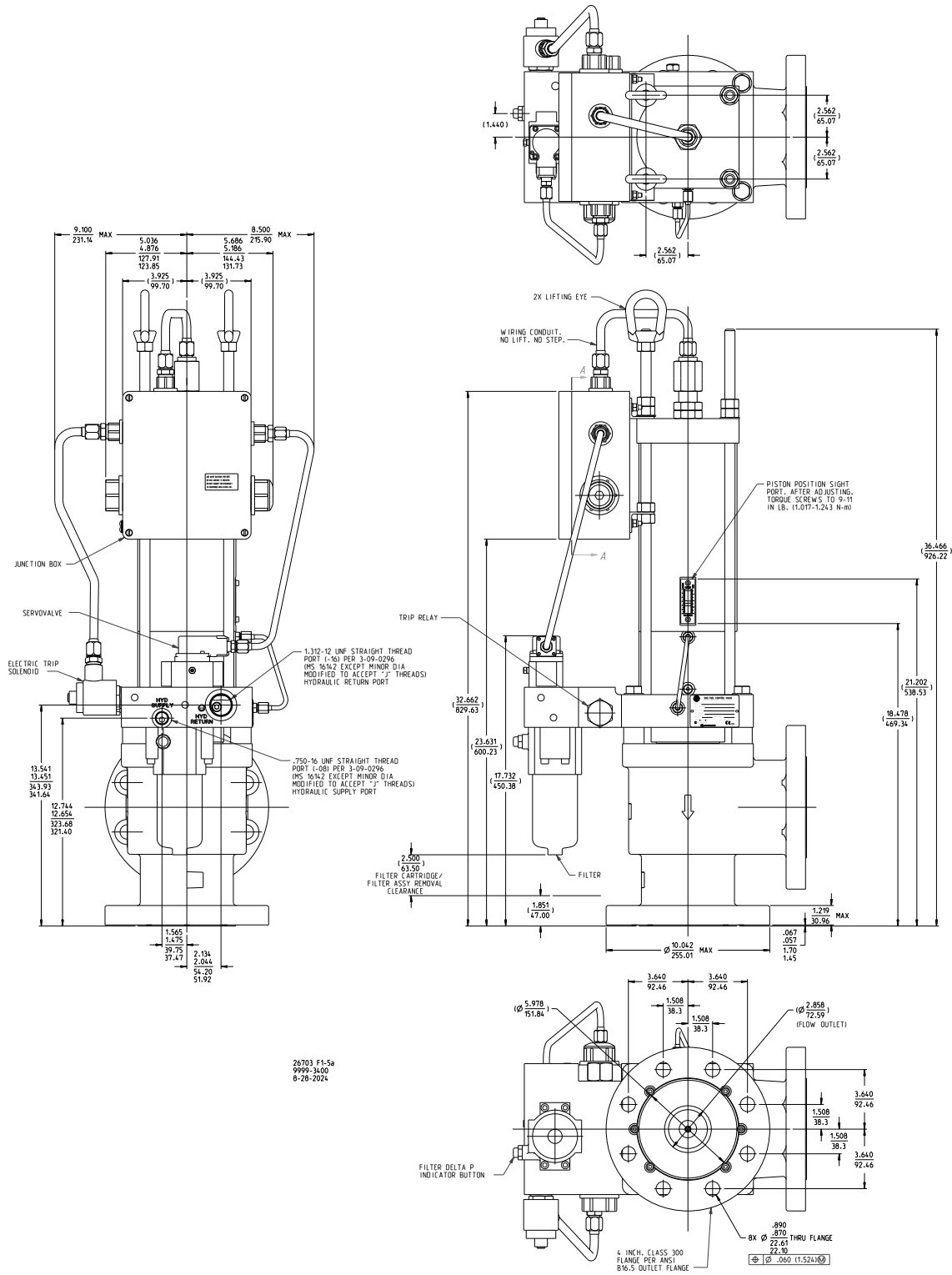

Figure 1-5a. Outline Drawing (4" Control Valve with Dual-Entry Box, Triple LVDT)

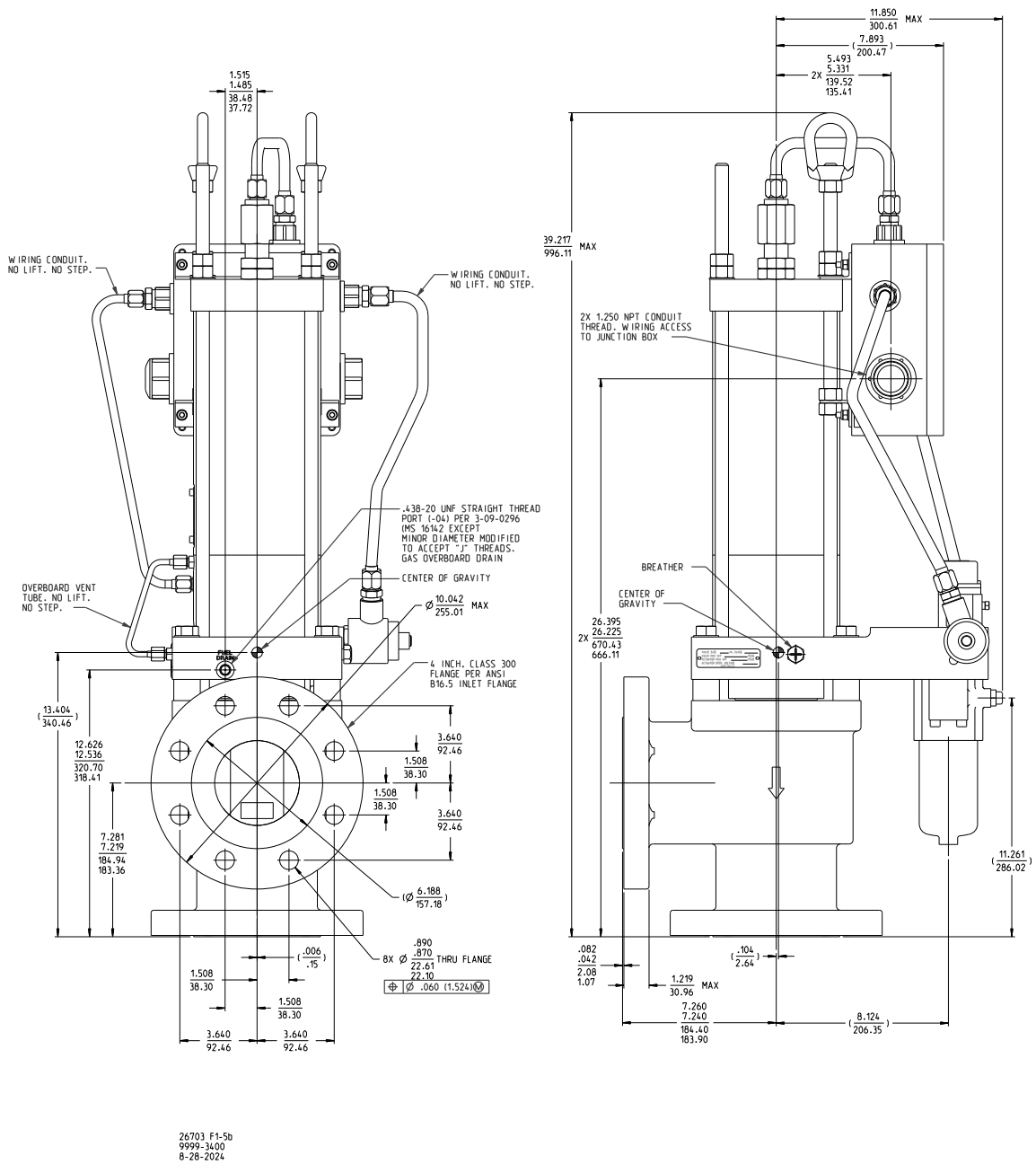

Figure 1-5b. Outline Drawing (4" Control Valve with Dual-Entry Box, Triple LVDT)

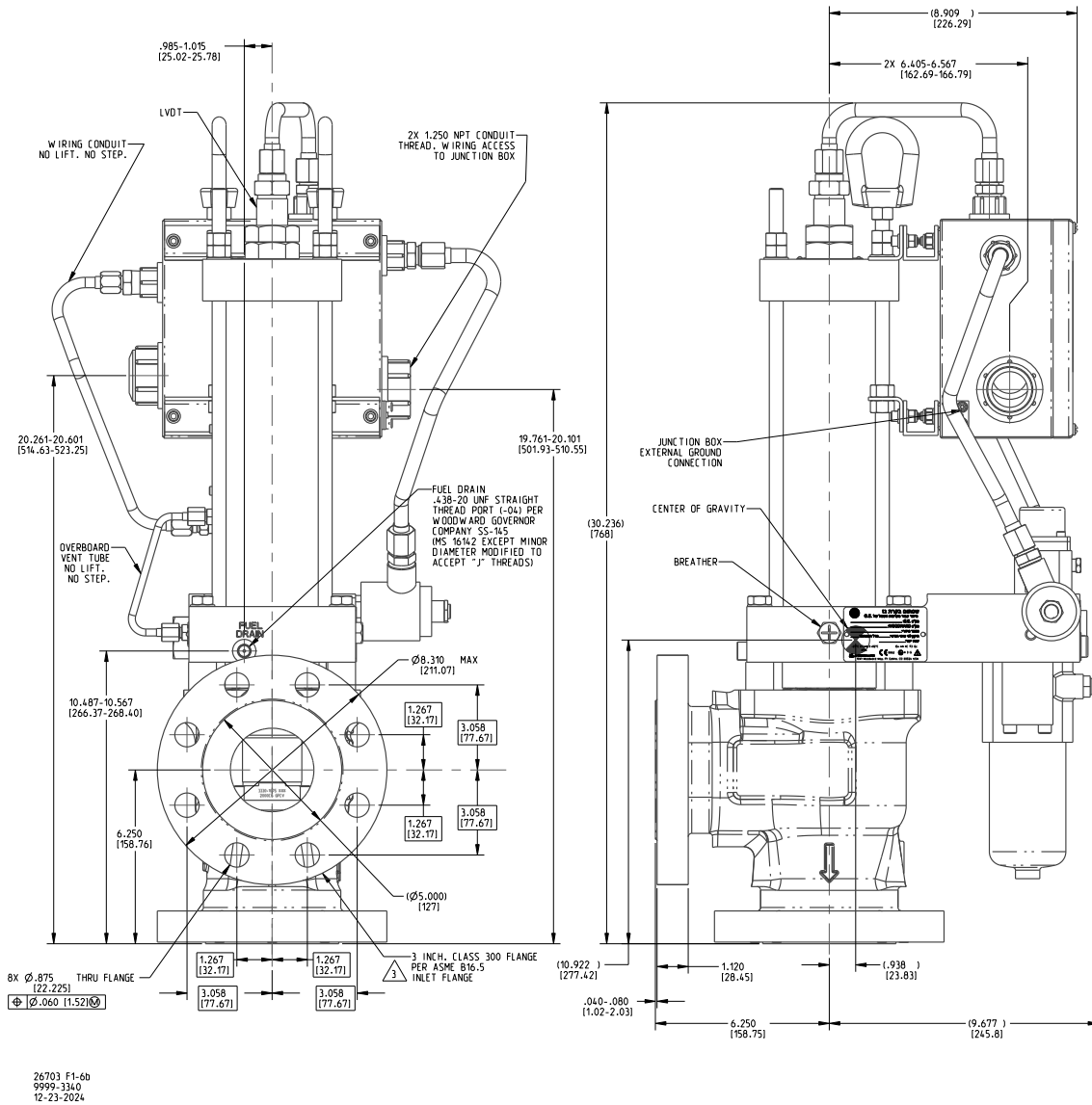

Figure 1-6b. Outline Drawing (3" Control Valve with Dual-Entry SST Box, Dual LVDT)

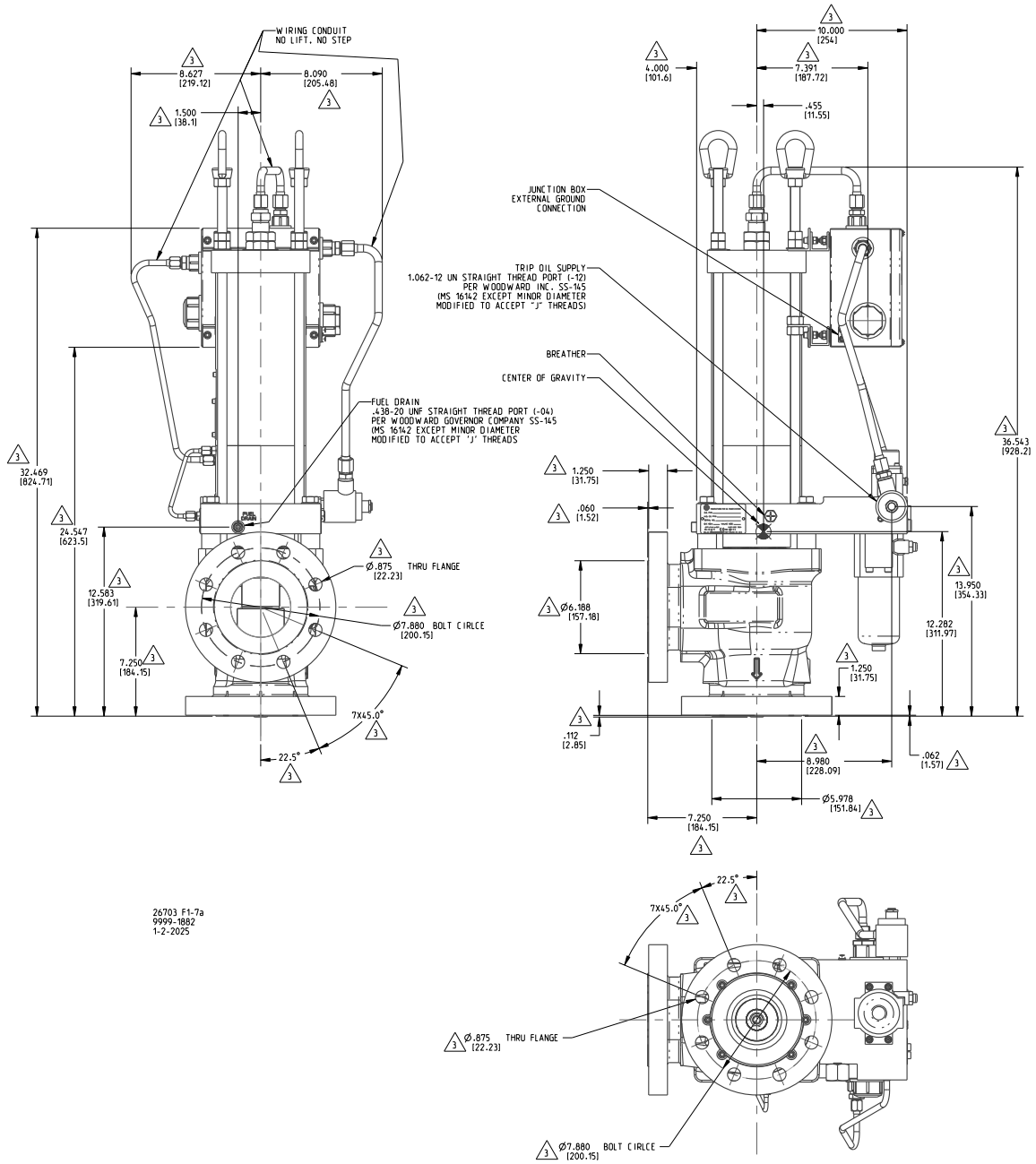

Figure 1-7a. Outline Drawing (4" Control Valve with Dual-Entry SST Box, Dual LVDT)

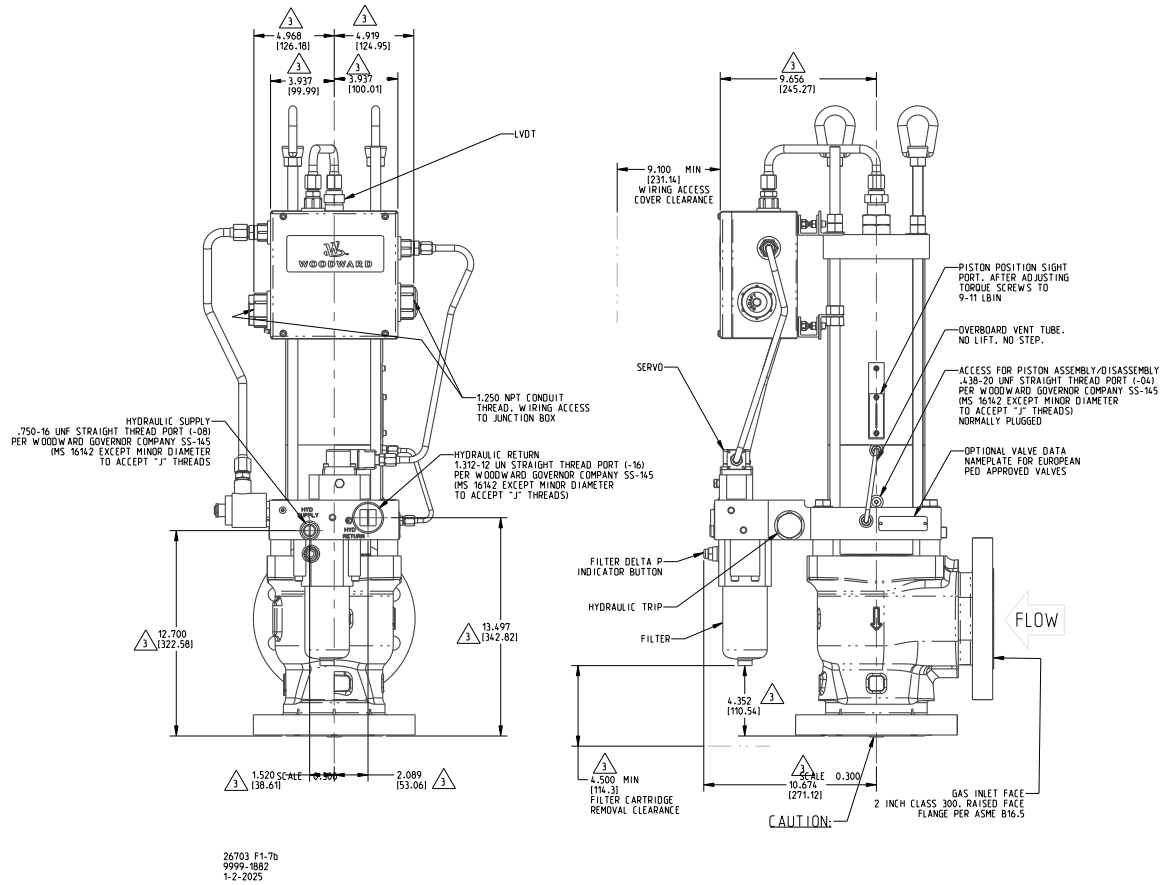

Figure 1-7b. Outline Drawing (4" Control Valve with Dual-Entry SST Box, Dual LVDT)

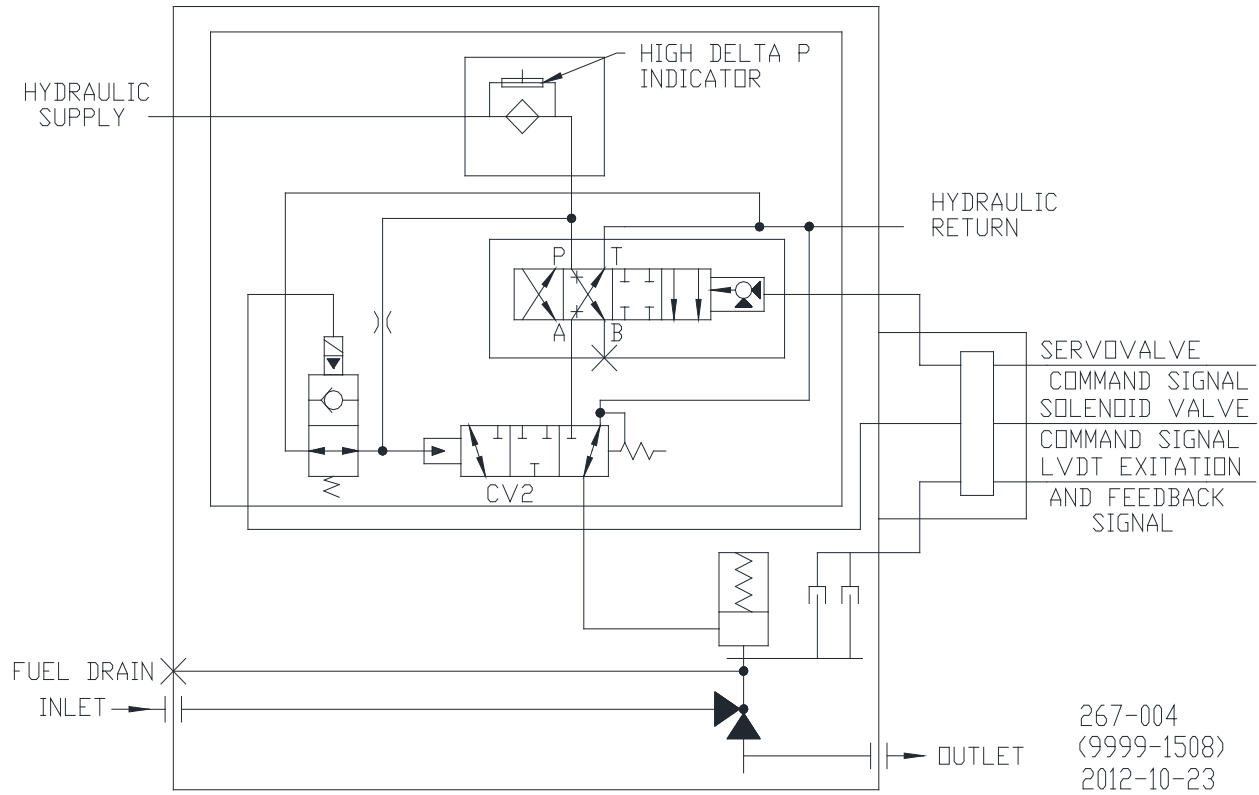

Figure 1-7c. Hydraulic Schematic Circuit

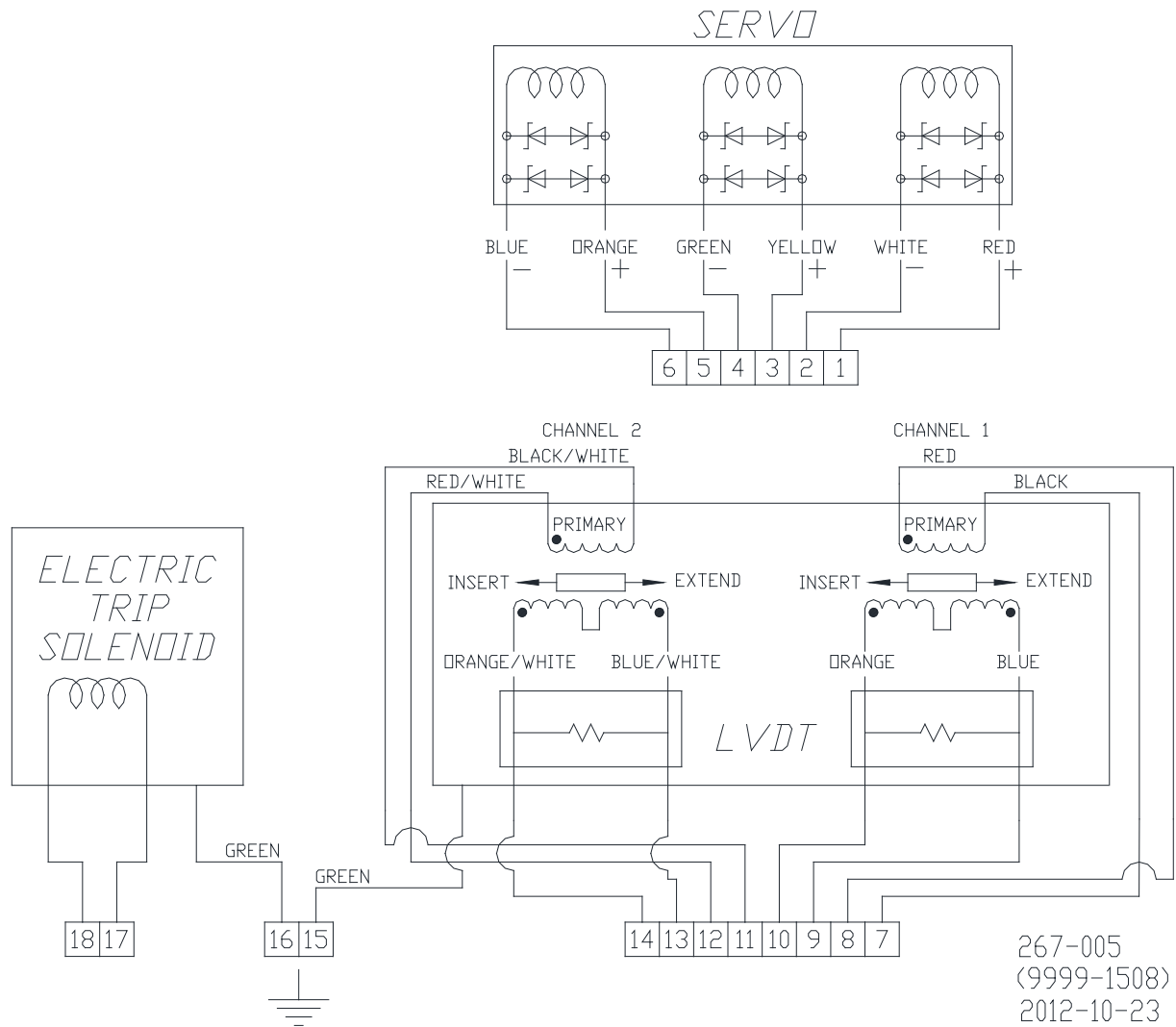
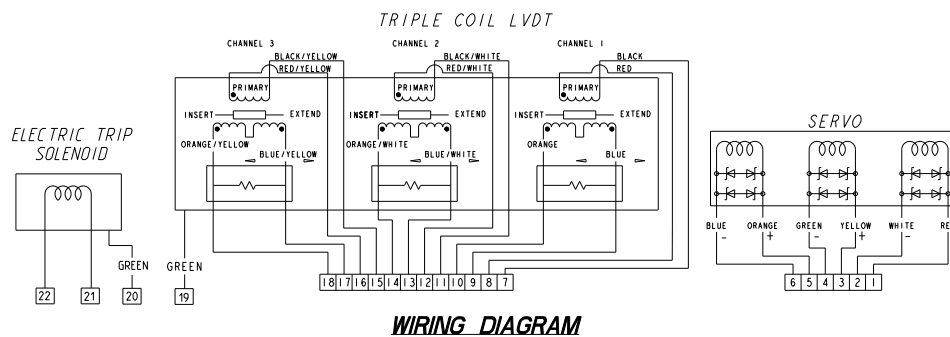

Figure 1-8a. Wiring Diagram - Dual LVDT



26703 F1-6b
9999-3400
8-28-24

Figure 1-8b. Wiring Diagram - Triple LVDT

Chapter 2. Description

Triple Coil Electrohydraulic Servo Valve Assembly

The hydraulic actuator assembly uses a two-stage hydraulic servo valve to modulate the position of the actuator output shaft and thereby control the gas fuel valves. The first stage torque motor utilizes a triple-wound coil, which controls the position of the first and second stage valves in proportion to the total electric current applied to the three coils.

If the control system requires a rapid movement of the valve to send more fuel to the turbine, total current is increased well above the null current. In such a condition, control port PC1 is connected to supply pressure. The flow rate delivered to the piston cavity of the actuator is proportional to the total current applied to the three coils. Thus, the opening velocity is also proportional to the current (above null) supplied to the torque motor.

If the control system requires a rapid movement to close the gas fuel valve, the total current is reduced well below the null current. In such a condition, port PC1 is connected to the hydraulic drain circuit. The flow rate from the piston cavity to drain is proportional to the magnitude of the total current below the null value. Thus, the closing velocity is also proportional to the current (below null) supplied to the torque motor.

Near the null current, the four-landed valve isolates the control port from the hydraulic supply and drain, balancing the piston pressure against the spring to maintain a constant position. The control system, which regulates the amount of current delivered to the coils, modulates the current supplied to the coil to obtain proper closed loop position of the valve.

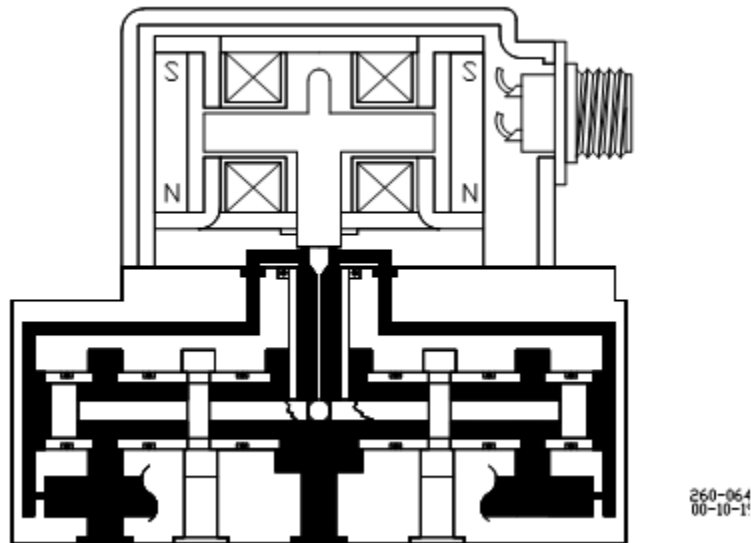

Figure 2-1. Servo Valve Cutaway

Trip Relay Valve Assembly

The SonicFlo™ valve uses a solenoid-operated trip relay circuit to operate a high capacity, three-way, two-position, hydraulically operated valve. This trip relay circuit consists of four functional elements: the trip relay solenoid valve, the trip relay supply orifice, the hydraulically operated trip valve, and the trip relay volume.

In the normal run mode, the trip relay solenoid valve is closed, which prevents the trip relay volume from bleeding to the hydraulic return. As a result, high-pressure oil is fed into the trip relay circuit through the supply orifice, which quickly pressurizes the trip circuit to supply pressure. When the trip circuit pressure increases above 1100 kPa (160 psig), the three-way relay valve shifts position so that the common port connects the control port of the servo-valve to the lower piston cavity of the actuator, allowing the servo-valve to position the throttle valve.

The solenoid valve opens when it is de-energized. Opening the solenoid valve causes the trip circuit to be connected to drain. This in turn causes the three-way relay valve to shift position so that the common port is connected to the hydraulic drain circuit, and isolated from the hydraulic supply. As the pressure falls within the lower piston cavity, the return spring rapidly returns the valve plug to the downward position, closing the control valve and shutting off fuel to the engine.

Hydraulic Filter Assembly

The valve is supplied with an integrated, high-capacity filter. The broad range filter protects the internal hydraulic control components from large oil-borne contaminants that might cause the hydraulic components to stick or operate erratically. The filter is supplied with a visual indicator which shows when the recommended pressure differential has been exceeded and thus replacement of the element is necessary.

LVDT Position Feedback Sensors

The SonicFlo control valves use a dual-coil, dual-rod LVDT, or triple coil, single rod LVDT for position feedback. The LVDT is factory set to give 0.7 Vrms feedback at minimum position and 3.5 Vrms feedback at maximum position, when supplied with 7 Vrms excitation at 3000 Hz.

Chapter 3. Installation

General

See the outline drawings (Figures 1-2 & 1-3) for:

- Overall dimensions
- Process piping flange locations
- Hydraulic fitting sizes
- Electrical connections
- Lift points and center of gravity
- Weight of the valve

Installation attitude does not affect actuator or fuel valve performance, but a vertical position is generally preferred to conserve floor space as well as ease of making electrical, fuel, and hydraulic connections and changing the hydraulic filter element. The gas fuel control valve is designed for support by the piping flanges alone; additional supports are neither needed nor recommended. Do not use this valve to provide support to any component other than the piping to which it is directly connected.

The orientation of the visual position indicator may be changed to accommodate surrounding obstructions, if any. See Chapter 4 for instructions to change the orientation.



EXPLOSION HAZARD—The surface temperature of this valve approaches the maximum temperature of the applied process media. It is the responsibility of the user to ensure that the external environment contains no hazardous gases capable of ignition in the range of the process media temperature.



External fire protection is not provided in the scope of this product. It is the responsibility of the user to satisfy any applicable requirements for their system.



Do not operate the valve without proper support for the diverging sleeve. **IF BENCH TESTING THE VALVE, ENSURE THAT ASME/ANSI RATED FLANGES ARE GASKETED AND INSTALLED OVER THE INLET AND DISCHARGE FLANGES WITH THE BOLTS PROPERLY TORQUED.** The diverging sleeve screws by themselves are not designed to hold pressure loads. Failure to comply with this warning may result in personal injury. Do not place hands inside valve body during inspection, cleaning, or operation.



Figure 3-1. Illustration of Diverging Sleeve Screws

Diverging Sleeve assembly screws are not designed to hold pressure loads. If bench testing, do not apply pressure to the valve without ANSI flanges (see below figures).

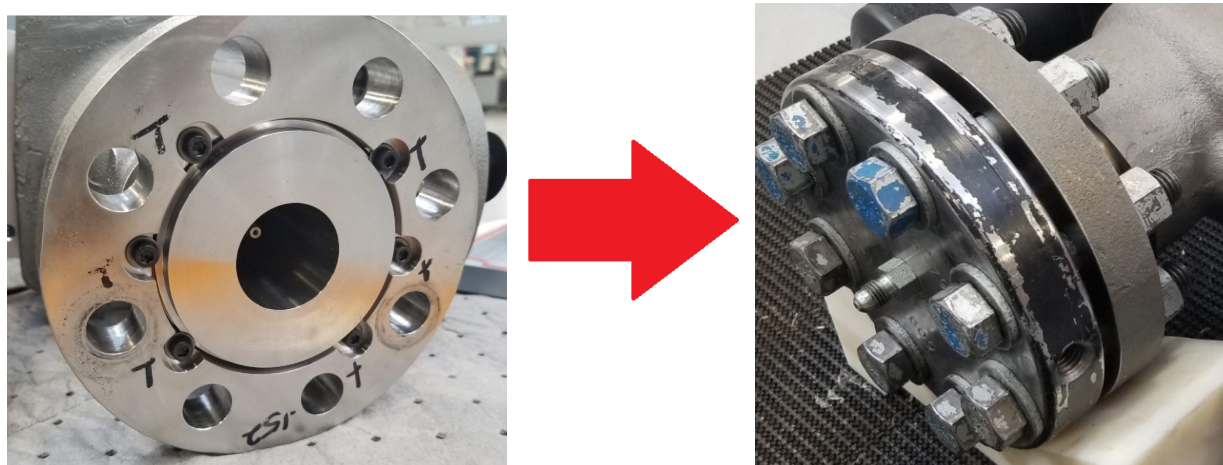

Figure 3-2. Illustration of Raised Face Style Diverging Sleeve

Raised Face style diverging sleeves should be secured with a blind flange when bench testing

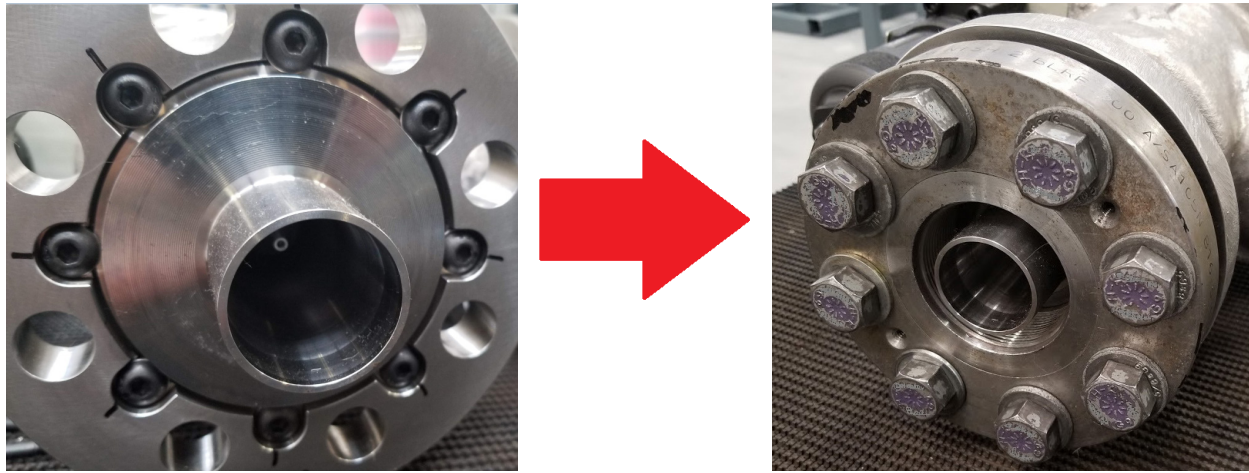

Figure 3-3. Illustration of Extension Style Diverging Sleeve

Extension style diverging sleeves should be secured with a threaded or weld neck style flange when bench testing.

! WARNING

Due to typical noise levels in turbine environments, hearing protection should be worn when working on or around the SonicFlo™ valve.

! WARNING

Do not lift or handle the valve by any conduit. Lift or handle the valve only by using the eyebolts. Use a “Y” type lifting configuration to prevent damage to the LVDT conduit.

! WARNING

The surface of this product can become hot enough or cold enough to be a hazard. Use protective gear for product handling in these circumstances. Temperature ratings are included in the specification section of this manual.

Unpacking

The valve is shipped in an airtight bag with desiccant to ensure a non-corrosive environment. We recommend that the valve be kept in its shipping container until installation. If the valve is to be stored for extended periods of time, encase the valve in an airtight container with desiccant.

Piping Installation

Refer to ASME B16.5 for details of flange, gasket, and bolt types and dimensions. The gas fuel control valve is designed for support by the piping flanges alone; additional supports are neither needed nor recommended.

This is a 90° angle valve. Verify that the process piping centerline-to-flange-face dimensions meet the requirements of the outline drawings (Figures 1-2 & 1-3) within standard piping tolerances. The valve should mount between the piping interfaces such that the flange bolts can be installed with only manual pressure applied to align the flanges. Mechanical devices such as hydraulic or mechanical jacks, pulleys, chain-falls, or similar should never be used to force the piping system to align with the valve flanges.

ASTM/ASME grade bolts or studs should be used to install the valve into the process piping. The length and diameter for Class 300 flanges shall conform to the following table according to the valve flange size.

Table 3-1. Class 300 Flange Fastener Specifications

Nominal Pipe Size	Number of Bolts	Diameter of Bolts	Stud Length	Machine Bolt Length
1 inch/ 25 mm	4	5/8 inch/ 16 mm	3.00 inch/ 76.2 mm	2.50 inch/ 63.5 mm
2 inch/ 51 mm	8	5/8 inch/ 16 mm	3.50 inch/ 88.9 mm	3.00 inch/ 76.2 mm
3 inch/ 76 mm	8	3/4 inch/ 19 mm	4.25 inch/ 108.0 mm	3.50 inch/ 88.9 mm
4 inch/ 102 mm	8	3/4 inch/ 19 mm	4.50 inch/ 114.3 mm	3.75 inch/ 95.2 mm
6 inch/ 152 mm	8	3/4 inch/ 19 mm	4.75 inch/ 120.6 mm	4.25 inch/ 108.0 mm
8 inch/ 203 mm	12	7/8 inch/ 22 mm	5.50 inch/ 139.7 mm	4.75 inch/ 120.6 mm

Flange gasket materials should conform to ANSI B16.20. The user should select a gasket material which will withstand the expected bolt loading without injurious crushing, and which is suitable for the service conditions.

NOTICE

To prevent damage to the valve seals due to the extremely hot purge temperature, do NOT insulate the valve or actuator. Insulation may be used on the inlet horizontal leg of the pipe. There should be no insulation around the outlet flange of the valve or the outlet riser pipe. If the outlet riser pipe is longer than 6 diameters, insulation may be used below the 6-diameter mark.

When installing the valve into the process piping, it is important to properly torque the stud/bolts in the appropriate sequence in order to keep the flanges of the mating hardware parallel to each other. A two-step torque method is recommended. Once the studs/bolts are hand tightened, torque the studs/bolts in a crossing pattern to half the torque value listed in the following table. Once all studs/bolts have been torqued to half the appropriate value, repeat the pattern until the rated torque value is obtained.

Table 3-2. Bolt Size and Torque Specifications

Bolt Size	Torque
5/8 inch/ 16 mm	150–155 lb-ft/ 203–210 N·m
3/4 inch/ 19 mm	250–260 lb-ft/ 339–353 N·m
7/8 inch/ 22 mm	375–390 lb-ft/ 508–529 N·m

Hydraulic Connections

Two hydraulic connections must be made to each valve: supply and return. The connections to the valve are straight-thread O-ring style ports per SAE J514. The tubing up to the valve must be constructed to eliminate any transfer of vibration or other forces into the valve.

Make provisions for proper filtration of the hydraulic fluid that will supply the actuator. The system filtration should be designed to assure a supply of hydraulic oil with a maximum ISO 4406 contamination level of 18/16/13 and a preferred level of 16/14/11. The filter element included with the actuator is not intended to provide adequate filtration over the entire life of the actuator.

The hydraulic supply to the actuator is to be 0.500 inch (12.70 mm) tubing capable of supplying 10 US gallons/min (18 L/min) at 1200–1700 psig (8274–11 722 kPa).

The hydraulic drain should be 1.00 inch (25.4 mm) tubing and must not restrict the flow of fluid from the valve. The drain pressure must not exceed 30 psig (207 kPa) under any condition.

Electrical Connections



WARNING

EXPLOSION HAZARD—Do not connect or disconnect while circuit is live unless area is known to be non-hazardous.

Substitution of components may impair suitability for Class I, Division 2 or Zone 2.



WARNING

Due to the hazardous location listings associated with this valve, proper wire type and wiring practices are critical to operation.

NOTICE

Do not connect any cable grounds to “instrument ground”, “control ground”, or any non-earth ground system.

The use of cable with individually-shielded twisted pairs is recommended. All signal lines should be shielded to prevent picking up stray signals from nearby equipment. Installations with severe electromagnetic interference (EMI) may require shielded cable run in conduit, double-shielded wire, or other precautions. Connect the shields at the control system side or as indicated by the control system wiring practices, but never at both ends of the shield such that a ground loop is created. Wires exposed beyond the shield must be less than 2 inches (51 mm). The wiring should provide signal attenuation to greater than 60 dB.

Servo Valve Electrical Connection

Servo valve cable should consist of three individually shielded twisted pairs. Each pair should be connected to one coil of the servo valve as indicated in Figure 1-5 (Wiring Diagram).

LVDT Electrical Connection

The LVDT cable must consist of individually shielded twisted pairs. A separate pair should be used for each of the excitation voltages to the LVDT, and a separate pair used for each of the feedback voltages from the LVDT.

Electric Trip Solenoid Connection

The electric trip solenoid valve must use wire suitable for at least 300 V.

Fuel Vent Port

There is a fuel vent port that must be vented to a safe location. In normal operation, this vent should have zero leakage. However, if excessive leakage is detected from this vent port, contact a Woodward representative for assistance.

Electronic Settings

Dynamic Tuning Parameters

It is imperative that the correct dynamic characteristics of this valve be input into the control system to ensure that the operation of the valve/control system is within acceptable limits.

Null Current Adjustment

Every valve shipped contains documentation that gives the actual Null Current as measured by Woodward. It is imperative that the control system null current match the as-measured current for each valve in the system. Incorrect null current setting, with proportional control only, will result in position error.

Rigging Procedure

Inside the electrical enclosure of the valve, there is an adhesive label that contains the appropriate valve position (as a percent of full stroke), the physical stroke (inches), and the corresponding LVDT feedback signals for each LVDT (assuming 7.0 Vrms excitation at 3000 Hz).

Once the control system is connected to the valve and control of the valve is established, set the valve command position to 10% of full stroke. Measure the feedback voltage from each LVDT. Adjust the Offset in the feedback loop until the feedback voltage matches the documented values (see the label inside the electrical enclosure) for that position. Adjust the command position to 90% of full stroke. Adjust the Gain of the feedback loop until the LVDT feedback voltage matches the documented values. Set the command position to close the valve. Verify that the valve is closed visually and that the feedback voltage from the LVDT is 0.7 ± 0.1 Vrms. This process may have to be repeated to ensure the feedback voltages at both the 10% and 90% command positions match the documented values.

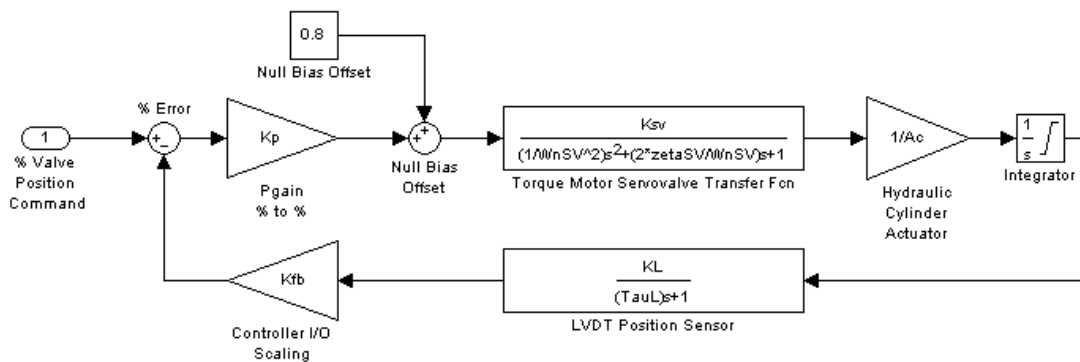

Figure 3-4. Gas Fuel Control Valve Block Diagram

	<u>2 & 3" valves</u>	<u>4 & 6" valves</u>
Ksv nominal =	6.1 in ³ /sec/mA at 1600 psi supply; Ksv is proportional to square root of supply, and constant with position.	2.8 in ³ /sec/mA
Ksv =	8.1 in ³ /sec/mA in the opening direction	3.74 in ³ /sec/mA in the opening direction
Ksv =	2.8 in ³ /sec/mA in the closing direction	2.13 in ³ /sec/mA in the closing direction
ZetaSV =	0.7	
WnSV =	502 rad/s (80 Hz); WnSV is proportional to square root of supply	
Ac =	6.98 in ²	6.55 in ²
KL =	1.38 Vrms/inch	
Servo Travel =	1.5 inches (1.14 inches for 3.0 inch, 1500 Cg valve)	
TauL =	0.005 seconds (depends on excitation/demodulation)	

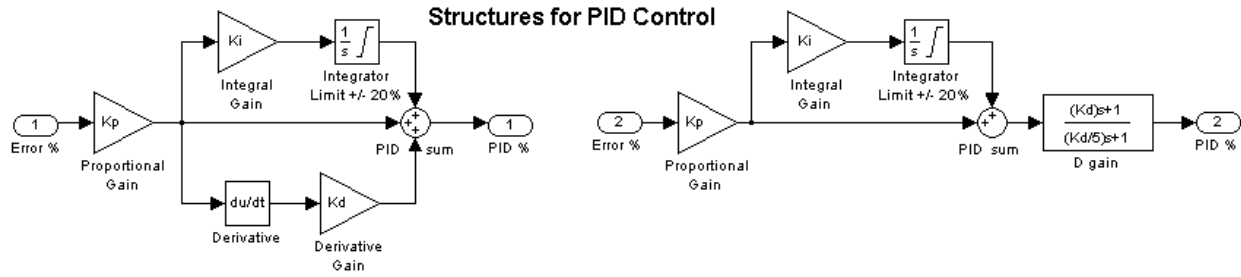

Figure 3-5. Structures for PID Control

Table 3-3. Recommended Control Gain Values for Different Control Types

Control Gain Settings	Proportional Control	Proportional Integral	Proportional Integral Derivative
	$K_p=5;$	$K_p=3; K_i=5;$	$K_p=3; K_i=5;$ $K_d=0.01$ or $\text{Tau Lead} = 0.01$

Chapter 4. Maintenance and Hardware Replacement

Maintenance

**WARNING**

Any cleaning by hand or with water spray must be performed while the area is known to be non-hazardous to prevent an electrostatic discharge in an explosive atmosphere.

The SonicFlo™ valve requires no maintenance or adjustment for operation.

Woodward recommends routine checks of the DP gauge on the filter assembly to verify that the filter is not partially clogged. If the DP indicator shows red, the filter element needs to be replaced.

In the event that any of the standard components of the valve become inoperative, field replacement is possible. Contact a Woodward representative for assistance.

Hardware Replacement

**WARNING**

EXPLOSION HAZARD—Do not connect or disconnect while circuit is live unless area is known to be non-hazardous.

Substitution of components may impair suitability for Class I, Division 2 or Zone 2 applications.

**WARNING**

To prevent possible serious personal injury, or damage to equipment, be sure all electric power, hydraulic pressure, and gas pressure have been removed from the valve and actuator before beginning any maintenance or repairs.

**WARNING**

Do not lift or handle the valve by any conduit. Lift or handle the valve only by using the eyebolts. Use a “Y” type lifting configuration to prevent damage to the LVDT conduit.

**WARNING**

Due to typical noise levels in turbine environments, hearing protection should be worn when working on or around the SonicFlo valve.

**WARNING**

The surface of this product can become hot enough or cold enough to be a hazard. Use protective gear for product handling in these circumstances. Temperature ratings are included in the specification section of this manual.

**WARNING**

External fire protection is not provided in the scope of this product. It is the responsibility of the user to satisfy any applicable requirements for their system.

To facilitate field replacement of items, spare parts should be kept on-site. See the outline drawing (Figures 1-2 through 1-9) for the locations of items. Contact Woodward for a complete list of field-replaceable parts and additional instructions for their replacement.

Hydraulic Filter Assembly/Cartridge

The hydraulic filter is located on the hydraulic manifold. It is hanging directly under the servo valve.

Replacement of Filter Assembly:

1. Remove the four 0.312-18 socket head cap screws.

IMPORTANT

The filter contains a large amount of hydraulic fluid that may be spilled during filter removal.

2. Verify that two O-rings are present in the interface between the filter and the manifold.
3. Obtain a new filter assembly from Woodward.
4. Verify that two new O-rings are present in the new filter assembly.
5. Install the filter assembly onto the manifold assembly. Be sure to place the filter in the correct orientation. See the outline drawing (Figures 1-2 through 1-9).
6. Install the four 0.312-18 cap screws through the filter and torque to 244–256 lb-in (27.6–28.9 N·m).
7. Check for external leakage upon pressurizing the hydraulic system.

Replacement of Filter Cartridge:

1. Using a 1-5/16 wrench, loosen the bowl from the filter assembly.

IMPORTANT

The filter contains a large amount of hydraulic fluid that may be spilled during filter removal.

2. Remove the filter element by pulling straight down from the rest of the assembly.
3. Obtain a new filter element from Woodward.
4. Lubricate the O-ring on the inside diameter of the cartridge with hydraulic fluid.
5. Install the cartridge into the assembly by sliding the open end of the cartridge onto the nipple.
6. Install the filter bowl onto the assembly. Tighten only by hand. Do not torque the bowl.
7. Check for external leakage upon pressurizing the hydraulic system.

Trip Relay Valve Cartridge (for valves with trip option)

The trip relay valve cartridge is located in the trip relay block on top of the hydraulic manifold block, next to the servo valve. See the outline drawings (Figures 1-2 through 1-9).

1. Using a 1-1/2 inch wrench (~38+ mm), loosen the trip relay valve from the trip relay block.
2. Slowly remove the cartridge from the trip relay block.

IMPORTANT

Hydraulic fluid may spill during cartridge removal.

3. Obtain a new trip relay valve cartridge from Woodward.
4. Verify that all O-rings are present on the new cartridge.
5. Lubricate the O-rings with hydraulic fluid or petroleum jelly.
6. Install the cartridge into the trip relay block.
7. Torque to 80–90 lb-ft (108–122 N·m).
8. Check for external leakage upon pressurizing the hydraulic system.

Servo Valve

The servo valve is located on the hydraulic manifold directly above the filter assembly. See the outline drawing (Figures 1-2 through 1-9).

IMPORTANT

There could be a substantial amount of hydraulic fluid upon removal.

IMPORTANT

The 2 inch valves contain an intermediate orifice plate.

1. Remove the cover to the electrical junction box.
2. Disconnect the servo valve wires from the connector blocks labeled 1-6.
3. Loosen the conduit fittings from the electrical box and the servo valve.
4. Carefully remove the conduit from the servo valve and pull the wiring out of the conduit.
5. Remove the four 0.312-18 UNF socket head cap screws holding the servo valve to the manifold.
6. Verify that all four O-rings are removed from the interface between the manifold and the servo valve. On units with an intermediate orifice plate, verify that the four O-rings between the servo valve and plate are removed.
7. Obtain a replacement servo valve from Woodward and verify part number and revision with the existing unit.
8. Remove the protective plate from the replacement servo valve and verify that O-rings are on all four counter bores of the servo valve.
9. Place the replacement servo valve onto the hydraulic manifold. Be sure to orient the servo valve to match the original orientation. Be sure that all four O-rings remain in their proper location during assembly. On units with an intermediate orifice plate, verify that the three O-rings on the underside of the orifice plate are in their grooves. Verify that the plate is in the proper location by aligning the "P" and "T" on the side of the servo valve with the "P" and "T" etched into the plate. Be sure to orient the servo valve/orifice plate to match the original orientation. Be sure that all seven O-rings remain in their proper location during assembly.
10. Install four 0.312-18 UNF socket head cap screws and torque to 55–57 lb-in (6.2–6.4 N·m).
11. Install wiring through the conduit and into the electrical box.
12. Connect the conduit to the servo valve and torque to 270–300 lb-in (31–34 N·m).
13. Torque the conduit to the electrical box to 270–300 lb-in (31–34 N·m).
14. Install wires into the servo valve connector blocks labeled 1-6 as shown in the wiring diagram (Figure 1-11). If it is necessary to cut wires for installation, be sure to retain at least one service loop of wiring.
15. Replace the cover onto the junction box and tighten the screws.
16. Check for external leakage upon pressurizing the hydraulic system.

LVDT (For 2" Valves)

The LVDT is located on the top of the actuator. See the outline drawing (Figures 1-2 & 1-3).

1. Remove the cover to the electrical junction box.
2. Disconnect the LVDT wires from the connector blocks.
3. Loosen the conduit fittings from the electrical box and the LVDT.
4. Carefully remove the conduit from the LVDT and pull the wiring out of the conduit.
5. Remove the conduit from the electrical box.
6. Remove the protective covers from the four threaded tie rods that hold the actuator together. Remove the two "eye nuts" from the two-tie rods.
7. Remove the four 0.500-13 jam nuts from the tie rods.
8. Remove the two 0.250-20 socket head cap screws that hold the electrical box to the top mounting plate. The cap screws have nuts and washers.

**WARNING**

To prevent possible personal injury, do NOT completely remove the nuts in step 9 from the tie rods until you have verified that the preload has been removed from the springs.

9. Slowly remove the four remaining 0.500-13 nuts from the tie rods, rotating each nut one turn at a time. This will keep the cover and LVDT square with the housing. Failure to remove the nuts in this manner can cause the cover and LVDT body to become misaligned with the LVDT core rods, potentially damaging them.
This action will release the preload on the integral springs of the actuator. The tie rod studs should be long enough to completely release the preload prior to coming off of the tie rods. Do NOT completely remove the nuts from the tie rods until you have verified that the preload has been removed from the springs; failure to comply could result in bodily injury.
10. The top plate should be free to be removed from the assembly. The LVDT will be removed with the top plate.
11. Remove the springs from the actuator.
12. Using a 0.750 crowfoot wrench and an extension, remove the core rod of the LVDT from the actuator piston. Be sure not to mix the old LVDT core rod and body with the replacement parts.
13. Using a 1-1/4 inch (~32– mm) wrench, remove the two 1.125-12 jam nuts from the LVDT housing.
14. Remove the LVDT from the top plate.
15. Install the new LVDT housing into the top plate and replace the two jam nuts. Do not tighten the jam nuts yet; the LVDT will need to be adjusted prior to use.
16. Install the new core rod into actuator piston using the 0.750 crowfoot wrench and an extension. Torque to 70–73 lb-in (7.9–8.2 N·m).
17. On dual-coil, dual-rod LVDT units, notice on the base of the core rods that one of them is labeled with a “I”. Note its orientation for future reference.
18. Install the springs back into the actuator. Be sure that they are seated in the proper location.
19. Carefully replace the top plate and LVDT housing onto the actuator. On dual-coil, dual-rod LVDT units, one of the core rod openings in the LVDT housing is labeled with a “I”. Be sure that the core rod labeled with the “I” is placed in the corresponding hole.
20. Replace the electrical enclosure bracket onto the two appropriate studs.
21. Install four 0.500-13 nuts, one onto each stud. Slowly compress the springs into their cavity by rotating each nut one turn at a time. This will keep the cover and LVDT square with the housing. Failure to install the nuts in this manner can cause the cover and LVDT body to become misaligned with the LVDT core rod(s), potentially damaging them.
22. Torque the 0.500 nuts to 35–42 lb-ft (47–57 N·m).
23. Install four additional 0.500-13 nuts onto the studs and torque to 18–21 lb-ft (24–28 N·m).
24. Install the two 0.250-20 socket head cap screws that hold the electrical box to the top mounting plate. The cap screws have nuts and washers.
25. Torque the two cap screws to 58–78 lb-in (6.6–8.8 N·m).
26. Replace the protective covers onto the tie rods.
27. Replace the two “eye nuts” from the two-tie rods.
28. Replace the conduit onto the electrical box.
29. Carefully replace the LVDT wires back through the conduit and into the electrical box.
30. Connect the conduit to the LVDT. Do not tighten.
31. Connect the LVDT wires to the connector blocks as shown in the appropriate wiring diagram (Figure 1-11).
32. Replace the cover to the electrical box.
33. Verify that all hardware has been replaced onto the actuator and that all external fittings are torqued except for the lock nuts on the LVDT and the conduit on the LVDT.
34. Verify that the excitation voltage to each LVDT is 7.00 ±0.10 Vrms (measured across terminals 7 & 8 and 11 & 12 [also 15 & 16 if triple coil LVDT]).
35. Supply the actuator with hydraulics at 1200–1700 psig (8274–11 722 kPa).
36. Measure the LVDT output voltage using a high-quality digital voltmeter (select AC measurement mode).

37. With the actuator at minimum position, the output of the LVDT (measured across terminals 9 & 10 and 13 & 14 [and 17 & 18 if triple coil LVDT]) should be 0.700 ± 0.100 Vrms. If the readout is not within these specifications, adjust the LVDT in or out of the actuator by screwing the LVDT housing in or out of the top block. **NOTE—A small rotation of the LVDT will cause a substantial change in the readout.**
38. Once 0.700 Vrms is obtained, carefully torque the bottom nut to 50–75 lb-ft (68–102 N·m). Then torque the remaining nut to 25–37.5 lb-ft (34–50.8 N·m).
39. Torque the conduit onto the LVDT to 450–550 lb-in (51–62 N·m).
40. Adjust the control system to command the valve to 100% open.
41. The readout of the LVDT should now be 3.50 ± 0.50 Vrms.
42. If the readout at 100% is not within tolerance, repeat steps 36–40.

LVDT (for 3", 4", and 6" valves)

IMPORTANT

If the valve is characterized, the LVDT cannot be replaced in the field. The valve must be returned for factory calibration and testing.

The LVDT is located on the top of the actuator. See the outline drawing (Figures 1-2 through 1-9).

1. Remove the cover to the electrical junction box.
2. Disconnect the servo valve wires from the connector blocks labeled 1-6, the LVDT wires from the connector block labeled 7-18, and the grounding wire.
3. Loosen the conduit fittings from the LVDT, the servo valve, and the electrical box.
4. Carefully remove the conduit from the LVDT and servo valve, and pull the wiring out of the conduit.
5. Remove the conduit from the electrical box.
6. Remove the four 0.625-11 jam nuts from the bottom end of the tie rods (on the underside of the hydraulic manifold). Next, remove the four remaining 0.625-11 nuts.
7. Carefully remove the entire actuator sub-assembly from the valve.
8. Remove the four 0.625-11 jam nuts from the tie rods just below the bottom cylinder plate.

WARNING

To prevent possible personal injury, do NOT completely remove the nuts in step 9 from the tie rods until you have verified that the preload has been removed from the springs.

9. Slowly remove the four remaining 0.625-11 nuts from the bottom end of the tie rods, rotating each nut one turn at a time. This will keep the cover and LVDT square with the housing. Failure to remove the nuts in this manner can cause the cover and LVDT body to become misaligned with the LVDT core rods, potentially damaging them. This action will release the preload on the integral springs of the actuator. The tie rod studs are long enough to completely release the preload prior to coming off of the tie rods. Do NOT completely remove the nuts from the tie rods until you have verified that the preload has been removed from the springs; failure to comply could result in bodily injury.
10. The bottom plate and the spring seat should be free to be removed from the assembly. The LVDT core rods will be removed with the spring seat.
11. Using a 0.750 wrench, remove the core rod of the LVDT from the spring seat. Be sure not to mix the old LVDT core rod and body with the replacement parts.
12. Bend the tab down on the locking washer and loosen the 1.25-12 jam nut on the LVDT housing.
13. Remove the LVDT from the top plate.
14. Install the new core rod into the spring seat using the 0.750 wrench. Torque to 70–73 lb-in (7.9–8.2 N·m).
15. Notice on the base of the core rods that one of them is labeled with a "1". Note its orientation for future reference.
16. Make sure that the springs are seated in the proper location.
17. Carefully install the spring seat and core rod sub-assembly onto the springs, with the core rods inserted into the center of the springs. Next, install the bottom cylinder plate and guide pin sub-assembly onto the tie rods with the guide pin towards the spring seat. Align the spring seat such that the guide pin is inserted into the corresponding spring seat hole.

18. Install four 0.625-11 nuts, one onto each stud. Slowly compress the springs into their cavity by rotating each nut one turn at a time. This will keep the cover and core rods square with the housing. Failure to install the nuts in this manner can possibly cause damage to the LVDT core rods.
19. Torque the 0.625 nuts to 150–188 lb-ft (203–255 N·m).
20. Install four additional 0.625 nuts onto the studs, and torque to 75–94 lb-ft (102–127 N·m).
21. Using a flashlight, confirm the location/orientation of the core rod labeled with a “1”. Making sure that the locking tab washer is in place, carefully install the new LVDT housing through the washer and into the top plate, oriented such that the core rod opening labeled with a “1” is aligned with the corresponding core rod. Once the LVDT housing is assembled onto the core rods, partially thread the LVDT housing into the top plate. Do not tighten the jam nut yet, as the LVDT will need to be adjusted prior to use.
22. Replace the conduit onto the electrical box.
23. Carefully replace the LVDT wires and servo valve wires through the conduits and into the electrical box.
24. Connect the conduit to the LVDT and servo valve. Do not tighten.
25. Connect the servo valve wires to the connector blocks labeled 1-6, the LVDT wires to the connector blocks labeled 7-18, and the ground wire to the ground screw as shown in the wiring diagram (Figure 1-11).
26. Replace the cover to the electrical box.
27. Verify that all hardware has been replaced onto the actuator and that all external fittings are torqued except for the lock nuts on the LVDT and the conduit on the LVDT.
28. Replace the actuator onto the valve, guiding the 4 tie rods through the mounting holes in the manifold. Make sure the electrical junction box is oriented on the same side as the servo valve.
29. Install four 0.625-11 nuts, one onto each stud. Torque the nuts to 150–188 lb-ft (203–255 N·m).
30. Install four additional 0.625 nuts onto the studs, and torque to 75–94 lb-ft (102–127 N·m).
31. Verify that the excitation voltage to each LVDT is 7.00 ± 0.10 Vrms (measured across terminals 7 & 8 and 11 & 12 and 15 & 16).
32. Supply the actuator with hydraulics at 1300–1800 psig (8964–12411 kPa).
33. Measure the LVDT output voltage using a high-quality digital voltmeter (select AC measurement mode).
34. With the actuator at minimum position, the output of the LVDT (measured across terminals 9 & 10 and 13 & 14 and 17 & 18) should be 0.700 ± 0.100 Vrms. If the readout is not within these specifications, adjust the LVDT in or out of the actuator by screwing the LVDT housing in or out of the top block. **NOTE—A small rotation of the LVDT will cause a substantial change in the readout.**
35. Once 0.700 Vrms is obtained, carefully torque the LVDT jam nut to 50–75 lb-ft (68–102 N·m). Then bend the tab on the locking washer up to prevent loosening of the jam nut.
36. Torque the LVDT conduit onto the LVDT and electrical box to 450–550 lb-in (51–62 N·m). Torque the servo valve conduit onto the servo valve and electrical box to 270–300 lb-in (31–34 N·m).
37. Adjust the control system to command the valve to 100% open.
38. The readout of the LVDT should now be 3.50 ± 0.50 Vrms.
39. If the readout at 100% is not within tolerance, repeat steps 36–40.

Clacking (Rotation) of Actuator to Valve (for 2” valves)



Be sure all electric power, hydraulic pressure, and gas pressure have been removed from the valve and actuator before maintenance or repairs begin.

See the outline drawing (Figures 1-2 & 1-3) for the location of items.

Rotation of Actuator Cylinder to Modify the Position of the Visual Indicator

1. Remove the protective covers from the four threaded tie rods that hold the actuator together.
2. Remove the two “eye nuts” from the two tie rods.
3. Remove the two fitting nuts holding the hydraulic overboard vent tube; remove the vent tube.
4. Remove the top 0.500-13 jam nuts from each of the four tie rods.
5. Remove the two 0.250-20 socket head cap screws that hold the electrical box to the top mounting plate. The cap screws have nuts and washers.

**WARNING**

To prevent possible personal injury, do NOT completely remove the nuts in step 6 from the tie rods until you have verified that the preload has been removed from the springs.

6. Slowly remove the four remaining 0.500-13 nuts from the tie rods, rotating each nut one turn at a time. This will keep the cover and LVDT square with the housing. Failure to remove the nuts in this manner can cause the cover and LVDT body to become misaligned with the LVDT core rod(s), potentially damaging them.
This action will release the preload on the integral springs of the actuator. The tie rod studs should be long enough to completely release the preload prior to coming off of the tie rods. Do NOT completely remove the nuts from the tie rods until you have verified that the preload has been removed from the springs; failure to comply could result in bodily injury.
7. Using a strap wrench or by hand, rotate the actuator cylinder to the required position.
8. Install four 0.500-13 nuts, one onto each stud. Slowly compress the springs into their cavity by rotating each nut one turn at a time. This will keep the cover and LVDT square with the housing. Failure to install the nuts in this manner can cause the cover and LVDT body to become misaligned with the LVDT core rods, potentially damaging them.
9. Torque the 0.500 nuts to 35–42 lb-ft (47–57 N·m).
10. Install four additional 0.500-13 nuts onto the studs and torque to 18–21 lb-ft (24–28 N·m).
11. Install the two 0.250-20 socket head cap screws that hold the electrical box to the top mounting plate. The cap screws have nuts and washers.
12. Torque the two cap screws to 58–78 lb-in (6.6-8.8 N·m).
13. Because the cylinder has been rotated, a new hydraulic overboard vent tube will have to be fabricated to reconnect the overboard vent to the hydraulic manifold. Torque the fittings on the overboard vent line to 134–150 lb-in (15–17 N·m).
14. Replace the two “eye nuts” on the two tie rods.
15. Replace the protective covers onto the tie rods.

Rotation of Actuator Relative to the Gas Valve

1. If the valve is contained within the piping, confirm there is no pressure in the valve and that the isolation valves have been appropriately locked out. Carefully support the valve using the two lifting lugs located on the top of the valve/actuator.
2. Remove four 0.500-13 cap screws from the actuator base. Once the screws are removed, there are four one-inch (25 mm) long spacers that fit between the actuator and the valve housings. Be sure to collect and save these for installation.
3. Rotate the actuator to one of three quadrants; the actuator may only be rotated 90 degrees either way from the as-shipped configuration. Do not remove the actuator from the valve body, simply rotate the actuator while still in the valve body. Be sure that the filter assembly and other components are not being damaged during rotation and in service.
4. Replace the four spacers (one on each cap screw) and the four 0.500-13 cap screws into the actuator, and thread into the valve body.
5. Torque the 0.500 cap screws to 700–875 lb-in (79–99 N·m).
6. Verify that the spacers are all tightly held between the actuator and valve bodies.

Clocking (Rotation) of Actuator to Valve (for 3”, 4”, and 6” valves)

**WARNING**

Be sure all electric power, hydraulic pressure, and gas pressure have been removed from the valve and actuator before maintenance or repairs begin.

See the outline drawing (Figures 1-2 through 1-9) for the location of items.

Rotation of Actuator Relative to the Gas Valve

1. If the valve is contained within the piping, confirm there is no pressure in the valve and that the isolation valves have been appropriately locked out. Carefully support the valve using the two lifting lugs located on the top of the valve/actuator while the valve is supported from below.

2. Remove four 0.625-11 cap screws and washers from the top of the hydraulic manifold. Once the screws are removed, there are four 1-1/2-inch (38 mm) long spacers that fit between the actuator and the valve housings. Be sure to collect and save these for installation.
3. Do not remove the actuator from the valve body, simply rotate the actuator while still in the valve body and while supporting the weight of the actuator from above. The actuator may only be rotated 90 degrees either way from the as-shipped configuration.
4. Replace the four spacers (one on each cap screw) and the four 0.625-11 cap screws and washers into the actuator, and thread into the valve body.
5. Torque the 0.625-11 cap screws to 116.0–132.5 lb-ft (157.3–179.7 N·m).
6. Verify that the spacers are all tightly held between the actuator and valve bodies.

Inspections

Woodward recommends the following maintenance and inspection schedule for the SonicFlo valve:

Routine Inspections

Routinely check the DP gauge on the filter assembly to verify that the filter is not partially clogged. If the DP indicator shows red, the filter element needs to be replaced.

Annual Inspections

- Pressurize the valve section of the assembly to the rated pressure of 580 psig (4000 kPa) for class 600 valves or 450 psig (3100 kPa) for class 300 valves. Inspect external sealing surfaces for leakage using leak detect fluid. These locations include the inlet and discharge flange connections as well as the pilot sleeve/valve body interface. No leakage is permitted from these areas.
- Pressurize the valve section of the assembly to 50 psig (340 kPa) and inspect for excessive overboard vent leakage from the Fuel Drain Port on the valve. The leakage should be less than 100 cm³/minute.

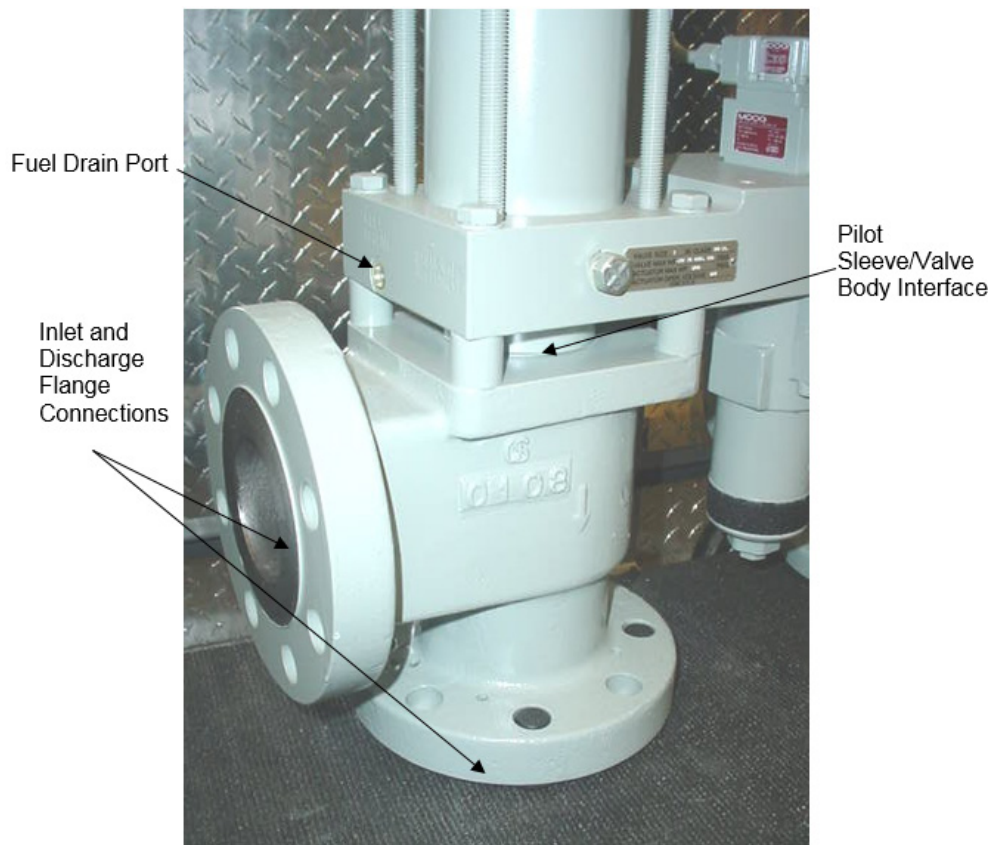

Figure 4-1a. Inspection Areas for 2 Inch Valves

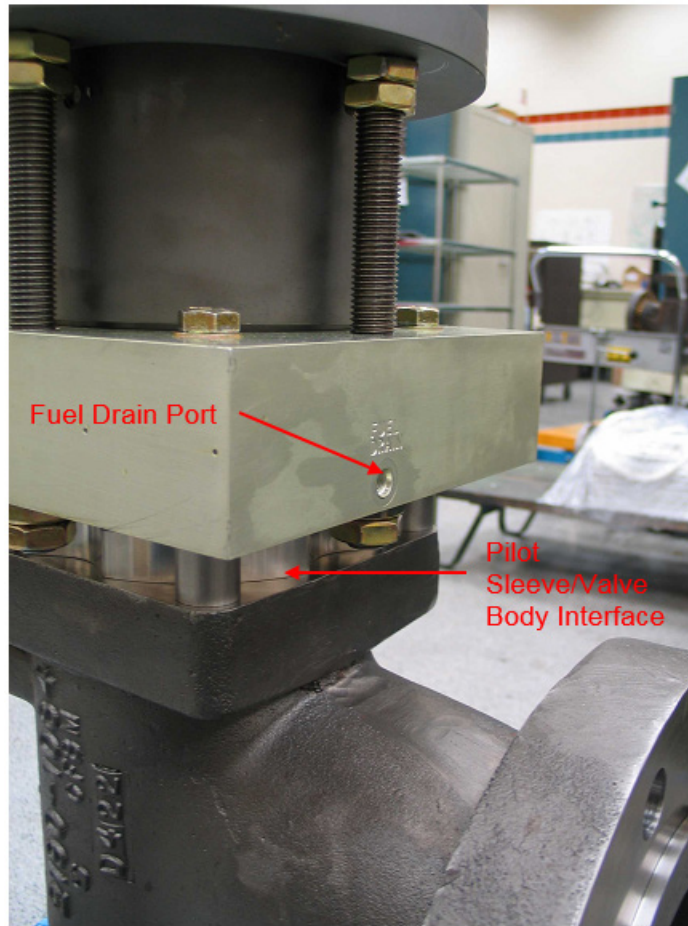

Figure 4-1b. Inspection Areas for 3, 4, and 6 Inch Valves

- 2 Inch Valves Only: Remove the hydraulic interseal drain tube and cap the drain fitting.



Figure 4-2. Location of Hydraulic Interseal Drain and Cap for 2 Inch Valves

- Pressurize the actuator section of the assembly to the rated pressure of 1700 psig (11 725 kPa) and perform the following inspections:
 - o Inspect all hydraulic sealing surfaces for external leakage.
 - o 2 Inch Valves Only: Monitor the leakage from the hydraulic interseal fitting (400 cm³/min maximum).
 - o Remove hydraulic pressure.
 - o 2 Inch Valves Only: Remove cap, and re-install interseal vent tube.

Overhaul / Replace Valve

- If there is any external leakage, or if either the gas leakage from the fuel drain port or the hydraulic leakage from the interseal fitting exceeds the limits stated above, the valve should be removed and returned to Woodward for overhaul.
- Otherwise, Woodward recommends valves be removed from service and returned to Woodward for overhaul every 48 000 hours of operation or at the nearest major turbine overhaul, whichever comes first.

In the event that any of the standard components of the valve become inoperative, field replacement is possible. Contact a Woodward representative for assistance.

Troubleshooting

Gas Fuel Control Valve not functioning correctly when using customer control system.

Perform steps 34 through 38 for the 2 inch valves, or steps 31 through 35 for the 3, 4, and 6 inch valves, of the LVDT replacement procedure above. The troubleshooting tool (Woodward part number 1010-4982) can be installed in place of the visual indicator to assist in mechanically determining valve stroke (verify that the valve is at the minimum position).

1. Remove two socket head cap screws holding the visual indicator onto the control valve actuator. Save screws for replacement of visual indicator.
2. Remove the visual indicator.
3. Using two cap screws provided, attach tool 1010-4982 (available from Woodward) to the actuator. Be sure to place the pin of the sliding piece onto the top of the spring seat within the actuator housing.
4. Using a customer-supplied travel indicator with a total stroke greater than 3.10 inches (78.7 mm) placed on top of the sliding piece of the tool, attach the indicator to the actuator housing. Zero the indicator.
5. Raise the servo valve current to 2 ± 0.5 mA. The valve should move fully open.
6. The maximum travel should match the value recorded within the electrical enclosure. If this value is not the same, contact Woodward for recommendations.
7. If this value matches the recorded value, check the feedback voltage of the LVDT (all three coils) vs the recorded values in the electrical enclosure.
8. If the feedback voltages do not match, verify that the excitation voltage is 7.00 ± 0.100 Vdc at 3000 Hz. If the excitation voltage is correct, and the LVDT output voltage does not match the values listed on the calibration sticker, contact Woodward for a replacement LVDT and follow the steps listed within this document for replacement.
9. If the feedback and physical stroke values match the recorded values supplied with the valve, then the control system is not functioning properly. Refer to the control system manufacturer for troubleshooting assistance.

Troubleshooting Charts

Faults in the fuel control or governing system are often associated with speed variations of the prime mover, but such speed variations do not always indicate fuel control or governing system faults. Therefore, when improper speed variations occur, check all components including the engine or turbine for proper operation. Refer to applicable electronic control manuals for assistance in isolating the trouble. The following steps describe troubleshooting for the gas fuel control valve.

Disassembly of the gas fuel control valve in the field is not recommended due to the dangerous forces contained in the springs. Under unusual circumstances where disassembly becomes necessary, all work and adjustments should be made by personnel thoroughly trained in the proper procedures.

When requesting information or service help from Woodward, it is important to include the part number and serial number of the valve assembly in your communication.

Table 4-1. Troubleshooting Symptoms, Possible Causes, and Remedies

Symptom	Possible Causes	Remedies
External hydraulic leakage	Static O-ring seal(s) missing or deteriorated	Replace O-rings fitted to user-serviceable components (filter, servo valve, trip relay valve) as needed. Otherwise, return actuator to Woodward for service.
	Dynamic O-ring seal missing or deteriorated	Return actuator to Woodward for service.
Internal hydraulic leakage	Servo valve internal O-ring seal(s) missing or deteriorated	Replace servo valve.
	Servo valve metering edges worn	Replace servo valve.
	Piston seal missing or deteriorated	Return actuator to Woodward for service.
External gas fuel leakage	Piping flange gaskets missing or deteriorated	Replace gaskets.
	Piping flanges improperly aligned	Rework piping as needed to achieve alignment requirements detailed in Chapter 3.
	Piping flange bolts improperly torqued	Rework bolts as needed to achieve torque requirements detailed in Chapter 3.
	Packing missing or deteriorated	Return actuator to Woodward for service.
Valve will not open	Servo valve command current incorrect. (The sum of the current through the three coils of the servo valve must be greater than the null bias of the servo valve for the gas valve to open.)	Trace and verify that all wiring is in accordance with the electrical schematic (Figures 1-11 & 1-12) and the system wiring schematic(s). Pay special attention to the polarity of the wiring to the servo valve and LVDT.
	Servo valve failure	Replace servo valve.
	Hydraulic supply pressure inadequate	Supply pressure must be greater than 1200 psig/8274 kPa (1600 psig/11 032 kPa preferred).
	Trip relay pressure inadequate (if applicable)	Trip pressure must be greater than 40 psig (276 kPa). On the high pressure trip option, the trip pressure must be greater than 900 psig (6205 kPa).
	Filter element plugged	Check filter DP indicator. Replace element if the DP indicator shows red.

Symptom	Possible Causes	Remedies
Valve will not close	Servo valve command current incorrect. (The sum of the current through the three coils of the servo valve must be less than the null bias of the servo valve for the gas valve to close.)	Trace and verify that all wiring is in accordance with the electrical schematic (Figures 1-11 & 1-12) and the system wiring schematic(s). Pay special attention to the polarity of the wiring to the servo valve and LVDT.
	Servo valve failure	Replace servo valve.
	LVDT failure	Replace LVDT. If characterized, return to Woodward for service.
	Springs broken	Return actuator to Woodward for service.
	Linkage broken	Return actuator to Woodward for service.
Valve will not respond smoothly	Hydraulic filter clogged	Check the differential pressure indicator on the filter housing.
	Servo valve spool sticking	Verify hydraulic contamination levels are within recommendations of Chapter 1. The use of dither may improve performance in contaminated systems.
	Servo valve internal pilot filter clogged	Replace servo valve.
	Piston seal worn out	Return actuator to Woodward for service.
	Control system instability	Contact control system supplier.
Actuator seals wear out prematurely	Hydraulic contamination level is excessive	Verify hydraulic contamination levels are within recommendations of Chapter 1. The use of excessive dither may reduce life in contaminated systems.
	System is oscillating (seal life is proportional to distance traveled). Even small oscillations (on the order of $\pm 1\%$) at slow frequencies (on the order of 0.1 Hz) cause wear to accumulate rapidly.	Determine and eliminate the root cause of oscillation. Possible causes include inlet pressure regulation, control system setup, and improper wiring practices. See Chapter 3 Installation section for wiring recommendations.

Chapter 5.

Safety Management – Safe Position Fuel Shutoff Function

Safety Function

The SonicFlo™ Gas Fuel Control Valve will move to the closed position within the full stroke trip time listed in this manual.

Product Variations Certified

The SIL (Safety Integrity Level) rated SonicFlo™ Gas Fuel Control Valves for fuel shutoff are designed and certified to the functional safety standards according to IEC 61508, Parts 1 through 7. Reference the exida FMEDA report: WOO 17-04-071 R001, and Certification: WOO 17-04-071 C001. The exida FMEDA report is available on a per request basis from Woodward.

The functional safety requirements in this chapter apply to all SonicFlo™ Gas Fuel Control Valve configurations listed in Table 5-1.

The SonicFlo™ Gas Fuel Control Valve configurations listed in Table 5-1 are certified for use in applications up to SIL 3 according to IEC 61508. The SIL of an entire SIF (Safety Instrumented Function) must be verified via calculation of Average PFD (Probability of Failure on Demand) considering redundant architectures, proof test interval, proof test effectiveness, any automatic diagnostics, average repair and the specific failure rates of all products included in the SIF. Each element must be checked to assure compliance with the minimum HFT (Hardware Fault Tolerance) requirements.

The SonicFlo™ Gas Fuel Control Valves are classified as a device that is part Type A element according to IEC 61508, having a HFT of 0.

The SonicFlo™ Gas Fuel Control Valves are designed and verified to withstand the worst-case (or greater) expected environmental conditions as listed in other sections of this manual.

SFF (Safe Failure Fraction) for the SonicFlo™ Gas Fuel Control Valve – Over Speed SIF

The SonicFlo™ Gas Fuel Control Valve is only one part of a shutoff system that supports an over-speed shutdown SIF. This system consists of a speed sensor, a processing unit and a fuel shutoff actuation subsystem of which the SonicFlo™ Gas Fuel Control Valve is a component.

The SFF (Safe Failure Fraction) for each subsystem should be calculated. The SFF summarizes the fraction of failures which lead to a safe state plus the fraction of failures which will be detected by diagnostic measures and lead to a defined safety action. This is reflected in the following formulas for SFF:

$$SFF = \lambda_{SD} + \lambda_{SU} + \lambda_{DD} / \lambda_{TOTAL}$$

$$\text{Where } \lambda_{TOTAL} = \lambda_{SD} + \lambda_{SU} + \lambda_{DD} + \lambda_{DU}$$

The failure rates listed below, for only the SonicFlo™ Gas Fuel Control Valve, do not include failures due to wear-out of any components and are only valid for the useful lifetime of the SonicFlo™ Gas Fuel Control Valve. They reflect random failures and include failures due to external events such as unexpected use. Reference the exida FMEDA report: WOO 17-04-071 R001 for detailed information concerning the SFF and PFD.

Table 5-1. Failure Rates according to IEC 61508 in FIT

Failure Rates for Static Applications^[1] with Good Maintenance Assumptions in FIT @ SSI=2

Application/Device/Configuration	λ_{SD}	$\lambda_{SU}^{[2]}$	λ_{DD}	λ_{DU}	#	E
Full Stroke, Clean Service, Hydraulic Trip	0	76	0	828	1879	477
Full Stroke, Clean Service, Electric Trip	0	454	0	948	2092	487
Full Stroke, Clean Service, Dual Trip - Hydraulic	0	116	0	1047	2474	577
Full Stroke, Clean Service, Dual Trip - Electric	0	454	0	948	2092	487
Full Stroke, Clean Service, Hydraulic Trip, with PVST	76	0	419	409	1879	477
Full Stroke, Clean Service, Electric Trip, with PVST	450	4	516	432	2092	487
Full Stroke, Clean Service, Dual Trip – Hydraulic, with PVST	116	0	616	431	2474	577
Full Stroke, Clean Service, Dual Trip – Electric, with PVST	450	4	516	432	2092	487

According to IEC 61508 the architectural constraints of an element must be determined. This can be done by following the 1H approach according to 7.4.4.2 of IEC 61508 or the 2H approach according to 7.4.4.3 of IEC 61508. Reference the exida FMEDA report: WOO 17-04-071 R001 for additional information, including the assumptions used for the calculated FIT (Failure in Time) values in Table 5-1.

To claim diagnostic coverage for Partial Valve Stroke Testing (PVST), the PVST must be automatically performed at a rate at least ten times faster than the demand frequency with inclusions of position detection from the actuator's LVDT(s). Additionally, the PVST of the safety instrumented function must provide a full cycle test of the solenoid and/or hydraulic pilot valve depending on the device configuration. In cases where this is not true, another method must be used to perform a full solenoid/pilot valve cycle during automated diagnostics in order to use the PVST numbers.

Response Time Data

The SonicFlo™ Gas Fuel Control Valve full stroke trip time is as listed in this manual.

Limitations

When proper installation, maintenance, proof testing, and environmental limitations are observed, the design life of the SonicFlo™ Gas Fuel Control Valve is 250,000 hours of operation. Under “normal” operating conditions SonicFlo™ Gas Fuel Control Valves should be serviced with a factory or authorized service center overhaul every 50,000 hours not to exceed 6 years in service. Refer to service bulletin 01614 for additional service guidelines.

Management of Functional Safety

The SonicFlo™ Gas Fuel Control Valve is intended for use according to the requirements of a safety lifecycle management process such as IEC 61508 or IEC 61511. The safety performance numbers in this chapter can be used for the evaluation of the overall safety lifecycle.

^[1] Static Application failure rates are applicable if the device is static for a period of more than 200 hours.

^[2] It is important to realize that the No Effect failures are no longer included in the Safe Undetected failure category according to IEC 61508, ed2, 2010.

Restrictions

The user must complete a full functional check of the SonicFlo™ Gas Fuel Control Valve after initial installation, and after any modification of the overall safety system. No modification shall be made to the SonicFlo™ Gas Fuel Control Valve unless directed by Woodward. This functional check should include as much of the safety system as possible, such as sensors, transmitters, actuators, and trip blocks. The results of any functional check shall be recorded for future review.

Competence of Personnel

All personnel involved in the installation and maintenance of the SonicFlo™ Gas Fuel Control Valve must have appropriate training. Training and guidance materials are included in this manual.

These personnel shall report back to Woodward any failures detected during operation that may impact functional safety.

Operation and Maintenance Practice

A periodic proof (functional) test of the SonicFlo™ Gas Fuel Control Valve is required to verify that any dangerous faults not detected by safety controller internal run-time diagnostics are detected. More information is in the “Proof Test” section below. The frequency of the proof test is determined by the overall safety system design, of which the SonicFlo™ Gas Fuel Control Valve is part of the safety system. The safety numbers are given in the following sections to help the system integrator determine the appropriate test interval.

No special tools are required for operation or maintenance of the SonicFlo™ Gas Fuel Control Valve.

Installation and Site Acceptance Testing

Installation and use of the SonicFlo™ Gas Fuel Control Valve must conform to the guidelines and restrictions included in this manual.

Functional Testing after Initial Installation

A functional test of the SonicFlo™ Gas Fuel Control Valve is required prior to use in a safety system. This should be done as part of the overall safety system installation check and should include all I/O interfaces to and from the SonicFlo™ Gas Fuel Control Valve. For guidance on the functional test, see the Proof Test procedure below.

Functional Testing after Changes

A functional test of the SonicFlo™ Gas Fuel Control Valve is required after making any changes that affect the safety system. Although there are functions in the SonicFlo™ Gas Fuel Control Valve that are not directly safety related, it is recommended that a functional test be performed after any change.

Proof Test (Functional Test)

The SonicFlo™ Gas Fuel Control Valve must be periodically proof tested to ensure there are no dangerous faults present that are not detected by on-line diagnostics. This proof test should be performed at least once per year.

Suggested Proof Test

The suggested proof test consists of a full stroke of the valve, shown in the table below.

Table 5-2. Suggested Proof Test

Step	Action
1.	Bypass the safety function and take appropriate action to avoid a false trip.
2.	Issue a trip command to the SonicFlo™ Gas Fuel Control Valve to force the actuator/valve assembly to the Fail-Safe state and confirm that the Safe State was achieved and within the correct time.
	Note: This tests for all failures that could prevent the functioning of the control valve as well as the rest of the final control element.
3.	Inspect the actuator and valve for any leaks, visible damage or contamination.
4.	Re-store the original supply/input to the actuator and confirm that the normal operating state was achieved.
5.	Remove the bypass and otherwise restore normal operation.

For the test to be effective the movement of the valve must be confirmed. To confirm the effectiveness of the test both the travel of the valve and slew rate must be monitored and compared to expected results to validate the testing.

Proof Test Coverage

The Proof Test Coverage for the SonicFlo™ Gas Fuel Control Valve is given in the table below.

Table 5-3. Proof Test Coverage

Device	λ_{DUPT} (FIT)	Proof Test Coverage	
		No PVST	with PVST
Full Stroke, Clean Service, Hydraulic Trip	278	66.4%	32.0%
Full Stroke, Clean Service, Electric Trip	283	70.1%	34.5%
Full Stroke, Clean Service, Dual Trip - Hydraulic	280	73.3%	35.0%
Full Stroke, Clean Service, Dual Trip - Electric	283	70.1%	34.5%

The suggested proof test and proof test coverage is referenced in exida FMEDA report; WOO 17-04-071 R001.

Chapter 6. Product Support and Service Options

Product Support Options

If you are experiencing problems with the installation, or unsatisfactory performance of a Woodward product, the following options are available:

- Consult the troubleshooting guide in the manual.
- Contact the manufacturer or packager of your system.
- Contact the Woodward Full Service Distributor serving your area.
- Contact Woodward technical assistance (see “How to Contact Woodward” later in this chapter) and discuss your problem. In many cases, your problem can be resolved over the phone. If not, you can select which course of action to pursue based on the available services listed in this chapter.

OEM or Packager Support: Many Woodward controls and control devices are installed into the equipment system and programmed by an Original Equipment Manufacturer (OEM) or Equipment Packager at their factory. In some cases, the programming is password-protected by the OEM or packager, and they are the best source for product service and support. Warranty service for Woodward products shipped with an equipment system should also be handled through the OEM or Packager. Please review your equipment system documentation for details.

Woodward Business Partner Support: Woodward works with and supports a global network of independent business partners whose mission is to serve the users of Woodward controls, as described here:

- A **Full Service Distributor** has the primary responsibility for sales, service, system integration solutions, technical desk support, and aftermarket marketing of standard Woodward products within a specific geographic area and market segment.
- An **Authorized Independent Service Facility (AISF)** provides authorized service that includes repairs, repair parts, and warranty service on Woodward's behalf. Service (not new unit sales) is an AISF's primary mission.

A current list of Woodward Business Partners is available at:

<https://www.woodward.com/en/support/industrial/service-and-spare-parts/find-a-local-partner>

Product Service Options

The following factory options for servicing Woodward products are available through your local Full-Service Distributor or the OEM or Packager of the equipment system, based on the standard Woodward Product and Service Warranty (Woodward North American Terms and Conditions of Sale 5-09-0690) that is in effect at the time the product is originally shipped from Woodward or a service is performed:

- Replacement/Exchange (24-hour service)
- Flat Rate Repair
- Flat Rate Remanufacture

Replacement/Exchange: Replacement/Exchange is a premium program designed for the user who is in need of immediate service. It allows you to request and receive a like-new replacement unit in minimum time (usually within 24 hours of the request), providing a suitable unit is available at the time of the request, thereby minimizing costly downtime. This is a flat-rate program and includes the full standard Woodward product warranty (Woodward North American Terms and Conditions of Sale 5-09-0690).

This option allows you to call your Full-Service Distributor in the event of an unexpected outage, or in advance of a scheduled outage, to request a replacement control unit. If the unit is available at the time of the call, it can usually be shipped out within 24 hours. You replace your field control unit with the like-new replacement and return the field unit to the Full-Service Distributor.

Charges for the Replacement/Exchange service are based on a flat rate plus shipping expenses. You are invoiced the flat rate replacement/exchange charge plus a core charge at the time the replacement unit is shipped. If the core (field unit) is returned within 60 days, a credit for the core charge will be issued.

Flat Rate Repair: Flat Rate Repair is available for the majority of standard products in the field. This program offers you repair service for your products with the advantage of knowing in advance what the cost will be. All repair work carries the standard Woodward service warranty (Woodward North American Terms and Conditions of Sale 5-09-0690) on replaced parts and labor.

Flat Rate Remanufacture: Flat Rate Remanufacture is very similar to the Flat Rate Repair option with the exception that the unit will be returned to you in "like-new" condition and carry with it the full standard Woodward product warranty (Woodward North American Terms and Conditions of Sale 5-09-0690). This option is applicable to mechanical products only.

Returning Equipment for Repair

If a control (or any part of an electronic control) is to be returned for repair, please contact your Full-Service Distributor in advance to obtain Return Authorization and shipping instructions.

When shipping the item(s), attach a tag with the following information:

- Return authorization number
- Name and location where the control is installed
- Name and phone number of contact person
- Complete Woodward part number(s) and serial number(s)
- Description of the problem
- Instructions describing the desired type of repair

Packing a Control

Use the following materials when returning a complete control:

- Protective caps on any connectors
- Antistatic protective bags on all electronic modules
- Packing materials that will not damage the surface of the unit
- At least 100 mm (4 inches) of tightly packed, industry-approved packing material
- A packing carton with double walls
- A strong tape around the outside of the carton for increased strength

NOTICE

To prevent damage to electronic components caused by improper handling, read and observe the precautions in Woodward manual 82715, *Guide for Handling and Protection of Electronic Controls, Printed Circuit Boards, and Modules*.

Replacement Parts

When ordering replacement parts for controls, include the following information:

- The part number(s) (XXXX-XXXX) that is on the enclosure nameplate
- The unit serial number, which is also on the nameplate

Engineering Services

Woodward offers various Engineering Services for our products. For these services, you can contact us by telephone, by email, or through the Woodward website.

- Technical Support
- Product Training
- Field Service

Technical Support is available from your equipment system supplier, your local Full-Service Distributor, or from many of Woodward's worldwide locations, depending upon the product and application. This service can assist you with technical questions or problem solving during the normal business hours of the Woodward location you contact. Emergency assistance is also available during non-business hours by phoning Woodward and stating the urgency of your problem.

Product Training is available as standard classes at many of our worldwide locations. We also offer customized classes, which can be tailored to your needs and can be held at one of our locations or at your site. This training, conducted by experienced personnel, will assure that you will be able to maintain system reliability and availability.

Field Service engineering on-site support is available, depending on the product and location, from many of our worldwide locations or from one of our Full-Service Distributors. The field engineers are experienced both on Woodward products as well as on much of the non-Woodward equipment with which our products interface.

For information on these services, please contact one of the Full-Service Distributors listed at:

<https://www.woodward.com/en/support/industrial/service-and-spare-parts/find-a-local-partner>

Contacting Woodward's Support Organization

For the name of your nearest Woodward Full-Service Distributor or service facility, please consult our worldwide directory at <https://www.woodward.com/support>, which also contains the most current product support and contact information.

You can also contact the Woodward Customer Service Department at one of the following Woodward facilities to obtain the address and phone number of the nearest facility at which you can receive information and service.

Products Used in Electrical Power Systems	
Facility	Phone Number
Brazil	+55 (19) 3708 4800
China	+86 (512) 8818 5515
Germany	+49 (711) 78954-510
India	+91 (124) 4399500
Japan	+81 (43) 213-2191
Korea	+82 (51) 636-7080
Poland	+48 (12) 295 13 00
United States	+1 (970) 482-5811

Products Used in Engine Systems	
Facility	Phone Number
Brazil	+55 (19) 3708 4800
China	+86 (512) 8818 5515
Germany	+49 (711) 78954-510
India	+91 (124) 4399500
Japan	+81 (43) 213-2191
Korea	+82 (51) 636-7080
United States	+1 (970) 482-5811

Products Used in Industrial Turbomachinery Systems	
Facility	Phone Number
Brazil	+55 (19) 3708 4800
China	+86 (512) 8818 5515
India	+91 (124) 4399500
Japan	+81 (43) 213-2191
Korea	+ 82 (51) 636-7080
Poland	+48 (12) 295 13 00
United States	+1 (970) 482-5811

Technical Assistance

If you need to contact technical assistance, you will need to provide the following information. Please write it down here before contacting the Engine OEM, the Packager, a Woodward Business Partner, or the Woodward factory:

General

Your Name _____

Site Location _____

Phone Number _____

Fax Number _____

Prime Mover Information

Manufacturer _____

Turbine Model Number _____

Type of Fuel (gas, steam, etc.) _____

Power Output Rating _____

Application (power generation, marine,
etc.) _____

Control/Governor Information

Control/Governor #1

Woodward Part Number & Rev. Letter _____

Control Description or Governor Type _____

Serial Number _____

Control/Governor #2

Woodward Part Number & Rev. Letter _____

Control Description or Governor Type _____

Serial Number _____

Control/Governor #3

Woodward Part Number & Rev. Letter _____

Control Description or Governor Type _____

Serial Number _____

Symptoms

Description _____

If you have an electronic or programmable control, please have the adjustment setting positions or the menu settings written down and with you at the time of the call.

Revision History

Changes in Revision H—

- Added IECEx to Regulatory Compliance
- Added IECEx to Special Conditions of Safe Use

Changes in Revision G—

- Added new Figures 1-6a, 1-6b, 1-7a, and 1-7b
- Re-numbered Figures 1-7c, 1-8a, and 1-8b

Changes in Revision F—

- Added RoHS Directive to Regulatory Compliance section

Changes in Revision E—

- Added triple coil, single rod LVDT
- Added Figures 1-4a, 1-4b, 1-5a, 1-5b
- Renumbered Figures 1-5c and 1-6a
- Added Figure 1-6b

Changes in Revision D—

- Revised Inter-seal Vent Leakage in specifications table

Changes in Revision C—

- Added SIL 3 Certification
- Added Chapter 5 Safety Management

Changes in Revision B—

- Replaced warning box in Chapter 3
- Added Figures 3-1, 3-2, and 3-3 as examples to illustrate the warning on Bench Testing

Changes in Revision A—

- Updated IECEx compliance information for the LVDT

This Page Intentionally Left Blank

We appreciate your comments about the content of our publications.

Send comments to: industrial.support@woodward.com

Please reference publication **26703**.



B 2 6 7 0 3 : H



PO Box 1519, Fort Collins CO 80522-1519, USA
1041 Woodward Way, Fort Collins CO 80524, USA
Phone +1 (970) 482-5811

Email and Website—www.woodward.com

Woodward has company-owned plants, subsidiaries, and branches, as well as authorized distributors and other authorized service and sales facilities throughout the world.

Complete address / phone / fax / email information for all locations is available on our website.