

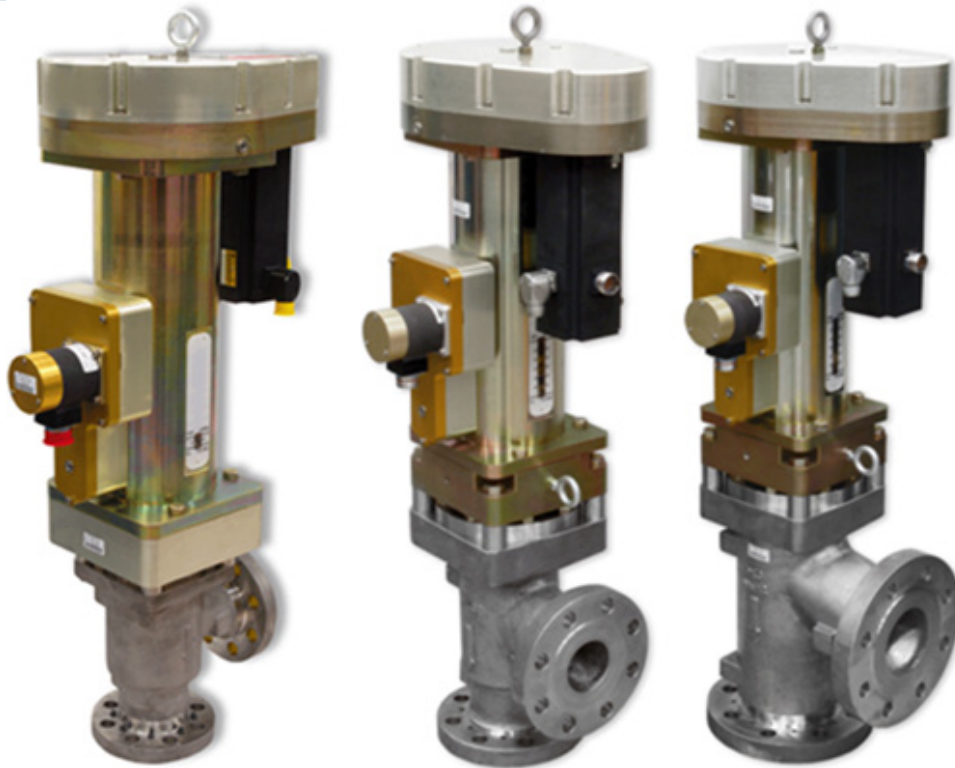

Product Manual 35045
(Revision J, 11/2025)
Original Instructions



**Standard Recovery Large Electric Sonic
Valve (SR LESV) Gas Fuel Control Valve**

2-inch, 3-inch, 4-inch

Installation and Operation Manual



**General
Precautions**

Read this entire manual and all other publications pertaining to the work to be performed before installing, operating, or servicing this equipment.

Practice all plant and safety instructions and precautions.

Failure to follow instructions can cause personal injury and/or property damage.



Revisions

This publication may have been revised or updated since this copy was produced. The latest version of most publications is available on the Woodward website.

[Woodward Industrial Support: Get Help](#)

If your publication is not there, please contact your customer service representative to get the latest copy.



Proper Use

Any unauthorized modifications to or use of this equipment outside its specified mechanical, electrical, or other operating limits may cause personal injury and/or property damage, including damage to the equipment. Any such unauthorized modifications: (i) constitute "misuse" and/or "negligence" within the meaning of the product warranty thereby excluding warranty coverage for any resulting damage, and (ii) invalidate product certifications or listings.



**Translated
Publications**

If the cover of this publication states "Translation of the Original Instructions" please note:

The original source of this publication may have been updated since this translation was made. The latest version of most publications is available on the Woodward website.

[Woodward Industrial Support: Get Help](#)

Always compare with the original for technical specifications and for proper and safe installation and operation procedures.

If your publication is not on the Woodward website, please contact your customer service representative to get the latest copy.

Revisions— A bold, black line alongside the text identifies changes in this publication since the last revision.

Woodward reserves the right to update any portion of this publication at any time. Information provided by Woodward is believed to be correct and reliable. However, no responsibility is assumed by Woodward unless otherwise expressly undertaken.

Contents

WARNINGS AND NOTICES	3
ELECTROSTATIC DISCHARGE AWARENESS	4
REGULATORY COMPLIANCE	5
CHAPTER 1. GENERAL INFORMATION	8
Introduction.....	8
*Corrosive Fuels Recommendations	9
SR-LESV Outline Drawings	10
Connector Pinouts.....	16
CHAPTER 2. DESCRIPTION	17
Electrical Mechanical Actuator Assembly	17
Brushless DC Motor	17
Resolver Position Feedback Sensors	17
Soft Stop Spring	17
Valve	17
CHAPTER 3. INSTALLATION	18
General.....	18
Piping Installation	20
Fuel Overboard Vent Connection	21
Valve Characteristic Data.....	21
Calibration	21
Valve/Actuator Configuration Settings	21
Electrical Connections.....	24
CHAPTER 4. MAINTENANCE AND HARDWARE REPLACEMENT	31
Maintenance.....	31
Hardware Replacement	31
Ball Screw Lubrication Procedure	32
Bearing Lubrication Procedure.....	34
Fuel Overboard Vent Port	35
CHAPTER 5. TROUBLESHOOTING	36
CHAPTER 6. PRODUCT SUPPORT AND SERVICE OPTIONS	38
Product Support Options	38
Product Service Options	38
Returning Equipment for Repair	39
Replacement Parts.....	40
Engineering Services	40
Contacting Woodward's Support Organization	40
Technical Assistance	41
REVISION HISTORY	42
DECLARATIONS	43

Illustrations and Tables

Figure 1-1a. Outline Drawing (2" SR LESV)	10
Figure 1-1b. Outline Drawing (2" SR LESV)	11
Figure 1-2a. Outline Drawing (3" SR LESV)	12
Figure 1-2b. Outline Drawing (3" SR LESV)	13
Figure 1-3a. Outline Drawing (4" SR LESV)	14
Figure 1-3b. Outline Drawing (4" SR LESV)	15
Figure 1-4. SR LESV Connector Pinouts	16
Figure 3-1. Illustration of Diverging Sleeve Screws	18
Figure 3-2. Illustration of Raised Face Style Diverging Sleeve	19
Figure 3-3. Illustration of Extension Style Diverging Sleeve	19
Figure 3-4. Power Connector	25
Figure 3-5. Motor Resolver Connectors	25
Figure 3-6. ID Module/Shaft Resolver Actuator Connector	26
Figure 3-7. Cable, Motor Resolver 1, Feedback Signal	27
Figure 3-8. Cable, Stem Shaft Resolver, Feedback Signal	28
Figure 3-9. Cable, Motor Power	29
Figure 3-10. Cable, Motor Resolver 2, Feedback Signal	30
Table 1-1. LESV Large Electric Sonic Valve Specifications	8
Table 3-1. Piping Loads According to Valve Size	20
Table 3-2. Valve Part Number Specific Parameters	22
Table 3-3. Valve Serial Number Specific Parameters	23
Table 5-1. Troubleshooting Symptom, Cause, and Remedy	36

Warnings and Notices

Important Definitions



This is the safety alert symbol used to alert you to potential personal injury hazards. Obey all safety messages that follow this symbol to avoid possible injury or death.

- **DANGER** - Indicates a hazardous situation, which if not avoided, will result in death or serious injury.
- **WARNING** - Indicates a hazardous situation, which if not avoided, could result in death or serious injury.
- **CAUTION** - Indicates a hazardous situation, which if not avoided, could result in minor or moderate injury.
- **NOTICE** - Indicates a hazard that could result in property damage only (including damage to the control).
- **IMPORTANT** - Designates an operating tip or maintenance suggestion.

WARNING

**Overspeed /
Overtemperature /
Overpressure**

The engine, turbine, or other type of prime mover should be equipped with an overspeed shutdown device to protect against runaway or damage to the prime mover with possible personal injury, loss of life, or property damage.

The overspeed shutdown device must be totally independent of the prime mover control system. An overtemperature or overpressure shutdown device may also be needed for safety, as appropriate.

WARNING

**Personal Protective
Equipment**

The products described in this publication may present risks that could lead to personal injury, loss of life, or property damage. Always wear the appropriate personal protective equipment (PPE) for the job at hand. Equipment that should be considered includes but is not limited to:

- Eye Protection
- Hearing Protection
- Hard Hat
- Gloves
- Safety Boots
- Respirator

Always read the proper Material Safety Data Sheet (MSDS) for any working fluid(s) and comply with recommended safety equipment.

WARNING

Start-up

Be prepared to make an emergency shutdown when starting the engine, turbine, or other type of prime mover, to protect against runaway or overspeed with possible personal injury, loss of life, or property damage.

Electrostatic Discharge Awareness

NOTICE

Electrostatic Precautions

Electronic controls contain static-sensitive parts. Observe the following precautions to prevent damage to these parts:

- Discharge body static before handling the control (with power to the control turned off, contact a grounded surface and maintain contact while handling the control).
- Avoid all plastic, vinyl, and Styrofoam (except antistatic versions) around printed circuit boards.
- Do not touch the components or conductors on a printed circuit board with your hands or with conductive devices.

To prevent damage to electronic components caused by improper handling, read and observe the precautions in Woodward manual **82715**, *Guide for Handling and Protection of Electronic Controls, Printed Circuit Boards, and Modules*.

Follow these precautions when working with or near the control.

1. Avoid the build-up of static electricity on your body by not wearing clothing made of synthetic materials. Wear cotton or cotton-blend materials as much as possible because these do not store static electric charges as much as synthetics.
2. Do not remove the printed circuit board (PCB) from the control cabinet unless absolutely necessary. If you must remove the PCB from the control cabinet, follow these precautions:
 - Do not touch any part of the PCB except the edges.
 - Do not touch the electrical conductors, the connectors, or the components with conductive devices or with your hands.
 - When replacing a PCB, keep the new PCB in the plastic antistatic protective bag it comes in until you are ready to install it. Immediately after removing the old PCB from the control cabinet, place it in the antistatic protective bag.

Regulatory Compliance

European Compliance for CE Marking

These listings are limited only to those units bearing the CE Marking.

EMC Directive Declared to 2014/30/EU COUNCIL DIRECTIVE of 26 February 2014 on the harmonization of the laws of the Member States relating to electromagnetic compatibility and all applicable amendments.

Pressure Equipment Directive: Directive 2014/68/EU on the harmonisation of the laws of the Member States relating to the making available on the market of pressure equipment.
2", 3", 4": PED Category II
PED Module H - Full Quality Assurance,

ATEX Directive: Directive 2014/34/EU on the harmonisation of the laws of the Member States relating to equipment and protective systems intended for use in potentially explosive atmospheres.
Zone 2, Category 3, Group II G, Ex ec IIC T3 Gc

Other European Compliance

Compliance with the following European Directives or standards does not qualify this product for application of the CE Marking:

Machinery Directive: Compliant as partly completed machinery with Directive 2006/42/EC of the European Parliament and the Council of 17 May 2006 on machinery.

RoHS Directive: Restriction of Hazardous Substances 2011/65/EU:
Woodward Turbomachinery Systems products are intended exclusively for sale and use only as a part of Large Scale Fixed Installations per the meaning of Art.2.4(e) of directive 2011/65/EU. This fulfills the requirements stated in Art.2.4(c) and as such the product is excluded from the scope of RoHS2.

ATEX Directive: Exempt from the non-electrical portion of the ATEX Directive 2014/34/EU due to no potential ignition sources per EN ISO 80079-36:2016 for Zone 2 installation.

Other International Compliance

IECEX (LELA Actuator): Certified for use in explosive atmospheres per Certificate IECEX CSA 14.0013X
Ex ec IIC T3 Gc

EAC Customs Union

These listings are limited only to those units with labels, marking, and manuals in Russian language to comply with their certificates and declaration.

EAC Customs Union (Marked): Certified to Technical Regulation CU 012/2011 for use in potentially explosive atmospheres per Certificate RU C-US.ГБ08.B.01076 as 2Ex nA IIC T3 Gc X for electrical and II Gc TX for non-electrical portions of the valve.

EAC Customs Union: Declared to Technical Regulation CU 032/2013 on the safety of equipment operating under excessive pressure. Declaration of Conformity Registration No: RU Д-US.MЮ62.B.02150 for 2, 3, and 4 inch valves.

EAC Customs Union: Declared to Technical Regulation CU 010/2011 on the safety of machinery and equipment. Declared to Technical Regulation CU 020/2011 on Electromagnetic Compatibility of Technical Equipment. Declaration of Conformity Registration No: RU Д-US.AY14.B.25099.

North American Compliance

These listings are limited only to those units bearing the CSA Marking.

CSA (Actuator) CSA Certified for Class I, Division 2, Groups A, B, C, & D, T3 at 93 °C Ambient.
For use in Canada and the United States Certificate 1635932

Actuator is certified for North America as on-engine systems component connected to the certified Digital Valve Positioner.

Special Conditions for Safe Use:

- Mating connectors must be installed to maintain IP55 rating.
- Connect the ground terminal to earth ground.
- Maximum ambient temperature 93 °C (200 °F).
- Use supply wires suitable for 10 °C (18 °F) above surrounding ambient.

Compliance with the Machinery Directive 2006/42/EC noise measurement and mitigation requirements is the responsibility of the manufacturer of the machinery into which this product is incorporated.

Wiring must be in accordance with North American Class I, Division 2, or European Zone 2, Category 3 wiring methods as applicable, and in accordance with the authority having jurisdiction.

 WARNING	EXPLOSION HAZARD—Do not remove covers or connect/disconnect electrical connectors unless power has been switched off or the area is known to be non-hazardous.
	Substitution of components may impair suitability for Class I, Division 2 or Zone 2.

 AVERTISSEMENT	RISQUE D'EXPLOSION—Ne pas enlever les couvercles, ni raccorder / débrancher les prises électriques, sans vous en assurer auparavant que le système a bien été mis hors tension; ou que vous situez bien dans une zone non explosive.
	La substitution de composants peut rendre ce matériel inacceptable pour les emplacements de Classe I, Division 2 ou Zone 2.

Safety Symbols



Direct Current



Alternating Current



Both Alternating and Direct Current



Caution, risk of electrical shock



Caution, refer to accompanying documents



Protective conductor terminal



Frame or chassis terminal

Chapter 1.

General Information

Introduction

The Large Electric Sonic Valve (LESV) controls the flow of gas fuel to the combustion system of an industrial or utility gas turbine. The integral electric actuator consists of a brushless dc motor, resolver for motor commutation and position sensing, valve stem resolver for motor resolver verification, fail-safe spring for fail-safe operation, and a soft stop for fail-safe operations. The LESV utilizes a device (ID Module) containing all the configuration and calibration information that is read by the Digital Valve Positioner (DVP) when the valve/actuator is connected and powered up.

This valve is intended to operate only with a Woodward Digital Valve Positioner (DVP). Contact your sales person for part numbers for your specific applications.

Table 1-1. LESV Large Electric Sonic Valve Specifications

Description	2,3, and 4 inch (51, 76 and 102 mm) electrically actuated natural gas sonic metering valve, ASME B16.34 Class 300
Mean Time Between Failure (MTBF)	149 000 hrs. operation combined metering valve per valve/actuator/DVP/cable subsystem.
Ambient Temperature Range	-29 to +93 °C (-20 to +200 °F)
Approximate Weights	2" – 113 kg/250 lb. 3" – 124 kg/275 lb. 4" – 174 kg/384 lb.
ACTUATOR	
Description	Brushless dc motor with dual position feedback sensors.
Coil	Class H insulation
Failure Mode	Spring type to drive valve to safe position with loss of signal (Fail Close).
Bandwidth	35 rad/s (5.57 Hz) with no more than 6 dB attenuation and less than 180 degrees phase loss at $\pm 2\%$ magnitude and minimum supply voltage at DVP
Visual Position Indication	Yes
Ingress Protection	IP55
Response Time	400 ms Closing Time (measured from 90%-10% during a 100%-0% step)
DVP Input Voltage (typical)	220 Vdc
DVP Input Voltage (Max)	300 Vdc
DVP Input Voltage (Min) (for full dynamic performance)	112.5 Vdc

Table 1-1. LESV Large Electric Sonic Valve Specification (cont'd.)

VALVE	
Operating Fluid	Natural Gas*
Gas Filtration	25 µm absolute at 75 beta requirement
Valve Flange Connection	Class 300 Flange
Min Fluid Temperature	-29 °C (-20 °F)
Max Fluid Temperature	260 °C (500 °F)
Max Fluid Temperature @ Discharge Flange	277 °C (530 °F)
Min Fluid Pressure	0 kPa (0 psig)
Max Fluid Pressure	3448 kPa (500 psig)
Proof Test Pressure/ Production	7757 kPa (1125 psig)
Burst Pressure	25510 kPa (3700 psig)
Overboard Leakage	<15 cm ³ /min as shipped (see Fuel Overboard Vent Port section).
Trim Sizes	4" – Cg 3655
	3" – Cg 2900, Cg 2000
	2" – Cg 1200, Cg 650
Seat Leakage	Class IV per FCI 70-2

*Corrosive Fuels Recommendations

Woodward valves are designed to meet the full performance and lifetime specifications only when operated in an environment with less than 20 ppm H₂S. Woodward has no definitive performance experience for these valves operating above 20 ppm H₂S and therefore recommends an annual inspection along with a scheduled overhaul interval of no more than 20,000 operating hours or two years, whichever comes first. **This is a change to our normal recommendation for overhaul at 48,000 operating hours.** During overhaul the valve will be evaluated, and further recommendations can be provided which may include an update to the overhaul schedule.

NOTE: Regarding Atmospheric Environment, Woodward products are designed based on non-corrosive gas conditions. Besides particulates, the atmospheric environment may also contain corrosive gases such as hydrogen sulfide, sulfur dioxide, nitrous oxide, and chlorine. Product printed circuit assemblies are basically conformal coated with a specialized polyacrylate that provides protection from corrosive gaseous sulfur compounds and corrosion accelerants such as NO_x and chlorine. By necessity, some areas cannot be coated—such as connectors, jumpers, test points, and field terminations. The larger conductor spacing, thicker metallization, and corrosion resistant plating of these uncoated areas will mitigate the effects of corrosion for a time but not prevent eventual damage.

The sulfur resistant coating will provide protection for coated components in moderately severe atmospheric environments as described by ISA S71.04-19852 level "G2", and IEC 721-3-3 1994 TABLE 4 Class 3C2 (Urban Industrial, Heavy Traffic). See Tables 2 and 3 of [Woodward Application Note 51530](#). Long-term use in more severe environments is not recommended because some critical reactive metal connection surfaces cannot be coated and corrosion will occur at a rate determined by the corrosive gas concentrations and mixtures, materials, temperature, and humidity.

SR-LESV Outline Drawings

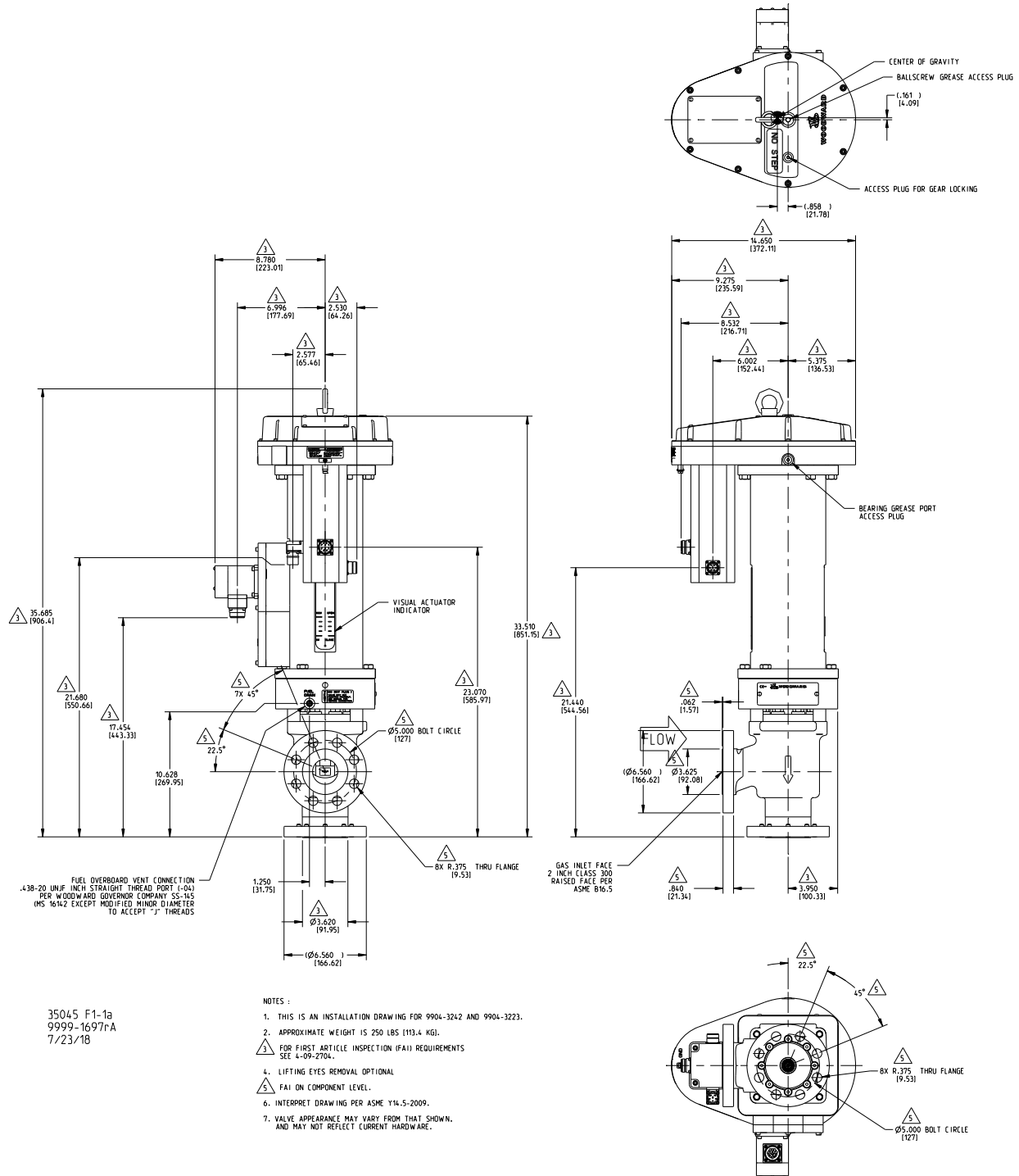
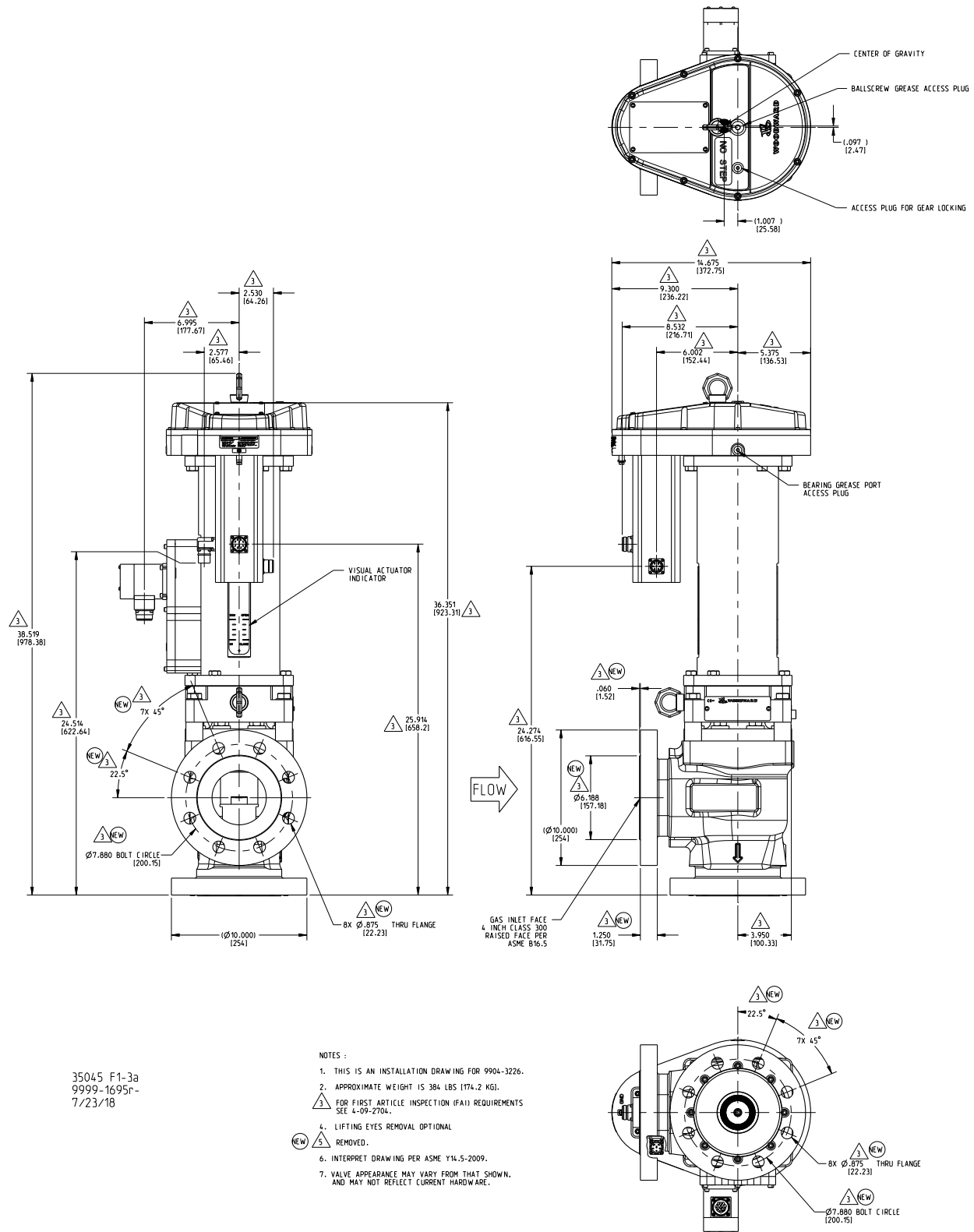

Figure 1-1a. Outline Drawing (2" SR LESV)



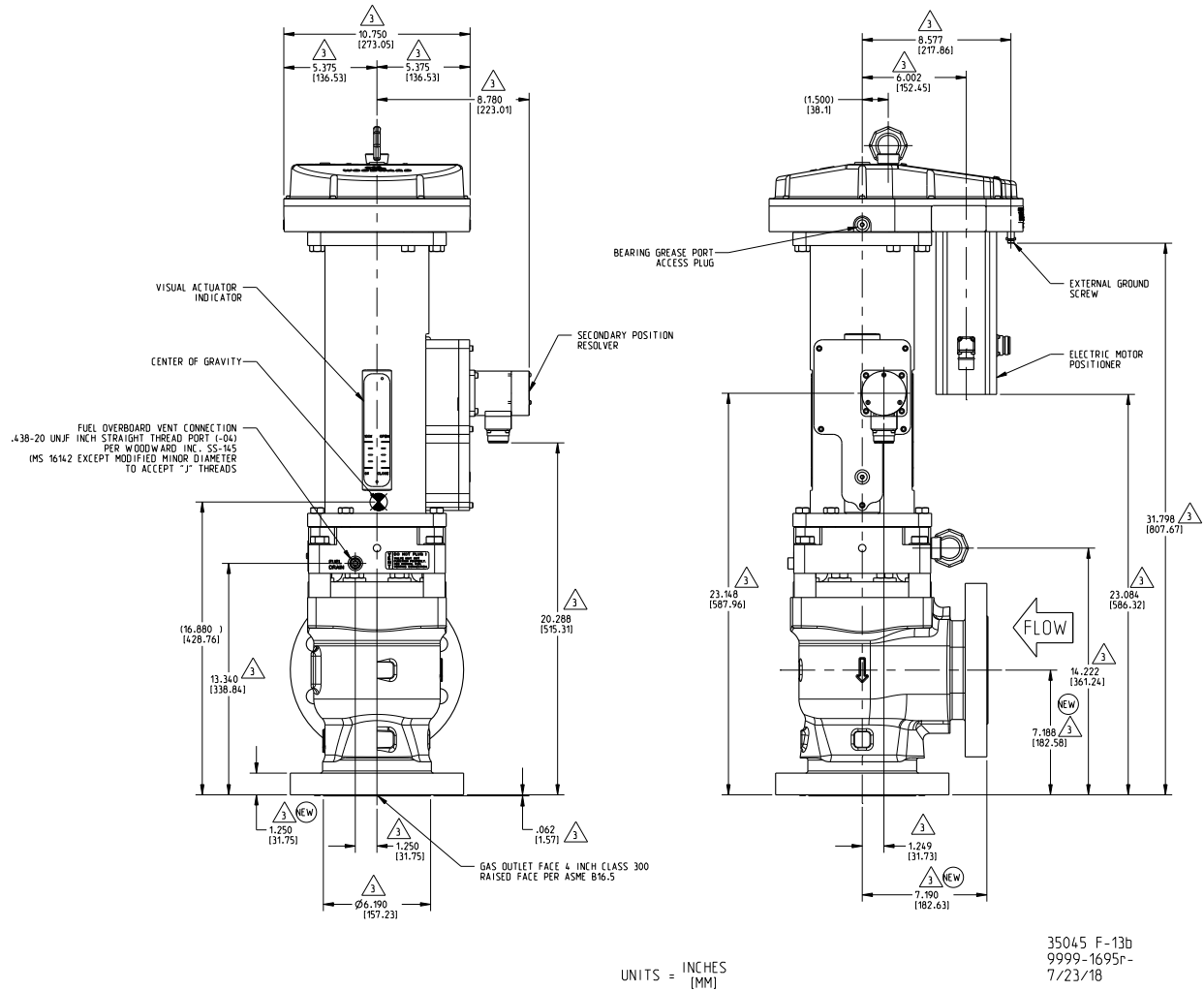
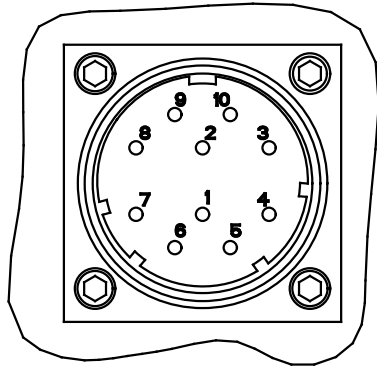

Figure 1-3b. Outline Drawing (4" SR LESV)

Connector Pinouts

PIN DEFINITION FOR
MOTOR SIGNAL CONNECTOR
(RESOLVER 1)
M83723/83-G-16-10-N



DETAIL A
SCALE 2.0

PIN 1	EXC +
PIN 2	EXC -
PIN 3	COS +
PIN 4	COS -
PIN 5	SIN +
PIN 6	SIN -
PIN 7	SEAL PLUG
PIN 8	SEAL PLUG
PIN 9	SEAL PLUG
PIN 10	SEAL PLUG

PIN DEFINITION FOR
SHAFT RESOLVER CIRCULAR CONNECTOR
M83723/83-G-18-14-N

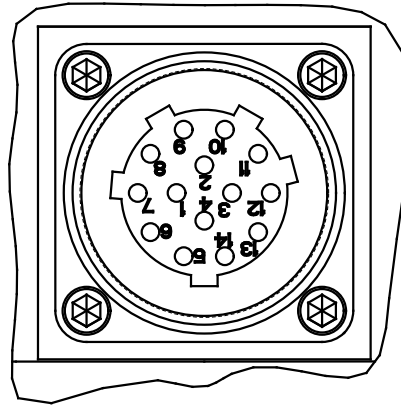

DETAIL B
SCALE 2.0

PIN 1	COS +
PIN 2	COS -
PIN 3	SIN +
PIN 4	SIN -
PIN 5	EXC +
PIN 6	EXC -
PIN 7	POWER
PIN 8	GROUND
PIN 9	ID CAN 3 H
PIN 10	ID CAN 3 L
PIN 11	SEAL PLUG
PIN 12	SEAL PLUG
PIN 13	SEAL PLUG
PIN 14	SEAL PLUG

PIN DEFINITION FOR
MOTOR POWER CONNECTOR
M23 POWER CONNECTOR
RDE CONNECTOR P/N = SF-5EPIN8AAD00-7MP

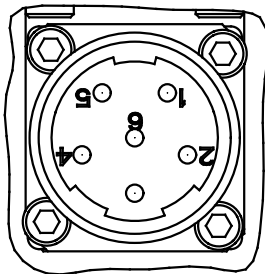

DETAIL C
SCALE 2.0

PIN 1	L1-U
PIN 2	CHASSIS GRD
GRD	BLANK PIN
PIN 4	L3-W
PIN 5	L2-V
PIN 6	BLANK PIN

PIN DEFINITION FOR
MOTOR SIGNAL CONNECTOR
(RESOLVER 2)
M83723/83-G-14-07-N

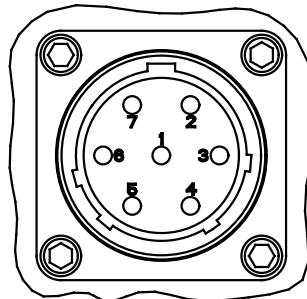

DETAIL D
SCALE 2.0

PIN 1	EXC +
PIN 2	EXC -
PIN 3	COS+
PIN 4	COS -
PIN 5	SIN+
PIN 6	SIN-
PIN 7	SEAL PLUG

Figure 1-4. SR LESV Connector Pinouts

Chapter 2. Description

Electrical Mechanical Actuator Assembly

The electrical-mechanical actuator consists of a brushless dc motor that provides torque, an integral resolver for motor commutation and position feedback to the controller, a valve stem resolver for motor resolver verification, and a high-efficiency ball screw for rotary-to-linear motion conversion. The actuator also contains a fail-safe spring designed to extend the actuator if power is removed from the actuator.

- A soft-stop spring to dissipate motor rotor inertia during fail-safe shutdown and prevent ball screw damage
- A cam follower to provide opposing torque during slew operations
- A lifting eye to aid installation

Brushless DC Motor

The motor used on the LESV is a permanent magnet, electrically commutated, brushless dc motor. The components used in the motor are rated for service from -40 to $+155$ °C (-40 to $+311$ °F). The motor is a permanently lubricated assembly with a sealed enclosure rating of IP55.

Resolver Position Feedback Sensors

The primary position feedback transducer is the resolver that is integral to the dc brushless motor. The actuator also has a valve stem resolver. This resolver is used as a watchdog function of the primary motor control, to prevent runaway conditions and to ensure that the primary motor resolver is reading correctly. Linear shaft motion is converted to angular rotation for the valve stem resolver through a linkage. Parameter files are loaded onto the DVP to specifically match the valve characteristics in order to obtain the most accurate position sensing.

Soft Stop Spring

Integral to the actuator is a soft stop spring. This provides a bumper like action if the actuator is driven hard into the fully extended position. This will occur only on loss of power, certain wiring faults, and in rare cases, internal fault conditions within the positioner. The soft stop mechanism is not used when the positioner is controlling the actuator. Although the positioner will rapidly drive the actuator towards the minimum position, it also decelerates the actuator as the actuator approaches the mechanical minimum stop. Under the control of the positioner, the actuator should not reach the mechanical minimum stop at a high velocity.

Valve

The SonicFlo contoured plug valve consists of a valve housing, metering plug, diverging sleeve, pilot sleeve/bonnet, and actuator adapter. The metering elements of this valve are a contoured plug and a hardened seat. The plug is contoured to provide various Cg versus position flow characteristics from 0% to 100% stroke. Please contact Woodward for available trim sizes and Cg profiles.

Chapter 3. Installation

General

See the outline drawings (Figures 1-1 through 1-4) for:

- Overall dimensions
- Process piping flange locations
- Electrical connections
- Lift points and center of gravity

Installation attitude does not affect actuator or fuel valve performance, but a vertical position is generally preferred to conserve floor space as well as ease of making electrical and fuel connections. The LESV is designed for support by the piping flanges alone; additional supports are neither needed nor recommended. Do not use this valve to provide support to any other component in the system. The piping should be aligned and adequately supported such that excessive piping loads are not transmitted to the valve body.

! WARNING

EXPLOSION HAZARD—The surface temperature of this valve approaches the maximum temperature of the applied process media. It is the responsibility of the user to ensure that the external environment contains no hazardous gases capable of ignition in the range of the process media temperatures.

! WARNING

Do not operate the valve without proper support for the diverging sleeve. **IF BENCH TESTING THE VALVE, ENSURE THAT ASME/ANSI RATED FLANGES ARE GASKETED AND INSTALLED OVER THE INLET AND DISCHARGE FLANGES WITH THE BOLTS PROPERLY TORQUED.** The diverging sleeve screws by themselves are not designed to hold pressure loads. Failure to comply with this warning may result in personal injury. Do not place hands inside valve body during inspection, cleaning, or operation.

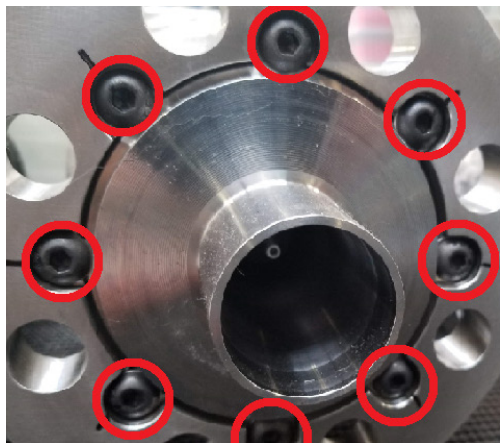

**DIVERGING
SLEEVE
SCREWS -
DO NOT
PRESSURE
LOAD!**

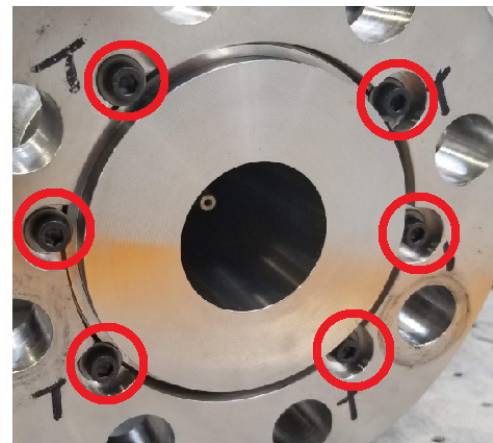

Figure 3-1. Illustration of Diverging Sleeve Screws

Diverging Sleeve assembly screws are not designed to hold pressure loads. If bench testing, do not apply pressure to the valve without ANSI flanges (see below figures).

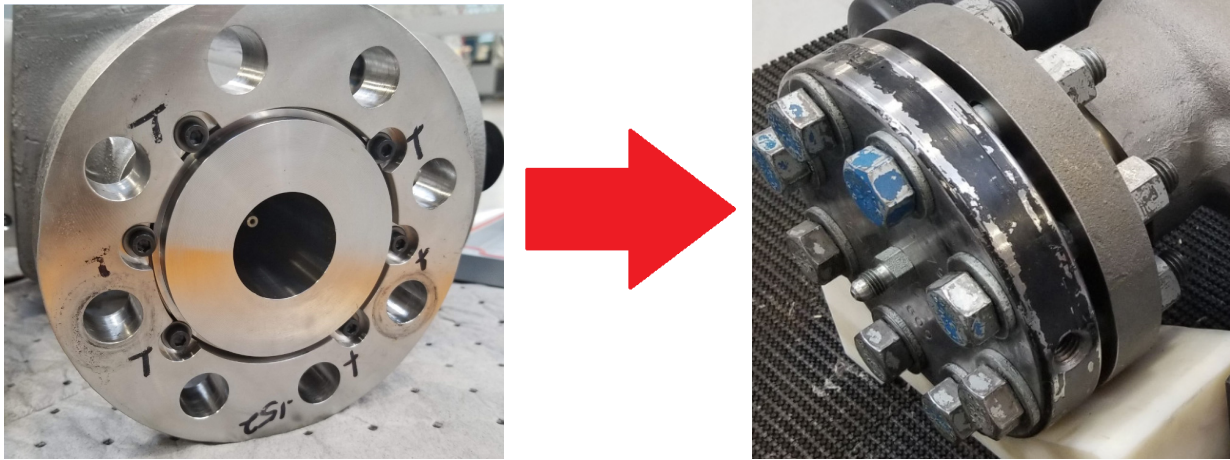

Figure 3-2. Illustration of Raised Face Style Diverging Sleeve

Raised Face style diverging sleeves should be secured with a blind flange when bench testing

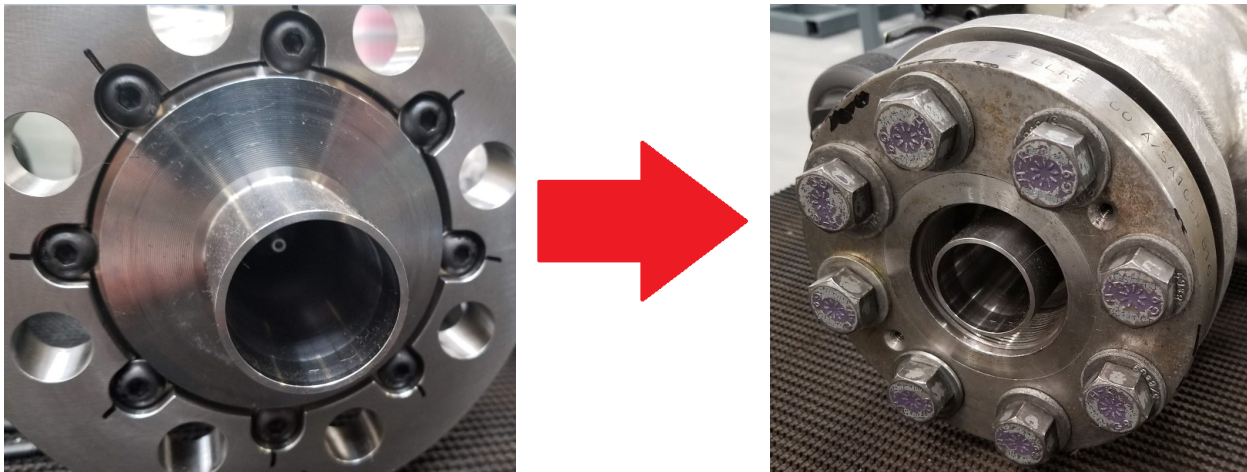

Figure 3-3. Illustration of Extension Style Diverging Sleeve

Extension style diverging sleeves should be secured with a threaded or weld neck style flange when bench testing

⚠ WARNING

Due to typical noise levels in turbine environments, hearing protection should be worn when working on or around the Large Electric Sonic Valve. Noise levels of greater than 90 dB are possible.

⚠ WARNING

The surface of this product can become hot enough or cold enough to be a hazard. Use protective gear for product handling in these circumstances. Temperature ratings are included in the specification section of this manual.

⚠ WARNING

Lift or handle the valve only by using the eyebolts.

The LESV is not designed to be a step or to support the weight of a person.

NOTICE

External fire protection is not provided in the scope of this product. It is the responsibility of the user to satisfy any applicable requirements for their system.

Piping Installation

Refer to ANSI B16.5 for details of flange, gasket, and bolt types and dimensions. Verify that the process piping face-to-face dimensions meet the requirements of the outline drawings (Figures 1-1 through 1-4) within standard piping tolerances. The valve should mount between the piping interfaces such that the flange bolts can be installed with only manual pressure applied to align the flanges. Mechanical devices such as hydraulic or mechanical jacks, pulleys, chain-falls, or similar equipment should never be used to force the piping system to align with the valve flanges.

ASTM/ASME grade bolts or studs should be used to install the valve into the process piping. The length and diameter of the bolts and studs shall conform to ANSI B16.5 according to the valve flange size and class.

Flange gasket materials should conform to ANSI B16.20. The user should select a gasket material which will withstand the expected bolt loading without injurious crushing, and which is suitable for the service conditions.

When installing the valve into the process piping, it is important to properly torque the studs/bolts in the appropriate sequence in order to keep the flanges of the mating hardware parallel to each other. A two-step torque method is recommended. Once the studs/bolts are hand-tightened, torque the studs/bolts in a crossing pattern to half the required torque. Once all studs/bolts have been torqued to half the appropriate value, repeat the pattern until the rated torque value is obtained.

Do not insulate the valve or actuator. Insulation may be used on the inlet horizontal leg of the pipe. There should be no insulation around the outlet flange of the valve or the outlet riser pipe. If the outlet riser pipe is longer than six diameters, insulation may be used below the 6-diameter mark. This is because the purge temperature is extremely hot and may damage the valve seals.

Note: The Valve discharge flange must not exceed 277°C (530°F) when the valve is closed and the downstream circuit is being purged.

Piping loads that can be considered “typical” have been used in the design of the housing to ensure that there is not an adverse effect from the stresses applied to the housing from the inlet and outlet piping. The loads which were used in the design of these housings are (and should not be exceeded):

Table 3-1. Piping Loads According to Valve Size

Valve Size	Max Axial Pipe Force	Max Pipe Moment
50 mm (2 inch)	3600 N (809.3 lbs.)	2200 N·m (1622.6 lb-ft)
80 mm (3 inch)	5400 N (1214 lbs.)	3300 N·m (2434 lb-ft)
100 mm (4 inch)	7200 N (1618 Lbs)	4400 N·m (3245.3 lb-ft)

Fuel Overboard Vent Connection

There is a fuel overboard vent port that must be vented to a safe location. In normal operation, this vent should have very low leakage.

NOTICE

Never plug the fuel overboard vent port, which could cause the valve to malfunction or to operate improperly.

Valve Characteristic Data

Flow testing is conducted on every valve before shipment. Results from this flow testing produce Cg versus position characteristics of the valve. Each valve must demonstrate predetermined Cg characteristics before it can be shipped.

Calibration

The actuator and controller perform an automatic rigging procedure. When the actuator controller is activated, it performs an automatic rigging procedure that checks system health and verifies the valve is in the proper position. No additional steps are required from the operator.

Valve/Actuator Configuration Settings

The LESV utilizes a device (ID Module) containing all the configuration and calibration information that is read by the Digital Valve Positioner (DVP) when the valve/actuator is connected and powered up. Initial configuration settings for the valve/actuator do not need to be entered into the DVP due to the ID Module communicating directly with the positioner. However, in the unlikely event the configuration settings must be entered manually, the following tables outline the necessary configuration settings for the LESV. These configuration settings are broken up into three groups: User Configuration Parameters, Valve Part Number Specific Parameters, and Valve Serial Number Specific Parameters. Some of the configuration settings include factory calibration information. Please contact Woodward with the valve part number and serial number for the data containing the specific calibration and configuration settings if the need arises. Many of these parameters are accessible via the Woodward Service Tool.

User Configuration Parameters

The User Configuration Parameters are used in the DVP to define the interface between the DVP and the turbine control system. Examples of these include the demand type selection, analog input scaling, discrete input and output configurations, etc. For a complete description of all the options for the User Configuration Parameters, please see the DVP product manual.

Valve Part Number Specific Parameters

These parameters define the settings based on a particular valve type (part number). Every valve of the same type, regardless of serial number, will have the same settings. Please refer to the table below for a definition of these settings. For instructions on how to enter these values, please refer to the DVP manual.

NOTICE

Please contact Woodward for the correct settings for your application.

Table 3-2. Valve Part Number Specific Parameters

Parameter Name	Description	Value/Units
ValveTypeId.		
IdModuleVersion	Parameter set version	1 = Rev 0 2 = Rev 1, etc.
ValveType	Selects valve type	9 = 1.5" Stroke LESV
ValveProductCode	Upper level part number of valve assembly	xxxx-xxxx
ValveProductRev	EC Revision of Valve Assembly	1 = NEW 2 = A 3 = B, etc. 50 = Rev 0 51 = Rev 1, etc.
BLDCPosStateParams.		
MinCheckCurrent	Current to close valve during min startup check	amps
MaxCheckCurrent	Current to preload valve in opening direction during min startup check	amps
MotorDirectioncheckLimit	Min movement in the closing direction during startup check to avoid a motor direction error	% of electrical revolution
SetPosZeroCutOffParams.		
Mode	Turns on or off the zero cut off function	0 = Off 1 = On
LowLimit	Zero cut off will be turned on below this stroke	%
HighLimit	Zero cut off will be turned off above this limit	%
DelayTime	Delay time before zero cut off is turned on	ms
ModelPositionErrParams.		
PosErrMotorAlarmTime	Motor resolver delay time before a position error is flagged as an alarm	sec
PosErrMotorAlarmLimit	Alarm limit for error allowed between the position demand and the motor resolver feedback	%
PosErrMotorShutdownTime	Motor resolver delay time before a position error creates a shutdown	sec
PosErrMotorShutdownLimit	Shutdown limit for error allowed between the position demand and the motor resolver feedback	%
PosErrShaftAlarmTime	Shaft resolver delay time before a position error is flagged as an alarm	sec
PosErrShaftAlarmLimit	Alarm limit for error allowed between the position demand and the shaft resolver feedback	%
PosErrShaftShutdownTime	Shaft resolver delay time before a position error creates a shutdown	sec
PosErrShaftShutdownLimit	Shutdown limit for error allowed between the position demand and the shaft resolver feedback	%
NoiseFilterParams.		
NoiseFilterMode	Selects noise filter mode	
Bandwidth	Input noise filter bandwidth	Hz
Damping	Input noise filter damping	Typical 2 nd order response is 1.0
Threshold	Below this threshold the gain setting will be used, above this threshold the gain setting will be set to 1.0	%
Gain	Input noise filter gain	

Table 3-2. Valve Part Number Specific Parameters (cont'd.)

Parameter Name	Description	Value/Units
PaceMakerParams.		
Mode	Turns on or off the pace maker function	0 = Off 1 = On
DelayTime	Delay time between pace maker pulses	min
PositionStep	Position demand magnitude for the pace maker pulse	%
ImpulseHalfDuration	Time pulse remains high, also time pulse remains low	ms

Valve Serial Number Specific Parameters

Each valve, regardless of valve type or part number, will have a set of unique settings corresponding to the calibration process done on each unit at the factory. Refer to the table below for a definition of these settings. Please contact Woodward in the event these values need to be entered into the DVP.

Table 3-3. Valve Serial Number Specific Parameters

Parameter Name	Description	Value
ValveTypeId.		
ValveSerialNum	Valve assembly serial number	Factory Calibrated
ResolverScalingParams.		
Shaft1Resolver.LelaScaling.Length1	Secondary resolver calibration	Factory Calibrated
Shaft1Resolver.LelaScaling.Length2	Secondary resolver calibration	Factory Calibrated
Shaft1Resolver.LelaScaling.Xoffset	Secondary resolver calibration	Factory Calibrated
Shaft1Resolver.LelaScaling.YatZero	Secondary resolver calibration	Factory Calibrated
Shaft1Resolver.LelaScaling.YatMax	Secondary resolver calibration	Factory Calibrated
Shaft1Resolver.LelaScaling.ROffset	Secondary resolver calibration	Factory Calibrated
Shaft1Resolver.LelaScaling.RRollOver	Secondary resolver calibration	Factory Calibrated
BLDCPosStateParams.		
MinCheckMotorResMin	Startup diagnostic limit	Factory Calibrated
MinCheckMotorResMax	Startup diagnostic limit	Factory Calibrated
MinCheckShaftResMin	Startup diagnostic limit	Factory Calibrated
MinCheckShaftResMax	Startup diagnostic limit	Factory Calibrated
MaxCheckMotorResMin	Startup diagnostic limit	Factory Calibrated
MaxCheckMotorResMax	Startup diagnostic limit	Factory Calibrated
MaxCheckShaftResMin	Startup diagnostic limit	Factory Calibrated
MaxCheckShaftResMax	Startup diagnostic limit	Factory Calibrated
MotorResolverOffset	Startup diagnostic limit	Factory Calibrated
SetPosOffsetParams.Offset	Calibration position offset	Factory Calibrated

Electrical Connections

! WARNING

Due to the hazardous location listings associated with this product, proper wire type and wiring practices are critical to operation.

NOTICE

Do not connect any cable grounds to “instrument ground”, “control ground”, or any non-earth ground system. Make all required electrical connections based on the wiring diagrams (Figure 1-6).

! CAUTION

For best noise immunity, and to prevent damage to on-board actuator instruments, the motor power cables should be run in separate cable trays or conduits from the motor resolver cables and any other low-level signal cables.

This product is designed for use with three (or 4 with optional redundant motor resolver) dedicated cables that connect the Digital Valve Positioner to the LESV assembly. These cables must be used for the system to meet all CSA, ATEX, EMC, and LVD requirements. Please contact Woodward for the appropriate cable configuration.

Refer to the outline drawings (Figures 1-1 through 1-4) for location of grounding lug in order to properly earth ground the LESV.

Figures 3-4, 3-5, 3-6, and 3-7 show drawings typical of the four dedicated cables used to connect the LESV valve to the DVP driver. The drawings in these figures include wiring diagrams and connector descriptions. Application specific requirements such as termination at the DVP, length and environmental conditions, etc., may result in a custom implementation of these cables by the customer.

! WARNING

Electrical circular connectors must be properly seated and tightened in order to provide correct performance, to eliminate potential shock hazard, and to maintain the LESV's IP rating.

Connect external ground terminal of actuator to the earth ground. This must be the same grounding system as the driver's earth ground.

! WARNING

The LESV are to be used only with the Woodward Digital Valve Positioner (DVP).

Wiring must be in accordance with North American Class I, Division 2 or International Zone 2 wiring methods as applicable and in accordance with the authority having jurisdiction.

Firmly seat all electrical connections on the appropriate connector. A seating torque of 22 inch pounds (2.5 Nm) should be applied to the power connector to ensure proper connection.

Power Connector

The mating power cable connector shall be installed hand-tight followed by a final torque of 2.5 Nm (22 lb.-in) to meet the IP rating.

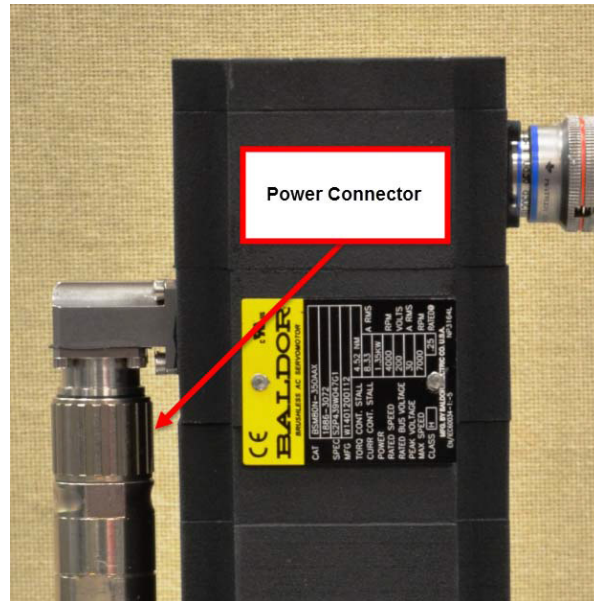

Figure 3-4. Power Connector

Note: Actual connector orientation on motor may appear different than that shown.

Motor Resolver Connectors (Two Resolvers)

Install these two mating cable connectors by hand, so that the red line is no longer visible and the connector cannot be turned any further.

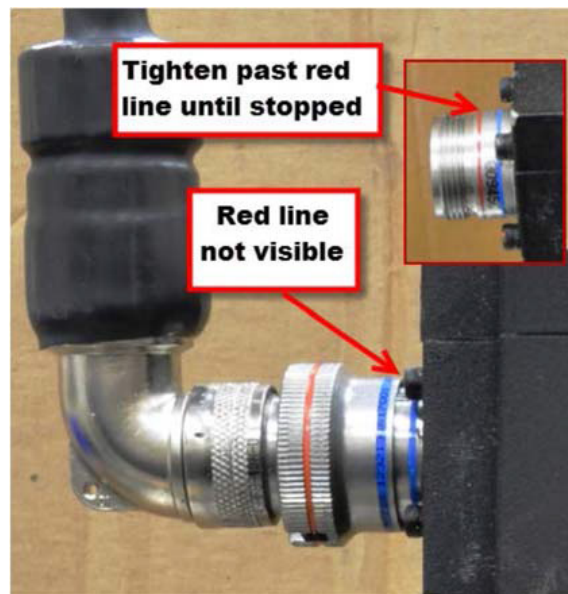

Figure 3-5. Motor Resolver Connectors

ID Module/Shaft Resolver Actuator Connector

Install the mating cable connector by hand, so that the red line is no longer visible and the connector cannot be turned any further.

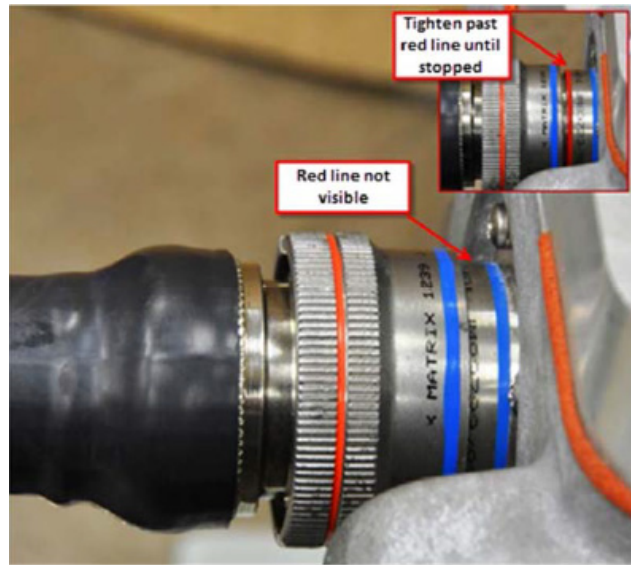

Figure 3-6. ID Module/Shaft Resolver Actuator Connector

Note: Actual connector location on actuator may appear different than that shown.

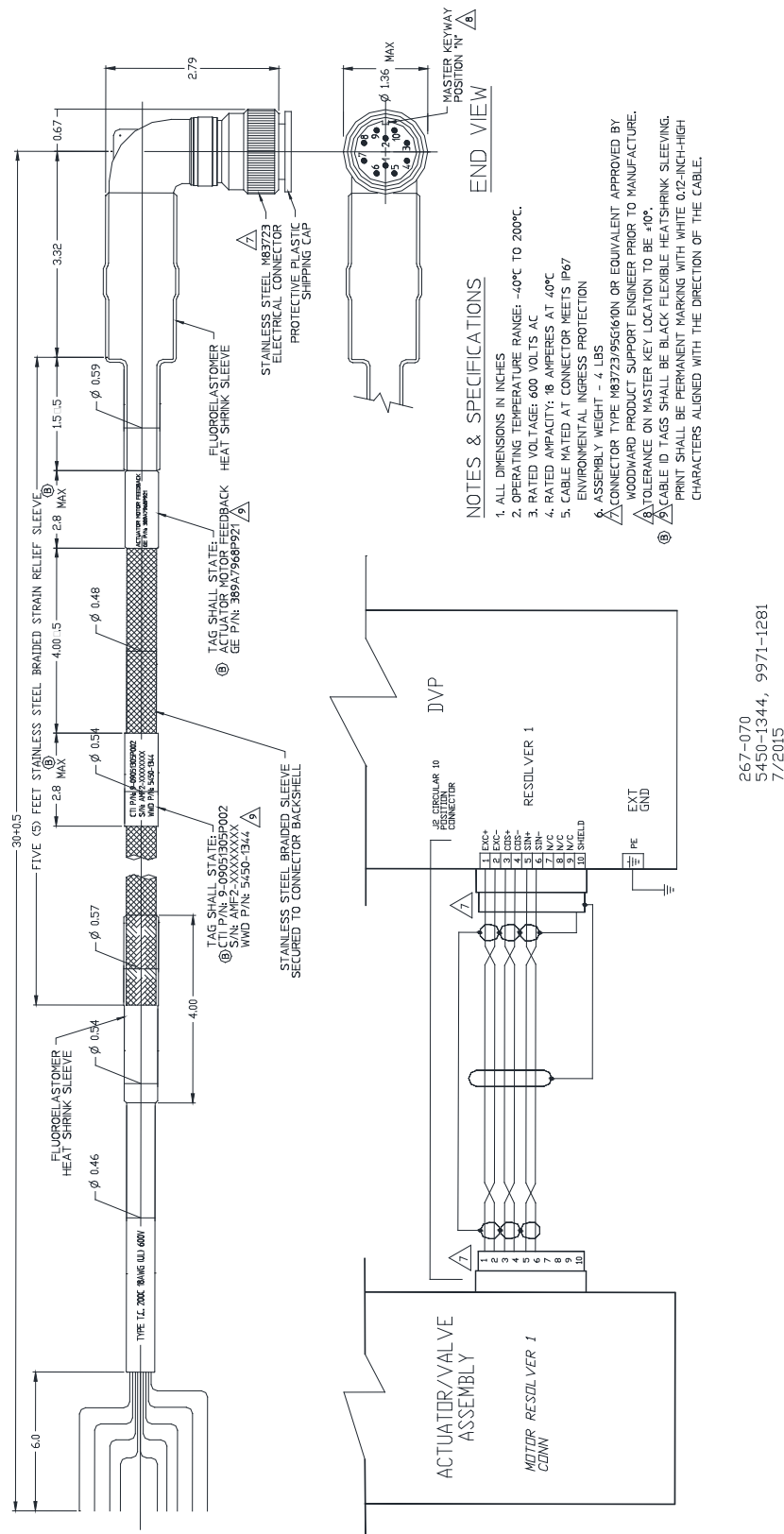
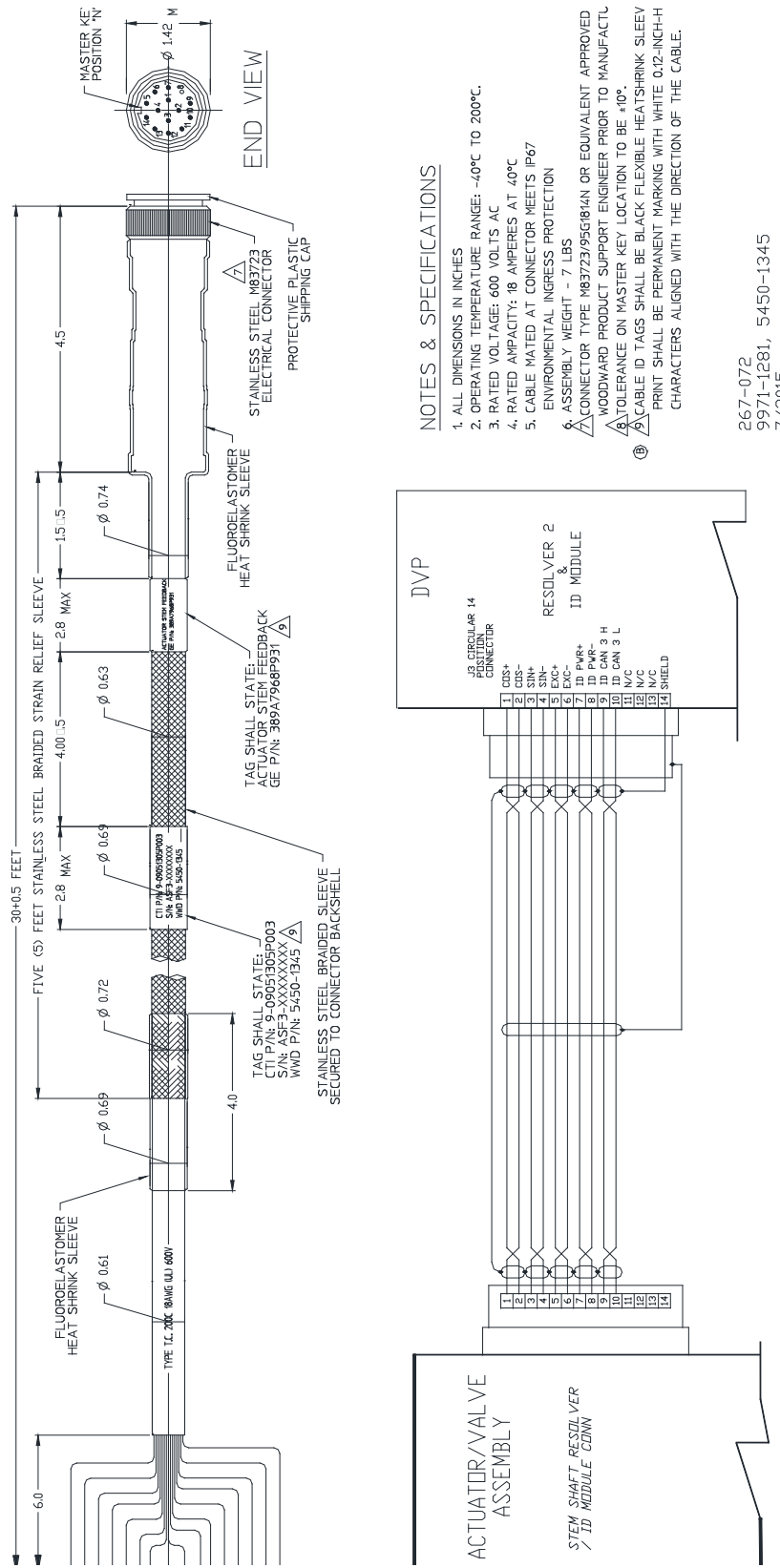

Figure 3-7. Cable, Motor Resolver 1, Feedback Signal



NOTES & SPECIFICATIONS

1. ALL DIMENSIONS IN INCHES
2. OPERATING TEMPERATURE RANGE: -40°C TO 200°C.
3. RATED VOLTAGE: 600 VOLTS AC
4. RATED AMPACITY: 18 AMPERES AT 40°C
5. CABLE MATED AT CONNECTOR MEETS IP67 ENVIRONMENTAL INGRESS PROTECTION
6. ASSEMBLY WEIGHT - 7 LBS
7. CONNECTOR TYPE M83723/95G084N OR EQUIVALENT APPROVED WOODWARD PRODUCT SUPPORT ENGINEER PRIOR TO MANUFACTURE
8. TOLERANCE ON MASTER KEY LOCATION TO BE ±10°.
9. CABLE ID TAGS SHALL BE BLACK FLEXIBLE HEATSHRINK SLEEVE PRINT SHALL BE PERMANENT MARKING WITH WHITE 0.12-INCH-H CHARACTERS ALIGNED WITH THE DIRECTION OF THE CABLE.

267-072
9971-1281, 5450-1345
7/2015

Figure 3-8. Cable, Stem Shaft Resolver, Feedback Signal

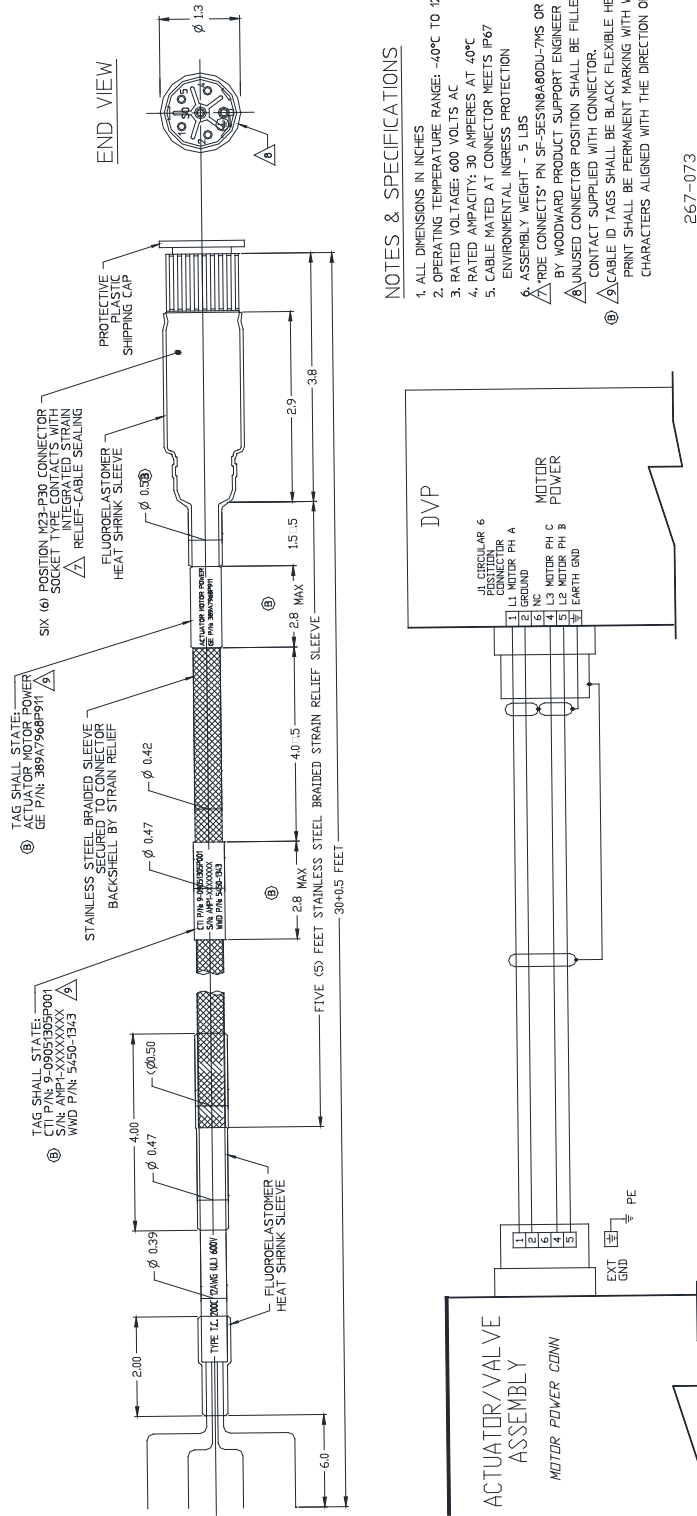

Figure 3-9. Cable, Motor Power

Chapter 4.

Maintenance and Hardware Replacement

Maintenance

The only maintenance required for the Large Electric Sonic Valve is lubricating the ball screw and bearing and inspecting the fuel overboard vent port every 12 months, in accordance with the descriptions below.

The LESV is not designed with field-replaceable components. Contact the turbine manufacturer (primary contact) or Woodward (secondary contact) for assistance in the event there is a problem requiring service or replacement.

Hardware Replacement

WARNING

EXPLOSION HAZARD—Substitution of components may impair suitability for Class I, Division 2 or Zone 2.

WARNING

To prevent possible serious personal injury, or damage to equipment, be sure all electric power, hydraulic pressure, and gas pressure have been removed from the valve and actuator before beginning any maintenance or repairs.

WARNING

Lift or handle the valve only by using the eyebolts.

WARNING

Due to typical noise levels in turbine environments, hearing protection should be worn when working on or around the Large Electric Sonic Valve. Noise levels of greater than 90 dB are possible.

WARNING

The surface of this product can become hot enough or cold enough to be a hazard. Use protective gear for product handling in these circumstances. Temperature ratings are included in the specification section of this manual.

WARNING

The LESV contains a mechanical spring under load. Do not disassemble, as this spring can cause bodily harm.

NOTICE

Use only Woodward-approved grease to lubricate the ball screw and bearing in this actuator. Use of any other grease will reduce performance and reliability. Woodward lubrication kits are available as part number 8923-1186.

Ball Screw Lubrication Procedure



WARNING

Wear rubber gloves in order to avoid contact with the grease during the lubrication procedure.

Lubricating the Ball Screw Assembly

1. Clean the outside of the actuator to ensure that no debris gets inside the actuator during the lubrication process. Any debris on the ball screw will reduce its life.
2. Remove the ball screw access plug located on the top of the gear cover with a 5/16 inch hex wrench (Figure 4-1).
3. Remove the ball screw port plug with a 3/16 inch hex wrench (Figure 4-2).
4. Set the ball screw access and port plugs aside and keep clean, ensuring that they are not scratched or marred.
5. Attach the thread connector of the grease syringe to the threaded grease port of the ball screw. The fitting should be fully seated (Figure 4-3).
6. Inject 2 cm³ of Woodward approved grease (8923-1186) into the ball screw grease port.
7. Remove the grease syringe from the ball screw grease port and install the ball screw port plug. Do not torque the port plug (Figure 4-4).
8. Remove the plug that is adjacent to the ball screw port, set aside, and keep clean, ensuring that the plug is not scratched or marred (Figure 4-5).
9. Using a permanent marker or tape, mark a 5/32 inch Allen wrench at 2.75 inches from the bottom. Make sure the top of the marking is at 2.75 inches (Figure 4-6).
10. Insert the Allen wrench into the port located adjacent to the ball screw port. The Allen wrench is seated if the marking is below the top surface of the gear cover (Figure 4-7).
11. If the Allen wrench is not seated, rotate the gears using a 3/16 inch hex wrench on the ball screw port plug and rotate clockwise until the 5/32 inch Allen wrench is seated.
12. Once the 5/32 inch Allen wrench is seated, torque the ball screw port plug to 38–42 lb.-in (4.3–4.7 Nm) (Figure 4-8).
13. Remove the 5/32 inch Allen wrench from the port, install the plug into the port located adjacent to the ball screw port, and torque to 38–42 lb.-in (4.3–4.7 Nm) (Figure 4-9).
14. Install the ball screw access plug and torque to 145–155 lb.-in (16.4–17.5 Nm) (Figure 4-10).



Figure 4-1.



Figure 4-2.

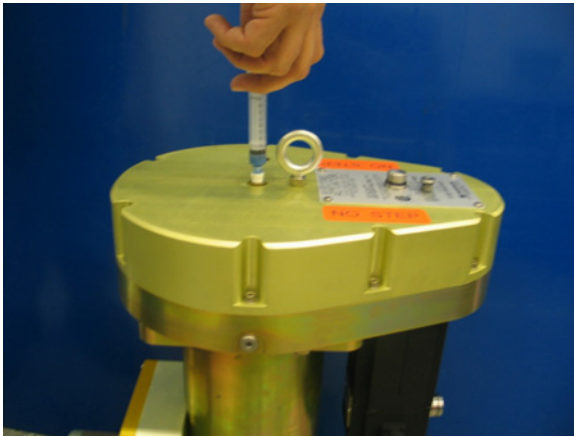

Figure 4-3.



Figure 4-4.



Figure 4-5.



Figure 4-6.

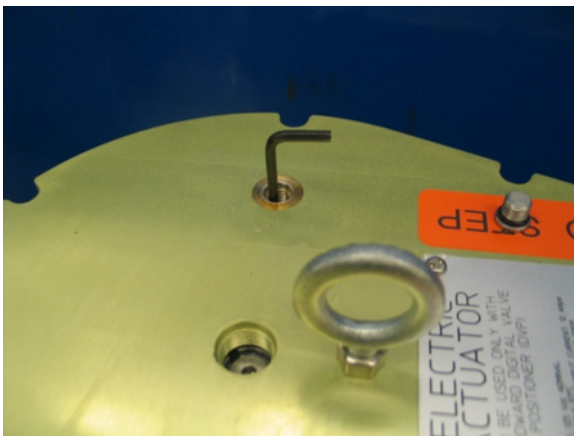

Figure 4-7.



Figure 4-8.

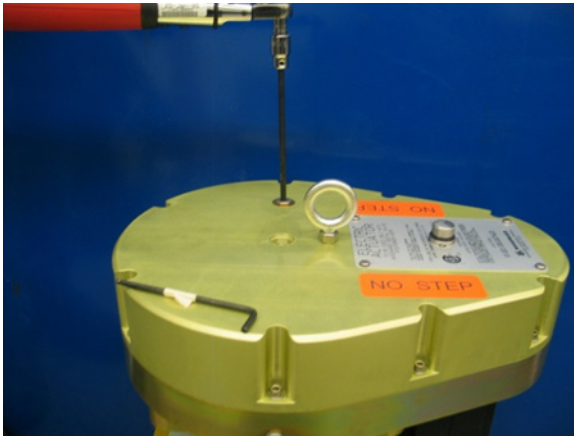

Figure 4-9.



Figure 4-10.

Bearing Lubrication Procedure

Lubricating the Bearing Assembly

1. Clean the outside of the actuator to ensure that no debris gets inside the actuator during the lubrication process. Any debris in the bearing will reduce its life.
2. Remove the bearing port plug with a 3/16 inch hex wrench (Figure 4-11).
Note: Some actuator models have bearing port plugs on both sides of the gearbox housing to allow for access from either side. For these models, the following greasing procedure only needs to be performed on one grease port. Leave the plug installed in the other port that is not being greased.
3. Set the plug aside and keep clean, ensuring that the inside plug surface is not scratched or marred.
4. Attach the thread connector of the grease syringe to the threaded bearing grease port. The fitting should be fully seated (Figure 4-12).
5. Inject 2 cm³ of Woodward approved grease (8923-1186) into the bearing grease port.
6. Remove the grease syringe from the bearing port and install the bearing port plug. Torque to 38–42 lb.-in (4.3–4.7 Nm) (Figure 4-13).

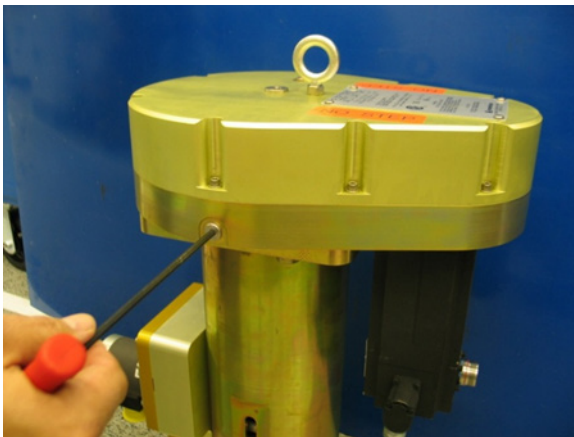

Figure 4-11.



Figure 4-12.

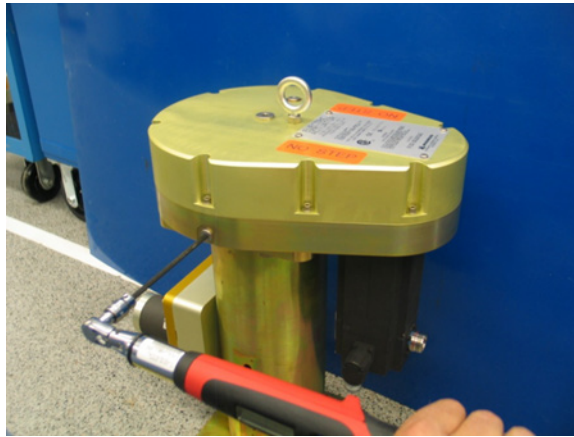

Figure 4-13.

Fuel Overboard Vent Port

There is a fuel overboard vent port that must be vented to a safe location. In normal operation, this vent should have very low leakage. However, if excessive leakage is detected from this vent port, contact a Woodward representative for assistance.

NOTICE

Never plug the fuel overboard vent port, which could cause the valve to malfunction or to operate improperly.

Fuel Overboard Vent Port Annual Inspections

Pressurize the valve section of the assembly to the rated pressure of 344.7 kPa (50 psig) and perform the following inspections:

- Inspect external sealing surfaces for leakage using leak detect fluid (no leakage is permitted). These locations include the inlet and discharge flange connections, as well as the pilot sleeve/valve body interface.
- Inspect for excessive overboard vent leakage (100 cm³/min maximum / 6.1 in³/min) from the Fuel Overboard Vent Port.

Chapter 5. Troubleshooting

Faults in the fuel control or governing system are often associated with speed variations of the prime mover, but such speed variations do not always indicate fuel control or governing system faults. Therefore, when improper speed variations occur, check all components, including the engine or turbine, for proper operation. Refer to the applicable electronic control manuals for assistance in isolating the trouble. The following steps describe troubleshooting for the gas fuel control valve.

Disassembly of the Large Electric Sonic Valve in the field is not recommended due to the dangerous forces contained in the springs. Under unusual circumstances, where disassembly becomes necessary, all work and adjustments should be made by personnel thoroughly trained in the proper procedures. When inspecting the valve for suspected blockages, remove the valve from the fuel system and only inspect with the unit powered off.

WARNING

The LESV contains a mechanical spring under load. Do not disassemble, as this spring can cause bodily harm.

WARNING

When inspecting the valve internally through the flanges for potential blockages, remove the valve from the fuel system and ensure that all power and electrical cables are disconnected. Never place hands inside the valve without ensuring that power is disconnected and the position indicator shows the valve is at the closed position.

WARNING

Do not operate the valve without proper support for the diverging sleeve. The diverging sleeve can only be properly supported by bolting and by properly torquing the outlet flange to either piping or an equivalent flange. Do not place hands inside the valve body during inspection, cleaning, or operation.

Note: When requesting information or service help from Woodward, it is important to include the part number and serial number of the valve assembly in your communication.

Table 5-1. Troubleshooting Symptom, Cause, and Remedy

Symptom	Possible Causes	Remedies
Valve will not open because the DVP will not reset	Motor wires not properly connected between DVP and actuator	Conduct continuity check.
	Resolver wires not properly connected between DVP and actuator	Conduct continuity check.
DVP will reset but valve will not open	Resolver sine wires high and low are flipped	Conduct continuity check.
	Resolver cosine wires high and low are flipped	Conduct continuity check.
	Resolver sine and cosine wires are swapped	Conduct continuity check.

Table 5-1. Troubleshooting Symptom, Cause, and Remedy (cont'd.)

Symptom	Possible Causes	Remedies
Upon enabling, valve will open and then fail closed	Resolver sine and cosine wires are swapped, and sine wires high and low are flipped	Conduct continuity check.
	Resolver sine and cosine wires are swapped, and cosine wires high and low are flipped	Conduct continuity check.
Poor flow accuracy	Characterization data in engine control does not match the valve	Verify characterization data matches the valve serial number.
	Build-up of contamination on the seat	Remove valve and inspect flow elements.
Poor position stability	One motor wire disconnected	Conduct continuity check.
Valve stem resolver indicates position error	Incorrect parameter file loaded	Verify the parameter file matches the valve serial number.
	Valve stem resolver wires not properly connected between DVP and actuator	Contact manufacturer for instructions or return to manufacturer for repair.
	Faulty resolver	Return to manufacturer or contact Turbine AISF in your region for repair.
	Drive train failure	Return to manufacturer or contact Turbine AISF in your region for repair.
High overboard vent leakage	Internal seals damaged	Return to manufacturer for repair or contact Turbine AISF in your regions or Woodward to get the proper service KIT number.
High seat leakage	Damage to valve seat or plug	Remove valve and inspect flow elements. Return to manufacturer for repair or contact Turbine AISF in your regions or Woodward to get the proper service KIT number.
	Contamination buildup in seat or plug	Remove valve and inspect flow elements. Return to manufacturer for repair or contact Turbine AISF in your regions or Woodward to get the proper service KIT number.
	Valve not fully closed	Remove valve and verify plug is not properly seated. Return to manufacturer for repair or contact Turbine AISF in your regions or Woodward to get the proper service KIT number.
External gas fuel leakage	Piping flange gaskets missing or deteriorated	Replace gaskets.
	Piping flanges improperly aligned	Rework piping as needed to achieve alignment requirements detailed in Chapter 3.
	Piping flange bolts improperly torqued	Rework bolts as needed to achieve torque requirements detailed in Chapter 3.
	Packing missing or deteriorated	Return actuator to Woodward for service.

Chapter 6.

Product Support and Service Options

Product Support Options

If you are experiencing problems with the installation, or unsatisfactory performance of a Woodward product, the following options are available:

- Consult the troubleshooting guide in the manual.
- Contact the manufacturer or packager of your system.
- Contact the Woodward Full Service Distributor serving your area.
- Contact Woodward technical assistance (see “How to Contact Woodward” later in this chapter) and discuss your problem. In many cases, your problem can be resolved over the phone. If not, you can select which course of action to pursue based on the available services listed in this chapter.

OEM or Packager Support: Many Woodward controls and control devices are installed into the equipment system and programmed by an Original Equipment Manufacturer (OEM) or Equipment Packager at their factory. In some cases, the programming is password-protected by the OEM or packager, and they are the best source for product service and support. Warranty service for Woodward products shipped with an equipment system should also be handled through the OEM or Packager. Please review your equipment system documentation for details.

Woodward Business Partner Support: Woodward works with and supports a global network of independent business partners whose mission is to serve the users of Woodward controls, as described here:

- A **Full Service Distributor** has the primary responsibility for sales, service, system integration solutions, technical desk support, and aftermarket marketing of standard Woodward products within a specific geographic area and market segment.
- An **Authorized Independent Service Facility (AISF)** provides authorized service that includes repairs, repair parts, and warranty service on Woodward's behalf. Service (not new unit sales) is an AISF's primary mission.

A current list of Woodward Business Partners is available at:

<https://www.woodward.com/en/support/industrial/service-and-spare-parts/find-a-local-partner>

Product Service Options

The following factory options for servicing Woodward products are available through your local Full-Service Distributor or the OEM or Packager of the equipment system, based on the standard Woodward Product and Service Warranty (Woodward North American Terms and Conditions of Sale 5-09-0690) that is in effect at the time the product is originally shipped from Woodward or a service is performed:

- Replacement/Exchange (24-hour service)
- Flat Rate Repair
- Flat Rate Remanufacture

Replacement/Exchange: Replacement/Exchange is a premium program designed for the user who is in need of immediate service. It allows you to request and receive a like-new replacement unit in minimum time (usually within 24 hours of the request), providing a suitable unit is available at the time of the request, thereby minimizing costly downtime. This is a flat-rate program and includes the full standard Woodward product warranty (Woodward North American Terms and Conditions of Sale 5-09-0690).

This option allows you to call your Full-Service Distributor in the event of an unexpected outage, or in advance of a scheduled outage, to request a replacement control unit. If the unit is available at the time of the call, it can usually be shipped out within 24 hours. You replace your field control unit with the like-new replacement and return the field unit to the Full-Service Distributor.

Charges for the Replacement/Exchange service are based on a flat rate plus shipping expenses. You are invoiced the flat rate replacement/exchange charge plus a core charge at the time the replacement unit is shipped. If the core (field unit) is returned within 60 days, a credit for the core charge will be issued.

Flat Rate Repair: Flat Rate Repair is available for the majority of standard products in the field. This program offers you repair service for your products with the advantage of knowing in advance what the cost will be. All repair work carries the standard Woodward service warranty (Woodward North American Terms and Conditions of Sale 5-09-0690) on replaced parts and labor.

Flat Rate Remanufacture: Flat Rate Remanufacture is very similar to the Flat Rate Repair option with the exception that the unit will be returned to you in "like-new" condition and carry with it the full standard Woodward product warranty (Woodward North American Terms and Conditions of Sale 5-09-0690). This option is applicable to mechanical products only.

Returning Equipment for Repair

If a control (or any part of an electronic control) is to be returned for repair, please contact your Full-Service Distributor in advance to obtain Return Authorization and shipping instructions.

When shipping the item(s), attach a tag with the following information:

- Return authorization number
- Name and location where the control is installed
- Name and phone number of contact person
- Complete Woodward part number(s) and serial number(s)
- Description of the problem
- Instructions describing the desired type of repair

Packing a Control

Use the following materials when returning a complete control:

- Protective caps on any connectors
- Antistatic protective bags on all electronic modules
- Packing materials that will not damage the surface of the unit
- At least 100 mm (4 inches) of tightly packed, industry-approved packing material
- A packing carton with double walls
- A strong tape around the outside of the carton for increased strength

NOTICE

To prevent damage to electronic components caused by improper handling, read and observe the precautions in Woodward manual 82715, *Guide for Handling and Protection of Electronic Controls, Printed Circuit Boards, and Modules*.

Replacement Parts

When ordering replacement parts for controls, include the following information:

- The part number(s) (XXXX-XXXX) that is on the enclosure nameplate
- The unit serial number, which is also on the nameplate

Engineering Services

Woodward offers various Engineering Services for our products. For these services, you can contact us by telephone, by email, or through the Woodward website.

- Technical Support
- Product Training
- Field Service

Technical Support is available from your equipment system supplier, your local Full-Service Distributor, or from many of Woodward's worldwide locations, depending upon the product and application. This service can assist you with technical questions or problem solving during the normal business hours of the Woodward location you contact. Emergency assistance is also available during non-business hours by phoning Woodward and stating the urgency of your problem.

Product Training is available as standard classes at many of our worldwide locations. We also offer customized classes, which can be tailored to your needs and can be held at one of our locations or at your site. This training, conducted by experienced personnel, will assure that you will be able to maintain system reliability and availability.

Field Service engineering on-site support is available, depending on the product and location, from many of our worldwide locations or from one of our Full-Service Distributors. The field engineers are experienced both on Woodward products as well as on much of the non-Woodward equipment with which our products interface.

For information on these services, please contact one of the Full-Service Distributors listed at:

<https://www.woodward.com/en/support/industrial/service-and-spare-parts/find-a-local-partner>

Contacting Woodward's Support Organization

For the name of your nearest Woodward Full-Service Distributor or service facility, please consult our worldwide directory at <https://www.woodward.com/support>, which also contains the most current product support and contact information.

You can also contact the Woodward Customer Service Department at one of the following Woodward facilities to obtain the address and phone number of the nearest facility at which you can receive information and service.

Products Used in Electrical Power Systems	
Facility	Phone Number
Brazil	+55 (19) 3708 4800
China	+86 (512) 8818 5515
Germany	+49 (711) 78954-510
India	+91 (124) 4399500
Japan	+81 (43) 213-2191
Korea	+82 (51) 636-7080
Poland	+48 (12) 295 13 00
United States	+1 (970) 482-5811

Products Used in Engine Systems	
Facility	Phone Number
Brazil	+55 (19) 3708 4800
China	+86 (512) 8818 5515
Germany	+49 (711) 78954-510
India	+91 (124) 4399500
Japan	+81 (43) 213-2191
Korea	+82 (51) 636-7080
United States	+1 (970) 482-5811

Products Used in Industrial Turbomachinery Systems	
Facility	Phone Number
Brazil	+55 (19) 3708 4800
China	+86 (512) 8818 5515
India	+91 (124) 4399500
Japan	+81 (43) 213-2191
Korea	+ 82 (51) 636-7080
Poland	+48 (12) 295 13 00
United States	+1 (970) 482-5811

Technical Assistance

If you need to contact technical assistance, you will need to provide the following information. Please write it down here before contacting the Engine OEM, the Packager, a Woodward Business Partner, or the Woodward factory:

General

Your Name _____

Site Location _____

Phone Number _____

Fax Number _____

Prime Mover Information

Manufacturer _____

Turbine Model Number _____

Type of Fuel (gas, steam, etc.) _____

Power Output Rating _____

Application (power generation, marine,
etc.) _____

Control/Governor Information

Control/Governor #1

Woodward Part Number & Rev. Letter _____

Control Description or Governor Type _____

Serial Number _____

Control/Governor #2

Woodward Part Number & Rev. Letter _____

Control Description or Governor Type _____

Serial Number _____

Control/Governor #3

Woodward Part Number & Rev. Letter _____

Control Description or Governor Type _____

Serial Number _____

Symptoms

Description _____

If you have an electronic or programmable control, please have the adjustment setting positions or the menu settings written down and with you at the time of the call.

Revision History

Changes in Revision J—

- Edited ATEX Directive and IECEx (LELA Actuator) compliance from nA to ec.
- Updated DoC

Changes in Revision H—

- Replaced EU DoC

Changes in Revision G—

- Added recommendations on corrosive fuels in Chapter 1

Revision F—

- Added Caution statement regarding cable separation under Electrical Connections in Chapter 3

Revision E—

- Removed CE line from Pressure Equipment Directive
- Updated EU DoC
- Updated DoI

Revision D—

- Replaced file tag in Figures 1-2a and 1-2b to eliminate confusion

Revision C—

- The following updates to the Regulatory Compliance Section
 - PED, ATEX (European), ATEX (Other European), and IECEx
 - Added RoHS Directive
- Added Max Fluid Temperature @ Discharge Flange and Seat Leakage to Table 1-1
- Replaced DoC 00371-04-EU-02-02

Revision B—

- Replaced warning box in Chapter 3
- Added Figures 3-1, 3-2, and 3-3 as examples to illustrate the warning on Bench Testing

Revision A—

- New ATEX Directive content in the Regulatory Compliance Section
- New DoI
- Updated drawings for Figures 1-1a, 1-1b, 1-2a, 1-2b, 1-3a, and 1-3b
- Added Piping load paragraph and Table 3-1 into the Piping Installation section of Chapter 3
- Added new content regarding cable connectors to the Electrical Connections section of Chapter 3
- Added note to step 2 of the Bearing Lubrication Procedure in Chapter 4

Declarations

EU DECLARATION OF CONFORMITY

EU DoC No.: 00371-04-EU-02-02
Manufacturer's Name: WOODWARD INC.
Manufacturer's Contact Address: 1041 Woodward Way
 Fort Collins, CO 80524 USA
Model Name(s)/Number(s): Large Electric Sonic Valve with LELA Actuator
 ASME B16.34 Class 300 and 600 flanges
 LESV: 2, 3, 4 and 6 inch diameters
 LESV II: 2 inch diameter
The object of the declaration described above is in conformity with the following relevant Union harmonization legislation: **LELA Actuator portion of LESV:**
 Directive 2014/34/EU of the European Parliament and of the Council of 26 February 2014 on the harmonization of the laws of the Member States relating to equipment and protective systems intended for use in potentially explosive atmospheres
Valve portion of LESV:
 Directive 2014/68/EU of the European Parliament and of the Council of 15 May 2014 on the harmonization of the laws of the Member States relating to the making available on the market of pressure equipment
 2", 3", 4": PED Category II
 6": PED Category III
For models with ID Module or Position Sensor:
 Directive 2014/30/EU of the European Parliament and of the Council of 26 February 2014 on the harmonization of the laws of the Member States relating to electromagnetic compatibility (EMC)
Markings in addition to CE marking:  II 3 G, Ex ec IIC T3 Gc
Applicable Standards:
PED: ASME Boiler and Pressure Vessel Code VIII, Div. 2, 2010
ATEX: EN IEC 60079-0: 2018 Explosive Atmospheres - Part 0: Equipment – General Requirements
 EN 60079-7:2015/A1: 2018 - Explosive Atmospheres – Part 7: Equipment protection by increased safety "e"
EMC: EN 61000-6-4:2007/A1:2011 - Electromagnetic compatibility (EMC) - Part 6-4: Generic Standards – Emissions for Industrial Environments
 EN 61000-6-2:2005 - Electromagnetic compatibility (EMC) - Part 6-2: Generic Standards – Immunity for Industrial Environments
Conformity Assessment: PED Module H – Full Quality Assurance
 CE-0062-PED-H-WDI 001-25-USA-rev-A Bureau Veritas SAS (0062)
 4 Place des Saisons, 92400 COURBEVOIE, FRANCE

This declaration of conformity is issued under the sole responsibility of the manufacturer
 We, the undersigned, hereby declare that the equipment specified above conforms to the above Directive(s).

MANUFACTURER

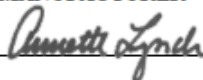

Signature
 Annette Lynch

Full Name
 Engineering Manager

Position
 Woodward, Fort Collins, CO, USA

Place
 31 October 2025

Date

5-09-1183 Rev 43

DECLARATION OF INCORPORATION Of Partly Completed Machinery 2006/42/EC
--

File name: 00371-04-EU-02-01
Manufacturer's Name: WOODWARD INC.

Contact Address: 1041 Woodward Way
 Fort Collins, CO 80524 USA

Model Names: Large Electric Sonic Valve (LESV, LESV II)
 Sizes 2", 3", 4", and 6", Class 300 and 600

This product complies, where applicable, with the following Essential Requirements of Annex I: 1.1, 1.2, 1.3, 1.4, 1.5, 1.6, 1.7

The relevant technical documentation is compiled in accordance with part B of Annex VII. Woodward shall transmit relevant information if required by a reasoned request by the national authorities. The method of transmittal shall be agreed upon by the applicable parties.

The person authorized to compile the technical documentation:

Name: Dominik Kania, Managing Director
Address: Woodward Poland Sp. z o.o., ul. Skarbowa 32, 32-005 Niepolomice, Poland

This product must not be put into service until the final machinery into which it is to be incorporated has been declared in conformity with the provisions of this Directive, where appropriate.

The undersigned hereby declares, on behalf of Woodward Inc. of Loveland and Fort Collins, Colorado that the above referenced product is in conformity with Directive 2006/42/EC as partly completed machinery:

MANUFACTURER

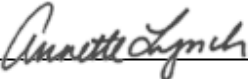
Signature	
Full Name	Annette Lynch
Position	Engineering Manager
Place	Woodward Inc., Fort Collins, CO, USA
Date	August 20, 2021

Document: 5-09-1182 (rev. 18)

This Page Intentionally Left Blank

We appreciate your comments about the content of our publications.

Send comments to: industrial.support@woodward.com

Please reference publication **35045**.



PO Box 1519, Fort Collins CO 80522-1519, USA
1041 Woodward Way, Fort Collins CO 80524, USA
Phone +1 (970) 482-5811

Email and Website—www.woodward.com

Woodward has company-owned plants, subsidiaries, and branches, as well as authorized distributors and other authorized service and sales facilities throughout the world. Complete address / phone / fax / email information for all locations is available on our website.