



**PSG Governor
with Aluminum Case**

Installation and Operation Manual

IMPORTANT



This is the safety alert symbol. It is used to alert you to potential personal injury hazards. Obey all safety messages that follow this symbol to avoid possible injury or death.

DEFINITIONS

- **DANGER**—Indicates a hazardous situation which, if not avoided, will result in death or serious injury.
- **WARNING**—Indicates a hazardous situation which, if not avoided, could result in death or serious injury.
- **CAUTION**—Indicates a hazardous situation which, if not avoided, could result in minor or moderate injury.
- **NOTICE**—Indicates a hazard that could result in property damage only (including damage to the control).
- **IMPORTANT**—Designates an operating tip or maintenance suggestion.

WARNING

The engine, turbine, or other type of prime mover should be equipped with an overspeed shutdown device to protect against runaway or damage to the prime mover with possible personal injury, loss of life, or property damage.

The overspeed shutdown device must be totally independent of the prime mover control system. An overtemperature or overpressure shutdown device may also be needed for safety, as appropriate.



Read this entire manual and all other publications pertaining to the work to be performed before installing, operating, or servicing this equipment. Practice all plant and safety instructions and precautions. Failure to follow instructions can cause personal injury and/or property damage.



This publication may have been revised or updated since this copy was produced. To verify that you have the latest revision, be sure to check the *publications page* on the Woodward website:

www.woodward.com/publications

The current revision and distribution restriction of all publications are shown in manual **26311**.

The latest version of most publications is available on the *publications page*. If your publication is not there, please contact your customer service representative to get the latest copy.



Any unauthorized modifications to or use of this equipment outside its specified mechanical, electrical, or other operating limits may cause personal injury and/or property damage, including damage to the equipment. Any such unauthorized modifications: (i) constitute "misuse" and/or "negligence" within the meaning of the product warranty thereby excluding warranty coverage for any resulting damage, and (ii) invalidate product certifications or listings.

NOTICE

To prevent damage to a control system that uses an alternator or battery-charging device, make sure the charging device is turned off before disconnecting the battery from the system.

NOTICE

To prevent damage to electronic components caused by improper handling, read and observe the precautions in Woodward manual **82715**, *Guide for Handling and Protection of Electronic Controls, Printed Circuit Boards, and Modules*.

Woodward reserves the right to update any portion of this publication at any time. Information provided by Woodward is believed to be correct and reliable. However, no responsibility is assumed by Woodward unless otherwise expressly undertaken.

Contents

CHAPTER 1. GENERAL INFORMATION AND INSTALLATION	1
Introduction	1
References	1
Installation	1
Linkage	3
Oil Supply	4
Speed Adjustment	8
Speed Droop	8
External Shutdown Solenoid	8
Initial Operation and Adjustment	11
Storage	11
CHAPTER 2. PRINCIPLES OF OPERATION	14
Mechanical Hydraulic System	14
Ballhead System.....	14
Compensation System	14
Load Increase Example.....	15
Load Decrease Example	15
CHAPTER 3. MAINTENANCE	18
Introduction	18
Troubleshooting.....	18
Speed Droop Adjustment	24
Removal of Governor from Engine.....	24
Tools for Disassembly and Assembly	25
Disassembly of Governor	26
Parts Cleaning	30
Parts Check	30
Parts Repair.....	31
Assembly	31
Testing.....	46
CHAPTER 4. REPLACEMENT PARTS	47
Replacement Parts In Formation.....	47
Illustrated Parts Breakdown	47
CHAPTER 5. AUXILIARY EQUIPMENT	51
Introduction	51
Spring Driven-Oil Damped Ballhead	51
Torsion Spring	53
Pneumatic Speed Setting.....	54
Speed Adjusting Motor	63
Externally Adjusted Speed Droop	69
Internal Return Spring	72
Temperature Compensated Needle Valve	80
Fuel Rod	80
CHAPTER 6. PRODUCT SUPPORT AND SERVICE OPTIONS	86
Product Support Options	86
Product Service Options.....	86
Returning Equipment for Repair.....	87
Replacement Parts	87
Engineering Services.....	88
Contacting Woodward's Support Organization	88
Technical Assistance.....	89

Illustrations and Tables

Figure 1-1. External Features of Basic PSG with New Style Cover	2
Figure 1-2. External Features of Former Style Cover	2
Figure 1-3. Recommended Terminal Shaft Travel Adjustment	3
Figure 1-4. Non-Linear Linkage Arrangement	4
Figure 1-5. PSG Separate Sump Installation	5
Figure 1-6. Recommended Quick Starts	6
Figure 1-7. Primary Shutdown PSG Governor	9
Figure 1-8. Optional Shutdown Connection for the PSG Governor	9
Figure 1-9. PSG Separate Sump Installation	9
Figure 1-10. Recommended Engine Oil System	10
Figure 1-11. Governor Speed Versus Pump Flow	10
Figure 1-12. Outline Drawing, Basic PSG	12
Figure 1-13. Outline Drawing, PSG with New Style Cover	13
Figure 2-1. Cutaway Schematic, Basic PSG	16
Figure 2-2. Schematic Diagram, PSG with External Return Spring	17
Figure 3-1. Droop Adjustment	24
Figure 3-2. Assembly Tools	26
Figure 3-3. Terminal Shaft Removal	27
Figure 3-4. Speeder Spring Removal	28
Figure 3-5. Pilot Valve Disassembly	28
Figure 3-6. Removal of Ballhead	29
Figure 3-6A. Bushing Shift Check	31
Figure 3-7. Check Valve Assembly	32
Figure 3-8. Install Idler Gear Stud and Gear	33
Figure 3-9. Plugs Inserted for CCW Rotation	33
Figure 3-10. Plugs Inserted for CW Rotation	33
Figure 3-11. Pilot Valve Bushing Assembly	34
Figure 3-12. Compensating Bushing Assembly	34
Figure 3-13. Seating Retaining Ring	35
Figure 3-14. Base to Case Assembly	35
Figure 3-15. Buffer System Assembly	36
Figure 3-16. Power Piston Assembly	36
Figure 3-17. Ballhead Installation	37
Figure 3-18. Thrust Bearing and Speeder Spring Parts	38
Figure 3-19. Thrust Bearing and Spring Seat Assembly	38
Figure 3-20. Spring Seat Adjustment	39
Figure 3-21. Centering the Pilot Valve Plunger	39
Figure 3-22. Torquing Lock Nut	40
Figure 3-23. Centering Pilot Valve Plunger	40
Figure 3-24. Speeder Spring Installation	41
Figure 3-25. Terminal Lever & Terminal Shaft Parts Layout	41
Figure 3-26. Droop Bracket Assembly	42
Figure 3-27. Setting Zero Droop	42
Figure 3-28. Speed Adjusting Parts Layout	43
Figure 3-29. Speed Adjusting & Floating Lever Assembly	43
Figure 3-30. Bending Spring Wire Pin	44
Figure 3-31. Seal Installation	44
Figure 3-32. Welch Plug Installation	45
Figure 3-33. Final Assembly of Relief Valve, Needle Valve, & Cover	45
Figure 4-1a. Exploded View of PSG Governor (sheet 1 of 2)	49
Figure 4-1b. Exploded View of PSG Governor (sheet 2 of 2)	50

Illustrations and Tables

Figure 5-1. Cover Damage	52
Figure 5-2. Ballhead Assembly, Exploded	53
Figure 5-3. PSG with Pneumatic Head	54
Figure 5-4. Schematic Diagram, PSG with Pneumatic Speed Setting and External Return Spring	55
Figure 5-5. Schematic Diagram, PSG with Pneumatic Speed Setting & Horizontal Return Spring	56
Figure 5-6. Floating Lever Assembly	57
Figure 5-7. Schematic of Diaphragm & Bellofram on Pneumatic Speed Setting Assembly	57
Figure 5-8. Exploded View of PSG Sealed Pneumatic Speed Setting	59
Figure 5-9. Exploded View of PSG Unsealed Pneumatic Speed Setting	61
Figure 5-10. Outline Drawing, PSG with Pneumatic Speed Setting	62
Figure 5-11. Wiring Diagram for PM Motor	63
Figure 5-12. Wiring Diagram for Bodine Motor	64
Figure 5-13. Outline Drawing, PSG with Externally Adjusted Speed Droop and PM Speed Adjusting Motor	65
Figure 5-14. Outline Drawing, PSG with Externally Adjusted Speed Droop and Bodine Speed Adjusting Motor	66
Figure 5-15. Schematic Diagram, PSG with Horizontal Internal Return Spring, Externally Adjustable Droop, and Electric Speed Setting	67
Figure 5-16. PSG with Vertical Return Spring & Bodine Speed Setting Motor	68
Figure 5-17. PSG with Vertical Return Spring and PM Speed Setting Motor	68
Figure 5-18. PSG with Externally Adjusted Speed Droop	70
Figure 5-19. Right Hand External Droop Assembly	71
Figure 5-20. Left Hand External Droop Assembly	71
Figure 5-21. Sub Cap Removal	72
Figure 5-22. Exploded View, PSG with Horizontal Return Spring, Externally Adjusted Droop, Torsion Spring, and Bodine Motor	75
Figure 5-23. Exploded View, PSG Vertical Return Spring	77
Figure 5-24. Exploded View, PSG Vertical Return Spring Equipped with Electric Motor	79
Figure 5-25. Exploded View of PSG Fuel Rod	81
Figure 5-26. Exploded View of PSG Fuel Rod	82
Figure 5-27. Vertical Return Spring Cover and Installation Parts	83
Figure 5-28. Pittman PM Speed Adjusting Motor and Installation Parts	84
Figure 5-29. Outline Drawing, PSG with External Droop	85
Table 1-1. Oil Chart	7
Table 1-2. Viscosity Comparisons	7
Table 3-1. Troubleshooting	19
Table 3-2. Tool List	25
Table 3-3. Tools Required for Testing	46

Chapter 1.

General Information and Installation

Introduction

The basic PSG (Pressure Compensated Simple Governor) is a hydraulic speed governor with buffer type compensation. It is normally isochronous, that is, if the engine is not overloaded it maintains the same speed regardless of load, except momentarily at the time load change occurs.

The governor uses engine lubricating oil or an oil supply from a separate sump furnished by the engine manufacturer. If the latter is used, lift should not exceed 12 inches (30 cm), and a foot valve should be furnished.

IMPORTANT

The torque, work capacity, and maximum work values of the PSG governor are based on 25 psi (172 kPa) supply oil pressure to the governor. These values can vary depending on the supply oil pressure.

A new cover for the standard PSG governor is a vertical return-spring type cover. This cover is used with or without a return spring, and also, with or without a Pittman PM (Permanent Magnet) speed-setting motor. For PSG governors without a motor, the cover is furnished with a guide plug for the low-speed stop screw (see Figure 1-1).

References

04018	SG/PSG Speed Adjusting Motor Cover
25071	Oils for Hydraulic Controls
25805	Governor Test Stand 8909-051/053
37010	PSG Governor product specification
50007	Recommended Sizing of Drain Lines from Hydraulic Controls
50517	Recommended Engine Oil Supply System for Small Governors and Actuators

Installation

Place a gasket between the base of the governor and the engine mounting pad. The gasket must not block any holes in the governor base. Install the governor on the engine, taking particular care to mount it squarely on the engine.

Be sure that the drive connection is properly aligned. Connect the fuel control linkage for 2/3 travel from no-load with overtravel at both ends and check that fuel flow is completely closed off when the governor is in its no-fuel position. See Figure 1-3. Also check and ensure that maximum fuel flow is provided when the governor's terminal shaft is at its full load position (2/3 travel). The linkage must be free from friction and looseness.

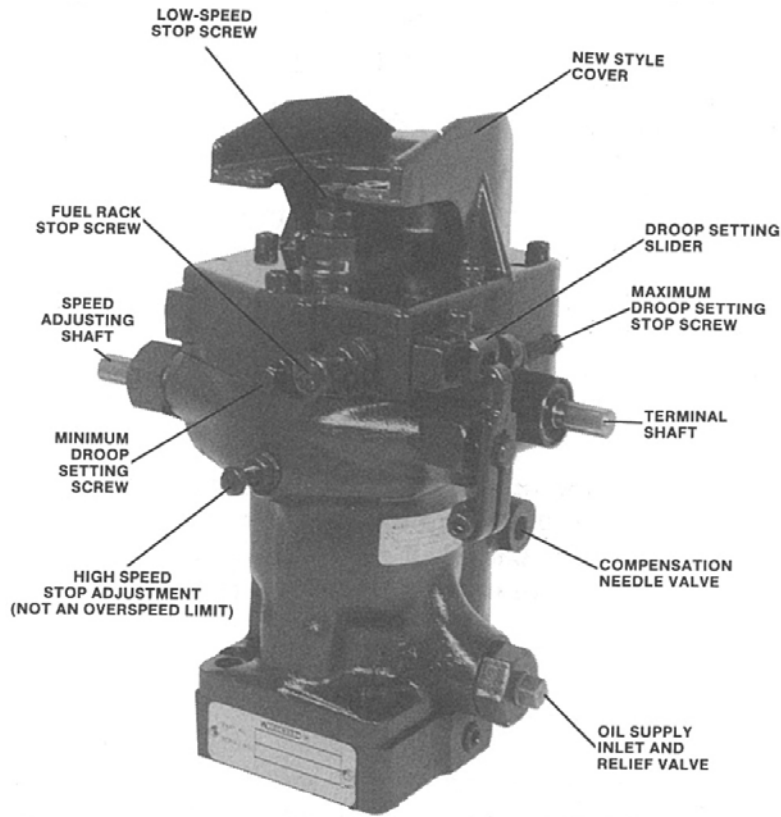

Figure 1-1. External Features of Basic PSG with New Style Cover

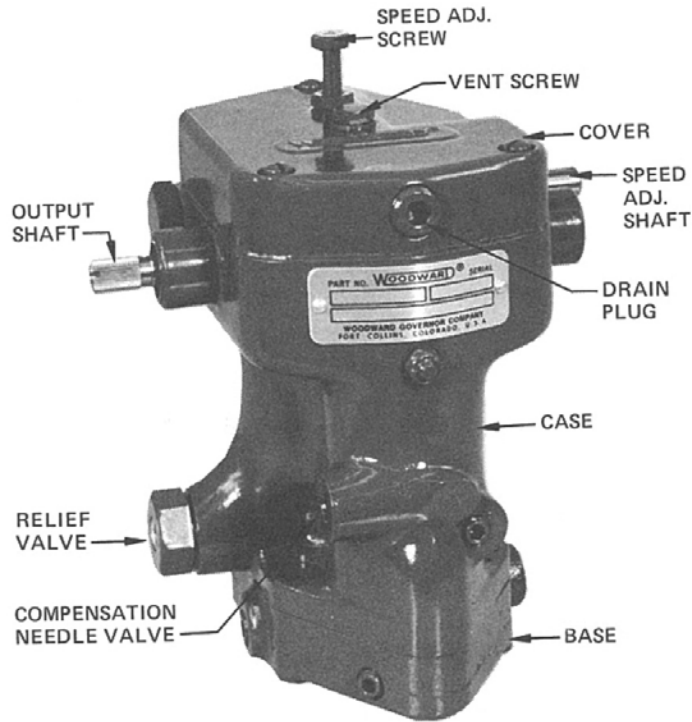

Figure 1-2. External Features of Former Style Cover

Linkage

Linear

Use a linear linkage for diesel engine applications. Adjust the fuel linkage to provide control of engine fuel from “MINIMUM PRIME MOVER STOP TO MAXIMUM PRIME MOVER STOP” within the limits of the governor output-shaft travel. We recommend using two-thirds or more output shaft travel between “PRIME MOVER NO LOAD POSITION” and FULL LOAD POSITION.” (See Figure 1-3.)

Attach the fuel rack linkage to the governor output shaft. Be sure there is no lost motion or binding in the linkage.



WARNING Be sure to allow sufficient overtravel at each end of terminal-shaft travel so the governor can shut down the engine and also give maximum fuel when required.



IMPORTANT The torque and work capacity values quoted are based on 25 psi (172 kPa) supply pressure to the governor. These values can vary, depending on the oil supply pressure.

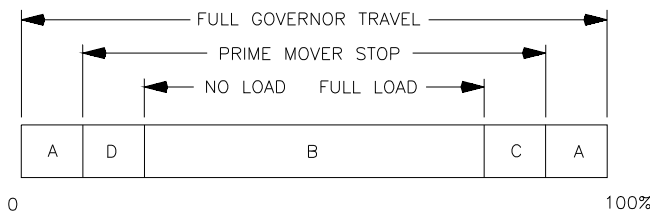

- A - OVERTRAVEL TO ENSURE PRIME MOVER STOPS ARE REACHED.
- B - NO LOAD TO FULL LOAD TRAVEL - NORMALLY 2/3 OF FULL GOVERNOR TRAVEL IS RECOMMENDED.
- C - TRAVEL REQUIRED TO ACCELERATE THE PRIME MOVER.
- D - TRAVEL REQUIRED TO DECELERATE OR SHUT DOWN THE PRIME MOVER.

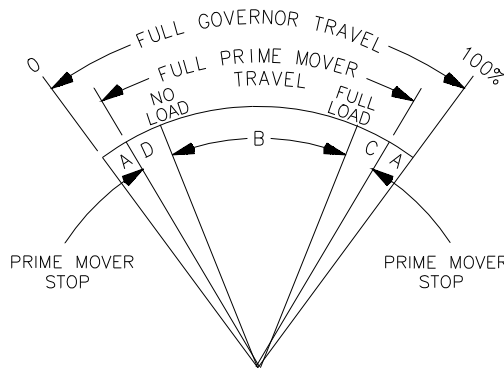

MAXIMUM WORK CAPACITY OVER FULL GOVERNOR TRAVEL OF 42" IS * . SEE ABOVE FOR RECOMMENDED GOVERNOR OUTPUT TRAVEL. IN SPECIAL APPLICATIONS MIN AND MAX PRIME MOVER STOPS MAY BE OUTSIDE THE GOVERNOR STOPS.

- * 14.4 IN-LB WITH 100 PSI OPERATING PRESSURE
- 33.6 IN-LB WITH 200 PSI OPERATING PRESSURE

MI-153F
04-6-3

Figure 1-3. Recommended Terminal Shaft Travel Adjustment

Non-Linear

Applications involving a butterfly valve, such as on a gas engine, require a non-linear linkage.

Figure 1-4 illustrates the relationship between governor output shaft and butterfly obtained with simple linkage of maximum non-linearity. When installing this linkage, make sure the two following conditions are attained when the linkage is in the no-load position:

1. The lever which is attached to the governor and the connecting link is in line with the governor output shaft and the point of attachment of the connecting link to the butterfly lever.
2. The butterfly lever must be at 90 degrees with the connecting link.

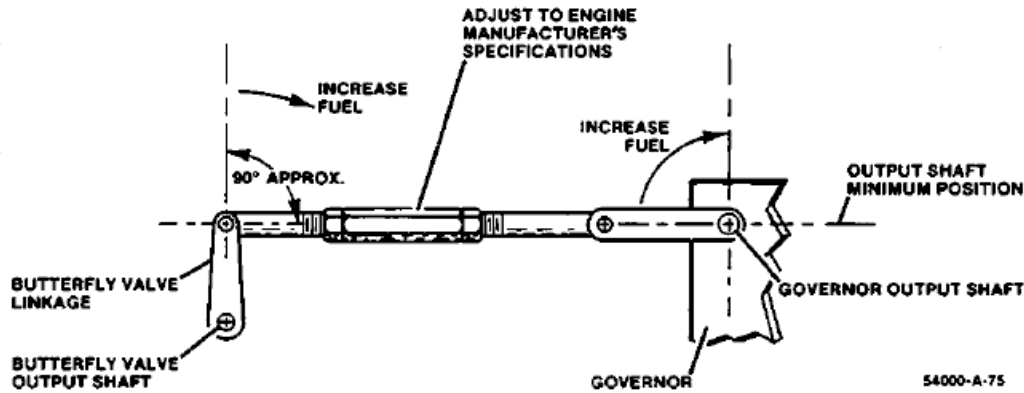

Figure 1-4. Non-Linear Linkage Arrangement

Refer to the prime-mover manufacturer's manual for the correct linkage selection and installation.

IMPORTANT

Governor rotation, either clockwise or counterclockwise, is determined by facing the top of the governor and viewing the direction the drive rotates.

Rotation of the governor drive shaft must be the same as that of the engine drive when looking down on the mounting pad.

Correct direction of rotation for the PSG governor is shown by a raised arrow at the bottom of the governor case on the side opposite to the oil supply inlet, when looking at the arrow from the top of the governor. See Chapter 3, Figures 3-7, 3-10, and 3-11 for more information on clockwise (cw) and counterclockwise (ccw) direction of rotation.

Oil Supply

The PSG is a single acting governor, that is, it utilizes oil pressure in one direction only and depends upon spring force to move the fuel control linkage in the fuel off direction. Some models incorporate a spring within the governor's cover, but most governors require an external spring which exerts a torque of 25 or 50 lb-in (2.8 or 5.6 N·m) on the terminal shaft in the return direction for a PSG governor with 100 or 200 psi (690 or 1379 kPa) operating pressure respectively.

Install a 3/8" (9.5 mm) oil line from the governor to either the engine lubricating oil pump pressure line, or a separate sump, unless the engine's mounting pad is drilled for an oil supply. Use a 40 μ m (nominal) filter with a minimum capacity of 2 US gal/min (7.6 L/min).

IMPORTANT

A permissible oil supply pressure range is a maximum of 12 inches (30 cm) suction lift from a separate sump (Figure 1-5) to a maximum of 75 psi (517 kPa) from the engine lube oil system. Torque and work values vary accordingly. Consult Woodward when supply pressures must exceed 75 psi (517 kPa).

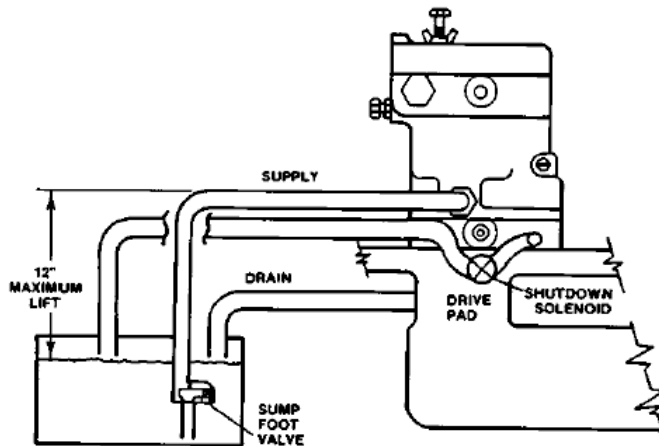

Figure 1-5. PSG Separate Sump Installation

Allow free drainage of oil from the governor pilot valve by providing adequate drain holes from the drive coupling (1/4" [6 mm] diameter or equivalent in multiple holes). Be sure the engine mounting pad gasket does not block off the three drain holes in the governor base. See Figures 1-12 and 1-13.

If the governor is mounted horizontally, the needle valve must be on the bottom. Horizontal mounting also requires that a 1/4" pipe tapped hole be provided in the upper part of the governor case and connected to the engine sump or to the separate sump with a 3/8" drain line. For connection of the drain on the new style cover when the governor is mounted horizontally, see Figure 1-13.

Use a supply system similar to Figure 1-6 for applications requiring quick starts. Note that the end of the overboard drain line must be kept above the engine sump oil level.

Minimum drainage or siphon level is that oil level in the governor below which the governor pump gears are no longer submerged in oil. Oil level in the oil tank must always be as high as, or higher than this line. If not, governor pump gears are no longer submerged in oil and will cavitate when the prime mover is started, causing possible loss of governor control.

Use the information given in Tables 1-1 and 1-2 as a guide in the selection of a suitable lubricating/ hydraulic oil. Oil grade selection is based on the operating temperature range of the governor. Also, use this information to aid in recognizing and correcting common problems associated with oil used in Woodward products.

For applications where the Woodward governor shares the oil supply with the engine, use the oil recommended by the engine manufacturer.

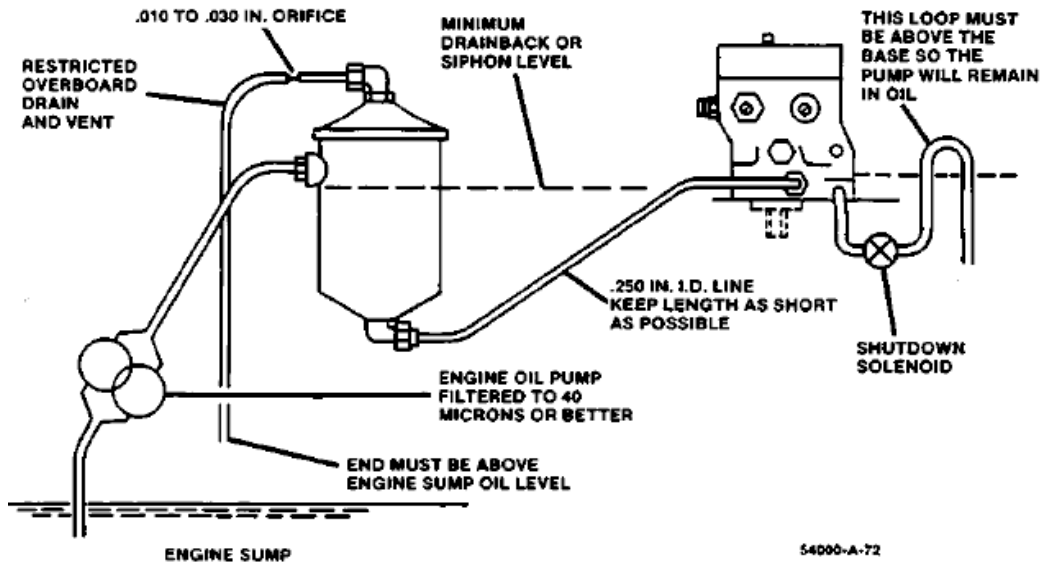

Figure 1-6. Recommended Quick Starts

Governor oil is both a lubricating oil and a hydraulic oil. It must have a viscosity index that allows it to perform over the operating temperature range and it must have the proper blending of additives that cause it to remain stable and predictable over this range.

Governor oil must be compatible with seal materials (nitrile, polyacrylic, and fluorocarbon). Many automotive and gas engine oils, industrial lubricating oils, and other oils of mineral or synthetic origin meet these requirements. Woodward governors are designed to give stable operation with most oils with the viscosity, at the operating temperature, between 50 and 3000 SUS (Saybolt Universal Seconds). At the normal operating temperature, the viscosity should be between 100 to 300 SUS. Poor actuator response or instability may be an indication that the oil viscosity is outside this range.

Excessive component wear or seizure in a governor indicates the possibility of:

- Insufficient lubrication caused by:
 - a. An oil that flows slowly when it is cold especially during start-up.
 - b. An oil line with restrictions caused by either obstructions within or bends in the line (for external supply governors only).
 - c. No oil in the governor.
- Contaminated oil caused by:
 - a. Dirty oil containers.
 - b. A governor exposed to heating up and cooling down cycles, which creates condensation of water in the oil.



WARNING

A loss of stable governor control and possible engine overspeed may result if the viscosity exceeds the 50 to 3000 SUS range.

The recommended continuous operating temperature of the oils is 140 to 200 °F (60 to 93 °C). The ambient temperature limits are -20 to +200 °F (-30 to +93 °C). Measure the temperature of the governor on the outside lower part of the case. The actual oil temperature will be slightly warmer by approximately 10 °F (6 °C).

ANY OIL LISTED IS ONLY A SUGGESTION. USE THE OIL OF YOUR CHOICE WITH THE CORRECT VISCOSITY AS INDICATED IN THE CHART.

RECOMMENDED UPPER LIMIT OF PETROLEUM OIL IS 200°F
 RECOMMENDED UPPER LIMIT OF SYNTHETIC OIL IS 250°F

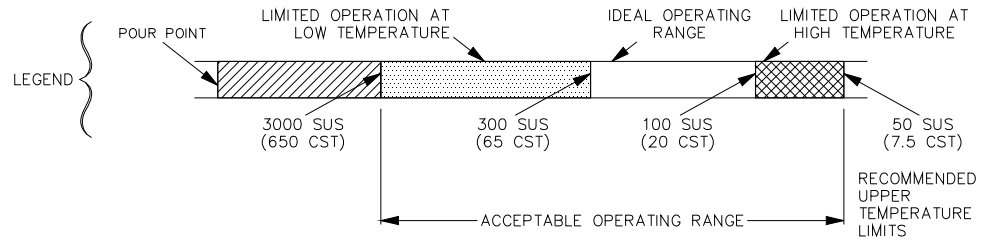
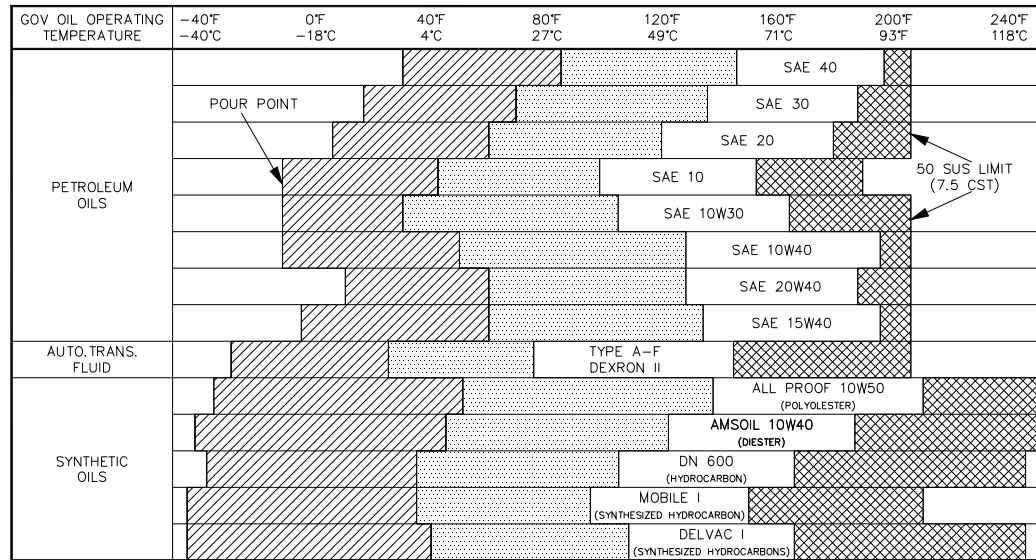

250-079

Table 1-1. Oil Chart

VISCOSITY COMPARISONS				
CENTISTOKES (CST, CS, OR CTS)	SAYBOLT UNIVERSAL SECONDS (SUS) NOMINAL AT 100 DEGREES F	SAE MOTOR (APPROXIMATE)	SAE GEAR (APPROXIMATE)	ISO
15	80	5W		15
22	106	5W		22
32	151	10W	75	32
46	214	10	75	46
68	310	20	80	68
100	463	30	80	100
150	696	40	85	150
220	1020	50	90	220
320	1483	60	115	320
460	2133	70	140	460

250-087
97-11-04 skw

Table 1-2. Viscosity Comparisons

Speed Adjustment

There are several types of speed adjustments available for the PSG. Some governors have a lever attached to the external end of the speed adjusting shaft. This lever is used in conjunction with the high and low speed stop screws. Utilizing a linkage arrangement with the lever provides a remote speed adjustment for the governor. The screw in the cover is used to set the minimum speed stop while the screw in the case controls the maximum speed stop of the governor.

The governor can also be equipped with either a pneumatic speed adjustment head or an electric motor for remote speed adjustment. The pneumatic speed adjustment head mounts on the cover as does the electric motor. Both pneumatic and electric speed adjustments utilize a high speed stop screw.

There are two types of electric motors available, see Chapter 5, Figures 5-13 and 5-14. Both drive the speed adjusting shaft through a worm and gear with a friction clutch to protect the motor if the adjustment is run against the stops.

Speed Droop

Speed droop is provided and can be internally or externally adjustable between zero and seven percent, depending on speed setting, speeder spring, flyweights, and terminal shaft travel. Speed droop permits load division between two or more engines driving generators in parallel or connected to a single shaft. If the engine is operated alone or on a dc system with proper generator compounding, the governor may be set for zero droop (isochronous operation).

IMPORTANT

If the governor output shaft does not use the full 2/3 of available travel from “NO LOAD” to “FULL LOAD,” droop will also be reduced proportionately.

For ac generating units tied in with other units, set the droop sufficiently high to prevent interchange of load between units. If one unit in the plant or system has enough capacity, set its governor on zero droop and it will regulate the frequency of the entire system. This unit then takes all load changes within the limits of its capacity and controls the frequency if its capacity is not exceeded.

All units may be run in droop, and the no load to full load speed change must be equal for all paralleled units. Speed will change as load is increased or decreased. Adjust speed setting to share load: increasing or decreasing speed setting on a particular unit will increase or decrease the load on that unit, respectively.

External Shutdown Solenoid

Since no governor-mounted shutdown devices are available for these small governors, it is common practice to apply external solenoids for shutdown. Basically these schemes drain the governor compensation or control oil to the prime mover lube oil sump. This information is intended to formalize some general guidelines for external shutdowns. Strict application of these guidelines may not be successful in every case as factors like governor condition and oil viscosity will affect results. Therefore, it is necessary for all systems to be thoroughly tested after installation.

Two factors are of primary importance in utilizing external solenoid shutdowns. First is the location of the solenoid. Figures 1-7 and 1-8 show the proper connections. Once a suitable connection is decided, the solenoid should be connected with tubing runs as short as possible. The solenoid should also be mounted below the governor and oriented so that it does not fill with air. Air trapped by the tubing causes governor instability. Figure 1-9 shows a separate sump arrangement and Figure 1-10 shows a typical installation using engine oil.

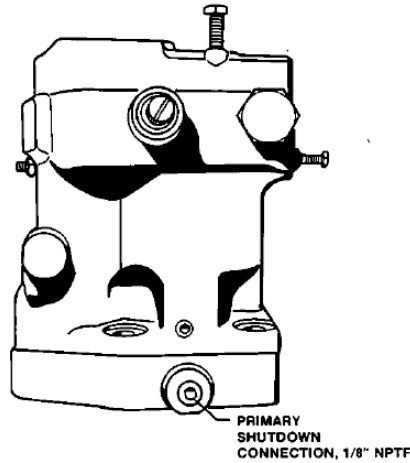

Figure 1-7. Primary Shutdown PSG Governor

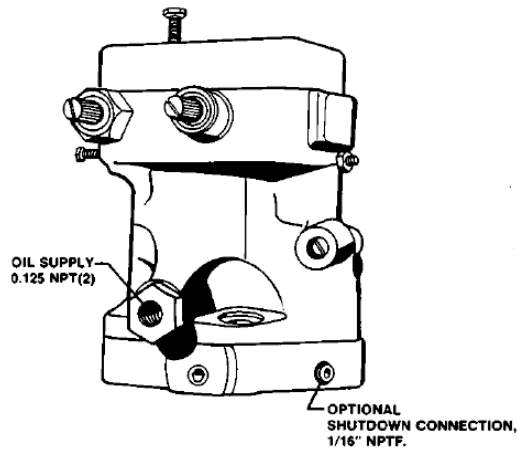

Figure 1-8. Optional Shutdown Connection for the PSG Governor

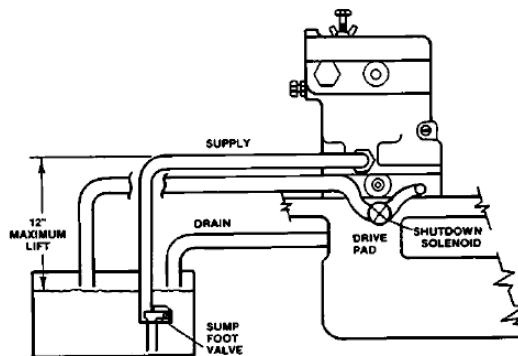

Figure 1-9. PSG Separate Sump Installation

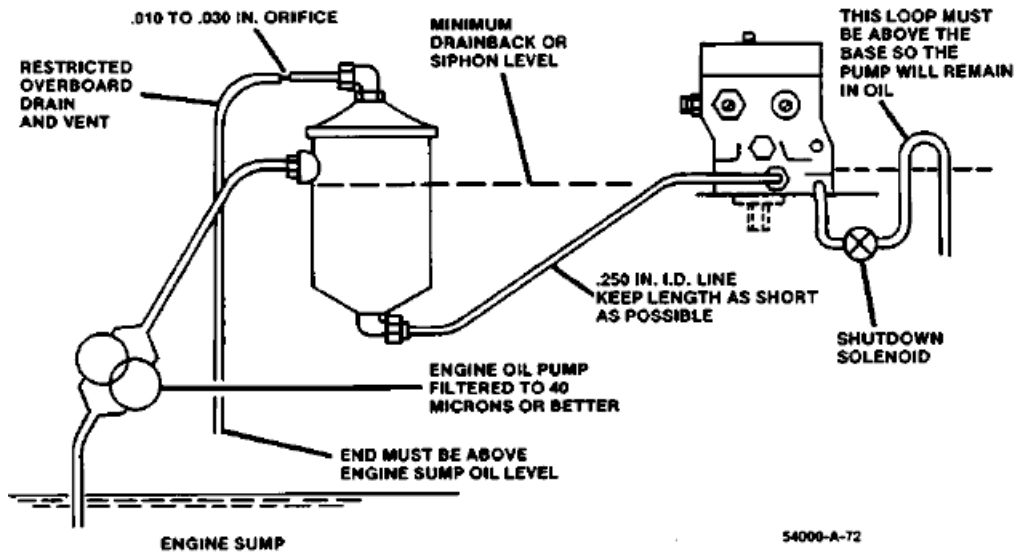

Figure 1-10. Recommended Engine Oil System

The second consideration is solenoid size. The solenoid and all connected tubing must pass enough flow to ensure that the governor moves to minimum position and remains there. For PSG governors the solenoid dumps oil directly from the power cylinder, and must handle the full pump output. Therefore, different flow capabilities are required depending on rated governor speed. Figure 1-11 shows PSG pump output versus governor speed.

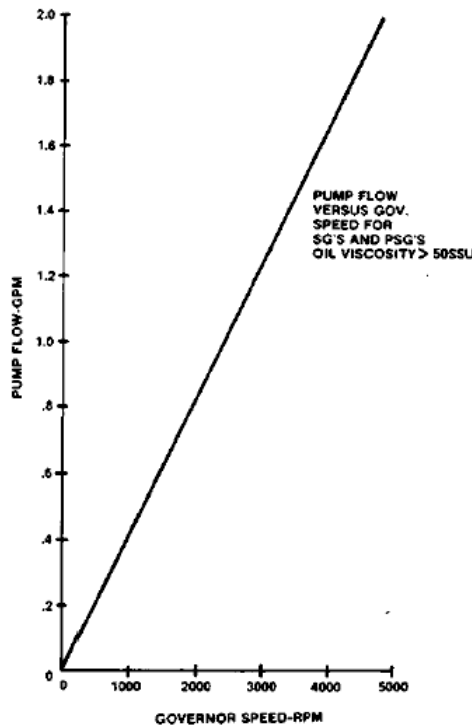

Figure 1-11. Governor Speed Versus Pump Flow

All pump output must be discharged with maximum pressure drop listed in the chart below.

Governor Type	Relief Valve Pressure Setting	
	PSG	75 psi (517 kPa)
	P 20 psi (138 kPa)	P 50 psi (345 kPa)

Initial Operation and Adjustment

Normally, the governor adjustments for speed, droop, and compensation needle valve are set at the factory. Minor adjustments are required after installation due to engine or turbine variances. Normal factory settings of the various governor adjustments are given in the table below.

Adjustment	Factory (Test) Setting
Speed Setting:	Preset at the factory to specified full-load rated speed.
Droop setting (internally adjusted):	Set at designated droop percentage as specified for the particular application.
Compensation needle valve:	Factory preset 1/2 turn open (nominal). Normally requires adjustment to suit the particular installation.

Make certain the speed is set to minimum (idle). Start the engine or turbine under manual control according to the engine manufacturer's recommendations, and allow it to warm up. Transfer the engine or turbine to governor control, but be prepared to resume manual control until satisfied that the governing system is fully operative.

Adjust the governor for no-load rated speed. Open the compensation needle valve (2 to 3 turns) until the engine or turbine begins to hunt or surge. Allow the engine or turbine to hunt for approximately 1/2-minute to purge trapped air from the internal passages in the governor. Gradually close the needle valve until hunting just stops. Closing the needle valve further than necessary results in a slow return to speed following a change in load. Test the governing action by manually disturbing engine or turbine speed. The engine should return promptly to original steady state speed with only a small overshoot.



WARNING

Be prepared to make an emergency shutdown when starting the engine, turbine, or other type of prime mover, to protect against runaway or overspeed with possible personal injury, loss of life, or property damage.

Storage

In cases where governors are being stored, take precaution for proper storage. Flush the governor with a corrosion preventative oil. Protect or cover all open ports and wrap the governor in a barrier material. Store it in a suitable container. Refer to manual 25075, *Commercial Preservation Packaging for Storage of Mechanical-Hydraulic Controls*.

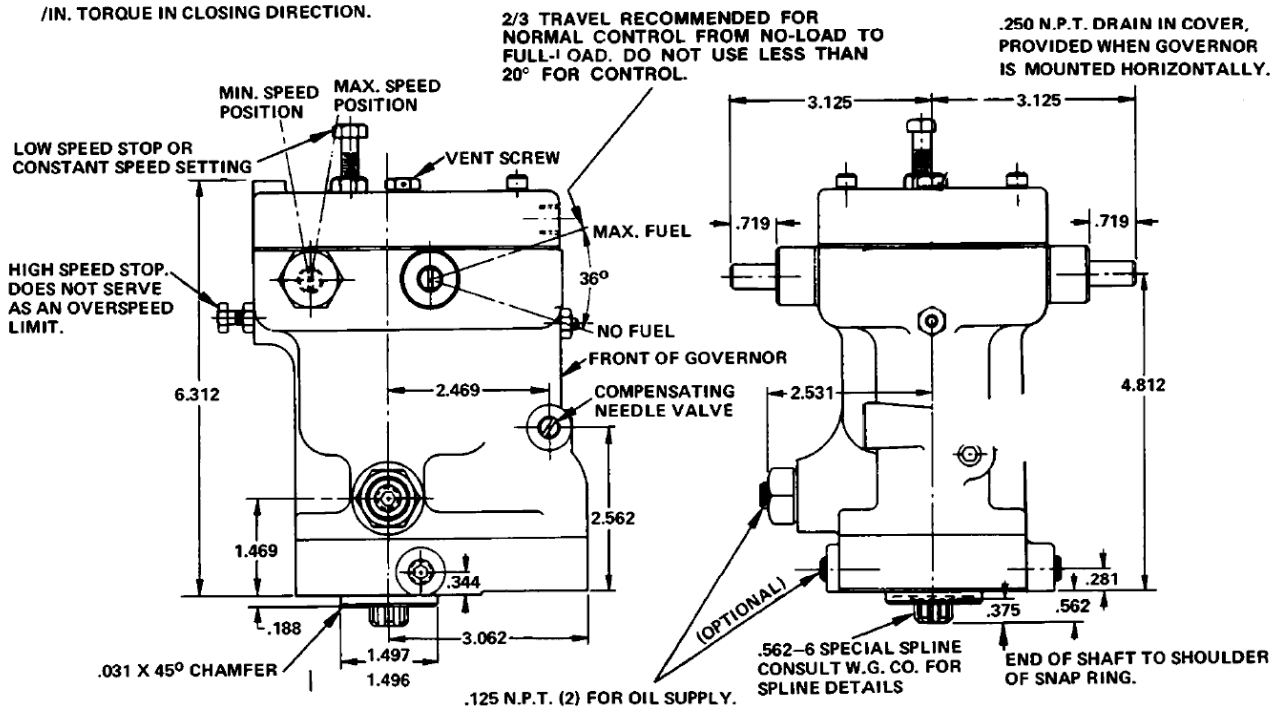
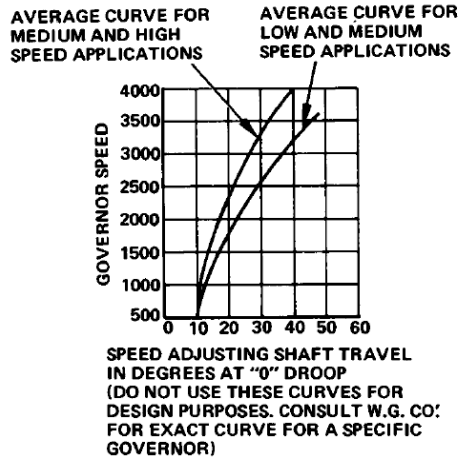
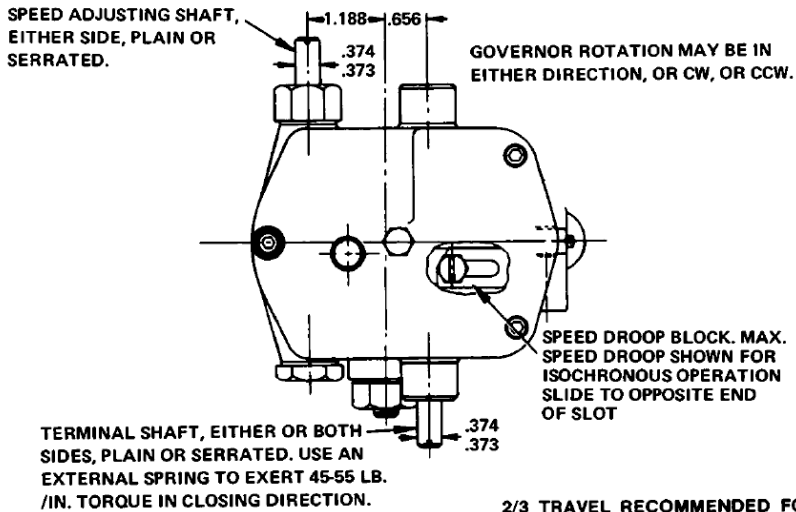

OIL SHOULD BE CLEAN LUBRICATING OIL. IF OIL FROM THE ENGINE LUBRICATING SYSTEM IS USED, IT MUST BE SUPPLIED BY A .375 INCH DIAMETER TUBING AT A MINIMUM PRESSURE OF 5 P.S.I. IF A SEPARATE SUMP IS USED, THE DISTANCE THE GOVERNOR MUST LIFT THE OIL SHOULD NOT EXCEED 12 INCHES AND A FOOT VALVE WITH A CAPACITY OF 2 GALLONS PER MINUTE MUST BE USED.

NOTE

WHEN USING OPTIONAL OIL SUPPLY, PLUG REGULAR OIL SUPPLY IN RELIEF VALVE. THE PLUGS ARE NORMALLY INTERCHANGABLE.

250 DIA. HOLE FOR OIL SUPPLY GOVERNORS FURNISHED WITH OR WITHOUT THIS HOLE AS REQUIRED.

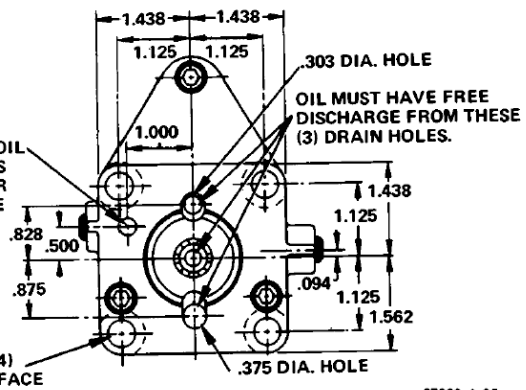

37000-A-35

Figure 1-12. Outline Drawing, Basic PSG (Do not use for construction.)

Chapter 2.

Principles of Operation

Mechanical Hydraulic System

The schematic diagram, Figure 2-1, shows the oil supply coming from the engine lubricating system. It by-passes the relief-valve into the governor oil pump where its pressure is increased to either 75, 175, or 225 psi (517, 1207, or 1551 kPa) above inlet pressure. Four check-valves, two of which are shown, permit rotation of the governor in either direction. Some models have two of the passages plugged for rotation in one direction only, depending on the particular application. Relief-valve discharge is back to supply, so unused oil is recirculated within the governor.

Pressured oil is supplied through oil passages to the pilot valve system. The pilot valve system is a three way spool valve. It applies pressured oil to the power cylinder when an under speed signal is received or releases trapped oil from the power cylinder when an overspeed signal is received.

Ballhead System

Flyweights are attached to the pilot valve's rotating bushing by pivot pins. The pilot valve bushing is driven by an external drive from the engine. A thrust bearing, located under the speeder spring, rides on the toes of the flyweights. This allows the flyweights and pilot valve bushing to rotate without extreme friction.

As the pilot valve bushing rotates, the centrifugal force increases and the flyweights pivot outward. This centrifugal force is opposed by the downward force of the speeder spring. Speeder spring compression, and therefore the speed at which the governor must run, is adjusted by the position of the speed adjusting system (e.g. lever, electric motor, or pneumatic). On speed occurs when the centrifugal force of the flyweights balances the downward force of the speeder spring, with the flyweights exactly vertical, and the pilot valve plunger control land covering the control port of the rotating bushing.

Compensation System

The compensating system consists of. a buffer piston, two buffer springs, a needle valve, and a compensating land on the pilot valve plunger. It provides temporary speed droop and must be properly attuned to the particular engine and load to provide stable operation.

Load Increase Example

The governor increases fuel to the engine with an increase in governor speed setting, or a decrease in engine speed due to an increase in load. Either the increase in the downward force of the speeder spring, or the decrease in centrifugal force of the flyweights allows the pilot valve plunger to move downward. Pressured oil is applied through the control port to the buffer system and into the power cylinder area. The power piston has two concentric areas, both of which are exposed to the pressured oil metered by the pilot valve. The lower smaller diameter is acted upon directly, and the upper annulus is connected through the bore in the power piston in which the buffer piston is carried.

Oil flow into the power cylinder forces the power piston upward against the force of the return spring (shown in Figure 2-2 only). Pressured oil displaces the buffer piston and forces oil into the upper annulus. The buffer piston, springs located in the power piston, and needle valve in the hydraulic circuits between the pilot valve plunger and power cylinder make up the buffer compensation system. This system stabilizes the governing action by minimizing over or undershoot following a change in governor speed setting, or a change in load on the prime mover. It establishes a temporary negative feedback signal (temporary droop) in the form of a pressure differential which is applied across the compensation land of the pilot valve plunger. The flow of oil into or out of the buffer system displaces the buffer piston in the direction of flow. This movement increases the loading on one spring while decreasing the other and creates a slight difference in the pressures on either side of the piston with the higher pressure on the side opposite the spring being compressed. These pressures are transmitted to opposite sides of the plunger compensation land and produce a net force, upward or downward, which assists in re-centering the plunger whenever a fuel correction is made.

Load Decrease Example

The governor decreases fuel to the engine with a decrease in governor speed setting or an increase in engine speed due to a decrease in load on the engine.

Due to the decrease in speed setting or decrease in load, the centrifugal force of the flyweights overcomes the speeder spring force and lifts the pilot valve plunger. Upward movement of the pilot valve plunger opens the control port to drain and the power piston is forced in the reduced fuel direction by the return spring. At the same time, flow of oil output of the annular space between the two diameters of the power piston un-centers the buffer piston in the downward direction. The pressure difference on each side of the buffer piston, acts on the compensating land, and re-centers the pilot valve plunger. Oil leaks by the needle valve, and dissipates this pressure difference. As the engine returns to steady state speed, the centrifugal force of the flyweights is again balanced with the downward force of the speeder spring.

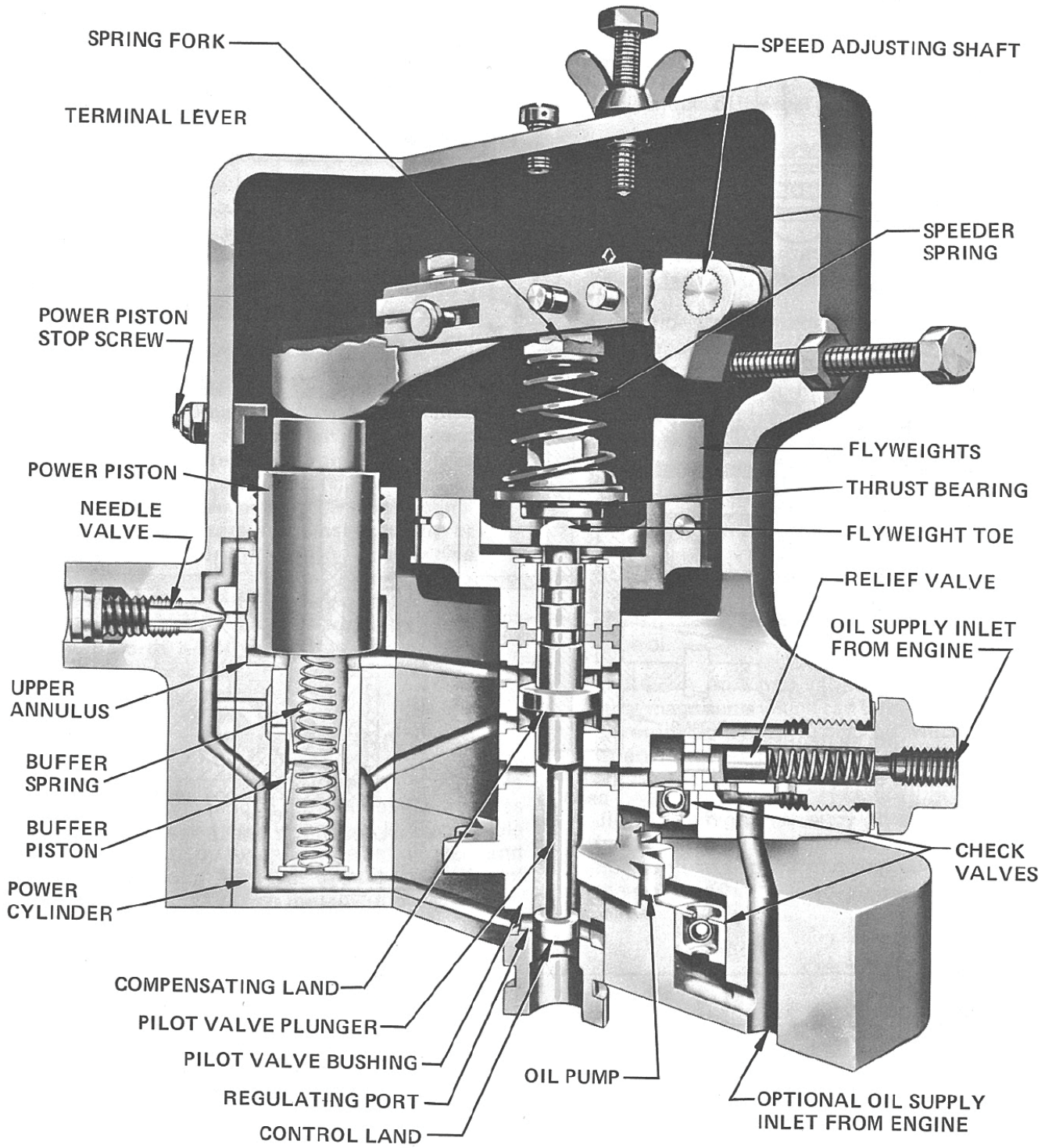

Figure 2-1. Cutaway Schematic, Basic PSG

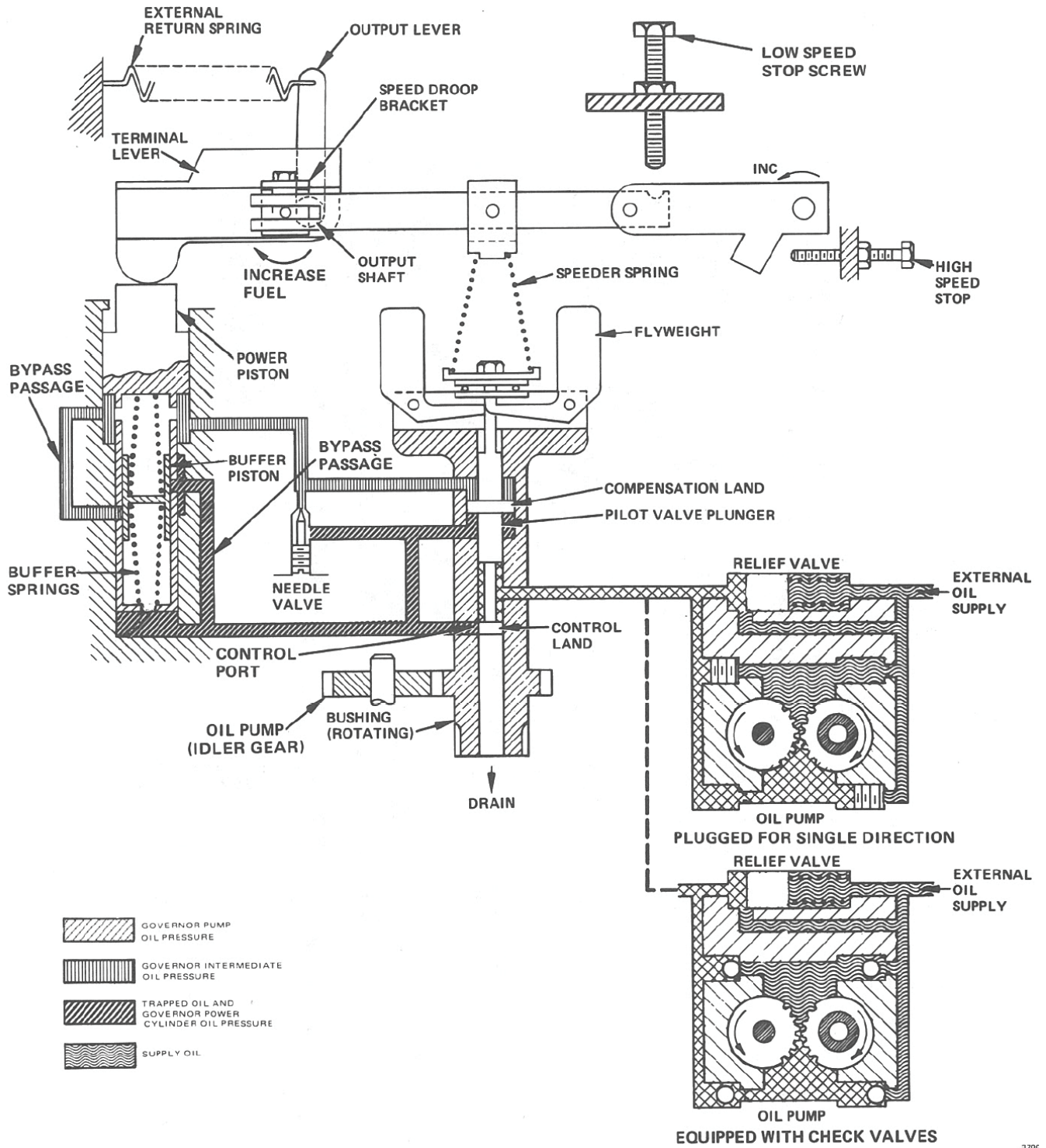

Figure 2-2. Schematic Diagram, PSG with External Return Spring

Chapter 3. Maintenance

Introduction

This chapter covers various steps for maintenance of the PSG governor. The portion on troubleshooting provides valuable information if trouble occurs. Following this are adjustments for curing minor troubles. If minor adjustments do not help, removal of the governor from the engine for either a complete overhaul or return to our plant for repair and testing may be required. Adequate instructions are provided for disassembly, reassembly and testing of your governor. However, the test specifications for the particular governor must be requested from our plant.

WARNING

The engine, turbine, or other type of prime mover should be equipped with an overspeed shutdown device to protect against runaway or damage to the prime mover with possible personal injury, loss of life, or property damage.

The overspeed shutdown device must be totally independent of the prime mover control system. An overtemperature or overpressure shutdown device may also be needed for safety, as appropriate.

Troubleshooting

Use Troubleshooting Table 3-1 to determine probable causes and recommended corrections for troubles which may be encountered in the field. Every possible trouble that might occur cannot be anticipated, and in some instances may be due to faulty operation of equipment associated with the governor.

Consider the following effects when troubleshooting apparent malfunctions of the governor.

- Effects of the oil supply system.
- Effects of the fuel or steam control mechanism.
- Effects of excessive backlash or binding in linkages.
- Effects of improper operation of the engine or turbine.
- Effects of excessive load.

Governor troubles such as erratic operation and poor repeatability are almost always caused by dirty oil. Remove the governor and give it a thorough cleaning to correct this type of trouble. The use of non-petroleum base solvents is not recommended as it may damage oil seals or gaskets. Since dirty oil causes many governor troubles, use clean, new or filtered oil.

Terms used in the table are defined as follows:

HUNT—A rhythmic variation of speed which can be eliminated by blocking governor operation manually but which will recur when returned to governor control.

SURGE—A rhythmic variation of speed, always of large magnitude, which can be eliminated by blocking governor action manually and which will not recur when returned to governor control unless speed adjustment is changed or the load changes.

JIGGLE—A high frequency vibration of the governor fuel rod end (or terminal shaft) and fuel linkage. Do not confuse this with normal controlling action of the governor.

Table 3-1. Troubleshooting

Trouble	Probably Cause	Correction
Engine, turbine or other type of prime mover hunts or surges.	Compensation needle valve opened too far.	Adjust needle valve as described in Chapter 1.
	Dirty or foaming oil. Loading or power piston sticking.	Remove and drain governor and flush with fuel oil or kerosene. Check oil supply system for air entrainment or proper type of oil. Clean or replace filter. Change oil. Disassemble governor, if necessary, and clean.
	Improper relationship between governor output shaft travel and engine or turbine power output.	Governor shaft travel to power output should be approximately linear. Readjust or rework linkage to obtain a linear relationship between engine horsepower and output shaft position.
	Excessive backlash or binding in linkage.	Repair linkage.
	Excessive backlash or binding in fuel or steam control.	Repair fuel or steam control.
	Insufficient utilization of governor output shaft travel.	Readjust or rework linkage to use more governor output shaft travel.
	Negative droop set into governor.	Set correct percentage of positive droop.
	Governor case flooded with oil. Case drain line or drain through pilot valve bushing plugged or restricted.	Clean drain passages and rework the drive to the governor to provide unrestricted drain. No back pressure is tolerated. Also, the drain passages in the case cavity must be free of back pressure.
	Buffer spring(s) fatigued or broken. Springs too light.	Replace spring(s). Install heavier springs (consult Woodward).
	Governor parts worn (excessive internal leakage) or not correctly adjusted.	<p>Repair governor by replacing worn parts.</p> <p>Check flyweight pins and bearings for wear.</p> <p>Check flyweight toes for wear and/or flat spots.</p> <p>Check flyweight head thrust bearing, also centering bearing.</p> <p>Pilot valve plunger may be sticking—clean and polish if necessary.</p> <p>NOTICE Do not break or damage corners of control land.</p> <p>Check centering of pilot valve plunger and correct if necessary.</p> <p>Clean and polish all moving parts to ensure smooth and free operation.</p>
Power piston sticking in cylinder.	Repair if possible by cleaning and polishing.	

Trouble	Probably Cause	Correction
<p>Jiggle at governor output shaft.</p>	<p>Rough engine or turbine drive.</p>	<p>Check drive gear alignment.</p> <p>Inspect gear teeth for roughness.</p> <p>Check gear train for eccentricity or excessive backlash.</p> <p>Check gear mounting on shafts for looseness.</p> <p>Tighten camshaft drive chain, if used.</p> <p>Check vibration dampener, if used.</p> <p>Check for cyclic load variation.</p>
	<p>Failure of spring-driven flyweight head, if used.</p>	<p>Remove flyweight head assembly and check operation or torsion spring. Disassemble and clean parts. Replace torsion springs if fatigued or broken. Check for accumulated dirt.</p>
	<p>Governor not mounted squarely on drive pad.</p>	<p>Loosen governor on pad and realign. Tighten attaching bolts or nuts evenly to proper torque value.</p>
<p>Fuel or steam control does not open sufficiently or quickly during starting.</p>	<p>Low governor oil pressure.</p>	<p>Check governor oil supply system for restriction or foaming oil. Eliminate restriction. Clean or replace filter. Check for proper oil viscosity. Change oil.</p> <p>Check governor oil pressure relief valve for sticking plunger, fatigued or broken spring. Free plunger. Replace worn or damaged parts.</p> <p>Inspect pump check valves for operation. Clean or replace leaking check valves.</p> <p>Check governor pump gears and gear pockets for excessive wear. Replace worn parts.</p>

Trouble	Probably Cause	Correction
Prime mover is slow to return to speed following a change in load or is slow in responding to a change in speed setting.	Compensation needle valve closed too far.	Adjust needle valve as described in Chapter 1.
	Prime mover is overloaded.	Reduce load.
	Compensation buffer piston sticking.	Remove governor and clean it thoroughly. Reinstall governor and clean or replace filter in oil supply system.
	Governor case flooded with oil. Case drain line or drain through pilot valve bushing plugged or restricted.	Clean drain line or drain passages in pilot valve bushing. Rework the drive to the governor to provide unrestricted drain.
	Low governor oil pressure.	<p>Check governor oil supply system for restriction or foaming oil. Eliminate restriction. Clean or replace filter. Check for proper oil viscosity. Change oil.</p> <p>Check governor oil pressure relief valve for sticking plunger, fatigued or broken spring. Free plunger. Replace worn or damaged parts.</p> <p>Inspect pump check valves for operation. Clean or replace leaking check valves.</p> <p>Check governor pump gears and gear pockets for excessive wear. Replace worn parts.</p>
	Incorrect buffer springs in governor.	Install correct buffer springs (consult Woodward).
	Fuel supply restricted, or engine may be overloaded.	Clean fuel filters and fuel supply lines. Reduce the load.
Governor output shaft goes to and remains at full travel regardless of speed setting or load.	Pneumatic speed setting-pressure trapped in air chamber due to clogged orifice in air inlet, or speed setting too high.	Clean orifice.

Trouble	Probably Cause	Correction
No output from governor.	Power piston sticking because of dirty oil.	Remove and drain governor and flush with fuel oil or kerosene. Clean or replace filter in oil supply system. Change oil. Disassemble governor, if necessary, and clean.
	No governor oil pressure.	<p>Check oil supply system.</p> <p>Check governor oil supply system for restriction or foaming oil. Eliminate restriction. Clean or replace filter. Check for proper oil viscosity. Change oil.</p> <p>Check governor oil pressure relief valve for sticking plunger, fatigued or broken spring. Free plunger. Replace worn or damaged parts.</p> <p>Inspect pump check valves for operation. Clean or replace leaking check valves.</p> <p>Check governor pump gears and gear pockets for excessive wear. Replace worn parts.</p> <p>Engine or turbine cranking speed too low.</p>
	Failure of drive to governor.	Repair the drive to the governor.
	Damage to internal governor parts.	Disassemble governor, replace damaged parts.
	Linkage binding or maladjusted.	Repair or readjust linkage.
No response to changes in control air pressure setting. (Pneumatic Speed Setting)	Dirty oil. Loading or power piston or linkage sticking.	Remove and drain governor and flush with fuel oil or kerosene. Clean or replace filter in oil supply system. Change oil. Disassemble governor, if necessary, and clean.
	Diaphragm ruptured.	Replace diaphragm.
	Control air pressure relief valve sticking in open position. Spring fatigued or broken.	Clean relief valve. Repair or replace relief valve.
Excessive overspeed with inadvertent control air over-pressure. (Pneumatic Speed Setting)	Control air pressure relief valve set too high.	Readjust or replace relief valve.
	Orifice in control air pressure inlet too large or missing.	Replace orifice.
Minimum and/or maximum control air pressures do not result in the desired idle or rated speeds. (Pneumatic Speed Setting)	Governor speed settings not properly adjusted.	Adjust governor speed settings as described in Test Section.

Trouble	Probably Cause	Correction
Engine, turbine or other type of prime mover will not carry full rated load.	Fuel or steam control does not fully open.	Check and adjust linkage. Check for binding in fuel or steam control.
	Low governor oil pressure.	<p>Check governor oil supply system for restriction or foaming oil. Eliminate restriction. Clean or replace filter. Check for proper oil viscosity. Change oil.</p> <p>Check governor oil pressure relief valve for sticking plunger, fatigued or broken spring. Free plunger. Replace worn or damaged parts.</p> <p>Inspect pump check valves for operation. Clean or replace leaking check valves.</p> <p>Check governor pump gears and gear pockets for excessive wear. Replace worn parts.</p> <p>Engine or turbine cranking speed too low.</p>
	Fuel racks do not open far enough.	<p>Check fuel pump stops and adjust as necessary. Also, check governor to fuel rack relationship.</p> <p>Check linkage between governor and fuel pumps and adjust if necessary.</p> <p>Oil in governor may be too light, change to next heavier grade (see manual 25071).</p>
	Gas pressure too low.	Adjust pressure regulator in gas supply line.
	Slipping clutch (if used) between engine and driven load.	See Clutch Instruction Manual.
	Voltage regulator (if used) not functioning properly.	Readjust or repair voltage regulator.
Improper load division between paralleled units. One unit on zero droop—all others on droop.	Incorrect speed droop setting on one or more of the droop units.	Increase droop on affected units until load remains steady on each droop unit. System load variation is absorbed by the lead unit with zero droop. Droop units assist in correcting speed deviations on large load changes, but return to their original loads after the load change is absorbed by the lead unit.
	Different speed settings among the droop units.	Readjust speed setting on improperly set unit.
Improper load division between paralleled units. All units on droop.	Incorrect speed droop setting on one or more units.	Adjust droop on each unit until desired division of load is obtained. Increasing droop results in the unit taking a smaller share of load changes; decreasing droop, a larger share.
	Different speed settings between units.	Readjust so that all speed settings are the same.

Speed Droop Adjustment

Figure 3-1 shows the governor with the top cover removed to expose the speed droop mechanism and adjustments. The speed droop bracket is clamped to the terminal lever by the slotted hexagonal head screw.

The speed droop bracket, when loosened, is adjustable radially to the terminal shaft. When the bracket is moved, a pin on the bracket is moved radially from the terminal shaft's centerline to a radius of 1/2 inch (12.7 mm). This pin controls the position of the speed droop lever. When the pin is set at the centerline of the terminal shaft, the governor is set at zero droop. As the pin is moved away from the shaft's centerline, terminal shaft rotation moves the pin and, therefore, the end of the speed droop lever which pivots on the speed droop pin. The resultant speed setting is a function of terminal shaft position with speed setting decreasing as fuel flow increases.

Since there is no calibration for the droop adjustment, the zero droop position may be set only by trial and error on the engine, or by use of a dial indicator on the speed droop lever during manual rotation of the terminal shaft. If speed droop is required, it must be set by operation on the engine, readjusting the slide to obtain the desired speed droop between full load and no load.



Do not operate the governor with the cover removed.

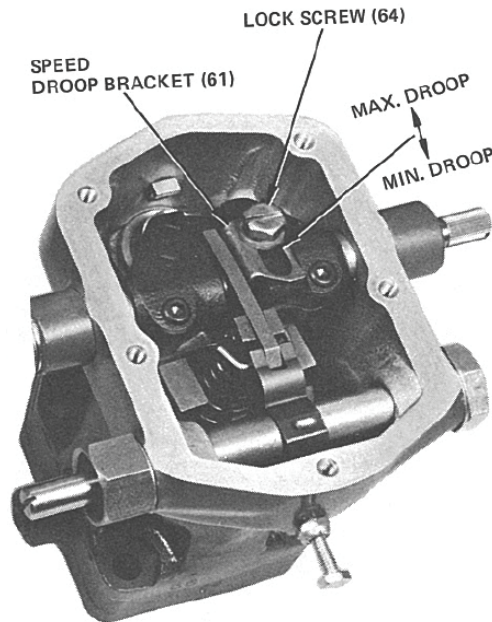

Figure 3-1. Droop Adjustment

Removal of Governor from Engine

For major repairs, or a complete governor change, remove the governor from the engine as follows:

1. Disconnect fuel linkage from governor terminal shaft. Mark position of lever on terminal shaft before removing lever.

2. Disconnect speed adjusting linkage from governor speed control lever. Mark position of lever on speed adjusting shaft before removing lever. For electric or pneumatic speed setting options, disconnect the electrical connection or the pneumatic tubing from the governor.
3. Disconnect oil inlet connections.
4. Remove the four stud nuts holding the governor assembly to the governor drive housing and lift the governor off the studs and away from the engine. Remove the gasket between the governor and governor housing.

IMPORTANT

Use care in handling and setting down the governor. Especially avoid striking the end of the drive shaft a sharp blow as this could damage the governor's oil pump driving gear.

Tools for Disassembly and Assembly

These tools, available from Woodward, will facilitate the assembly and/or disassembly of the governor. See Table 3-2, Tool List, and Figure 3-2.

Table 3-2. Tool List

Tool Description	No.	Application
Solid Ballhead Assembly Tool	8995-075	Center Pilot Valve Plunger
Ballhead Spacer	8995-076	Center Pilot Valve Plunger
No. 1 Waldes Truarc Pliers	190497	Remove and Install Snap Ring
No. 2 Waldes Truarc Pliers	190862	Remove and Install Snap Ring
Welch Plug Assembly Tool	8995-077	Install Seal Cup
Bending Tool	8995-078	For Spring Pin for Floating Lever
Pilot Valve Plunger Wrench	370109	Center Pilot Valve Plunger
Seal Installation Tool	8995-079	Place Seal on Terminal Shaft
Seal Installation Tool	8995-080	Seat Seal in Housing
Idler Stud Installation	8995-081	Seat Idler Stud
Check Valve Assembly Tool	8995-082	Install Check Valves in Case
Check Valve Assembly Tool	8995-083	Install Check Valves in Base
Drill, 17/64" & #5 Extractor	NONE	Remove Check Valve from Base
Drill, 1/4" & #4 Extractor	NONE	Remove Check Valve from Case
Hard Arkansas Stone		Polish Nicks and Burrs
Seating Tool (Figure 3-14)	8995-084	Seat Retaining Ring
Droop Alignment Tool (Figure 3-28)	8995-085	Set Zero Droop

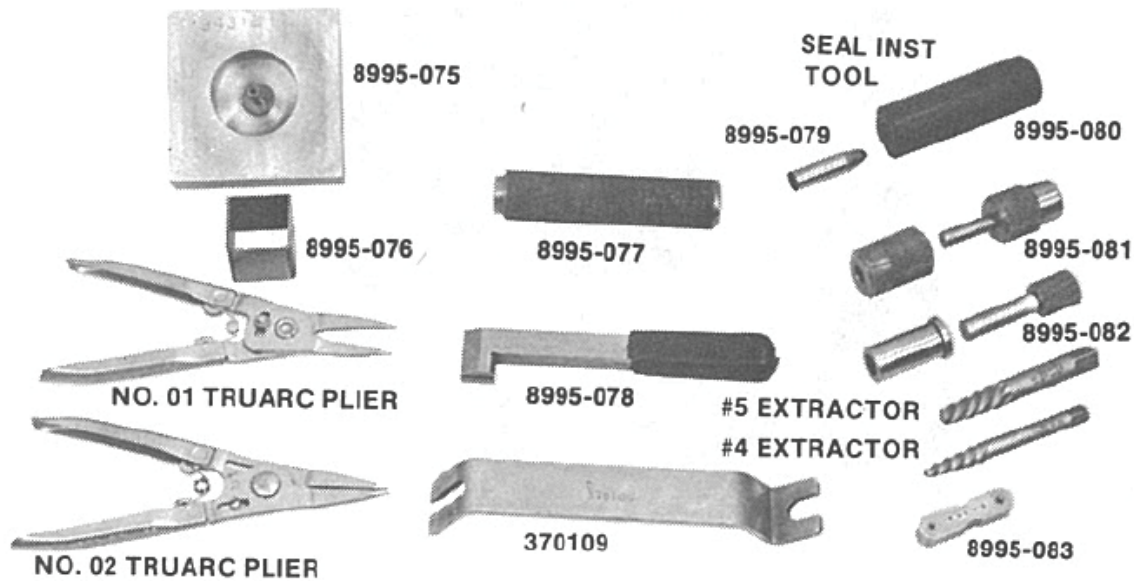

Figure 3-2. Assembly Tools

Disassembly of Governor

Refer to the exploded view, Figure 4-1, and the following steps for governor disassembly and assembly. Some PSGs have slightly different arrangements, however, these instructions apply to most PSGs. The exploded view is very helpful when assembling or disassembling a governor. Before removing speed adjusting screws, needle valve, and droop bracket, record their position for future use in reassembly.

IMPORTANT

Do not disassemble the governor any more than necessary for the particular repairs required.

1. Clamp governor lightly in vice, using soft jaws below case to base joint.
2. Remove screws (68) and take off top cover (67).
3. Mark position of speed droop bracket (61), if removed from terminal lever (56), to permit reassembly with bracket in approximately the same position.
4. Remove pin (54) that holds the fork of speeder spring assembly (42) to the floating lever (55). Remove lever (55).
5. Remove two socket head screws (60) in terminal lever (56) and pull out terminal shaft (58). Remove two oil seal rings (47) from terminal shaft sleeve (46).
6. Use a 5/16" diameter brass rod and insert it through terminal sleeve (46) and lever (56). Drive out the opposite stub shaft (57) and Welch plug (65) from the sleeve (45) and lift out terminal lever (56). See Figure 3-3.
7. Unscrew the speed adjusting spacer sleeve (49) and the spacer cap (50) on opposite side of governor case, and remove them from case along with the copper washers (48).

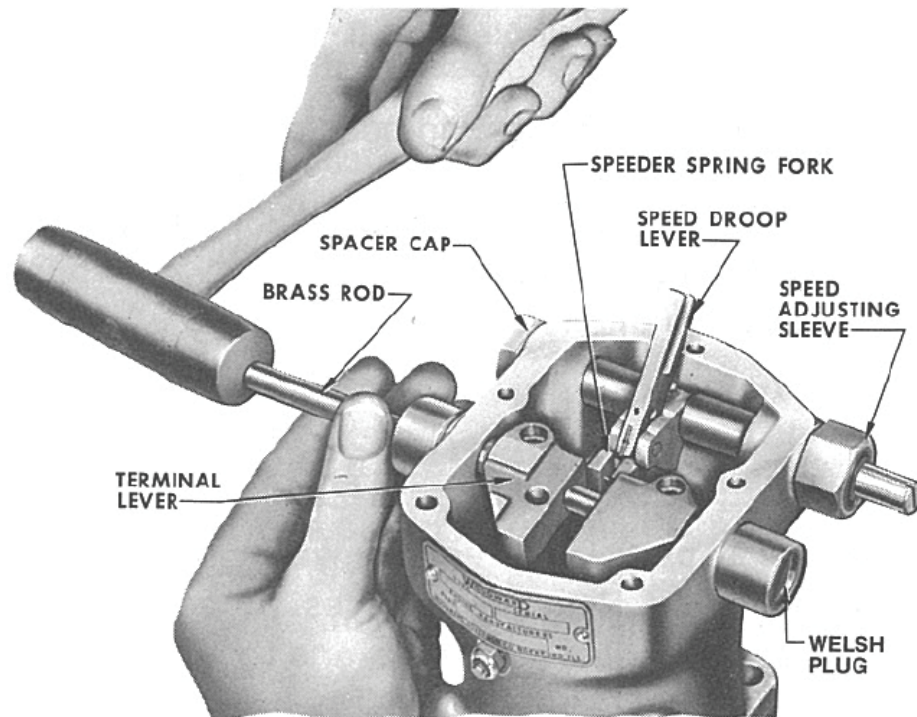

Figure 3-3. Terminal Shaft Removal

8. Remove the speed adjusting shaft (52) along with the speed adjusting lever (51), only if necessary. To facilitate correct assembly, the speed adjusting shaft end is slotted in line with the cotter pin hole.
9. Remove power piston stop screw (items 3, 4, and 5).
10. Lift out power piston (16), buffer piston (14), buffer springs (13 and 15), spring seat (12), and snap ring (11) as an assembly.
11. To disassemble the buffer parts, remove the snap ring (using snap ring pliers). The buffer spring seat, lower spring, buffer piston, and upper spring can now be removed from the power piston bore.
12. Use pilot valve wrench (Woodward part no. 370109) and wedge it between the coils of speeder spring assembly (42) and spring seat (40). Hold the spring fork and bend spring towards open end of bottom coil. At the same time, turn spring to disengage coil from seat lip. See Figure 3-4.
13. Hold spring seat (40) with the short end of tool 370109 and use a 5/16" socket wrench to remove the pilot valve plunger lock nut (41). See Figure 3-5.
14. Place a small screwdriver in the slot in the top of pilot valve plunger (31) and screw the pilot valve plunger down and out of spring seat (40).
15. Lift out spring seat (40) and thrust bearing assembly (39). The thrust bearing consists of an upper and lower race and a bearing assembly.
16. Remove snap ring (37) with snap ring pliers and lift out ballhead parts (34, 35, 36, 37, and 38). See Figure 3-6.

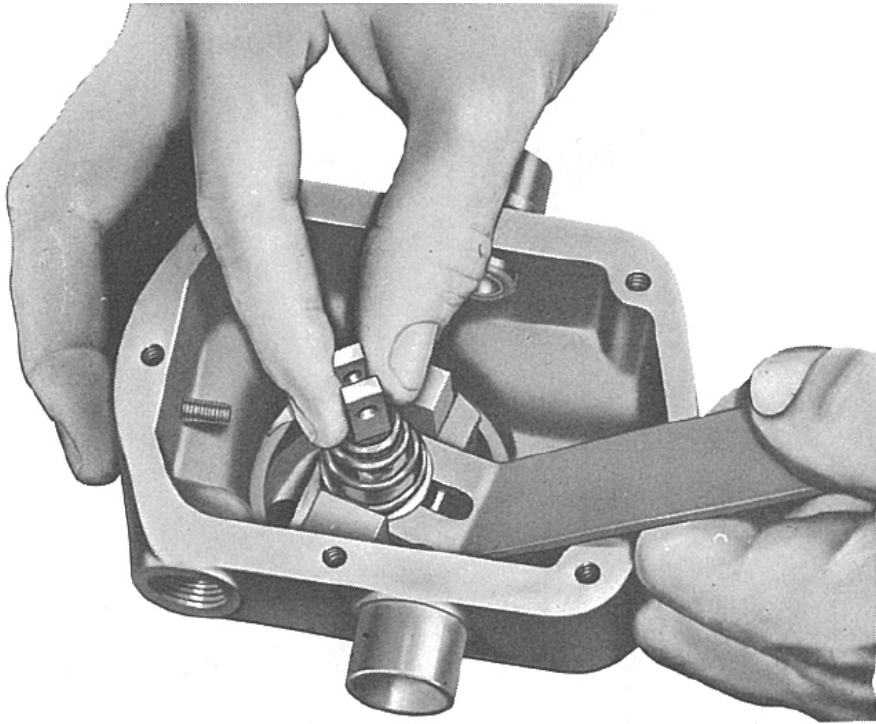

Figure 3-4. Speeder Spring Removal

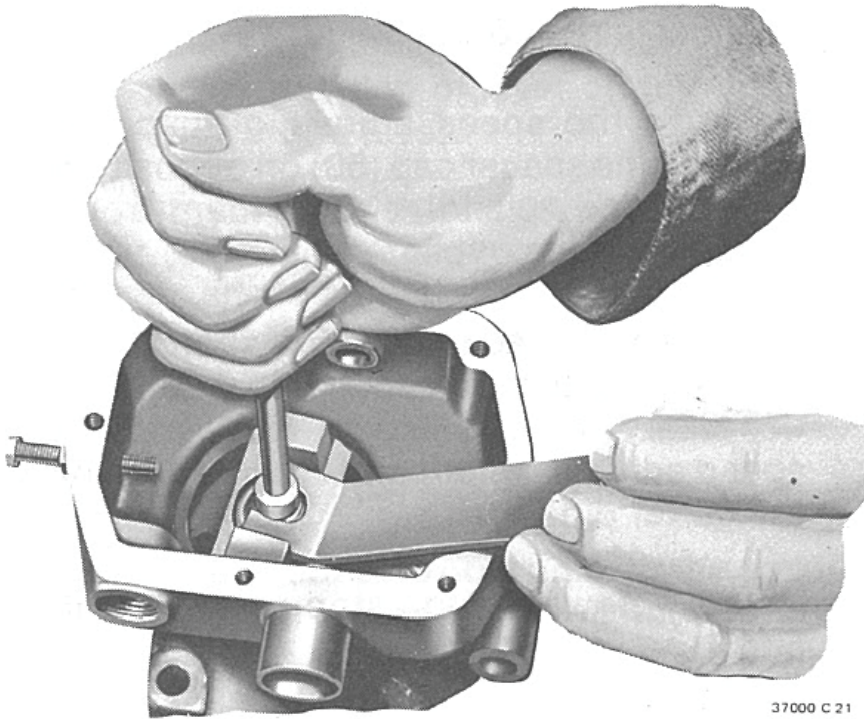

Figure 3-5. Pilot Valve Disassembly

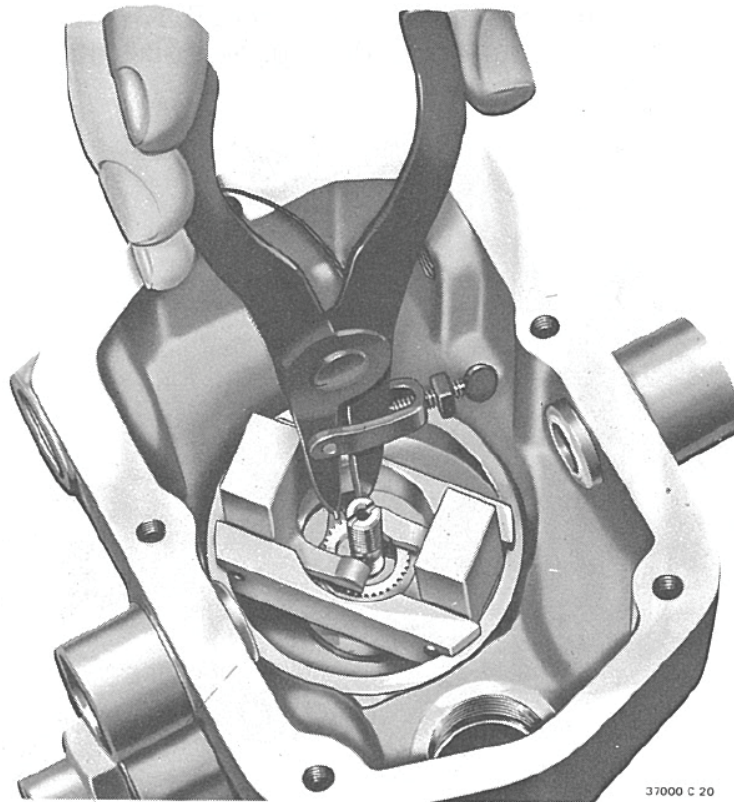

Figure 3-6. Removal of Ballhead

17. Remove screws (76) from the base and carefully tap and pry the base, until the dowel pins holding the base to the case are free, and separate the base and case.

IMPORTANT

Be careful when separating the base from case as loose parts can be dropped and damaged.

18. Remove pilot valve bushing (30) and idler gear (28) from the case.

NOTICE

Do not damage gear teeth.

19. Remove internal snap ring (33) from the upper end of the pilot valve bushing.
20. Separate compensating bushing (32) and pilot plunger (31) from pilot valve bushing (30).

NOTICE

Do not damage any edges on the pilot valve plunger.

21. Use a proper size wrench and remove the relief valve assembly, items 17 through 21. Do not disassemble the relief valve if it is inoperative. Replace the complete unit.

22. Remove compensating needle valve (6).
23. Remove plugs (26) from base (23). Replace the plugs in the same locations as they determine direction of oil flow.

Parts Cleaning

Immerse all parts in solvent and wash ultrasonically or by agitation. Remove all traces of contaminants from corners, holes apparatus, and threads.

Dry all parts with clean wipers or blow dry with a jet of clean, dry air.

Parts Check

Make a visual check of all parts for the following:

1. Check all parts for wear, corrosion, cracks, nicks, and burrs.
2. Check threads for stripping or cross-threading.
3. Check for mis-matching of serrations or other tooth damage.
4. Check idle gear and stud for wear in mating parts.
5. Check power cylinder bushing for wear. If worn excessively, obtain a replacement case. The power piston must move freely in its cylinder.
6. Check toes of flyweights for flat spots. Replace flyweights in sets if the ones removed have large flat spots.
7. Check all pivot pin holes and pivot pins for wear.
8. Check that the pilot valve plunger has square edges on the control lands.
9. Check all bushings and bearings for wear.
10. Check pump gear teeth and idler stud for wear.
11. Check that the pilot valve plunger moves freely in the pilot valve bushing.
12. Check the lower race of the thrust bearing for wear pockets caused by the flyweights.
13. The buffer piston must slide freely in the buffer cylinder. Also, check that the grooves around the buffer piston are clean. Grit and dirt in the system may freeze the buffer piston.
14. With the governor at room temperature, inspect the power piston and ballhead bushings. A practical check for disallowable bushing shift is to draw a sharp lead pencil across the joint between the bushing and the case bottom. If a step is felt, the case should be discarded. In no instance can a case be used if bushing shift is greater than 0.0005 inch (0.013 mm). The case may be reused if the shift is less than 0.0005 (0.013 mm) but do not attempt to press the bushing back into position.

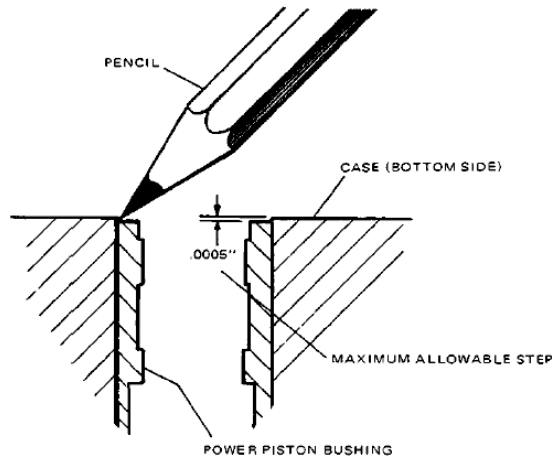

Figure 3-6A. Bushing Shift Check

Parts Repair

The following may be sufficient to repair a damaged part, if not replace the part.

1. Chase any damaged threads.
2. Polish corroded areas with a hard Arkansas stone.
3. Remove flat spots from the flyweight toes with the hard Arkansas stone. If at all possible replace the flyweights with new ones.
4. Replace all O-rings and seals.

Assembly

Perform assembly in a dust-free environment. Before assembly, refer to Figure 4-1 for familiarity of the PSG. Lightly oil all parts during assembly.

During a major overhaul replace all the following parts:

1. O-rings, copper washers, and Welch plugs.
2. Oil seals on terminal shaft and speed adjusting shaft.
3. Spring wire pin (54, Figure 4-1).
5. Rotational plugs, if damaged or brittle (26, Figure 4-1), or ball check valves (if applicable).
6. Idler gear (28) and stud (29) if wear is apparent, or if there is too much play in gear to stud mating.

A major overhaul is necessary if the governor oil is quite dirty, or if the governor has been in service for a considerable length of time.

For minor repairs and a good cleaning, it is not normally necessary to replace all of the above parts. The main things to replace are the O-rings and oil seals. Lubricate all O-rings with a petrolatum when replacing them.

1. Replace all plugs removed from the governor case and base. Use Loctite Sealant No. 242 to seal the plugs. Put sealant on plug threads and not in hole.

IMPORTANT

If tools 8995-075 and 8995-076 (Figure 3-22) are not available, leave out 1/8" pipe plug (77), in line with pilot valve bushing (30), on governor base until after the pilot valve plunger is assembled and adjusted.

2. Seat new check valves in both base and case as shown in Figure 3-7. Use tool 8995-083 for seating valves in base.

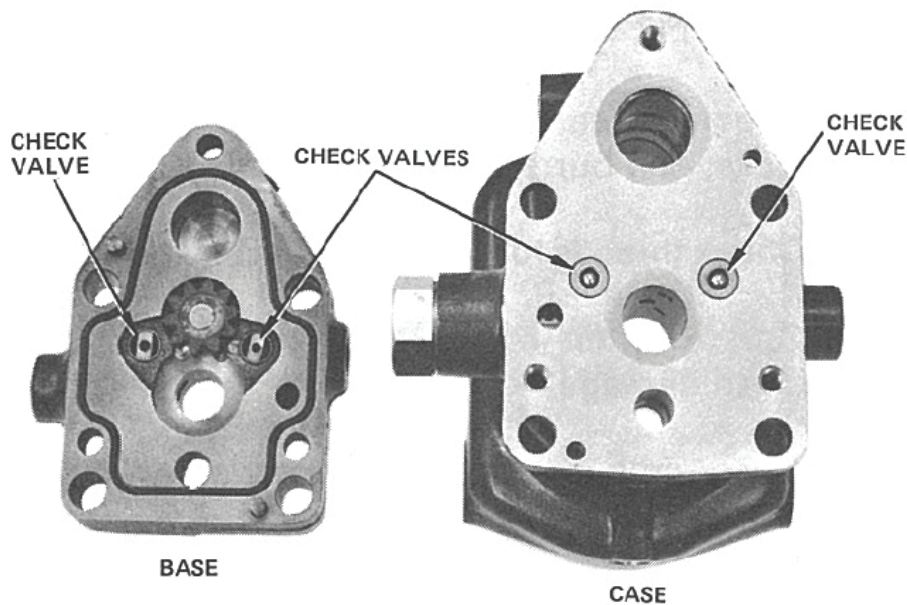

Figure 3-7. Check Valve Assembly

3. Use 8995-082 for seating valves in case. Both tools seat the valves to the correct depth.
4. Place idler stud (29), if previously removed, in I position.
5. Seat idler stud gear (28) in base with tool 8995-081 as shown in Figure 3-8.
6. If check valves are not used, the governor is plugged for one direction rotation. Rotational direction is determined by viewing the drive pad on the prime mover and observing the direction of rotation of the drive coupling. Figures 3-9 and 3-10 show plugs with O-rings installed for CCW and CW rotation respectively.
7. Assemble pilot valve plunger parts as shown in Figure 3-11 and 3-12.
8. Use Waldes Truarc pliers to fit retaining ring (37) into top of pilot valve plunger. Finish seating retaining ring into inside groove with tool 8995-084. See Figure 3-13.

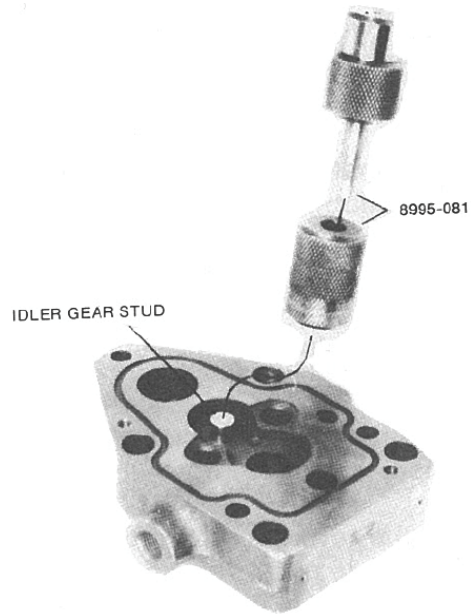

Figure 3-8. Install Idler Gear Stud and Gear

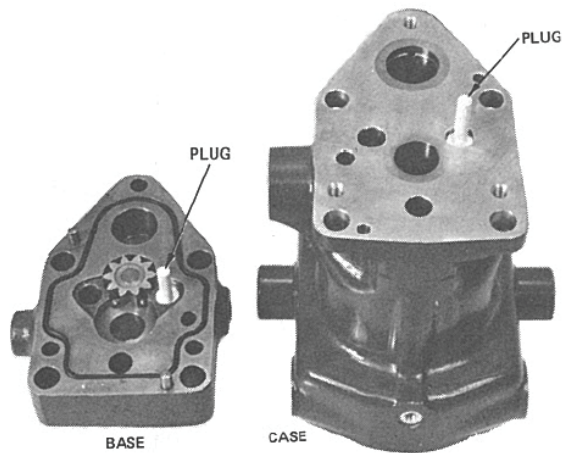

Figure 3-9. Plugs Inserted for CCW Rotation

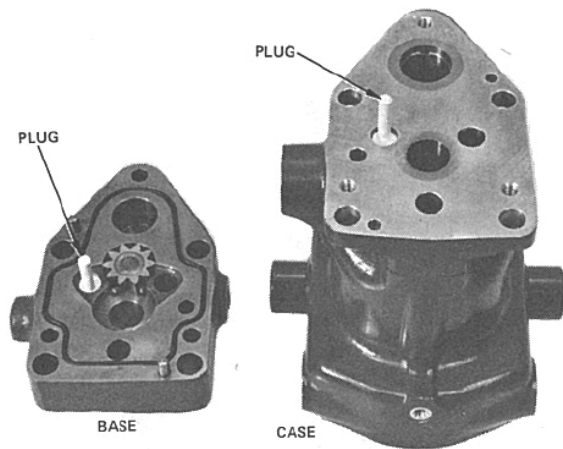

Figure 3-10. Plugs Inserted for CW Rotation

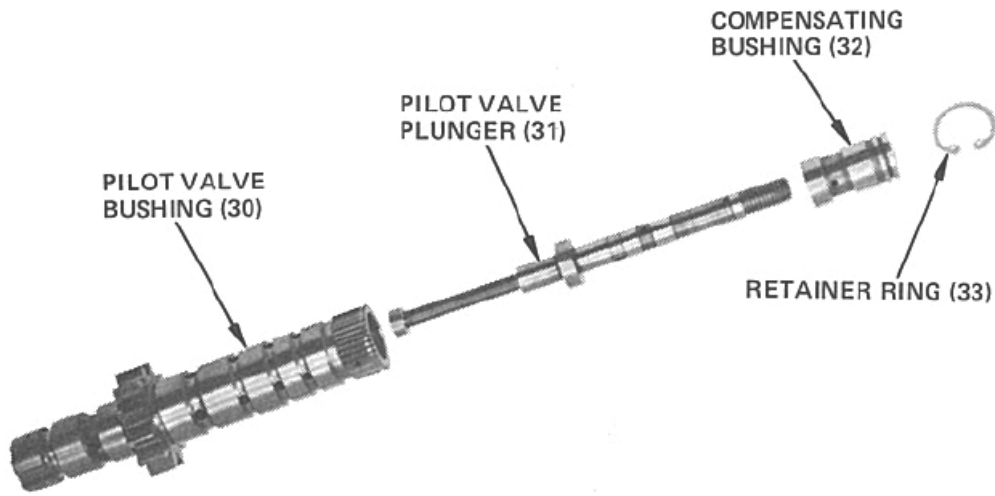

Figure 3-11. Pilot Valve Bushing Assembly

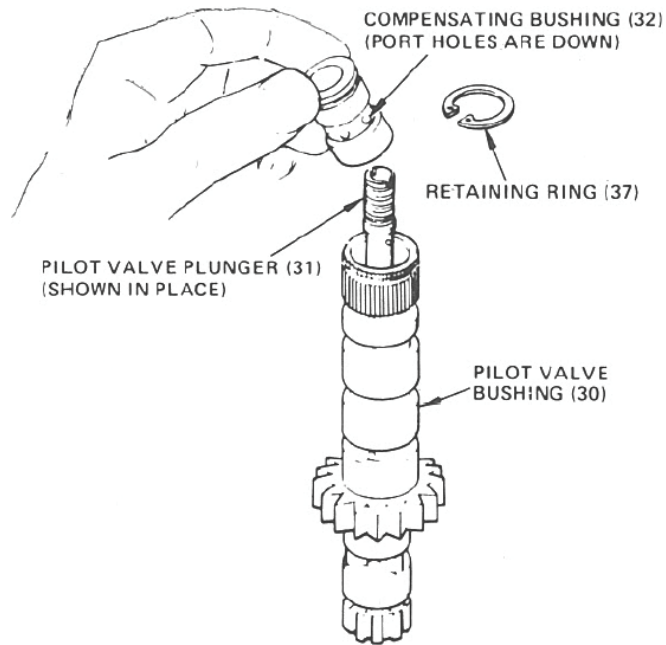

Figure 3-12. Compensating Bushing Assembly

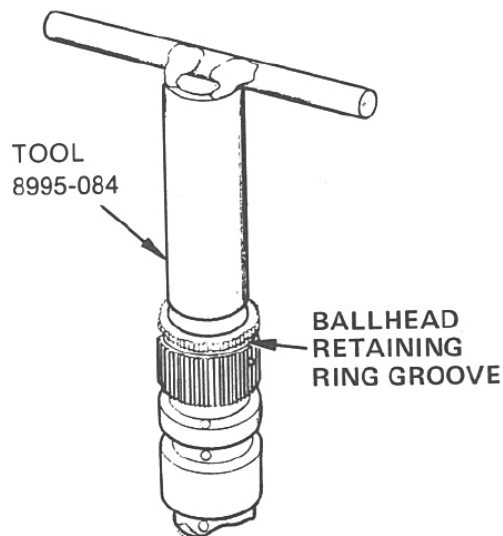

Figure 3-13. Seating Retaining Ring

9. Assemble base (23) to case (1) with parts as shown in Figure 3-14. Insert bushing (30) in case and idler gear (28) in base. Place oil seal ring (74), flat wide side down, in groove provided in base. Secure base to case with three screws (76) and washers (75). Check that the pilot valve bushing rotates freely. It may be necessary to loosen the base, free the gears and then retighten the base.

IMPORTANT

If alignment pins are damaged they must be replaced.

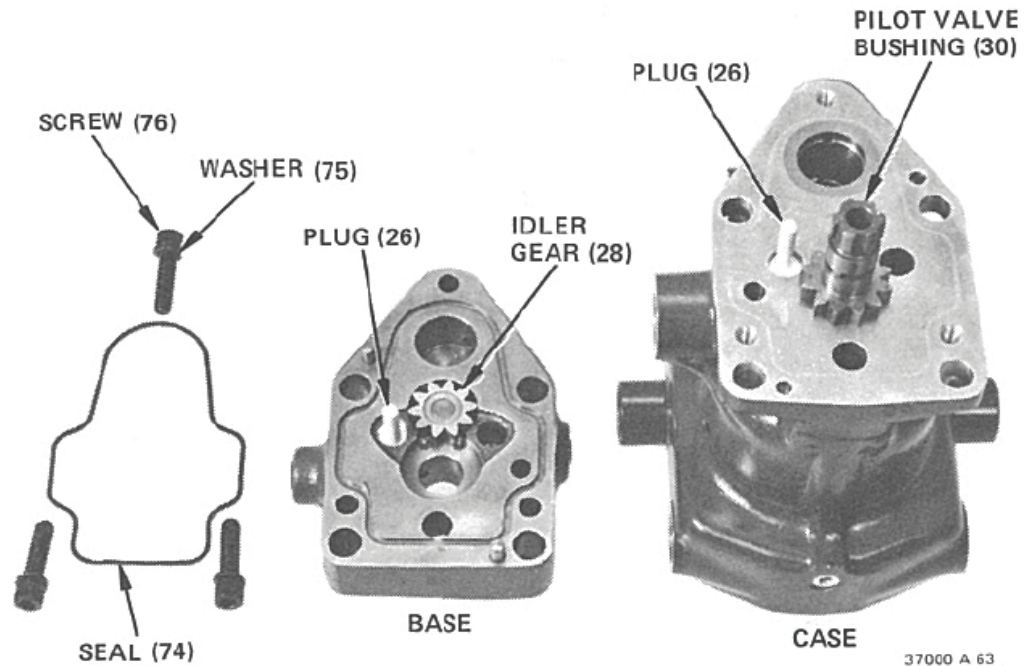

Figure 3-14. Base to Case Assembly

10. Assemble buffer system parts (11 through 15) into power piston (16) if previously disassembled for purposes of cleaning. See Figure 3-15 and note position of holes in buffer piston. They must be in this position for proper operation.

WARNING

Injury may result if compressed springs are suddenly released. Use the proper equipment to remove springs and spring covers.

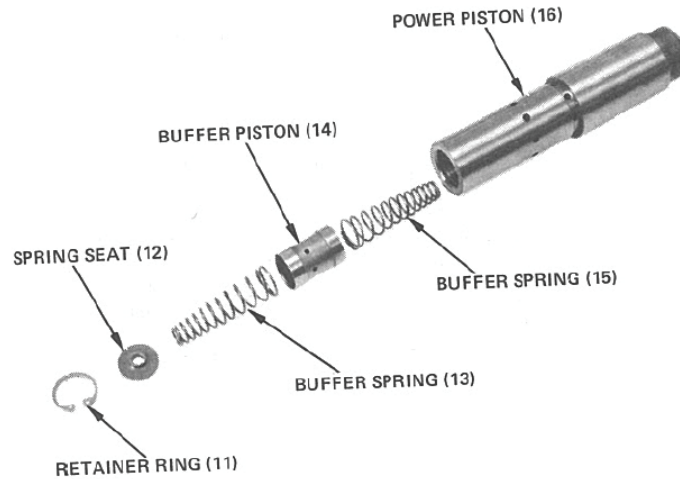

Figure 3-15. Buffer System Assembly

11. Place piston into case as shown in Figure 3-16 and 3-17.

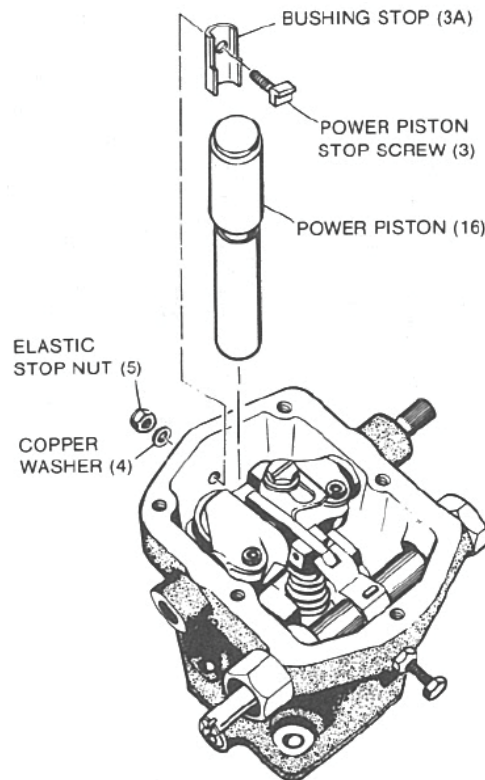

Figure 3-16. Power Piston Assembly

12. Install the power piston stop screw (3) and bushing stop (3A) into the case and position as shown. Secure the parts with a new copper washer (4) and elastic stop nut (5).

IMPORTANT

All PSG governors factory assembled after November 1977 include a bushing stop to prevent possible bushing movement in the event of excessive operating temperatures. Install the bushing stop in all PSG governors not previously equipped. Do not reuse the original power piston stop screw removed from the governor. Although its appearance is similar to the replacement stop screw, the two parts are not interchangeable.

13. Assemble flyweights (35) to ballhead (34) with pins (36) and secure by fitting ring (38) around ballhead assembly. If the retaining ring has a hump it must be installed with the hump positioned as shown in Figure 3-17.

Woodward replacement spirolox retaining rings have a reduced inner diameter to prevent shifting of the ring during governor operation and do not have the hump. Use care not to overstress the spirolox ring during installation.

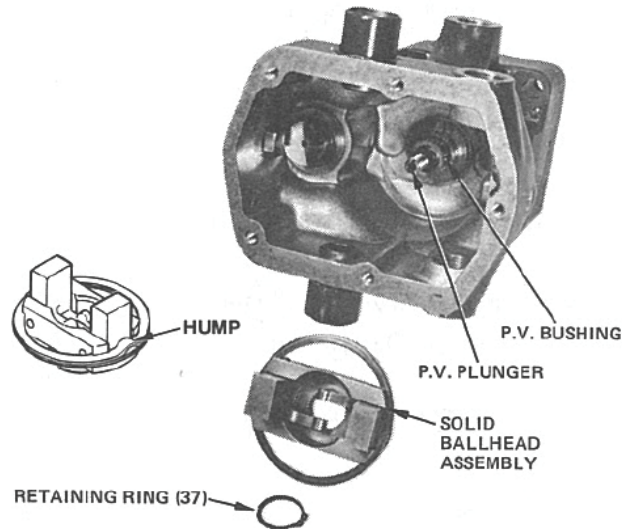

Figure 3-17. Ballhead Installation

14. Place ballhead assembly on pilot valve bushing and secure by placing retaining ring into groove on outside of pilot valve bushing. See Figures 3-13 and 3-17.
15. Assemble thrust bearing (39), spring seat (40), nut (41) and speeder spring (42). See Figure 3-18 through 3-21. Place bearing with open side down.
16. Use a screwdriver (Figure 3-19) and guide spring seat (40) and nut (41) onto pilot valve plunger. Hold the spring seat and nut, and turn plunger (31) COW threading seat (40) and nut (41) on until the nut is just below the top of the plunger, Figure 3-20.
17. Release nut (41) and continue turning plunger until spring seat (40) is bottomed.

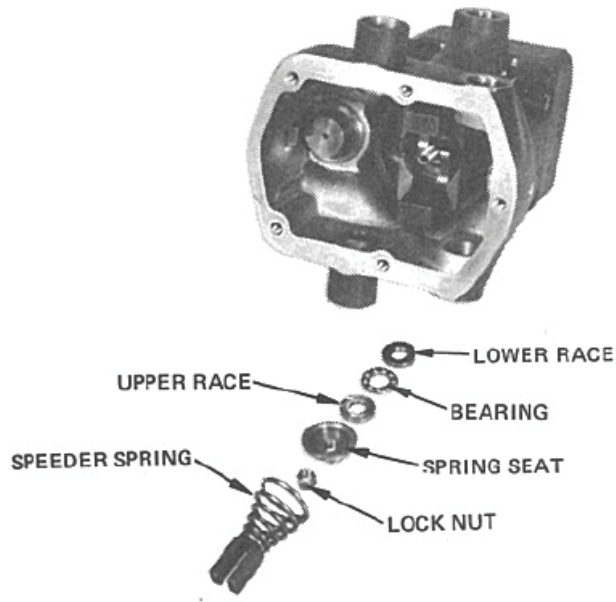

Figure 3-18. Thrust Bearing and Speeder Spring Parts

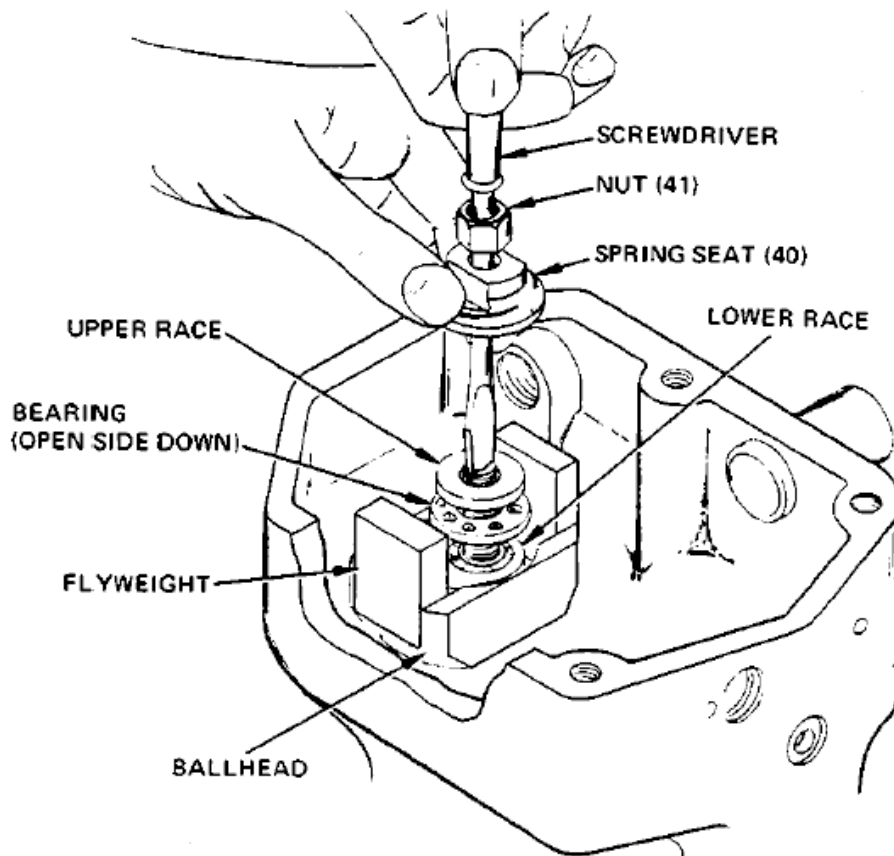

Figure 3-19. Thrust Bearing and Spring Seat Assembly

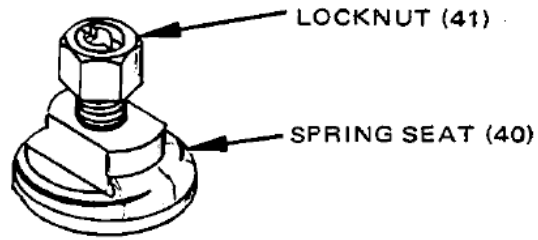

Figure 3-20. Spring Seat Adjustment

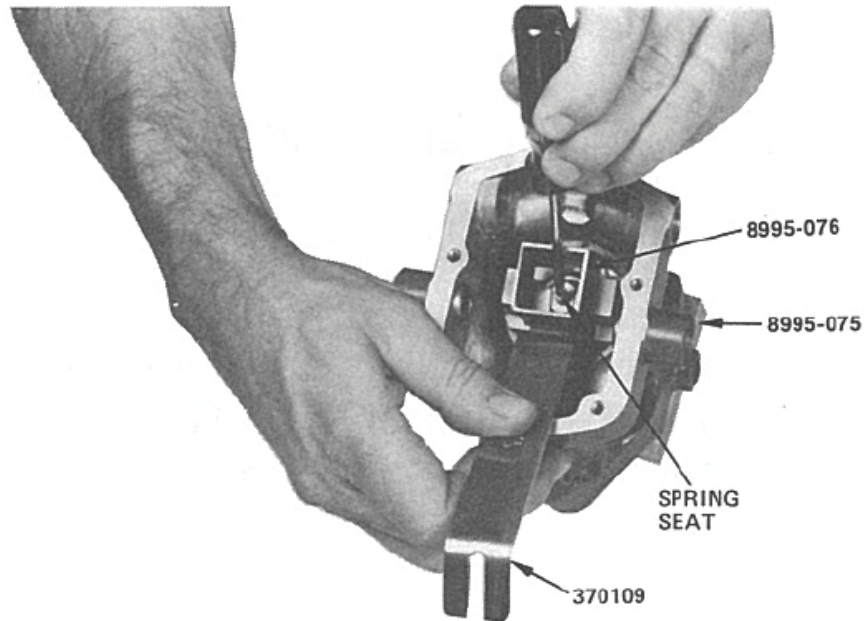

Figure 3-21. Centering the Pilot Valve Plunger

18. Center pilot valve plunger using tools shown in Figure 3-21.
 - a. Hold spring seat with wrench (370109) and set block 8995-076 between flyweights.
 - b. Press down on spring seat (40) with plunger wrench. This forces flyweights inward to hold block 8995-076 suspended between the flyweights.
 - c. Turn plunger cw with a screwdriver slowly until pilot valve plunger contacts spacer 8995-075 and block just drops down on spring seat.
 - d. If the ballhead is the solid type (not spring driven—oil damped), turn the plunger an additional 3/4 turn clockwise. Turn the nut down onto spring seat and torque to 70 lb-in (7.9 N·m). See Figure 3-22.
 - e. If the ballhead is the oil damped type, do not perform Step D. Instead, after following step C, turn the nut down onto the spring seat and torque to 70 lb-in (7.9 N·m).

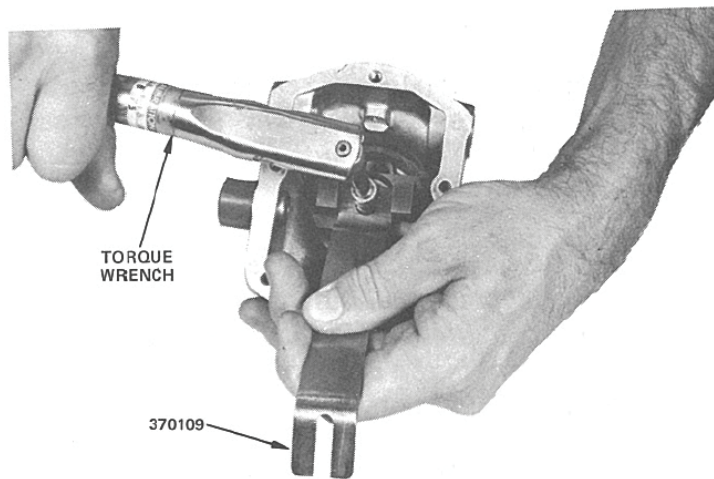

Figure 3-22. Torquing Lock Nut

Alternate Method of Centering Pilot Valve Plunger

Check the centering of the pilot valve plunger by removing plug (77) and, looking through the plug hole observe the pilot valve plunger through the control port as shown in Figure 3-23.

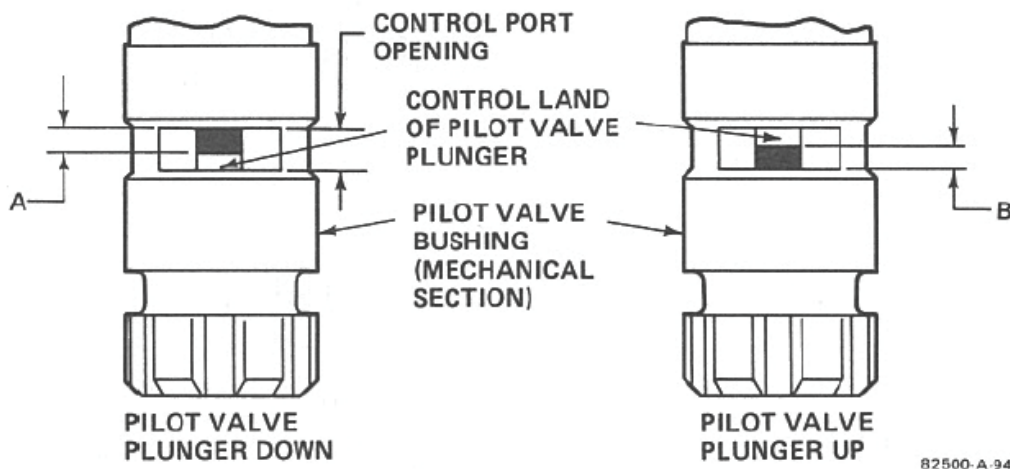

Figure 3-23. Centering Pilot Valve Plunger

Push on the flyweight toes to lower the pilot valve plunger (PVP) as far as possible. Check distance "A". Pivot flyweights out as far as possible and check distance "B". Distance "A" must equal distance "B" when flyweights have been moved from their extreme inward to their extreme outward position. See Figure 3-23.

If the PVP is too low, use pilot valve wrench (370109) to hold spring seat (40) stationary, and turn PVP counterclockwise to raise it. If the PVP is too high, hold spring seat and turn PVP clockwise to lower it.

When pilot valve plunger is centered, tighten nut (41, Figure 3-20) by torquing it to 70 lb-in (7.9 N·m).

19. Install speeder spring on spring seat. Place tool 370109 under spring seat (40) and force the spring seat upwards and at the same time place speeder spring (42) on top of spring seat. Hold spring seat (40) and push spring (42) down and turn cw to secure it on spring seat. See Figure 3-24.

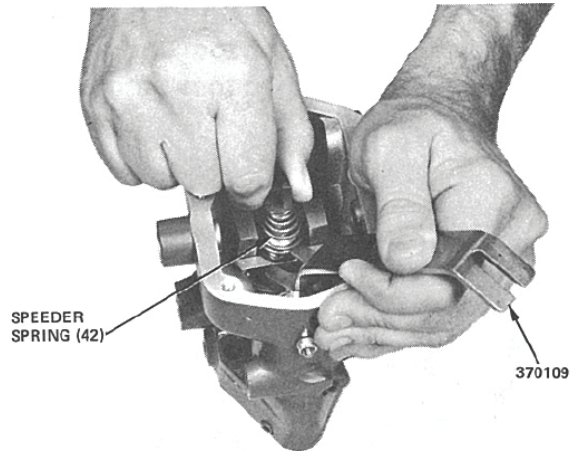

Figure 3-24. Speeder Spring Installation

20. Assemble speed droop bracket, terminal lever, and terminal shafts into case. See Figures 3-25 and 3-26.

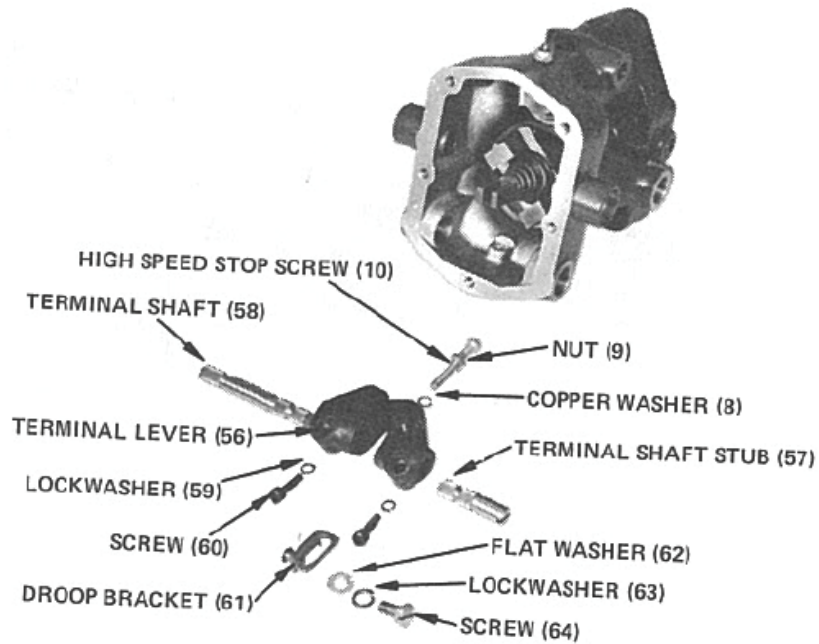

Figure 3-25. Terminal Lever & Terminal Shaft Parts Layout

21. Assemble droop bracket to terminal lever per Figure 3-26, but do not tighten screw (64).

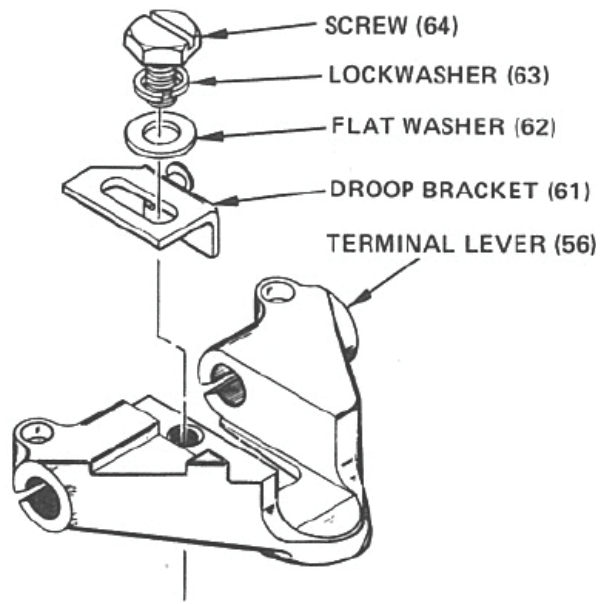

Figure 3-26. Droop Bracket Assembly

22. Align droop bracket (61) to zero droop. Use tool 8995-085 as shown in Figure 3-27 and align droop bracket pin with end of tool. Tighten screw (64).

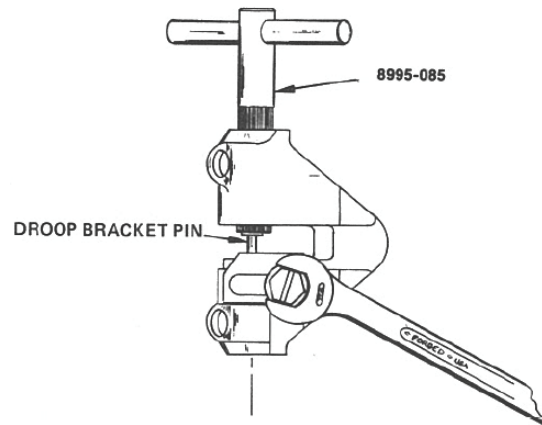

Figure 3-27. Setting Zero Droop

23. Assemble high speed stop screw (10), nut (9), and washer (8) into case (1).
24. Figure 3-28 shows the speed adjusting parts layout.
- Assemble lever (51) on shaft (52) and secure with pin (53). Position pin (53) and lever (51) as shown in Figure 3-28.
 - Insert shaft (52) through hole in case from the inside of case.
 - Place copper washers (48) on spacer caps (49 and 50) and insert them into case and tighten with a torque wrench to 30 lb-ft.
 - Position floating lever (55) with its slot straddling the droop bracket pin. Be sure 450 notch is on top.
 - Align holes in floating lever (55), adjusting lever (51) and speeder spring fork (42) and secure together with wire pin (54).
 - Bend wire pin (54) with tool 8995-078 as shown in Figures 3-29 and 3-30.

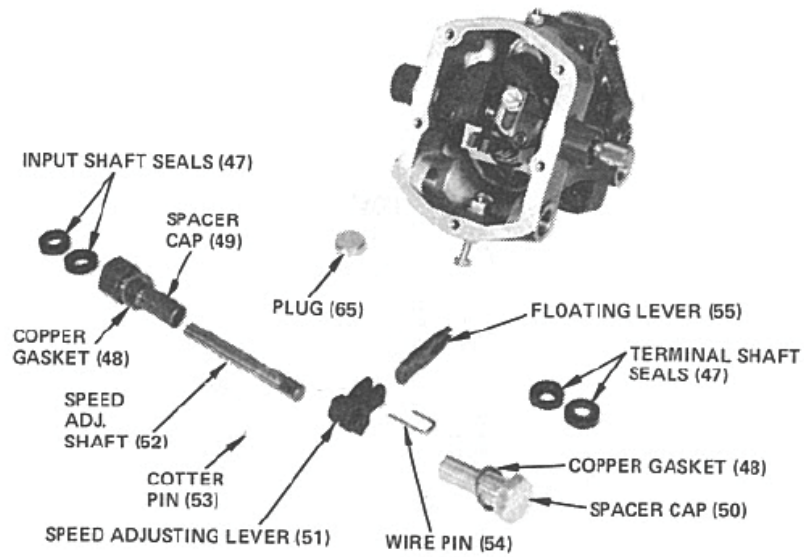

Figure 3-28. Speed Adjusting Parts Layout

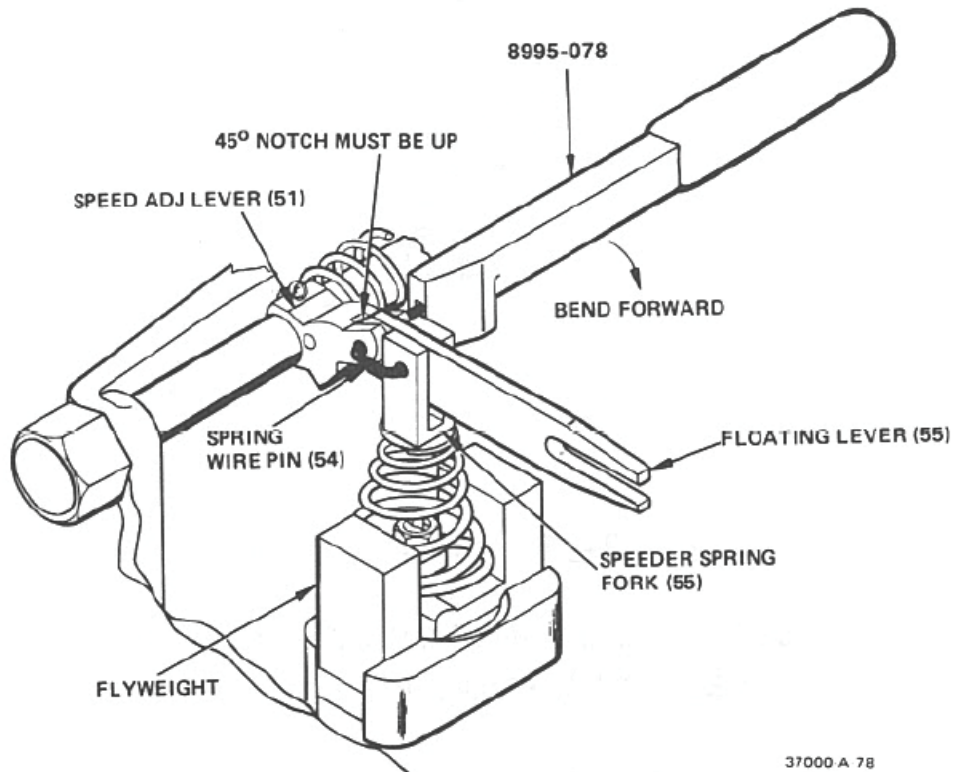

Figure 3-29. Speed Adjusting & Floating Lever Assembly

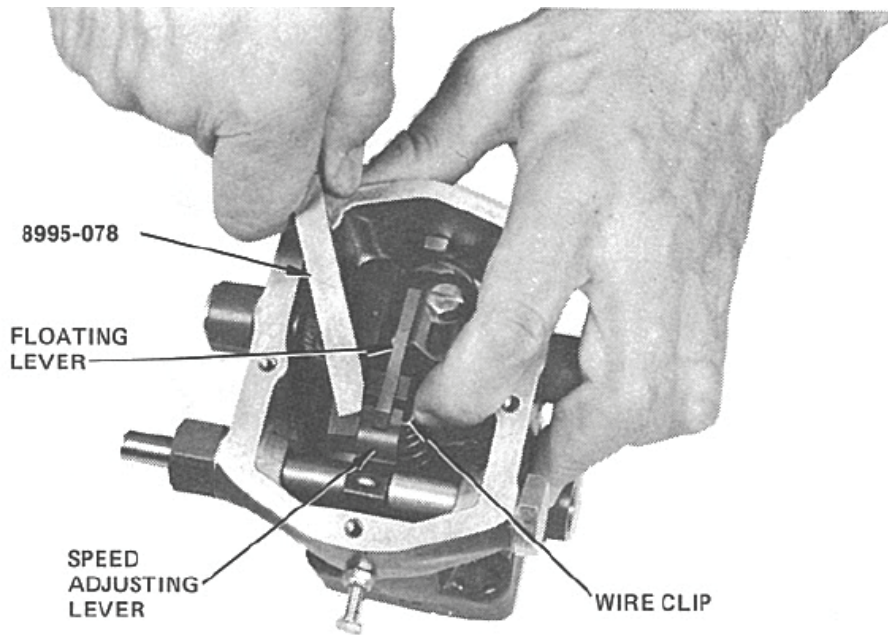

Figure 3-30. Bending Spring Wire Pin

25. Place tool 8995-079 on terminal shaft (58) and slide seals (47) onto tool with cups of seals facing each other. Press seals (47) into bushing (46) with seal installation tool until seated. See Figure 3-31.

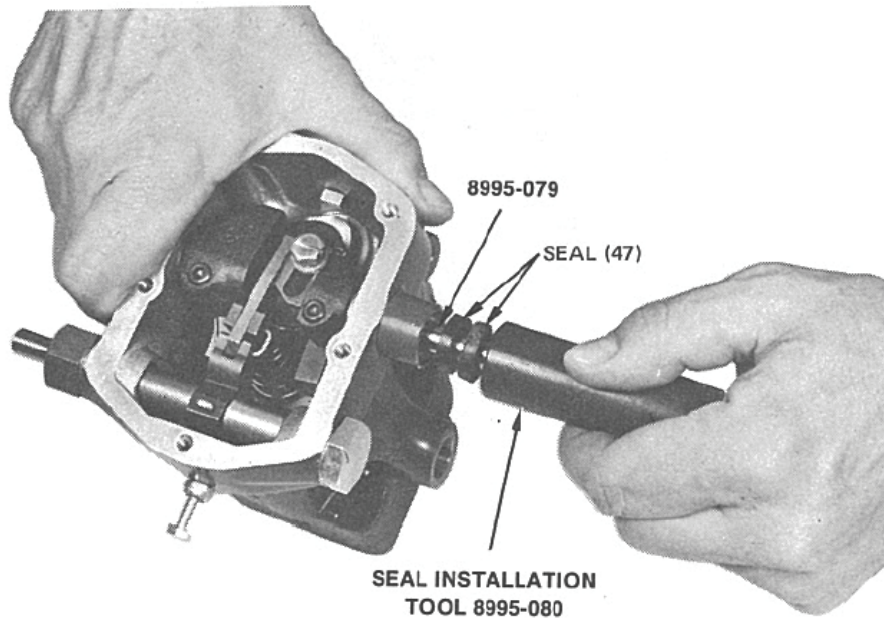

Figure 3-31. Seal Installation

26. Install seals on speed adjusting shaft (52) the same way as on the terminal shaft.

27. Install Welch plug (65) on the side with stub terminal shaft (57). On governors with terminal shaft extending from both sides, the Welch plug is omitted. See Figure 3-32.

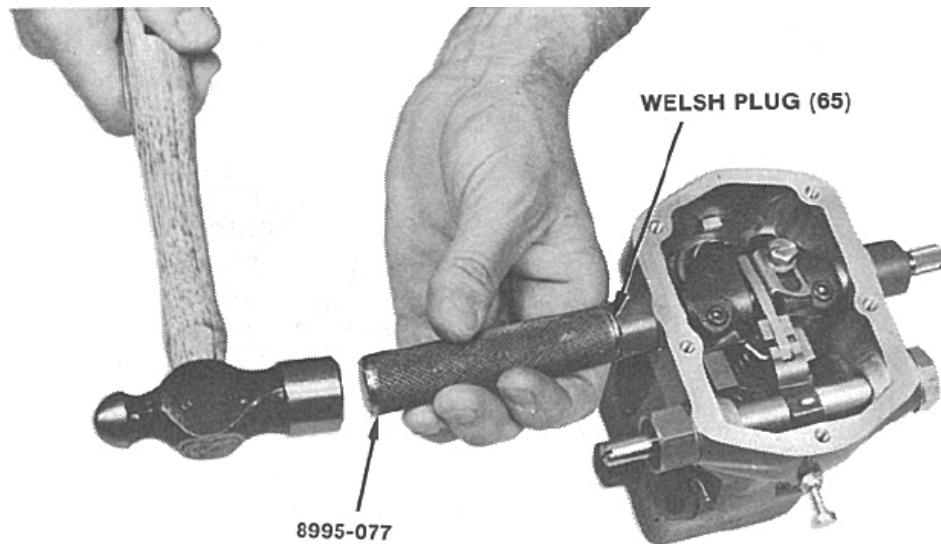

Figure 3-32. Welch Plug Installation

IMPORTANT

See Figure 3-33 for following steps 28 through 31.

28. Install relief valve assembly (17 through 22) into case (1) and tighten.
29. Lubricate O-ring (7) with petrolatum and put it on needle valve (6). Thread needle valve into case until it is flush with case boss.
30. Assemble vent screw (72) and copper washer (73) in cover.
31. Assemble low speed stop screw (68) and lock nut (69) in cover.

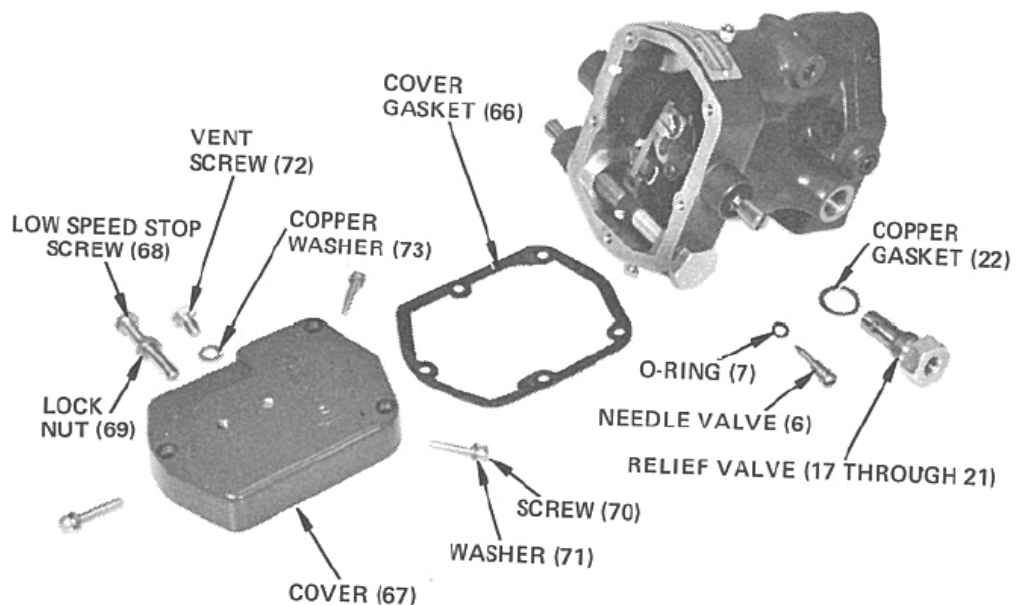

Figure 3-33. Final Assembly of Relief Valve, Needle Valve, & Cover

32. Position gasket (66) on top of case (1) and secure cover (67) to case with screws (70) and washers (71).

Testing

It is important to test the governor, either on a test stand or on the engine it operates on.

The tools listed in Table 3-3 are optional and, unless a large amount of governors are being repaired, are not absolutely necessary. If accurate tests are to be run on governors, contact Woodward and obtain a copy of the test specification for each particular governor.

If adequate test facilities are not available, make minor tests before and after installation on the engine.

Before installation, check that there is no negative droop by attaching a dial indicator to the governor case so the indicator rod rides on top of the floating lever (55, Figure 4-1) and above the pilot valve plunger (31). Rotate the terminal lever from minimum to maximum fuel position and observe the dial to see whether or not there is movement of the floating lever. No movement of the indicator is zero droop. Upward movement of lever (55) is positive droop. Check the final droop setting with the governor operating on the engine. Only zero droop (isochronous operation) or positive droop is allowed. If the bracket is set on a previously scribed line, droop should be very close to the correct amount.

Reset low and high speed stop screws to pre-measured settings. After installation on the engine and with all linkages correctly installed, start the engine.



Be prepared to make an emergency shutdown when starting the engine, turbine, or other type of prime mover, to protect against runaway or overspeed with possible personal injury, loss of life, or property damage.

Assuming that everything is operating properly, let the governor hunt for about a minute. This allows air to bleed out of the oil passages. Close the needle valve to a torque of 6 lb-in (0.7 N·m). Back the needle valve out 1/16 to 1/8 of a turn to provide optimum performance.

Check that the correct amount of droop is set and if necessary, readjust the droop bracket.

Table 3-3. Tools Required for Testing

Tool Description	Number	Application
Hydraulic Test Stand	8909-045	Drives governor, supplies oil under pressure. Contains gauges for monitoring governor operation and electronic counter.
Adapter Kit	6995-628	Permits testing of PSG governors on test stand.

Chapter 4. Replacement Parts

Replacement Parts In Formation

When ordering replacement parts, it is essential to include the following information:

- Governor serial number and part number shown on nameplate.
- Manual number (this is manual 37013).
- Parts reference number in parts list and description of part or part name.

Illustrated Parts Breakdown

The illustrated parts breakdown lists all the replaceable parts for the PSG. The numbers assigned are used as reference numbers and are not specific Woodward part numbers. Woodward will determine the exact part number for your particular governor.

Ref. No.	Part Name	Quantity
37013-1	Case	1
37013-2	Soc. hd. plug, 1/16 NPTF	1
37013-3	Power piston stop screw	1
37013-3A	Bushing stop	1
37013-4	Copper washer, 0.203 I.D.	1
37013-4A	Thread seal	2
37013-4B	Washer #10	2
37013-5	Elastic stop nut, 10-32	1
37013-5A	Jam nut, 10-32	1
37013-6	Needle valve	1
37013-7	O-ring	1
37013-8	Copper washer, 0.203 I.D.	1
37013-9	Elastic stop nut, 10-32	1
37013-10	High speed stop screw, 10-32 X 1.50 in. 1	
37013-11	Retaining snap ring	1
37013-12	Buffer spring seat	1
37013-13	Buffer spring	1
37013-14	Buffer piston	1
37013-15	Buffer spring	1
37013-16	Power piston	1
37013-17	Relief valve sleeve	1
37013-18	Pin	1
37013-19	Spring	1
37013-20	Relief valve plunger	1
37013-21	Relief valve stop sleeve	1
37013-22	Relief valve gasket	1
37013-23	Base	1
37013-24	Soc. hd. pipe plug, 0.125 inch	1
37013-25	Dowel pin	2
37013-26	Directional plug	2
37013-26A	Check Valve (optional)	4
37013-27	O-ring	2
37013-28	Idler gear	1
37013-29	Idler gear stud	1
37013-30	Pilot valve bushing	1
37013-31	Pilot valve plunger	1
37013-32	Compensating bushing	1
37013-33	Retaining snap ring	1
37013-34	Ballhead	1
37013-35	Flyweight	2

Ref. No.	Part Name	Quantity
37013-36	Pin	2
37013-37	Retaining ring	1
37013-38	Spirolox ring, 2.00 inch 10	1
37013-39	Thrust bearing	1
37013-40	Spring seat	1
37013-41	Pilot valve plunger nut	1
37013-42	Speeder spring assembly	1
37013-43	Drive screw, #2 X 0.125	2
37013-44	Nameplate	1
37013-45	Terminal shaft sleeve (see Note)	1
37013-46	Terminal shaft sleeve (see Note)	1
37013-47	Oil seal, 0.762 O.D.	4
37013-48	Copper washers	2
37013-49	Spacer sleeve	1
37013-50	Spacer cap	1
37013-51	Speed adjusting lever	1
37013-52	Speed adjusting shaft	1
37013-53	Cotter pin	1
37013-54	Spring wire pin	1
37013-55	Floating lever (speed droop lever)	1
37013-56	Terminal lever	1
37013-57	Stub shaft	1
37013-58	Terminal shaft	1
37013-59	Lock washer, #10 high collar	2
37013-60	Socket hd. cap screw, 10-32 X 0.625	2
37013-61	Droop adj. bracket	1
37013-62	Flat washer	1
37013-63	Lockwasher	1
37013-64	Hex hd. screw	1
37013-65	Welch, tapered plug, 0.750	1
37013-66	Cover gasket	1
37013-67	Cover	1
37013-68	Low speed stop cap screw, 0.250-28 X 1.750	1
37013-69	Hex hd. jam nut, 0.250-28	1
37013-70	Fillister screw, 10-32 X 1.000	3
37013-71	Split lock washer, #10	3
37013-72	Hex screw, 0.250-28 X 0.375	1
37013-73	Washer, 0.265 X 0.500 X 0.031	1
37013-74	Oil seal ring	1
37013-75	Splitlock washer, 0.250	3
37013-76	Soc. hd. screw, 0.250-20 X 1.000	3
37013-77	Soc. hd. pipe plug, 0.125 in.	1

IMPORTANT

Terminal shaft sleeves (bushings) 45 and 46 can be purchased separately. Installation requires alignment and maybe some reaming. However, when case 1 is purchased, bushings 45 and 46 are already installed in the case.

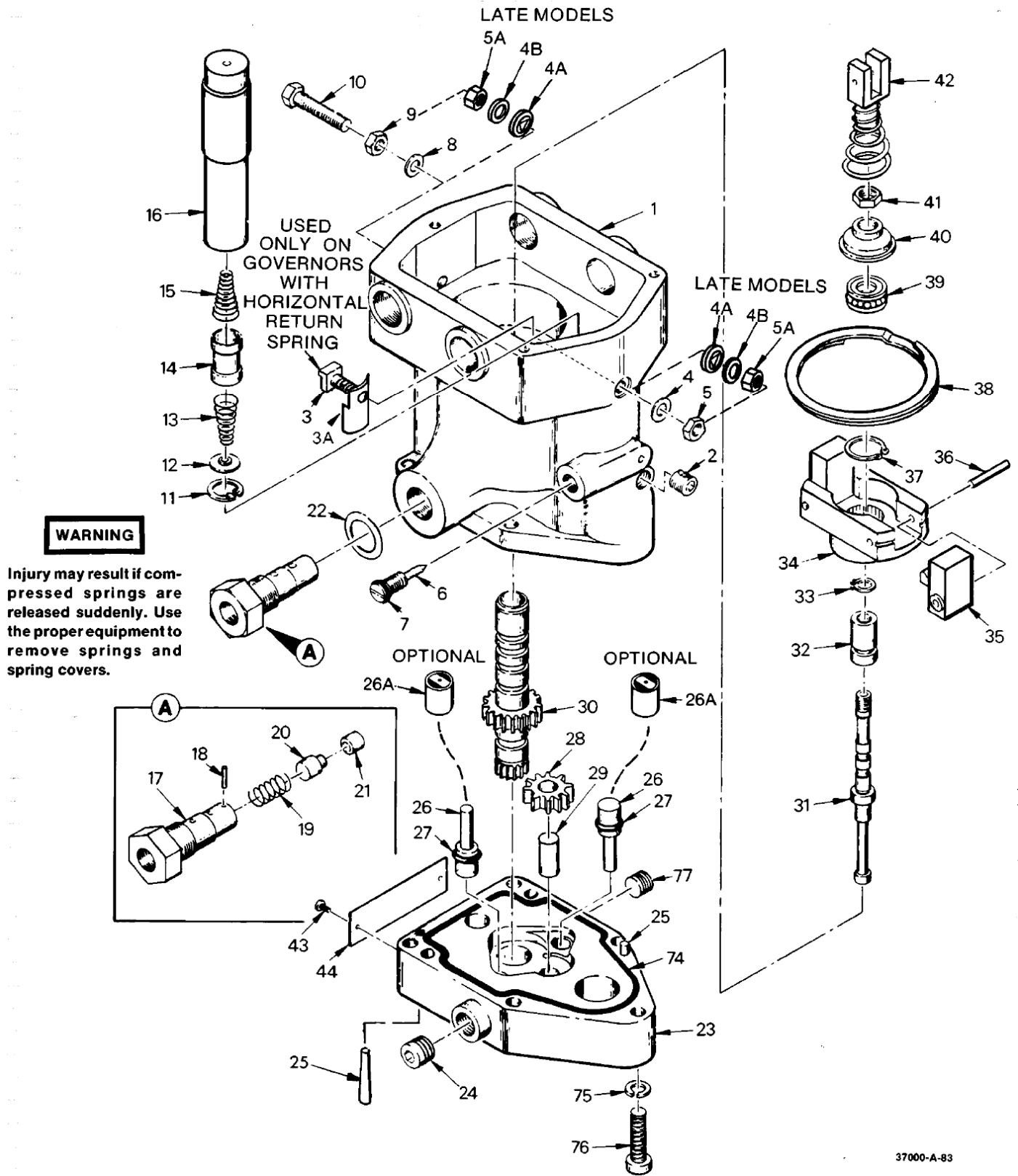

Figure 4-1a. Exploded View of PSG Governor (sheet 1 of 2)

Chapter 5.

Auxiliary Equipment

Introduction

This chapter covers auxiliary equipment that your governor may have. Using this chapter in conjunction with the other chapters in this manual provides instruction and parts for most PSGs. This chapter contains information for:

- Spring driven-oil damped ballhead
- Torsion spring
- Pneumatic speed setting
- Electric motor speed setting
- Externally adjustable droop
- Temperature compensated needle valve
- Fuel rod
- Internal return spring (vertical or horizontal)

Spring Driven-Oil Damped Ballhead

General

A spring driven-oil damped ballhead serves as a filter for torsional vibrations that originate in the drive to the governor. It consists of a ballhead drive cup (driving element) driven from the rotating bushing, a ballhead which rests on a thrust bearing carried by the driver, and a torsion spring connecting the two.

Torsional vibrations cause relative motion between the drive cup and the ballhead. This movement is inhibited by the action of a volume of oil being forced through a relatively narrow leak path, which provides the damping action.

The ballhead fills with oil through a combination of pressure feed and centrifugal action. The fill time varies with dimensional tolerances, governor pressure, and oil viscosity. The ballhead drains down partially on shut down.

Since the feed circuit functions whenever the governor is operating, there is a continuous flow of oil through the ballhead assembly. If the supply of oil is not clean, entrained contaminants centrifuge out and accumulate in the ballhead. Eventually the oil damped ballhead assumes the characteristics of a solid ballhead. If the governor is subject to excessive dirt accumulation, consider using a separate sump system for the governor.

Ballhead Check

1. Check for dirt accumulation by holding the governor drive shaft and turning the ballhead against its internal stop. Repeat in the opposite direction. Travel should be smooth and approximately 22° in each direction. If the ballhead does not come up solidly against both stops or does not return promptly to mid position when released, remove and replace the ballhead.
2. If the cover is damaged or dished as in Figure 5-1, replace it. This is normally attributed to rough handling.

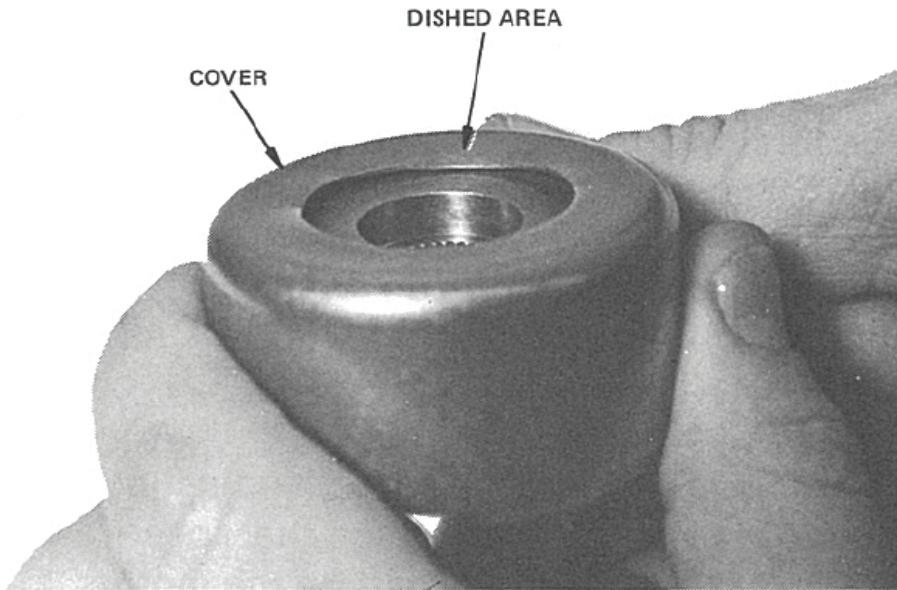

Figure 5-1. Cover Damage

3. Check that the flyweights have no flat spots on the toes and that the flyweight bearings are not worn. Also check pivot pins for wear or damage.

Parts List for Figure 5-2

IMPORTANT These parts are sold only as a complete assembly.

Ref. No.	Part Name	Quantity
37013-90	Ballhead cover.....	1
37013-91	Ballhead drive cup.....	1
37013-92	Ball bearing	1
37013-93	Torsion spring.....	1
37013-94	Flyweight pin	2
37013-95	Ballhead	1
37013-96	Flyweight	2
37013-97	Needle bearing.....	4

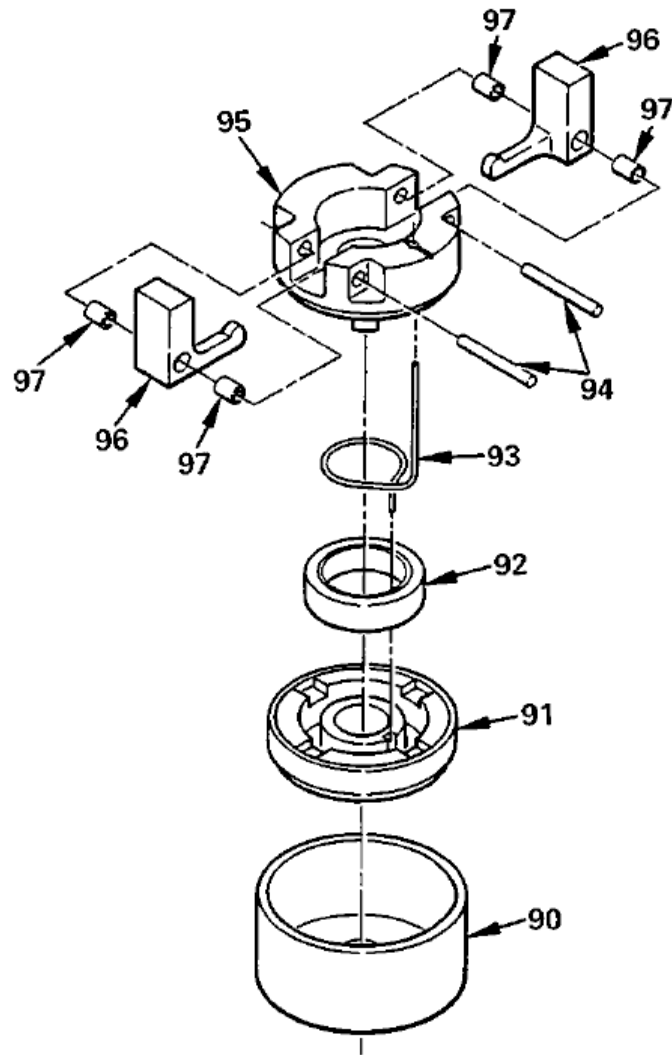

Figure 5-2. Ballhead Assembly, Exploded

Torsion Spring

The torsion spring (247, Figure 5-19) is provided on PSGs that are equipped with an electric motor for speed setting. The spring is also provided on governors that are not equipped with a speed adjusting shaft, and on governors that are operated below 800 rpm.

The spring forces the speed adjusting lever to maintain contact with either the speed adjusting screw, or the adjusting shaft on the motor.

When used with external droop the spring must mount on the speed adjusting sleeve (249), on the side opposite the speed adjusting shaft. Figure 5-15, shows a governor with left hand, externally adjustable droop, and the spring is mounted on the right side.

Pneumatic Speed Setting

Remote speed adjustment is provided through a pneumatic speed setting assembly consisting of a diaphragm, housing, oil reservoir, adjusting screws and push rod extending down through the cover to the floating lever. See Figures 5-4 and 5-5. Air signal pressure to the speed setting assembly is applied to an oil reservoir to damp out oscillations of air compression. Oil pressure acting upon the diaphragm is transmitted by the pushrod to the governor floating lever, increasing or decreasing the speeder spring force to produce a change in speed setting.

Governor operation is the same as the basic governor. Figure 5-3 shows the external view of a PSG with a pneumatic head. It also has a subcap which contains an internal, horizontal return spring.

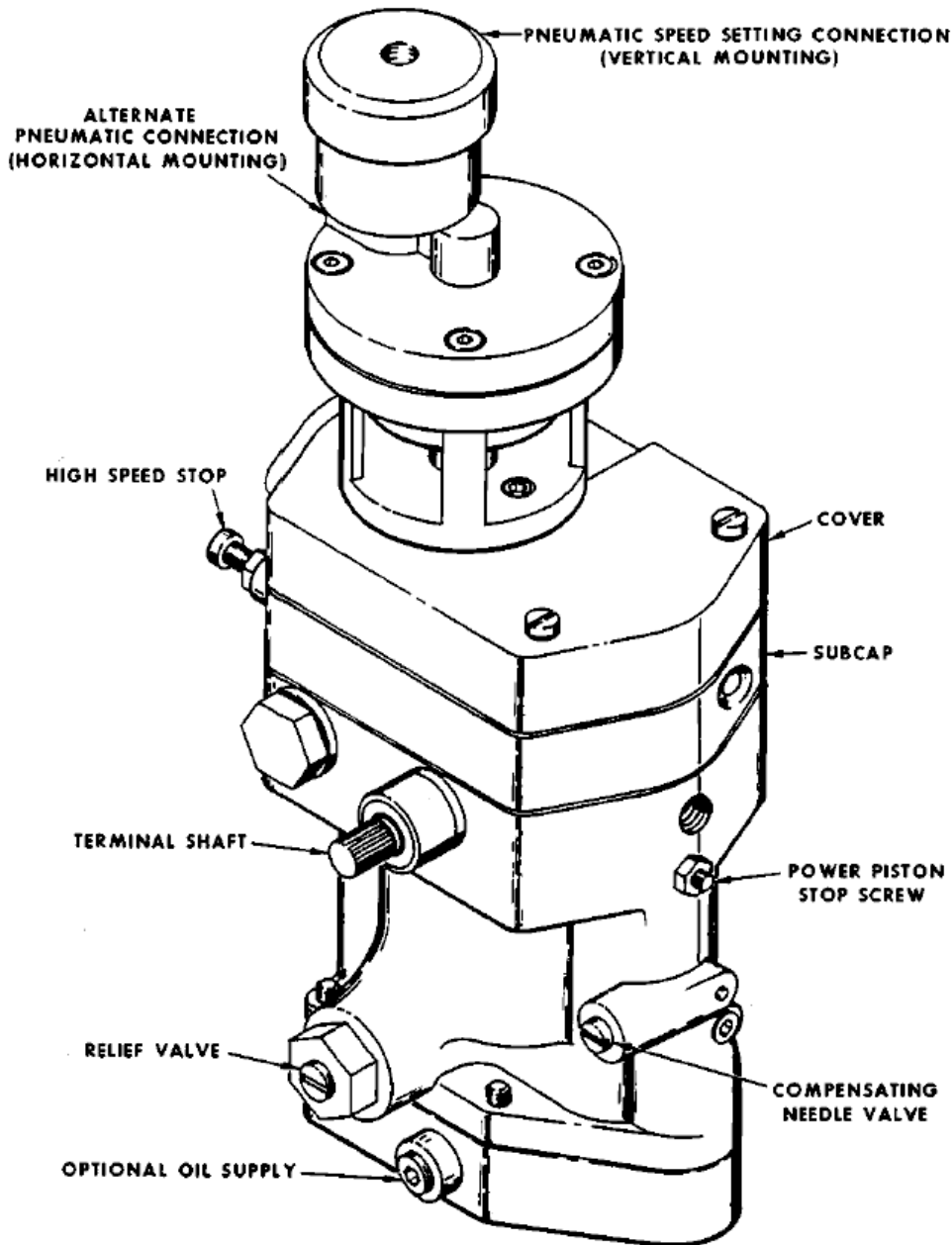

Figure 5-3. PSG with Pneumatic Head

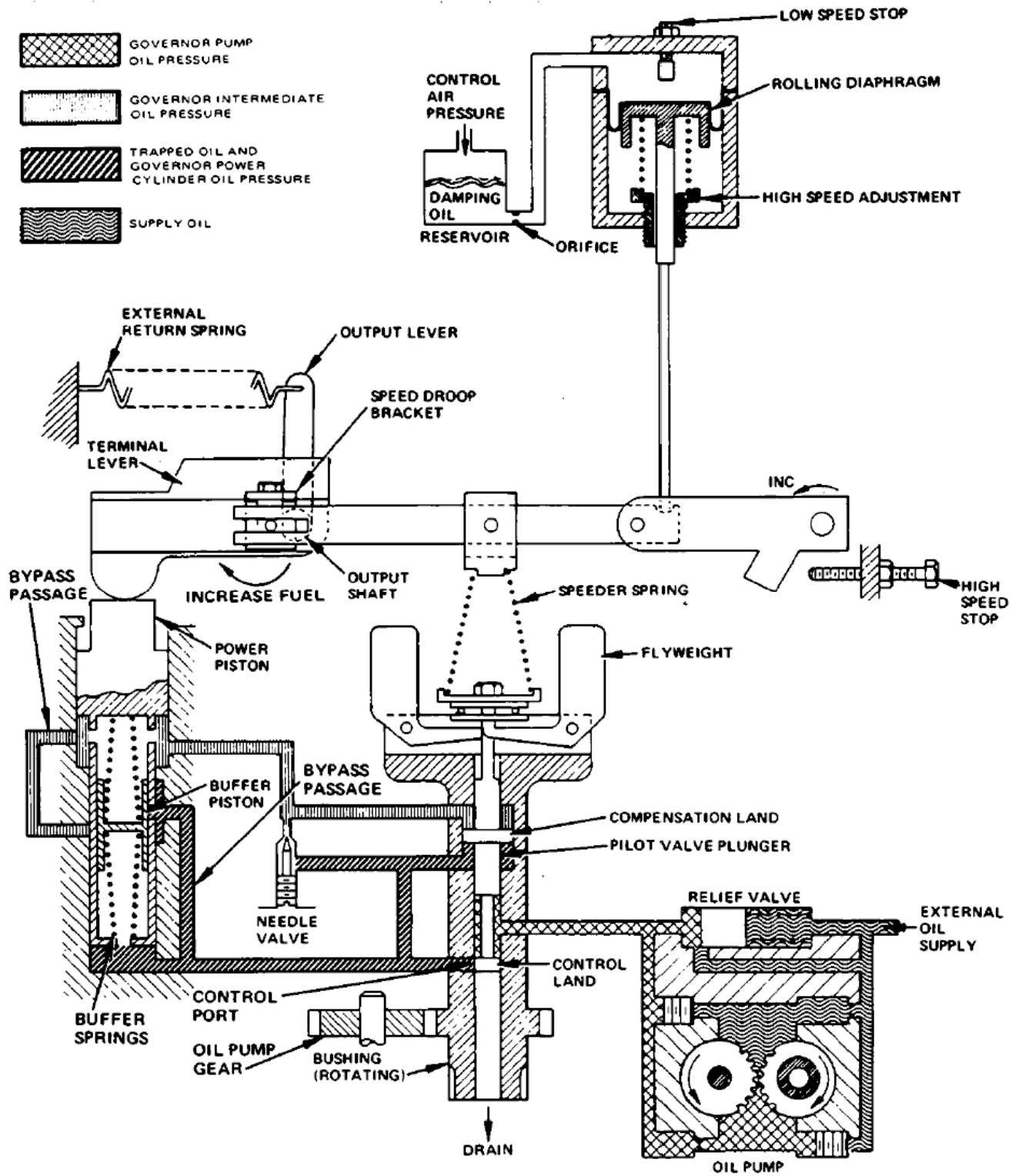
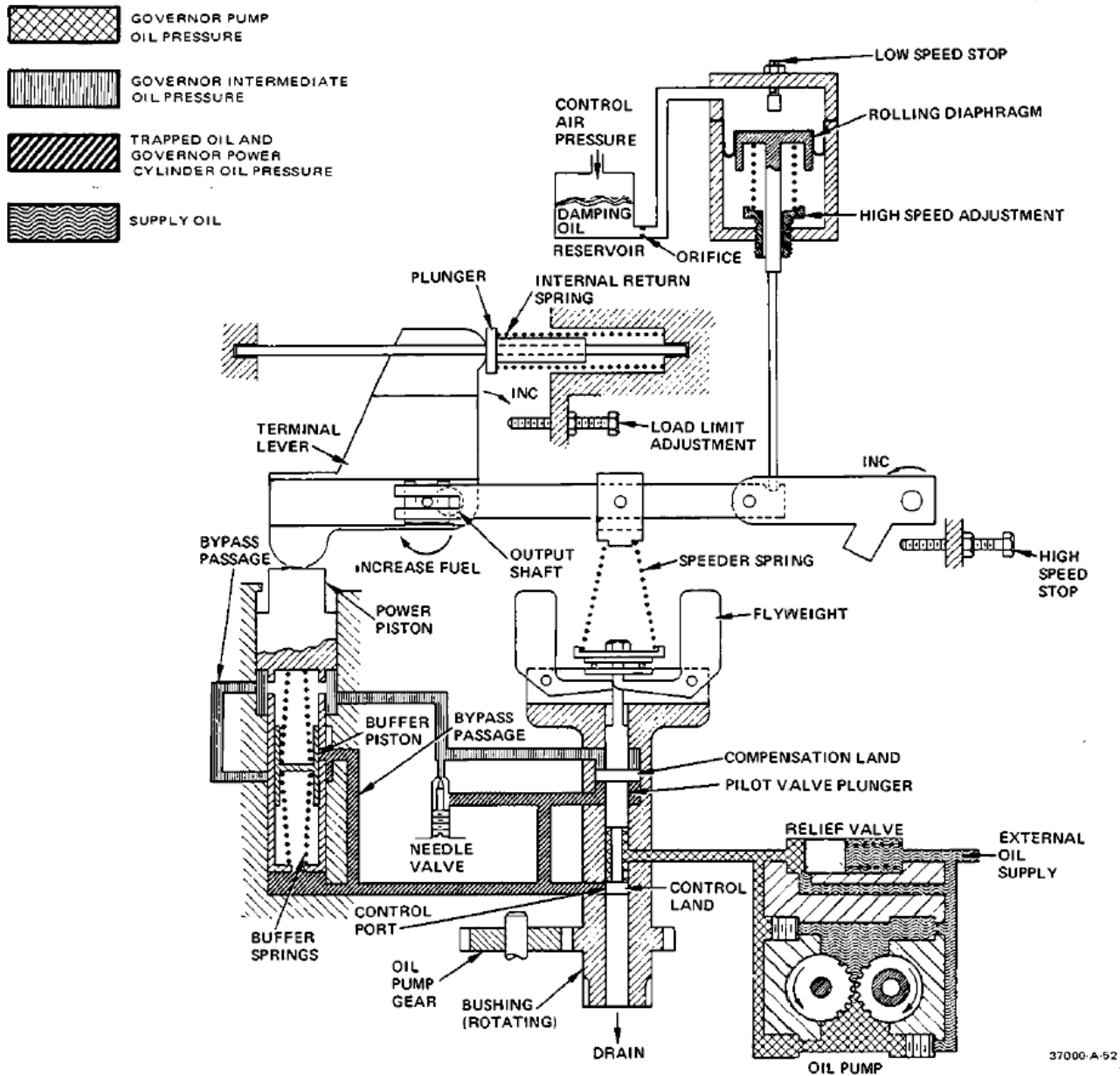

Figure 5-4. Schematic Diagram, PSG with Pneumatic Speed Setting and External Return Spring

Pneumatic speed setting is factory preset to specified minimum (idle) speed at a minimum control air pressure of typically 3 psi, and to specified rated speed at a maximum control air pressure of typically 15 psi. Field adjustment is not normally recommended.

Figure 5-4 is a schematic diagram of a PSG with external return spring and pneumatic speed setting. Figure 5-5 is also a schematic diagram showing an internal return spring on a PSG with pneumatic speed setting.

Figure 5-7 (Schematic Diagram) and Figure 5-8 (Exploded View) are sealed pneumatic heads. Figure 5-9 is an exploded view of an unsealed pneumatic head. Refer to Figure 5-7,5-8 or 5-9 if disassembly or assembly is required. Exploded views Figures 5-8 and 5-9, have the parts numbered in order of disassembly. In an overhaul or repair situation, the main parts that may need replacement are the belloram seals, rolling diaphragm3 springs and all O-rings.



37000-A-52

Figure 5-5. Schematic Diagram, PSG with Pneumatic Speed Setting & Horizontal Return Spring

When assembling a governor with pneumatic head, position the floating lever as shown in Figure 5-6. The edge with the 45° angle must be down and the indicated hole must be on top.

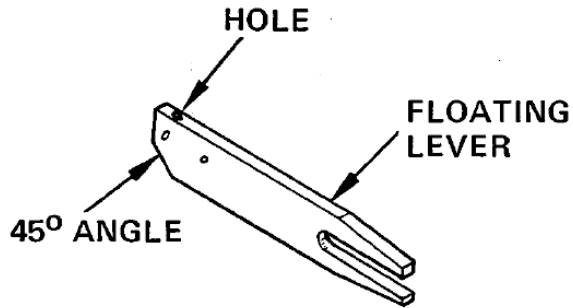

Figure 5-6. Floating Lever Assembly

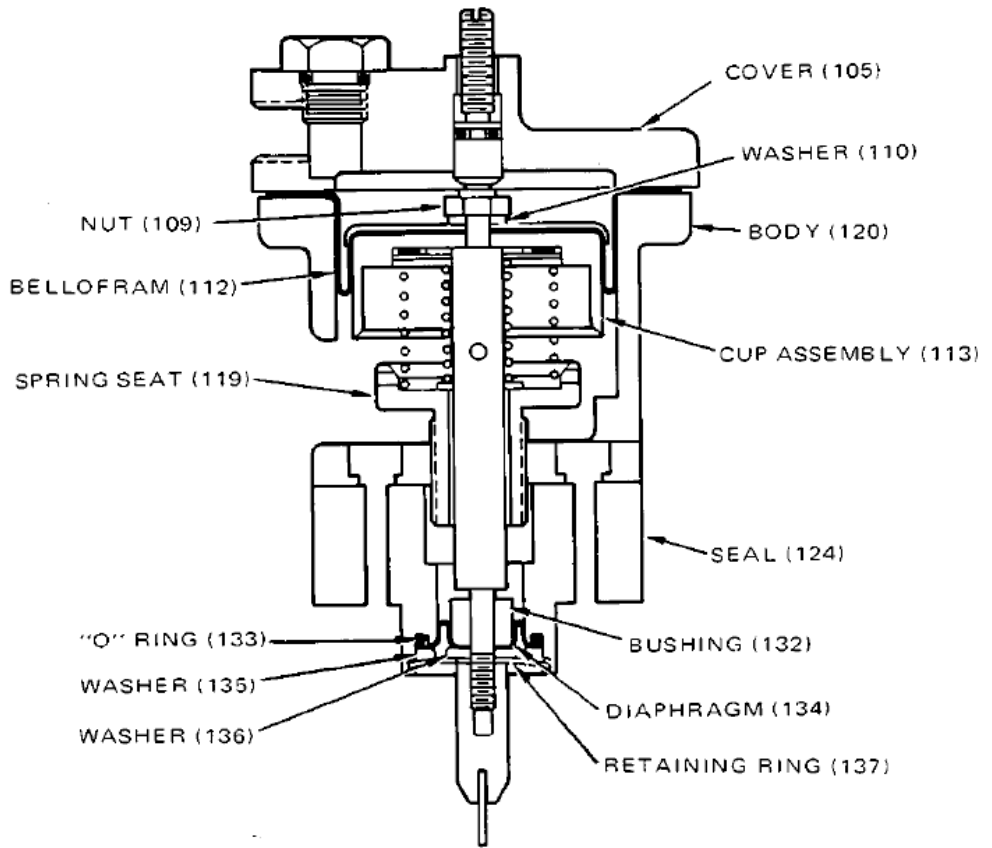

Figure 5-7. Schematic of Diaphragm & Bellofram on Pneumatic Speed Setting Assembly

Parts List for Figure 5-8

Ref. No.	Part Name	Quantity
37013-101	Accumulator assembly.....	1
37013-102	#4 DL plug.....	1
37013-103	O-ring 0.500 O.D.....	2
37013-104	Adjustment screw.....	1
37013-105	Cover assembly, bellofram.....	1
37013-106	Screw, 10-32 X 0.750 hex hd.....	4
37013-107	Washer, #10 splitlock.....	4
37013-108	O-ring 0.203 I.D., 0.343 O.D.	1
37013-109	Nut, #10-32	1
37013-110	Washer, 0.203 I.D.	1
37013-111	Plate retainer.....	1
37013-112	Bellofram seal	1
37013-113	Bellofram cup assembly.....	1
37013-114	Needle thrust bearing.....	1
37013-115	Washer, 1.250 O.D.	1
37013-116	SGX pneumatic speed setting spring.....	1
37013-117	Shutdown plunger spring	1
37013-118	Washer, 0.625 O.D.	1
37013-119	Spring seat.....	1
37013-120	Speed adjustment body	1
37013-121	Nut, 10-32 Greer self-locking	2
37013-122	Nylon plug.....	1
37013-123	Nyloc set screw 8-32 X 0.50	1
37013-124	Seal retainer.....	1
37013-125	Fillister hd. screw 10-32	3
37013-126	Washer, #10 splitlock.....	3
37013-127	Not Used.....	1
37013-128	Cover	1
37013-129	Cover gasket.....	2
37013-130	Steel washer 0.203 I.D.....	2
37013-131	Cap screw 10-32.....	1
37013-132	Seal bushing	1
37013-133	O-ring	1
37013-134	Rolling diaphragm.....	1
37013-135	Diaphragm clamp washer	1
37013-136	Diaphragm clamp washer	1
37013-137	Bowed retaining ring	1
37013-138	Output rod end assembly.....	1

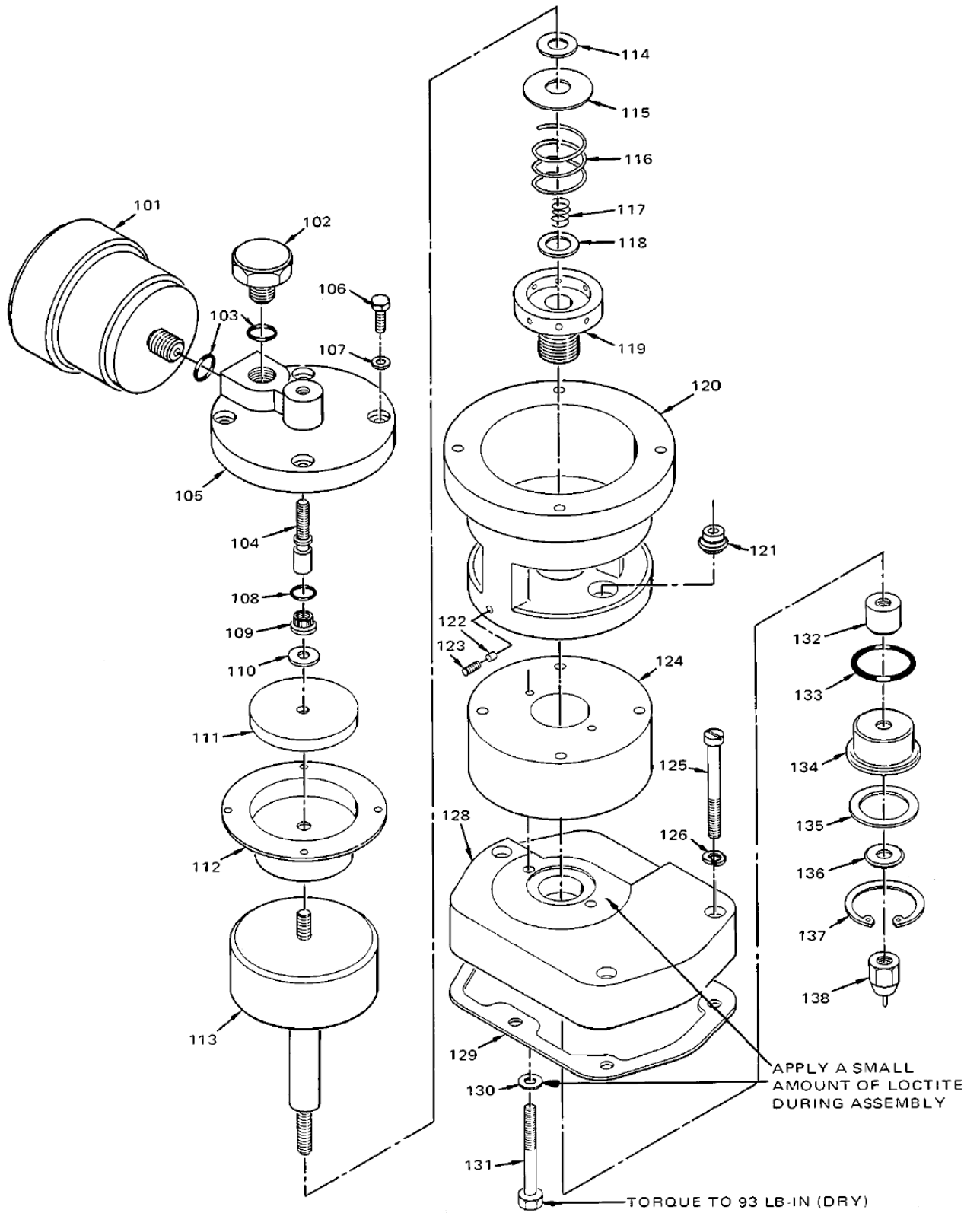

Figure 5-8. Exploded View of PSG Sealed Pneumatic Speed Setting

Parts List for Figure 5-9

Ref. No.	Part Name	Quantity
37013-151	Accumulator assembly	1
37013-152	Plug, #4 DL	1
37013-153	O-ring, 0.364 I.D. X 0.070	2
37013-154	Adjustment screw	1
37013-155	Bellofram cover assembly	1
37013-156	Screw, 10-32 X 0.750	4
37013-157	Splitlock washer, #10	4
37013-158	O-ring, 0.208 I.D. X 0.070	1
37013-159	Kaylok nut, 10-32	1
37013-160	Washer, 0.203 X 0.438 X 0.064 thick	1
37013-161	Retainer plate	1
37013-162	Bellofram seal	1
37013-163	Plug	1
37013-164	Nyloc set screw, 8-32 X 0.500	1
37013-165	Soc. Hd. cap screw, 10-32	2
37013-166	Steel washer, 0.203 I.D.	2
37013-167	Clinch nut, 10-32	2
37013-168	Body	1
37013-169	Pneumatic head cup assembly	1
37013-170	Bearing	1
37013-171	Washer, 1.250 O.D.	1
37013-172	Spring	1
37013-173	Spring	1
37013-174	Washer, 0.625 O.D.	1
37013-175	Spring seat	1
37013-176	Not used	1
37013-177	Drain pipe plug, 0.250 NPT	1
37013-178	Fillister hd. screw, 10-32	3
37013-179	Lockwasher, #10	3
37013-180	Cover	1
37013-181	Gasket	1

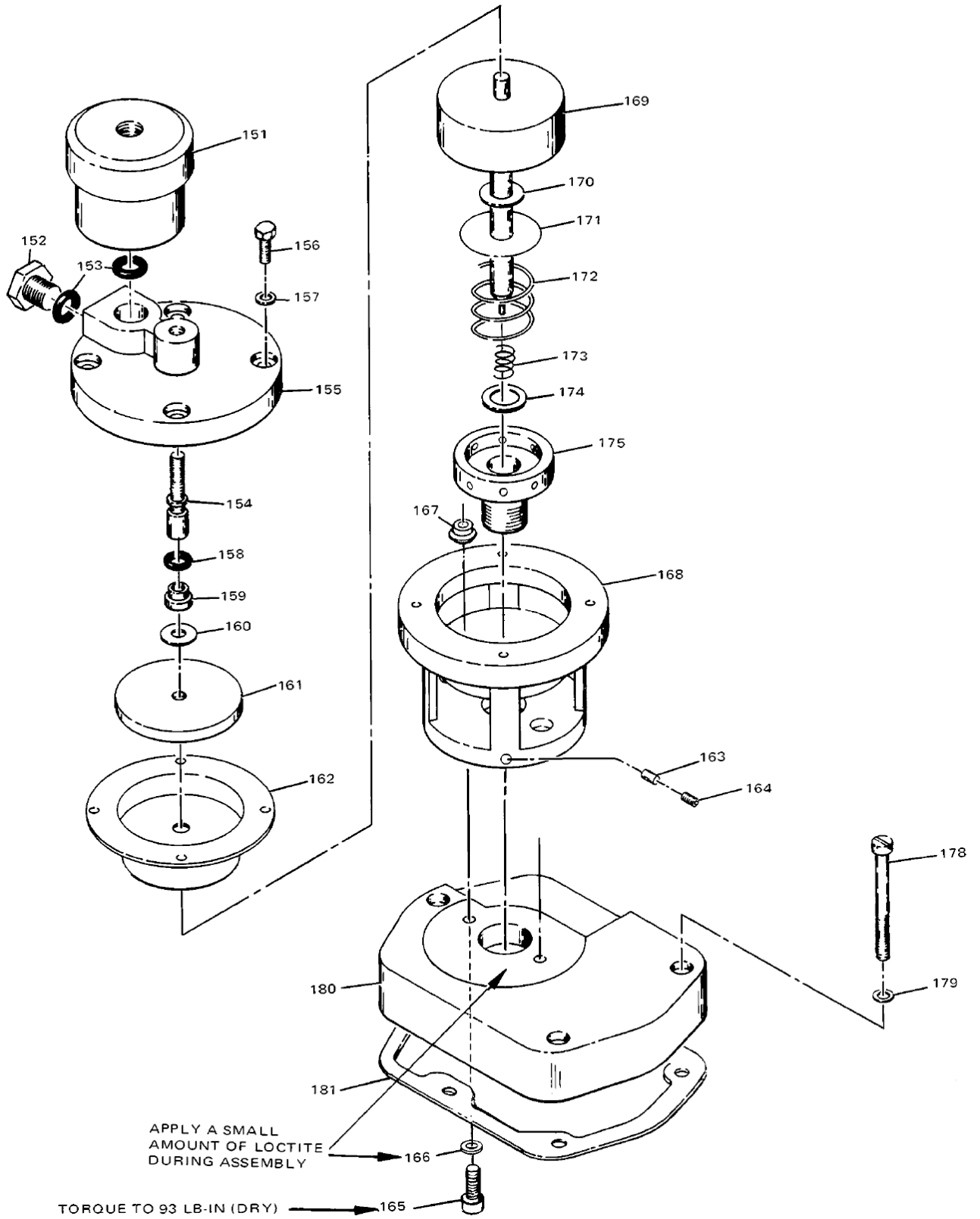

Figure 5-9. Exploded View of PSG Unsealed Pneumatic Speed Setting

NOTE: 36° MAXIMUM TRAVEL. 2/3 TRAVEL RECOMMENDED FOR NORMAL CONTROL FROM NO LOAD TO FULL LOAD. DO NOT USE LESS THAN 20° FOR CONTROL.

SUPPLY OIL SHOULD BE CLEAN LUBRICATING OIL AT A MINIMUM PRESSURE OF 5 PSI. THE OIL MAY BE TAKEN FROM ENGINE IF CAPACITY IS SUFFICIENT.

CAVITY BELOW RESERVOIR MUST BE KEPT FULL OF OIL AT ALL TIMES. AIR TRAPPED HEREIN MAY INDUCE HUNTING.

FILL AS FOLLOWS:
GOVERNORS WITH HORIZONTAL AXIS ARE SHIPPED WITH OIL RESERVOIR AS SHOWN. AFTER ASSEMBLY ON ENGINE, REMOVE RESERVOIR, FILL CAVITY WITH ENGINE OIL, REPLACE RESERVOIR, THEN FILL RESERVOIR BEFORE CONNECTING AIR LINE.

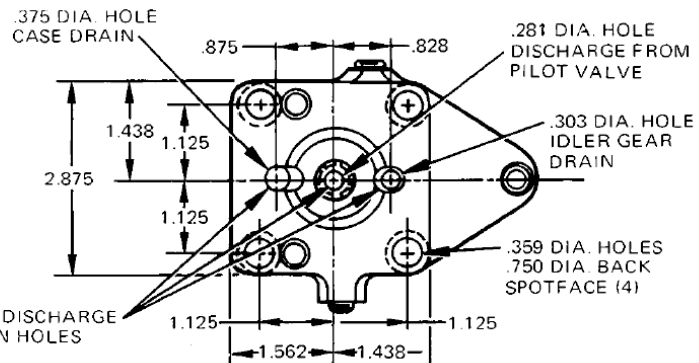
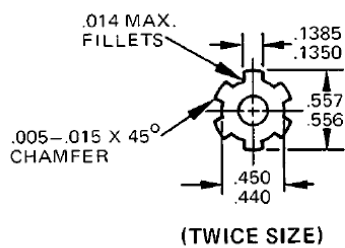
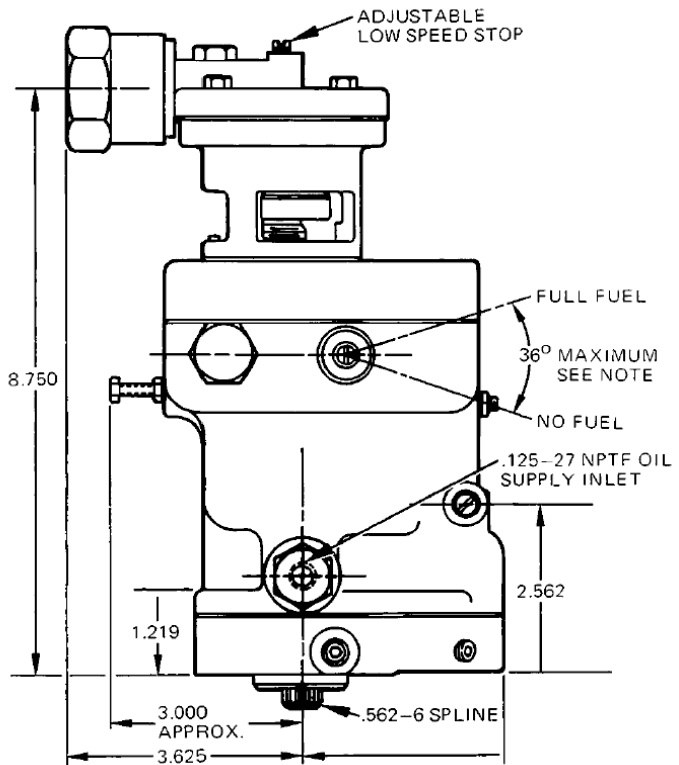
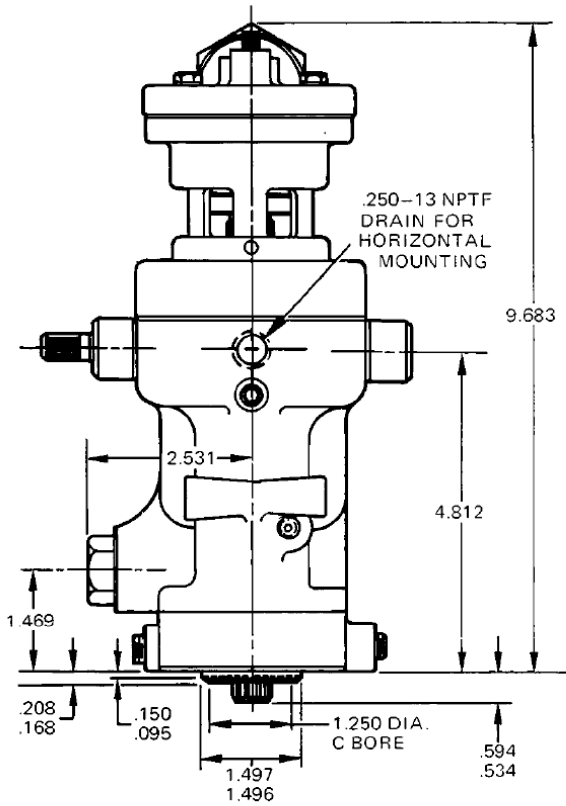
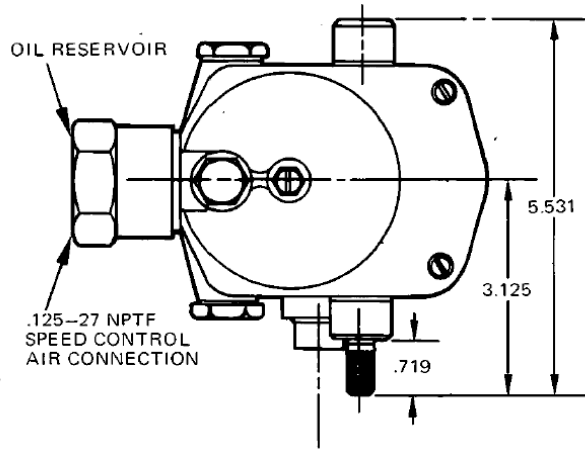

OIL MUST HAVE FREE DISCHARGE FROM THESE (3) DRAIN HOLES

37000 A-45

Figure 5-10. Outline Drawing, PSG with Pneumatic Speed Setting (Do not use for construction.)

Speed Adjusting Motor

An electric speed adjusting motor mounted on the PSG cover is used for remote adjustment of the governor speed setting. There are two types of motors available.

The Pittman motor is of the permanent magnet type 12 or 24 Vdc, see Figure 5-13. When motor supply voltage is other than 12 or 24 Vdc, the following control boxes are available for conversion to 24 Vdc:

- 24 Vdc P/N 8272-515
- 110 Vdc P/N 8272-518
- 110 Vac P/N 8272-516
- 220 Vac P/N 8272-517

The Bodine motor is of the split field, series wound, reversible type. See Figure 5-12. It is available in all standard voltages.

A manual speed adjusting knob is included on units fitted with a speed adjusting motor.

The PM motor (Figure 5-13) and the Bodine motor (Figure 5-14) are coupled to the governor speed-setting mechanism through a friction clutch. If the operator runs the speed adjustment to its limit, the clutch is set to slip, thereby protecting the speed-adjusting motor.

Connect the electric speed setting as shown in Figure 5-11 or 5-12. Figure 5-12 is for the Bodine motor and Figure 5-11 is for the PM motor. Voltage for the Bodine motor is shown on the motor.

NOTICE

The permanent magnet motor operates on dc power. If a 115 or 230 Vac power source is used, convert the power source to a 24 to 32 Vdc current. A converter can be ordered from Woodward. Connect to correct voltage.

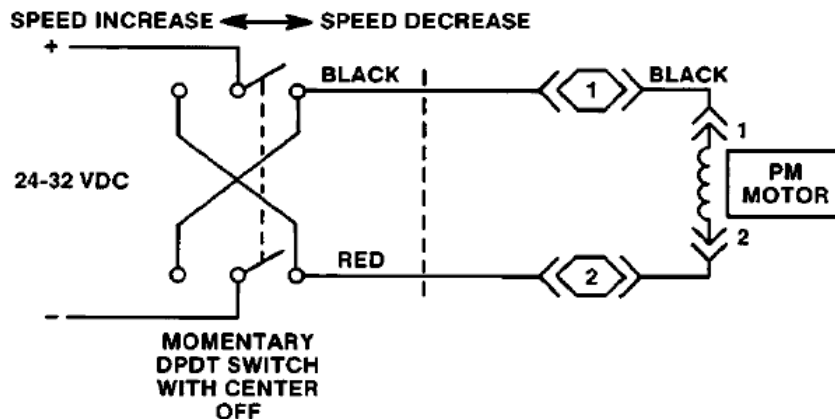

Figure 5-11. Wiring Diagram for PM Motor
(switch not furnished)

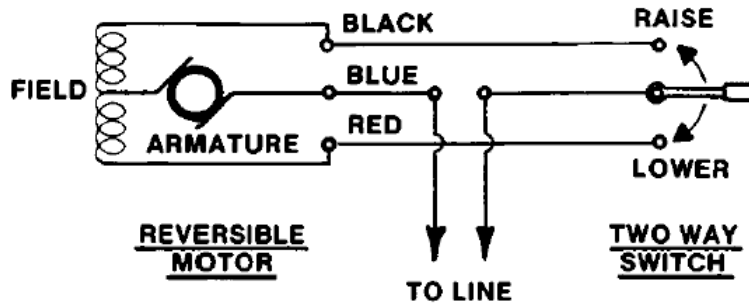

Figure 5-12. Wiring Diagram for Bodine Motor
(switch not furnished)

If the cover and PM motor are ordered separately for use on an existing governor, all that is required for the installation of the new cover is to remove the old cover before setting the new assembly in place on the governor. Some adjustment for mounting may be necessary. Loosen the screws holding the PM motor in place and align the motor shaft with the clutch. Retighten the screws.

When the cover is used without the PM motor, a screw is placed in the hole where the motor drive shaft normally fits. This screw is then used as a low-speed stop. The cover also houses a vertical return spring when one is used.

Speed Adjustment

Rotating the speed adjusting lever and shaft, using the speed adjusting motor, changes the governor speed setting. See the schematic diagram Figure 5-15 for reference.

One end of the floating lever attaches to the speed adjustment lever. The other end of the lever pivots about the speed droop pivot pin. The spring fork-speeder spring assembly connects to the floating lever. Rotating the speed adjusting lever changes the compression of the speeder spring. This changes the speed that the governor must run to develop the flyweight force necessary to balance the spring force.

Turning the speed adjusting screw, either manually by turning the knurled friction clutch or electrically by means of the speed adjusting motor, repositions the speed adjusting lever. Maximum speed setting is established by setting the high speed stop screw to limit travel of the speed adjusting lever. The motor drives the speed adjusting screw through a friction clutch which protects the motor in the event the speed adjusting lever reaches the top.

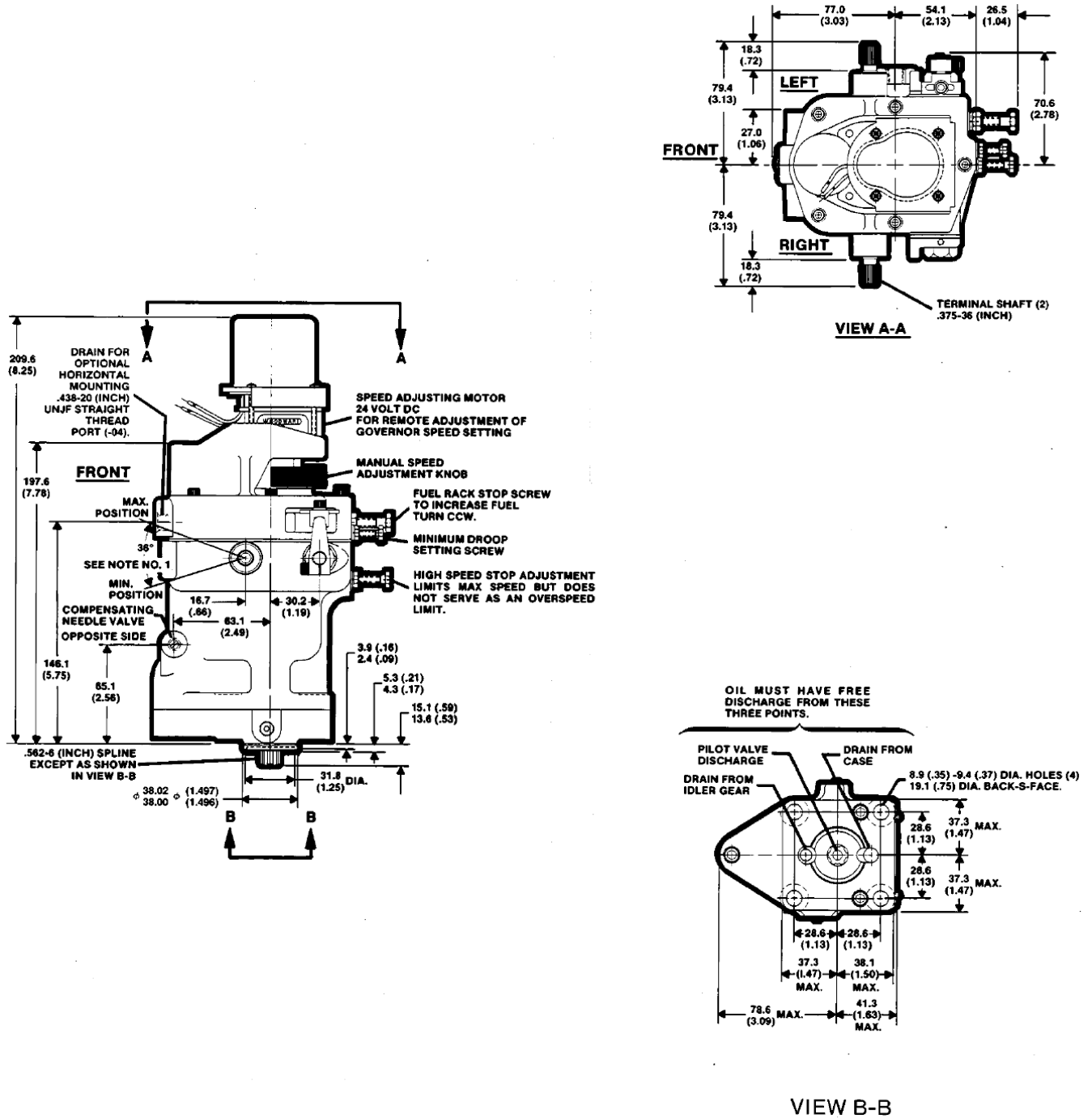

Figure 5-13. Outline Drawing, PSG with Externally Adjusted Speed Droop and PM Speed Adjusting Motor (Do not use for construction.)

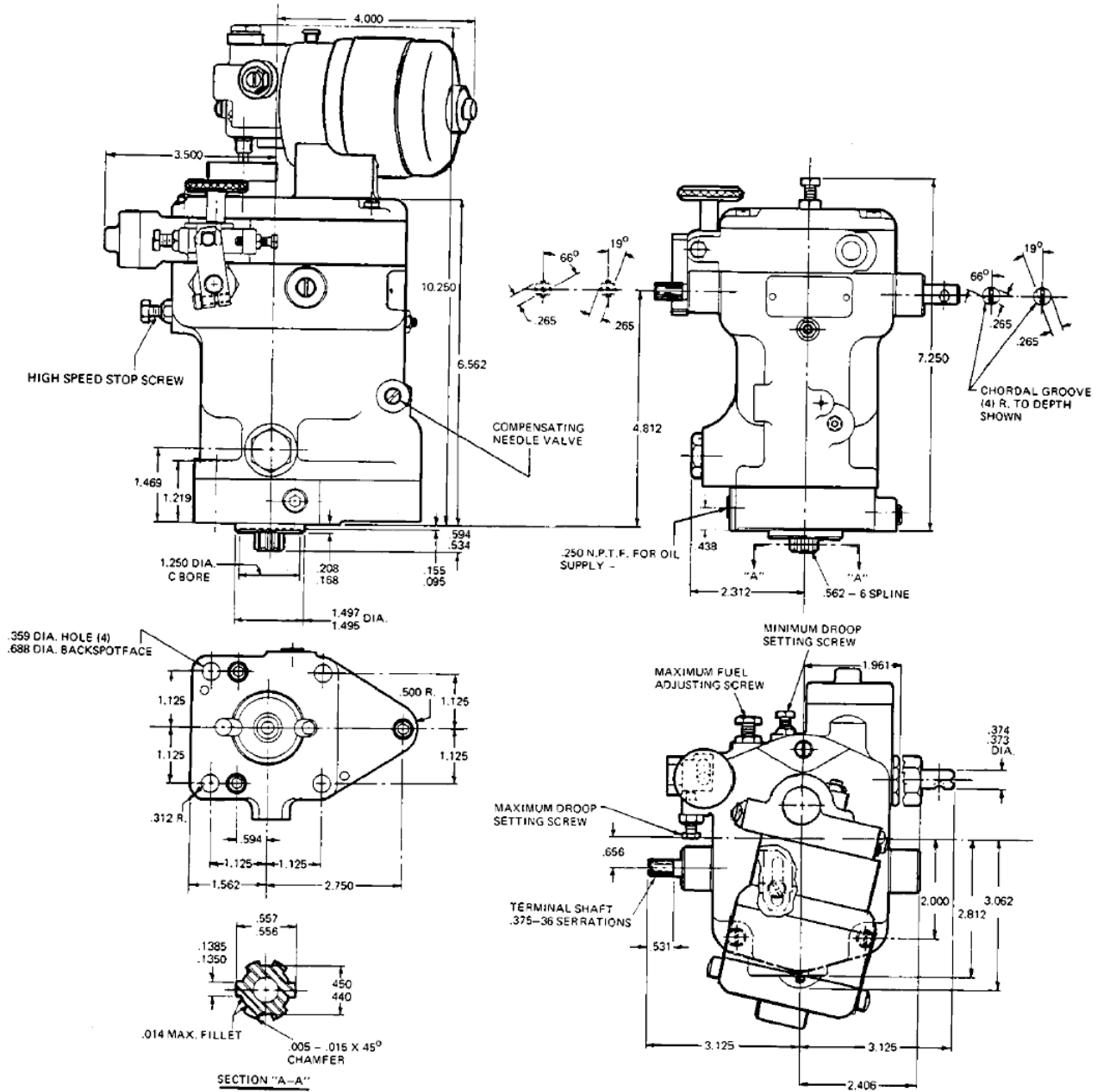

Figure 5-14. Outline Drawing, PSG with Externally Adjusted Speed Droop and Bodine Speed Adjusting Motor (Do not use for construction.)

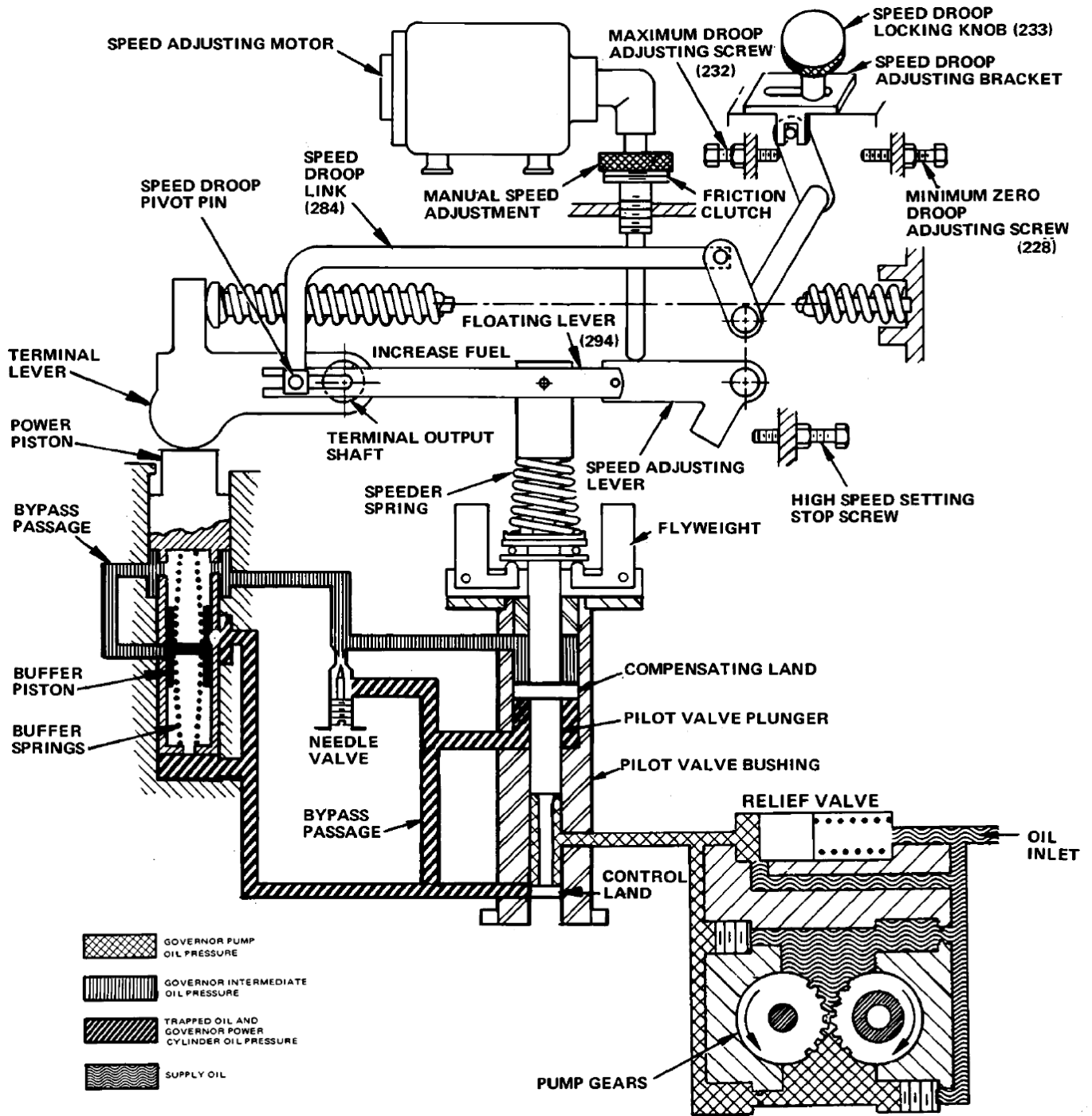

Figure 5-15. Schematic Diagram, PSG with Horizontal Internal Return Spring, Externally Adjustable Droop, and Electric Speed Setting

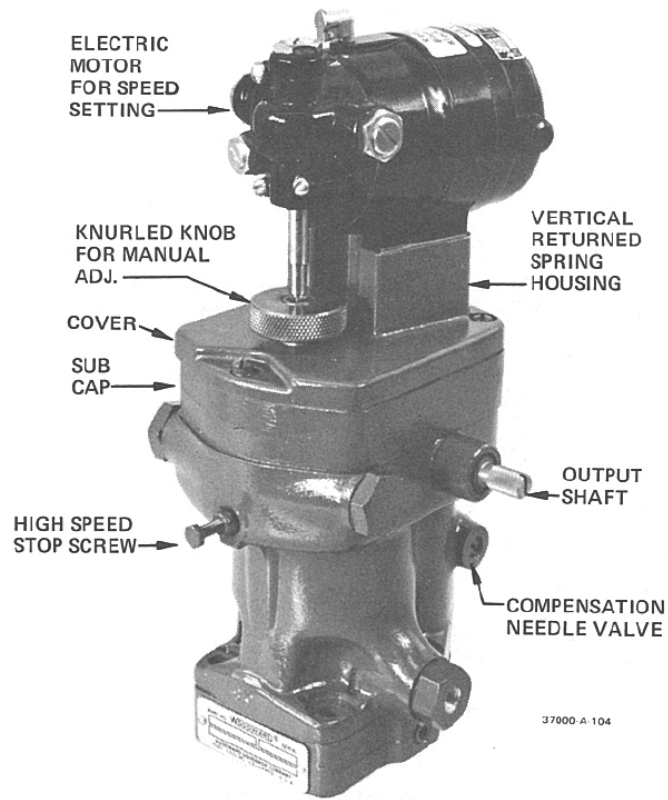

Figure 5-16. PSG with Vertical Return Spring & Bodine Speed Setting Motor

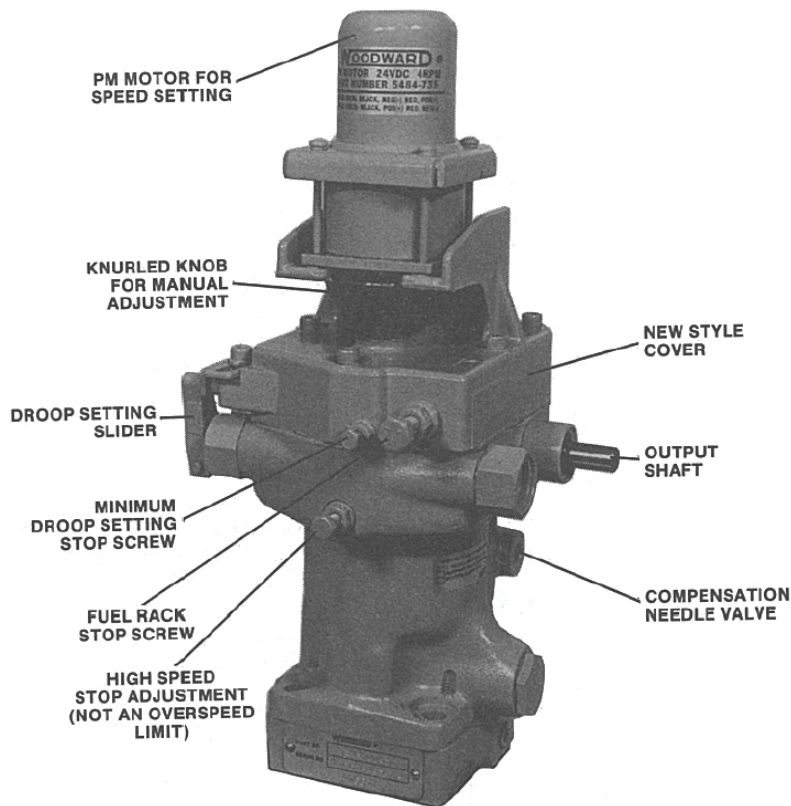

Figure 5-17. PSG with Vertical Return Spring and PM Speed Setting Motor

Externally Adjusted Speed Droop

Refer to Figures 5-18, 5-19, 5-20, 5-21, and 5-22 for externally adjusted droop. Speed droop is adjustable externally between zero and seven percent, depending on speed setting, speeder spring, flyweights, and terminal shaft travel. Speed droop is used to permit load division between two or more engines driving generators in parallel or connected to a single shaft. If the engine is operated alone or on a dc system with proper generator compounding, the governor may be set for zero droop (isochronous operation).

For ac generating units tied in with other units, set the droop sufficiently high to prevent interchange of load between units. If one unit in the system has enough capacity, set its governor to zero droop and it can regulate the frequency of the entire system. This unit can then take all load changes within the limits of its capacity and will control frequency if its capacity is not exceeded.

The speed droop bracket is positioned by means of the speed droop bracket screw (233), lever (294) and two screws (228 and 232) on the outside of the governor case. Two values of droop can be established and a rapid change made between them. Screw (228) is used to establish the zero droop setting and requires no adjustment as it is factory set. Adjust screw (232) with the governor on the engine if the percent of droop has not been specified at the time of manufacture. Bracket screw (233) is used to lock the droop linkage at either of the two positions.

The speed droop lever (238) is mounted on shaft (290) supported by the governor case. The inner end of the shaft is joined to one end of the speed droop linkage (284). The other end of this linkage carries a pivot pin and is supported by the terminal lever. This pin can be adjusted from a position on the terminal shaft centerline to a location with a radius of about one half inch. When the pin is at the shaft center, rotation produces no vertical movement of the pin and therefore no movement of the speed droop lever. As the pin is moved out away from the shaft center, rotation produces movement of the end of the speed droop lever which is pivoted on the speed droop pin. Therefore, when the speed droop lever moves, it produces a speed setting which is a function of terminal shaft position with speed setting decreasing as fuel flow increases. This is speed droop.

Speed droop is increased by moving the external lever forward, and is reduced to zero when the lever is moved back, bringing the pivot pin to the shaft center. Since there is no calibration for the droop adjustment, the zero droop position may be set only by trial and error on the engine, or by use of a dial indicator on the speed droop lever during manual rotation of the terminal shaft. If speed droop is not previously set, it must be set by operation on the engine, readjusting the screw on the side of the governor to obtain the desired speed change between full load and no load.

Disassembly

(See Figures 5-18 & 5-22)

It is not necessary to disassemble the external parts of the speed droop. If it is disassembled, mark the position of the droop bracket (236) before disassembling. Before removing the sub cap (222), refer to the next section about the internal return spring. When the sub cap is removed, remove the speed droop link (284). Pivot the terminal lever (309) upward until slider blocks (285) can be slid out of the slot in the floating lever (294). Notice that the washers (286) straddle each side of floating lever (294). Perform the rest of the disassembly similar to the basic governor, as described previously.

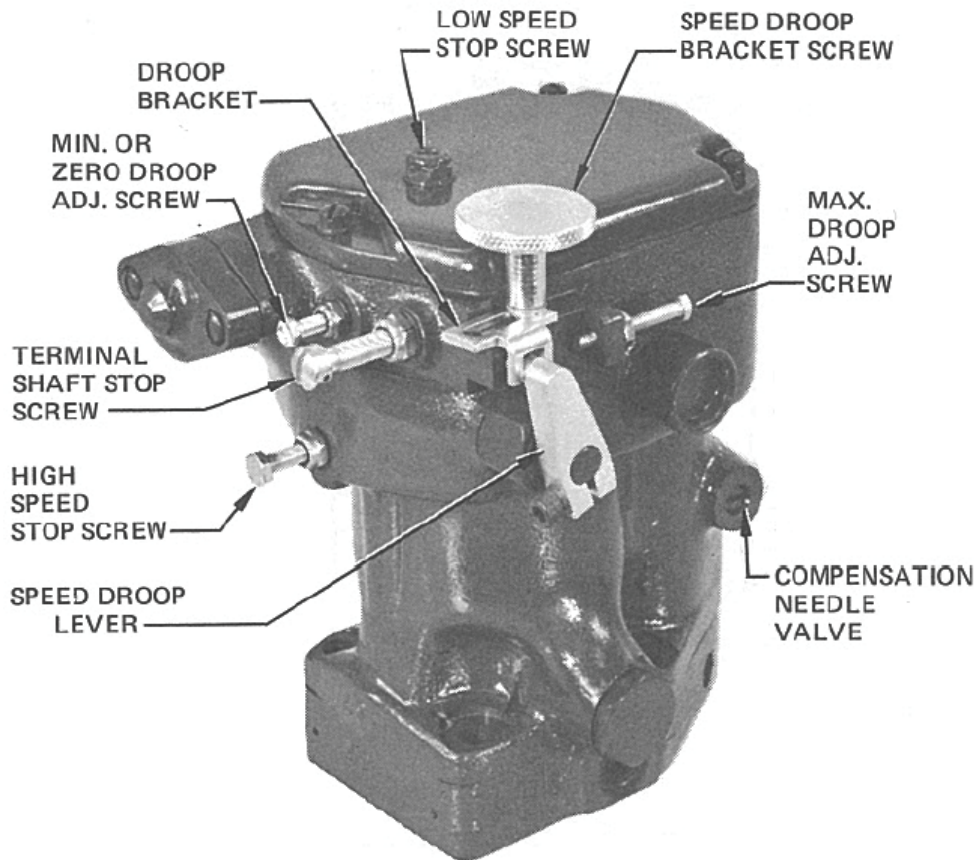

Figure 5-18. PSG with Externally Adjusted Speed Droop

Assembly

Figures 5-19 and 5-20 illustrate the assembly of right and left hand droop linkages respectively.

Assemble speed droop shaft (290) to droop link (284) with screw (289), spacer (288), and nut (283). Be sure droop link (284) pivots freely after nut (283) is tight. Place torsion spring (247) on speed adjusting shaft (246). Insert speed adjusting shaft assembly into case along with droop shaft assembly as shown in Figure 5-19 or 5-20. Fit copper washer (245) on each sleeve and thread them into the case to secure the shafts. Tighten sleeves (243 and 249) with a torque wrench to 30 lb-ft (41 N·m).

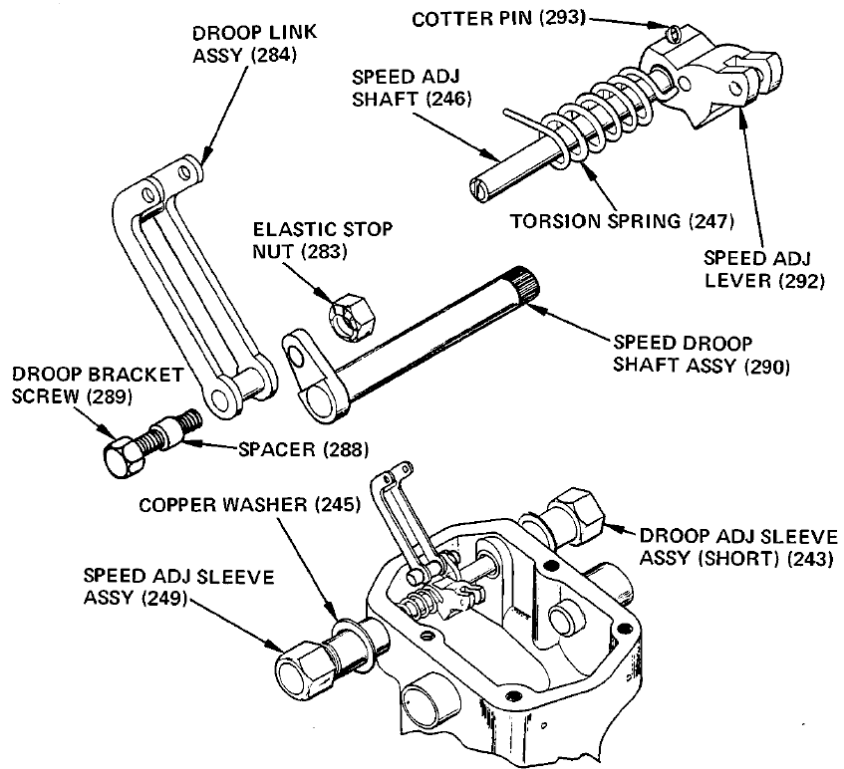

Figure 5-19. Right Hand External Droop Assembly

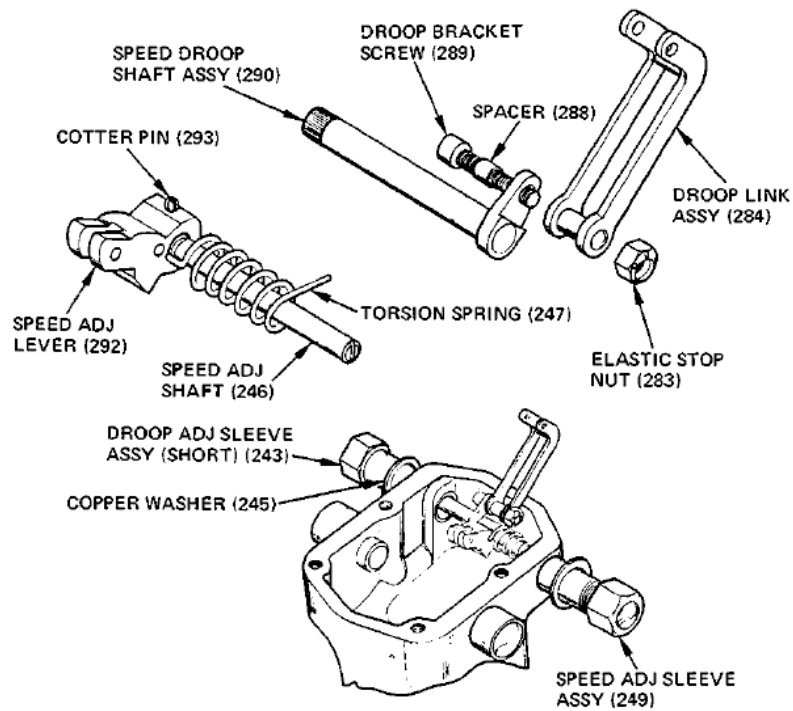

Figure 5-20. Left Hand External Droop Assembly

Internal Return Spring

There are two internal return springs, one is mounted horizontally and one is mounted in a vertical position (inline with the power piston). These mounting positions are referenced with the governor positioned with its drive shaft pointing downward. The internal return springs provide the necessary force required to load the power piston and terminal lever in the decrease fuel direction.

When disassembling the sub cap with a horizontal return spring, pry the wing on the terminal lever, with a small screwdriver, away from the sub cap housing. See Figure 5-21. Place a 1" (25 mm) square by 1/8" (3 mm) thick piece of metal, on top of the guide rod (223) between the spring seat (221, Figure 5-22) and the sub cap housing. This releases the spring force on the terminal lever. Remove the screws (215, Figure 5-22) and lift off the complete sub cap assembly.

WARNING

If for some reason it is necessary to remove cover (218, Figure 5-22), be careful of the spring tension force of spring (220).

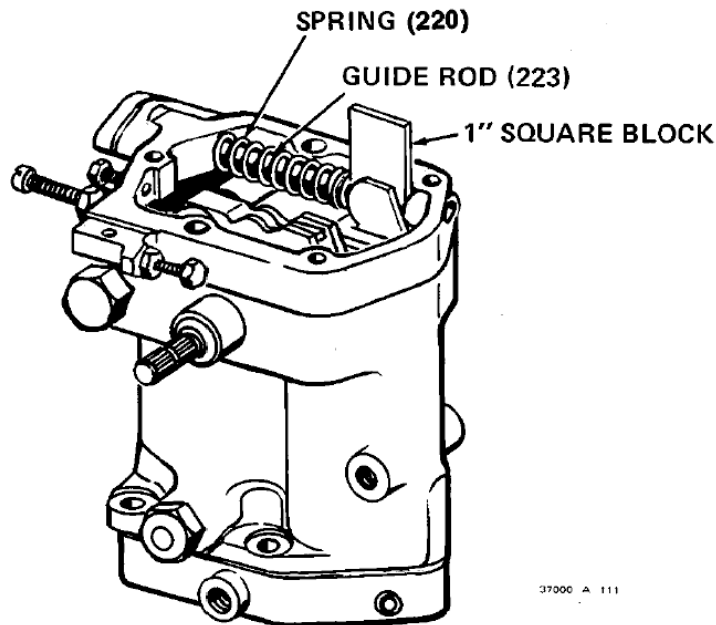

Figure 5-21. Sub Cap Removal

Parts List for Figure 5-22

Ref. No.	Part Name.....	Quantity
37013-201	Motor Assembly.....	1
37013-202	Friction cover.....	1
37013-203	Friction disc	1
37013-204	Fiber washer.....	1
37013-205	Spring washer	1
37013-206	Speed adjusting screw	1
37013-207	Set screw (6-32).....	1
37013-208	Fill. head screw, 10-32 X 1.375".....	3
37013-209	Splitlock washer, #10	6
37013-210	Cover.....	1
37013-211	Gasket.....	2
37013-212	Copper washer	4
37013-213	Fill. head screw, 10-32 X 0.875".....	4
37013-214	Lockwire	1
37013-215	Socket cap screw, 10-32 X 1.000".....	2
37013-216	Lockwasher, 10 high collar.....	2
37013-217	Fill, head screw, 10-32	2
37013-218	Spring pad cover	1
37013-219	Gasket.....	1
37013-220	Horizontal return spring	1
37013-221	Guide rod spring seat	1
37013-222	Subcap	1
37013-223	Spring guide rod.....	1
37013-224	Plug.....	1
37013-225	Load limit screw.....	1
37013-226	Hex nut, 1/4"-28.....	1
37013-227	Copper washer	1
37013-228	Hex head screw, 8-32 X 0.875".....	1
37013-229	Hex nut.....	1
37013-230	Copper washer	1
37013-231	Hex nut, 8-32.....	1
37013-232	Droop adjusting screw.....	1
37013-233	Speed droop bracket screw.....	1
37013-233A	Socket head cap screw	1
37013-234	Shakeproof washer, #10.....	1
37013-235	Washer, 0.380" O.D.	1
37013-236	Bracket	1
37013-237	Socket head screw, 10-32 X 0.625"	1
37013-238	Speed droop lever assembly.....	1
37013-238A	Speed droop adjustment lever, stamping (optional).....	1
37013-239	High speed stop screw, 10-32 X 1.50"	1
37013-240	Elastic stop nut, 10-32.....	1
37013-240A	Jam nut, 10-32	2
37013-241	Copper washer, 0.203 ID.....	1
37013-241A	Thread seal	2
37013-242	Oil seal	4
37013-243	Speed droop adjusting sleeve	1
37013-244	Oilite bushing.....	2
37013-245	Copper washer	3
37013-246	Speed adjusting shaft.....	1
37013-247	Torsion spring.....	1
37013-248	Oilite bushing.....	4
37013-249	Speed adjusting sleeve	1
37013-250	Welch plug.....	2
37013-251	Terminal sleeve (see Note Fig. 5-18)	2
37013-252	Terminal shaft (short)	1
37013-253	Power piston stop screw.....	1
37013-253A	Bushing stop.....	1
37013-254	Terminal shaft (long)	1
37013-255	Relief valve sleeve	1

Ref. No.	Part Name	Quantity
37013-256	Pin.....	1
37013-257	Relief valve spring.....	1
37013-258	Relief valve plunger	1
37013-259	Relief valve stop sleeve	1
37013-260	Needle valve adjusting screw.....	1
37013-261	O-ring	1
37013-262	Washer-spacer.....	0-6 as req'd
37013-263	Bi-metal washer	4-10 as req'd
37013-264	Needle valve	1
37013-265	Loading spring	1
37013-266	Needle valve housing.....	1
37013-267	O-ring	1
37013-268	Plug.....	2
37013-269	Pipe plugs, 1/8".....	3
37013-270	Copper washer.....	1
37013-271	Elastic stop nut, 10-32 thin.....	1
37013-272	Plug.....	1
37013-273	Case assembly (See Note Fig. 5-18)	1
37013-274	Case-base oil seal ring	1
37013-275	Idle gear stud	1
37013-276	Base.....	1
37013-277	Pipe plug, 1/16".....	3
37013-278	Lockwasher.....	3
37013-279	Socket head screw, 1/4"-20 X 1.000".....	3
37013-280	Nameplate.....	1
37013-281	Drive screw	2
37013-282	Dowel pin	2
37013-283	Elastic stop nut, 10-32 thin.....	1
37013-284	Speed droop link assembly.....	1
37013-285	Speed droop slider block	2
37013-286	Washer	2
37013-287	Pin.....	1
37013-288	Spacer	1
37013-289	Socket head screw, 10-32 X 1.000".....	1
37013-290	Speed droop lever assembly.....	1
37013-291	Spring wire pin	1
37013-292	Speed adjusting lever	1
37013-293	Cotter pin	1
37013-294	Floating lever	1
37013-295	Speeder spring assembly.....	1
37013-296	Pilot valve plunger nut.....	1
37013-297	Speeder spring seat.....	1
37013-298	Thrust bearing.....	1
37013-299	Flyweight.....	2
37013-300	Needle bearing.....	4
37013-301	Flyweight pin	2
37013-302	Ballhead.....	1
37013-303	Retaining ring.....	1
37013-304	Retaining ring.....	1
37013-305	Retaining ring.....	1
37013-306	Compensating bushing	1
37013-307	Pilot valve plunger.....	1
37013-308	Cotter pin	2
37013-309	Terminal lever	1
37013-310	Power piston	1
37013-311	Buffer spring.....	2
37013-312	Buffer piston.....	1
37013-313	Buffer spring seat.....	1
37013-314	Retainer ring	1
37013-315	Pilot valve bushing	1
37013-316	Idle gear assembly.....	1
37013-317	Preformed packing.....	2
37013-318	Check valve (optional)	4

IMPORTANT

Terminal sleeve (bushing) 251 can be purchased separately. Installation requires alignment and maybe some reaming. However, when case 273/s purchased, bushing 251 is already installed in the case.

WARNING

Injury may result if compressed spring 220 is suddenly released. Use the proper equipment to remove springs and spring covers.

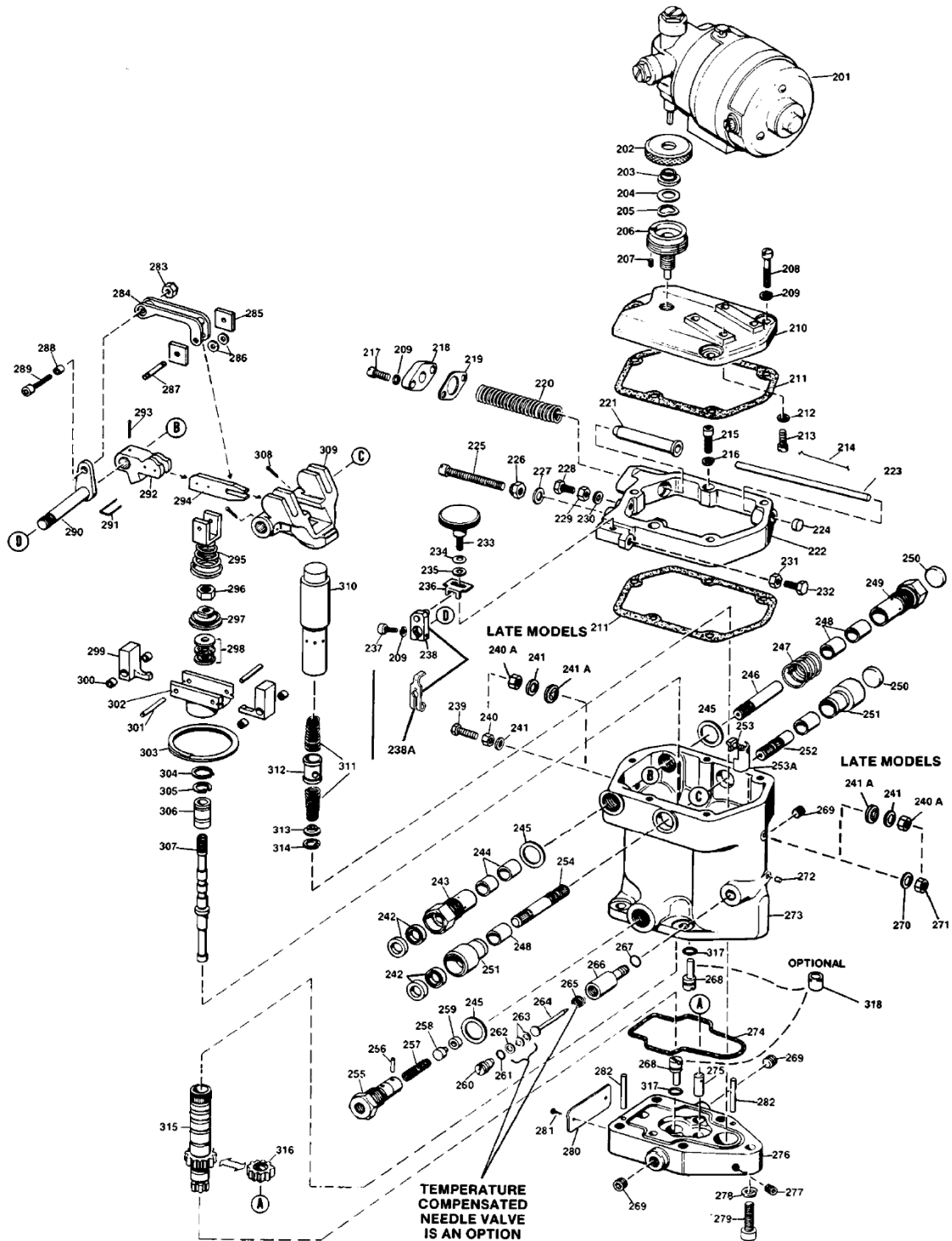

Figure 5-22. Exploded View, PSG with Horizontal Return Spring, Externally Adjusted Droop, Torsion Spring, and Bodine Motor

Parts List for Figure 5-23

! WARNING Be careful when removing the cover on governors equipped with a vertical (in-line with power piston) return spring since the cover compresses the vertical return spring. See the exploded view Figure 5-23. Remove the power piston strut (345) and spring seat (350) with the terminal lever (347). Unless the parts are damaged it should not be necessary to separate the servo strut from the terminal lever.

! WARNING Injury may result if compressed spring 352 is suddenly released. Use the proper equipment to remove springs and spring covers.

! WARNING Do not operate the governor with the cover removed.

Ref. No.	Part Name	Quantity
37013-341	Cover gasket.....	2
37013-342	Sub cap.....	2
37013-343	Washer, 0.296 O.D.	2
37013-344	Soc., hd. cap screw.....	2
37013-345	Power piston strut	1
37013-346	Pivot pin	1
37013-347	Terminal lever	1
37013-348	Soc. hd. cap screw.....	2
37013-349	Lockwasher.....	1
37013-350	Spring seat.....	1
37013-351	Elastic stop nut, 10-32	1
37013-352	Vertical return spring.....	1
37013-353	Cover	1
37013-354	Lockwasher.....	3
37013-355	Screw.....	3
37013-356	Washer, 0.203 X 0.312 X 0.031	1
37013-357	Hex screw, 10-32 X 0.375.....	1
37013-358	Washer, 0.265X 0.500 X 0.031	1
37013-359	Elastic hex nut, 0.250-28	1
37013-360	Screw	1
37013-361	Power piston	1

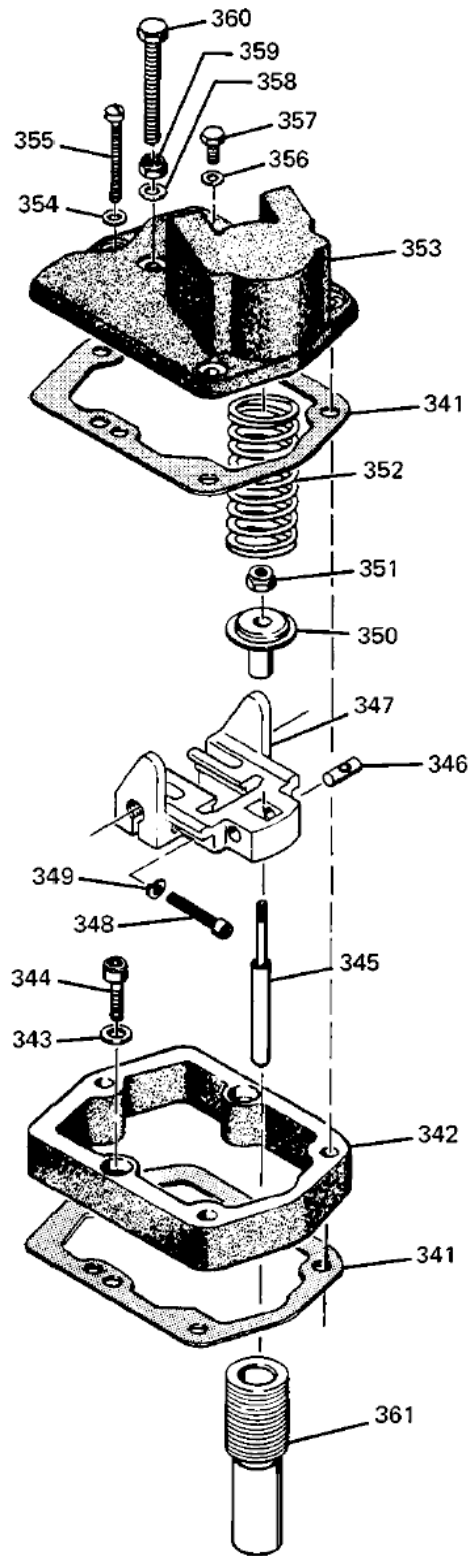

Figure 5-23. Exploded View, PSG Vertical Return Spring

Parts List for Figure 5-24

**WARNING**

Injury may result if compressed spring 439 is suddenly released. Use the proper equipment to remove springs and spring covers.

Ref. No.	Part Name	Quantity
37013-431	Power piston	1
37013-432	Power piston strut	1
37013-433	Terminal lever	1
37013-434	Pivot pin	1
37013-435	Soc. hd. cap screw, 10-32 X 0.750	2
37013-436	Lock washer, #10.....	2
37013-437	Spring seat.....	1
37013-438	Elastic stop nut, 10-32	1
37013-439	Vertical return spring.....	1
37013-440	Cover gasket.....	1
37013-441	Cover	1
37013-442	Speed adjusting screw.....	1
37013-443	Friction washer spring.....	1
37013-444	Washer, 0.750 O.D.	1
37013-445	Friction disc.....	1
37013-446	Friction clutch.....	1
37013-447	Soc. hd. set screw, 6-32 X 0.250	1
37013-448	Electric motor	1
37013-449	Lockwasher, #10.....	4
37013-450	Fillister hd. screw, 10-32 X 0.625.....	4
37013-451	Lockwasher, #10.....	4
37013-452	Screw	4
37013-453	Lockwasher, #10.....	1
37013-454	Hex hd. screw, 10-32	1
37013-455	Hex screw, 10-32 X 0.375.....	1
37013-456	Washer, 0.203 X 0.312 X 0.031	1
37013-457	Washer, 0.203 X 0.312 X 0.031	1
37013-458	Elastic stop nut, 10-32	1
37013-459	Cap screw, 10-32 X 1.500	1

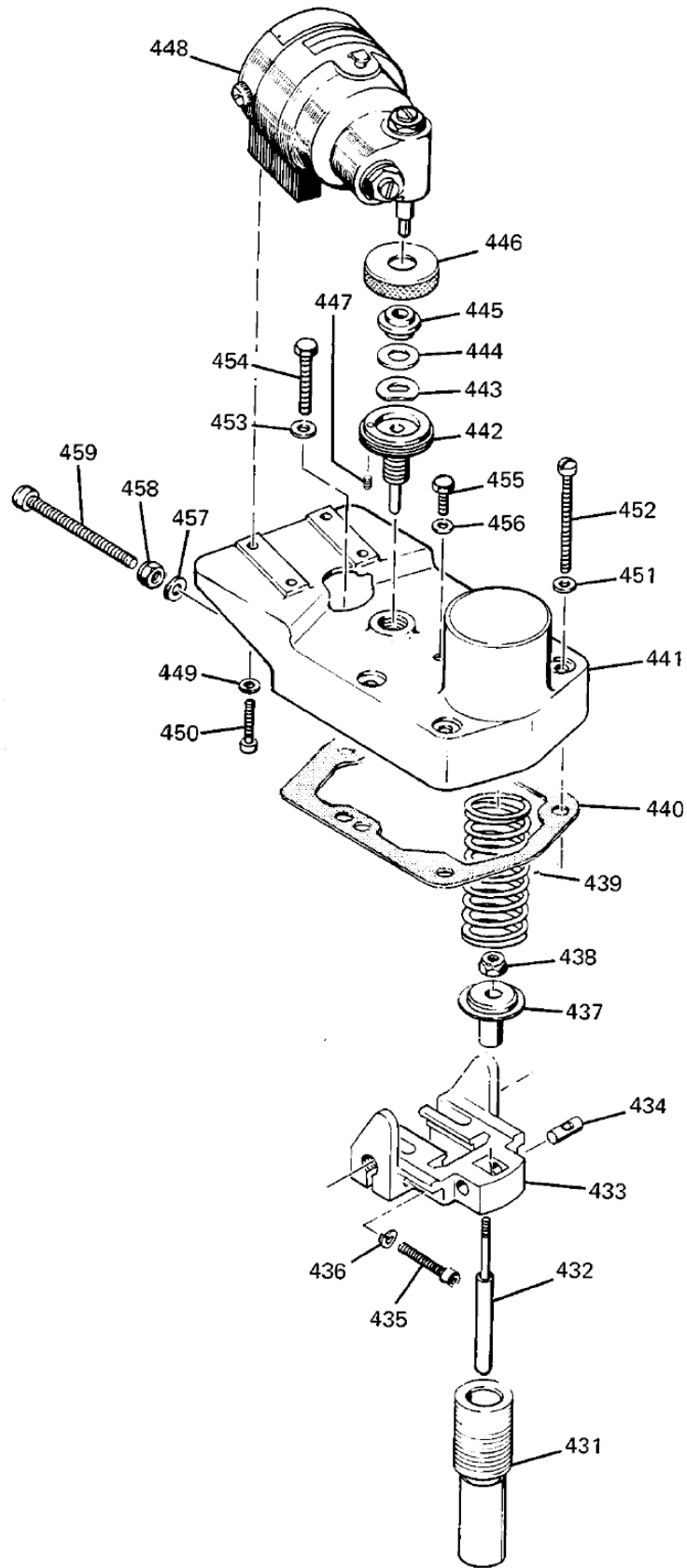

Figure 5-24. Exploded View, PSG Vertical Return Spring Equipped with Electric Motor

Temperature Compensated Needle Valve

This valve (260 through 267, Figure 5-22) is designed to adjust the compensated oil flow as a function of temperature which is related to oil viscosity. This is accomplished with the use of bi-metal strips and a spring loaded needle valve. Adjust the valve the same as a standard valve.

IMPORTANT	Do not close the needle valve to more than a maximum of 6 lb-in (0.7 N·m) of torque as this damages the valve seat.
------------------	--

Fuel Rod

Some PSGs are equipped with a spring loaded fuel rod instead of a terminal shaft. The fuel rod takes the position of the guide rod on the horizontal return spring. Figure 5-25 is an exploded view of one type of fuel rod. Figure 5-26 shows another type.

Parts List for Figure 5-25

! WARNING	Injury may result if compressed springs 377 and 379 are suddenly released. Use the proper equipment to remove springs and spring covers.
------------------	---

Ref. No.	Part Name	Quantity
37013-371	Cover gasket.....	1
37013-372	Sub cap.....	1
37013-373	Washer, 0.296 O.D.	2
37013-374	Soc. hd. cap screw, 10-32 X 1.000	2
37013-375	Fuel rod.....	1
37013-376	Breather pipe adapter	1
37013-377	Compression spring, 0.720 O.D.....	1
37013-378	Shutdown spring seat	1
37013-379	Shutdown compression spring	1
37013-380	Fuel rod spring seat	1
37013-381	Fuel rod housing gasket.....	1
37013-382	Oilite bushing, 0.377 O.D.....	1
37013-383	Oil seal, 0.631 O.D.....	1
37013-384	Fuel rod spacer	1
37013-385	Fuel rod gasket	1
37013-386	Hex nut, 10-32	1
37013-387	Knob	1
37013-388	Lockwasher, #10.....	2
37013-389	Soc. cap screw.....	2
37013-390	Washer, 0.265 X 0.500 X 0.031	1
37013-391	Elastic stop nut, 0.250-28.....	1
37013-392	Stop screw	1

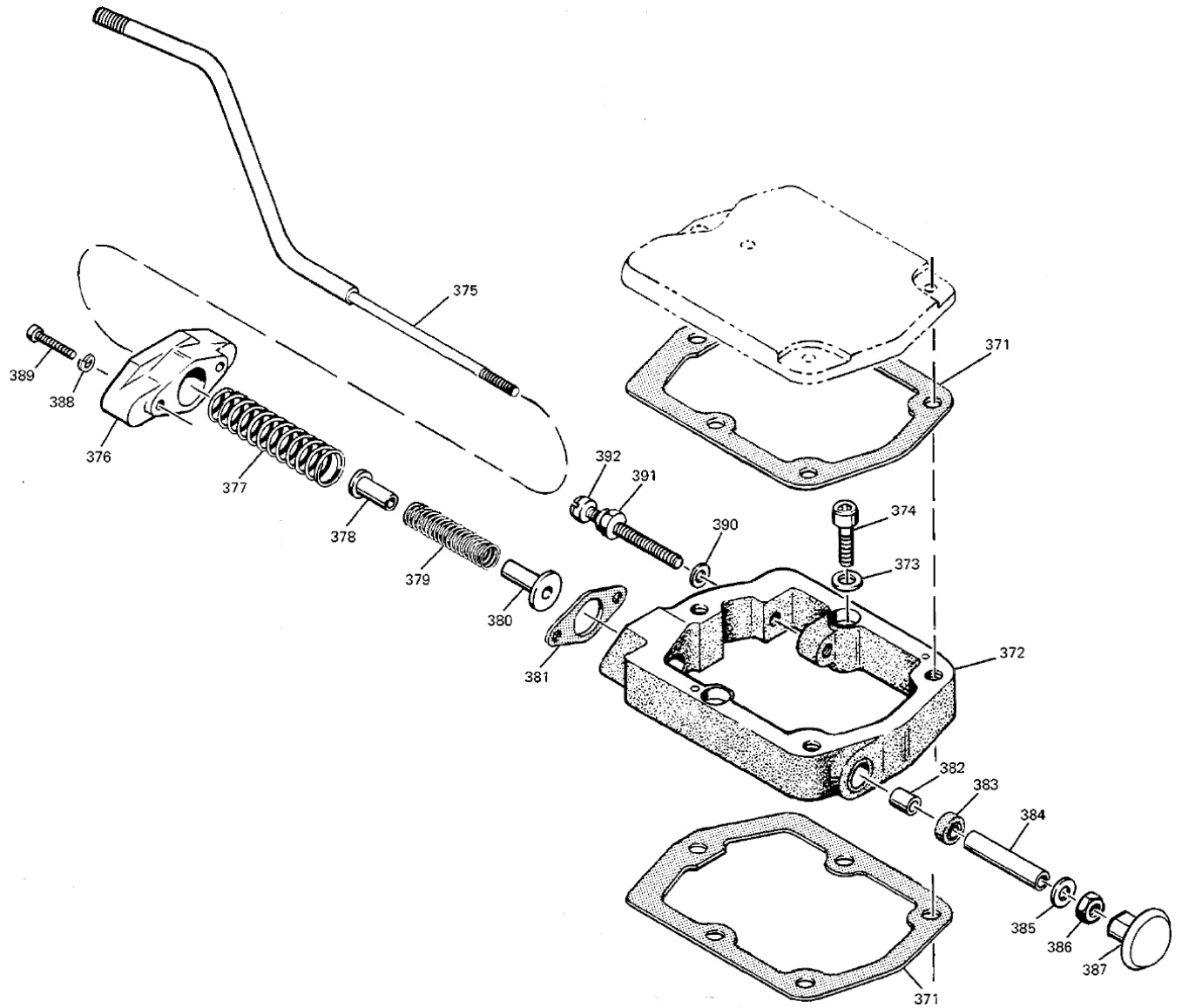

Figure 5-25. Exploded View of PSG Fuel Rod

Parts List for Figure 5-26



WARNING Injury may result if compressed springs 403 and 405 are suddenly released. Use the proper equipment to remove springs and spring covers.

Ref. No.	Part Name	Quantity
37013-401	Fuel rod.....	1
37013-402	Breather pipe adapter	1
37013-403	Compression spring, 0.720 O.D.....	1
37013-404	Shutdown spring seat	1
37013-405	Shutdown compression spring.....	1
37013-406	Fuel rod spring seat	1
37013-407	Fuel rod housing gasket.....	1
37013-408	Oilite bushing, 0.377 O.D.	1
37013-409	Oil seal, 0.631	1
37013-410	Fuel rod spacer.....	1
37013-411	Fuel rod gasket	1
37013-412	Hex nut, 10-32	1
37013-413	Knob	1
37013-414	Sub cap.....	1
37013-415	Lockwasher, #10.....	2
37013-416	Soc. hd. cap screw, 10-32 X 0.625	2

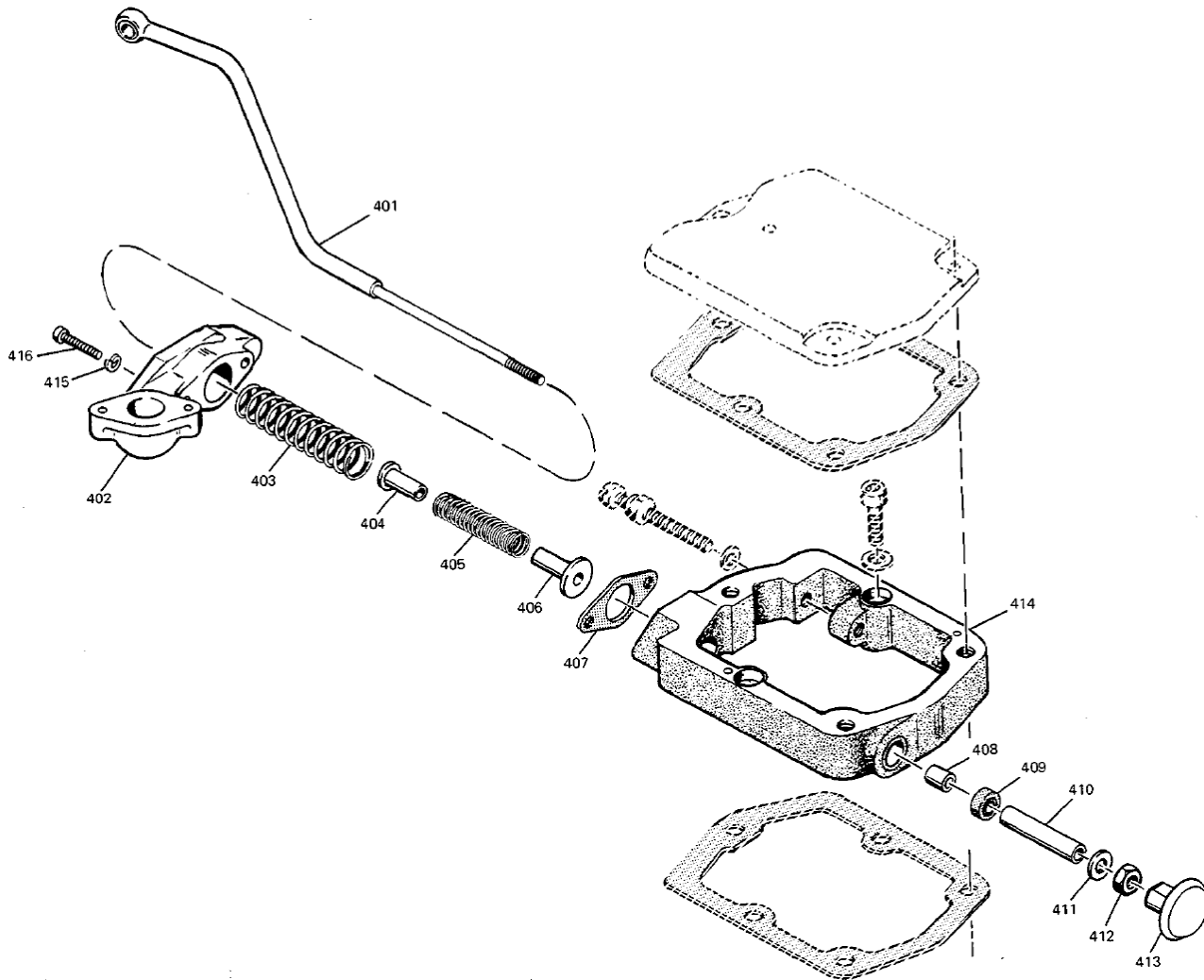

Figure 5-26. Exploded View of PSG Fuel Rod

Parts List for Figure 5-27

WARNING Injury may result if compressed springs 480 is suddenly released. Use the proper equipment to remove springs and spring covers.

Ref. No.	Part Name.....	Quantity
37013-471	Hex. Screw, 0.250-28 x 2.250	1
37013-472	Hex. Nut, 0.250-28, SS.....	2
37013-473	Washer, 0.265 x 0.500 x 0.032 thick, SS2	
37013-474	Seal, 1/4 Nitrile thread	2
37013-475	Plug, low speed guide.....	1
37013-476	Cover	1
37013-477	Soc. hd. cap screw, 10-32 x 1.500.....	5
37013-478	Hex. hd. stop screw, .250-28 x 3.000	1
37013-479	Gasket	1
37013-480	Spring, vertical return.....	1
37013-481	Elastic hex. nut (thin), 10-32	1
37013-482	Spring seat	1
37013-483	Lever assembly.....	1
37013-484	Strut pivot pin.....	1
37013-485	Soc. hd. cap screw 10-32 x 0.875.....	2
37013-486	Servo-piston strut.....	1
37013-487	Servo-piston	1

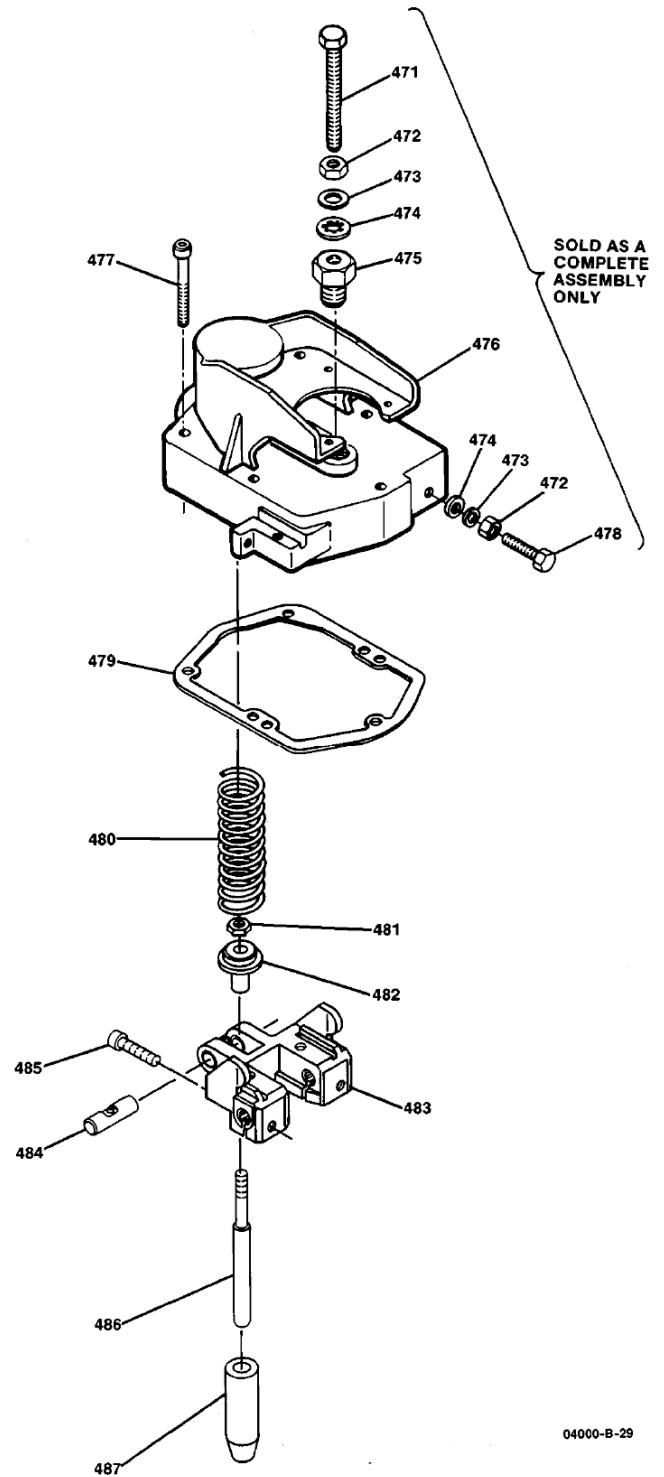

Figure 5-27. Vertical Return Spring Cover and Installation Parts

Adjustments

A friction coupling is incorporated in these cover assemblies to permit overtravel of the motor with no resulting damage. This coupling should be adjusted to slip at 4.5–5.5 lb-in (0.5–0.6 N·m) of torque. The motor must be mounted in such a manner as to center the shaft in the coupling. Full travel of the shaft in each direction should produce no binding.

Parts List for Figure 5-28

Ref. No.	Part Name	Quantity
37013-501	Pan Head Screw, 6-32 x 1.875	4
37013-502	Bracket	1
37013-503	Motor Cover	1
37013-504	Foam Buffer	1
37013-505	PM Motor	1

Items 503, 504, and 505 are epoxied together as an assembly and are furnished that way only.

37013-506	Friction Clutch	1
37013-507	Friction Disc	1
37013-508	Washer, .4381 D.x.750 O.D. x 0.062 Thick	1
37013-509	Friction Spring Washer, 0.375 x 1.0. x 0.750 O.D. x 0.020 Thick	1
37013-510	Speed Adjusting Screw	1
37013-511	Soc. Hd. Cap Screw 10-32 x 1.500	5
37013-512	Cover	1
37013-513	Seal, 1/4 Nitrile Thread	1
37013-514	Washer, 0.265 x 0.500 x 0.032 Thick, SS	1
37013-515	Hex. Nut, 0.250-28, 55	1
37013-516	Hex. Hd. Stop Screw 0.250-28 x 3.000	1

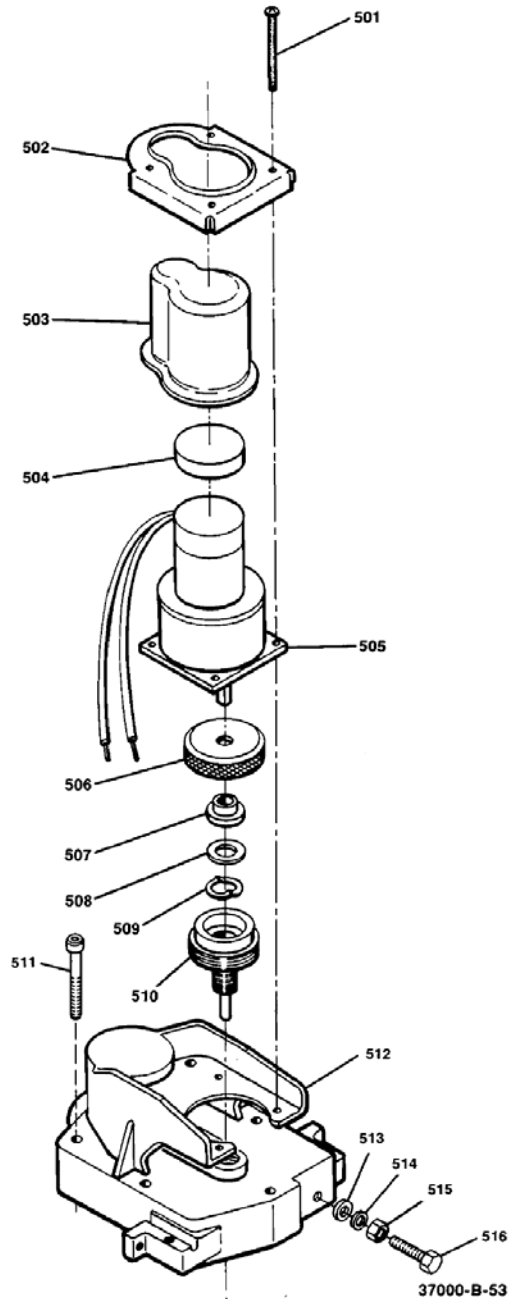
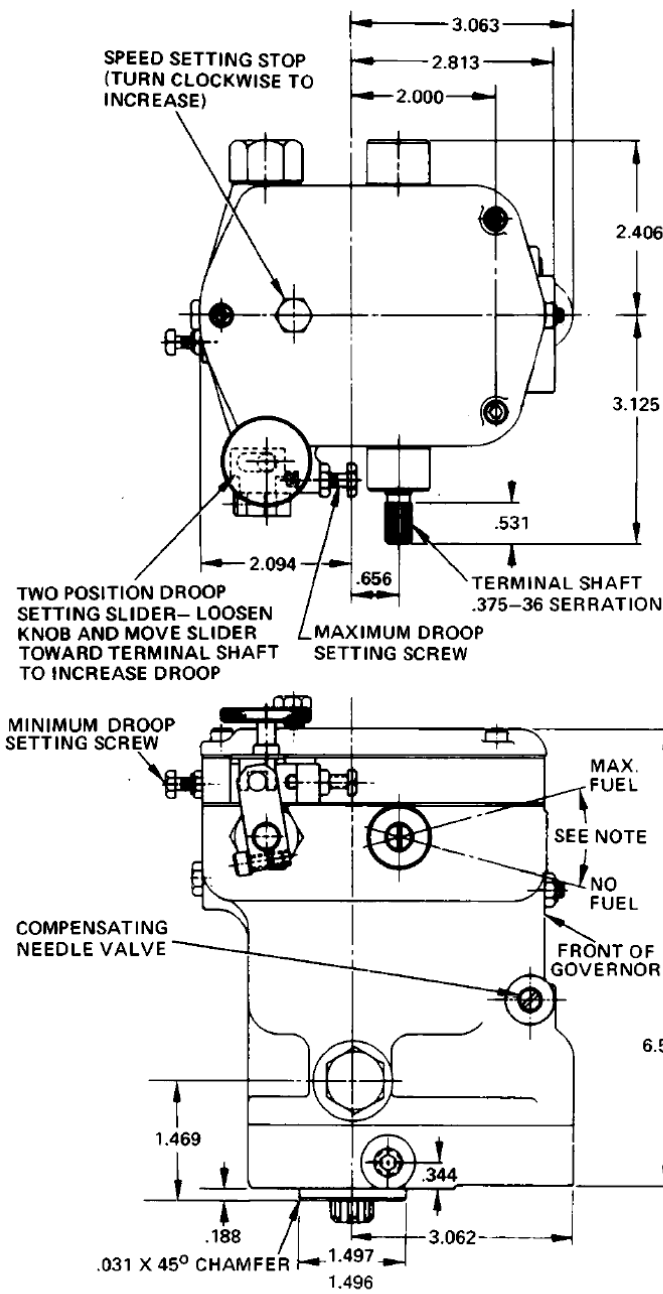

Figure 5-28. Pittman PM Speed Adjusting Motor and Installation Parts



GOVERNOR TO BE MOUNTED HORIZONTALLY WITH SERVO (NAMEPLATE) DOWN

SUPPLY OIL SHOULD BE CLEAN LUBRICATING OIL AT A MINIMUM PRESSURE OF 5 P.S.I. THE OIL MAY BE TAKEN FROM ENGINE IF CAPACITY IS SUFFICIENT. SUCTION LIFTS MUST NOT BE USED WITHOUT PERMISSION FROM WOODWARD GOVERNOR CO. MINIMUM OIL REQUIREMENT IS 2 G.P.M.

GOVERNOR DRIVE SHAFT MAY ROTATE IN EITHER DIRECTION.

*ONLY TWO OF THE THREE BASE DRAINS NEED BE USED COVER DRAIN CONNECTION REQUIRED ONLY WHEN GOVERNOR IS MOUNTED HORIZONTALLY WITH NAMEPLATE DOWN.

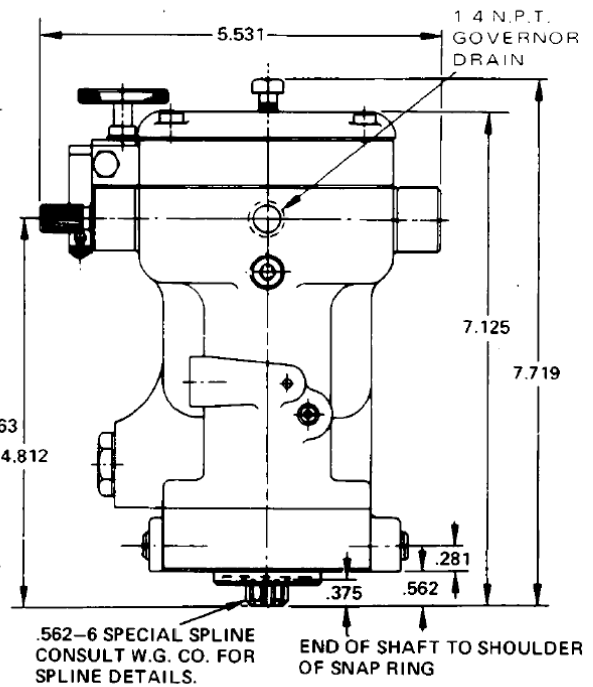

NOTE:

36° MAXIMUM TERMINAL SHAFT ANGULAR ROTATION FROM "NO FUEL" TO FULL FUEL. 2/3 TRAVEL RECOMMENDED FOR NORMAL OPERATION. DO NOT USE LESS THAN 20°

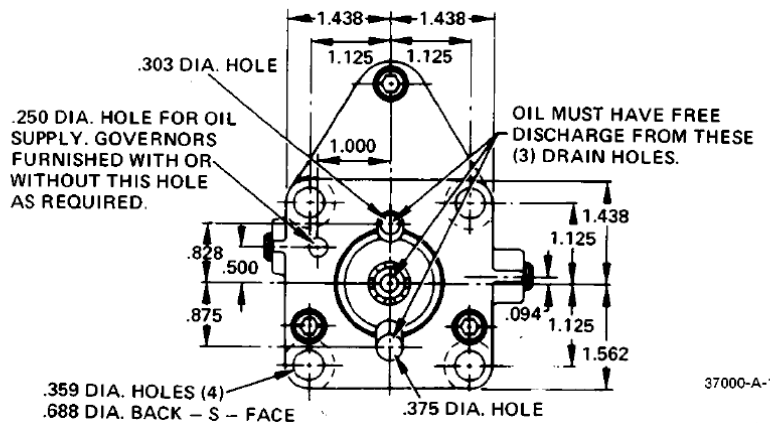

37000-A-103

Figure 5-29. Outline Drawing, PSG with External Droop

Chapter 6.

Product Support and Service Options

Product Support Options

If you are experiencing problems with the installation, or unsatisfactory performance of a Woodward product, the following options are available:

1. Consult the troubleshooting guide in the manual.
2. Contact the **OE Manufacturer or Packager** of your system.
3. Contact the **Woodward Business Partner** serving your area.
4. Contact Woodward technical assistance via email (EngineHelpDesk@Woodward.com) with detailed information on the product, application, and symptoms. Your email will be forwarded to an appropriate expert on the product and application to respond by telephone or return email.
5. If the issue cannot be resolved, you can select a further course of action to pursue based on the available services listed in this chapter.

OEM or Packager Support: Many Woodward controls and control devices are installed into the equipment system and programmed by an Original Equipment Manufacturer (OEM) or Equipment Packager at their factory. In some cases, the programming is password-protected by the OEM or packager, and they are the best source for product service and support. Warranty service for Woodward products shipped with an equipment system should also be handled through the OEM or Packager. Please review your equipment system documentation for details.

Woodward Business Partner Support: Woodward works with and supports a global network of independent business partners whose mission is to serve the users of Woodward controls, as described here:

- A **Full-Service Distributor** has the primary responsibility for sales, service, system integration solutions, technical desk support, and aftermarket marketing of standard Woodward products within a specific geographic area and market segment.
- An **Authorized Independent Service Facility (AISF)** provides authorized service that includes repairs, repair parts, and warranty service on Woodward's behalf. Service (not new unit sales) is an AISF's primary mission.
- A **Recognized Engine Retrofitter (RER)** is an independent company that does retrofits and upgrades on reciprocating gas engines and dual-fuel conversions, and can provide the full line of Woodward systems and components for the retrofits and overhauls, emission compliance upgrades, long term service contracts, emergency repairs, etc.

A current list of Woodward Business Partners is available at www.woodward.com/directory.

Product Service Options

Depending on the type of product, the following options for servicing Woodward products may be available through your local Full-Service Distributor or the OEM or Packager of the equipment system.

- Replacement/Exchange (24-hour service)
- Flat Rate Repair
- Flat Rate Remanufacture

Replacement/Exchange: Replacement/Exchange is a premium program designed for the user who is in need of immediate service. It allows you to request and receive a like-new replacement unit in minimum time (usually within 24 hours of the request), providing a suitable unit is available at the time of the request, thereby minimizing costly downtime.

This option allows you to call your Full-Service Distributor in the event of an unexpected outage, or in advance of a scheduled outage, to request a replacement control unit. If the unit is available at the time of the call, it can usually be shipped out within 24 hours. You replace your field control unit with the like-new replacement and return the field unit to the Full-Service Distributor.

Flat Rate Repair: Flat Rate Repair is available for many of the standard mechanical products and some of the electronic products in the field. This program offers you repair service for your products with the advantage of knowing in advance what the cost will be.

Flat Rate Remanufacture: Flat Rate Remanufacture is very similar to the Flat Rate Repair option, with the exception that the unit will be returned to you in “like-new” condition. This option is applicable to mechanical products only.

Returning Equipment for Repair

If a control (or any part of an electronic control) is to be returned for repair, please contact your Full-Service Distributor in advance to obtain Return Authorization and shipping instructions.

When shipping the item(s), attach a tag with the following information:

- return number;
- name and location where the control is installed;
- name and phone number of contact person;
- complete Woodward part number(s) and serial number(s);
- description of the problem;
- instructions describing the desired type of repair.

Packing a Control

Use the following materials when returning a complete control:

- protective caps on any connectors;
- antistatic protective bags on all electronic modules;
- packing materials that will not damage the surface of the unit;
- at least 100 mm (4 inches) of tightly packed, industry-approved packing material;
- a packing carton with double walls;
- a strong tape around the outside of the carton for increased strength.

NOTICE

To prevent damage to electronic components caused by improper handling, read and observe the precautions in Woodward manual 82715, *Guide for Handling and Protection of Electronic Controls, Printed Circuit Boards, and Modules*.

Replacement Parts

When ordering replacement parts for controls, include the following information:

- the part number(s) (XXXX-XXXX) that is on the enclosure nameplate;
- the unit serial number, which is also on the nameplate.

Engineering Services

Woodward's Full-Service Distributors offer various Engineering Services for our products. For these services, you can contact the Distributor by telephone or by email.

- Technical Support
- Product Training
- Field Service

Technical Support is available from your equipment system supplier, your local Full-Service Distributor, or from many of Woodward's worldwide locations, depending upon the product and application. This service can assist you with technical questions or problem solving during the normal business hours of the Woodward location you contact.

Product Training is available as standard classes at many Distributor locations. Customized classes are also available, which can be tailored to your needs and held at one of our Distributor locations or at your site. This training, conducted by experienced personnel, will assure that you will be able to maintain system reliability and availability.

Field Service engineering on-site support is available, depending on the product and location, from one of our Full-Service Distributors. The field engineers are experienced both on Woodward products as well as on much of the non-Woodward equipment with which our products interface.

For information on these services, please contact one of the Full-Service Distributors listed at www.woodward.com/directory.

Contacting Woodward's Support Organization

For the name of your nearest Woodward Full-Service Distributor or service facility, please consult our worldwide directory published at www.woodward.com/directory.

You can also contact the Woodward Customer Service Department at one of the following Woodward facilities to obtain the address and phone number of the nearest facility at which you can obtain information and service.

Products Used In Electrical Power Systems	Products Used In Engine Systems	Products Used In Industrial Turbomachinery Systems
<u>Facility</u> ----- <u>Phone Number</u>	<u>Facility</u> ----- <u>Phone Number</u>	<u>Facility</u> ----- <u>Phone Number</u>
Brazil -----+55 (19) 3708 4800	Brazil -----+55 (19) 3708 4800	Brazil -----+55 (19) 3708 4800
China -----+86 (512) 6762 6727	China -----+86 (512) 6762 6727	China -----+86 (512) 6762 6727
Germany:	Germany-----+49 (711) 78954-510	India -----+91 (129) 4097100
Kempen----+49 (0) 21 52 14 51	India -----+91 (129) 4097100	Japan-----+81 (43) 213-2191
Stuttgart-- +49 (711) 78954-510	Japan-----+81 (43) 213-2191	Korea-----+82 (51) 636-7080
India -----+91 (129) 4097100	Korea-----+82 (51) 636-7080	The Netherlands- +31 (23) 5661111
Japan-----+81 (43) 213-2191	The Netherlands- +31 (23) 5661111	Poland-----+48 12 295 13 00
Korea-----+82 (51) 636-7080	United States----+1 (970) 482-5811	United States----+1 (970) 482-5811
Poland-----+48 12 295 13 00		
United States----+1 (970) 482-5811		

For the most current product support and contact information, please visit our website directory at www.woodward.com/directory.

Technical Assistance

If you need to contact technical assistance, you will need to provide the following information. Please write it down here before contacting the Engine OEM, the Packager, a Woodward Business Partner, or the Woodward factory:

General

Your Name _____

Site Location _____

Phone Number _____

Fax Number _____

Prime Mover Information

Manufacturer _____

Engine Model Number _____

Number of Cylinders _____

Type of Fuel (gas, gaseous, diesel,
dual-fuel, etc.) _____

Power Output Rating _____

Application (power generation, marine,
etc.) _____

Control/Governor Information

Control/Governor #1

Woodward Part Number & Rev. Letter _____

Control Description or Governor Type _____

Serial Number _____

Control/Governor #2

Woodward Part Number & Rev. Letter _____

Control Description or Governor Type _____

Serial Number _____

Control/Governor #3

Woodward Part Number & Rev. Letter _____

Control Description or Governor Type _____

Serial Number _____

Symptoms

Description _____

If you have an electronic or programmable control, please have the adjustment setting positions or the menu settings written down and with you at the time of the call.

We appreciate your comments about the content of our publications.

Send comments to: icinfo@woodward.com

Please reference publication **37013M**.



B37013:M



PO Box 1519, Fort Collins CO 80522-1519, USA
1000 East Drake Road, Fort Collins CO 80525, USA
Phone +1 (970) 482-5811 • Fax +1 (970) 498-3058

Email and Website—www.woodward.com

Woodward has company-owned plants, subsidiaries, and branches,
as well as authorized distributors and other authorized service and sales facilities throughout the world.

Complete address / phone / fax / email information for all locations is available on our website.