

37385B



DTSC-200 ATS Controller



Installation
Software Version 1.0xxx

Manual 37385B

**WARNING**

Read this entire manual and all other publications pertaining to the work to be performed before installing, operating, or servicing this equipment. Practice all plant and safety instructions and precautions. Failure to follow instructions can cause personal injury and/or property damage.

The engine, turbine, or other type of prime mover should be equipped with an overspeed (overttemperature, or overpressure, where applicable) shutdown device(s), that operates totally independently of the prime mover control device(s) to protect against runaway or damage to the engine, turbine, or other type of prime mover with possible personal injury or loss of life should the mechanical-hydraulic governor(s) or electric control(s), the actuator(s), fuel control(s), the driving mechanism(s), the linkage(s), or the controlled device(s) fail.

Any unauthorized modifications to or use of this equipment outside its specified mechanical, electrical, or other operating limits may cause personal injury and/or property damage, including damage to the equipment. Any such unauthorized modifications: (i) constitute "misuse" and/or "negligence" within the meaning of the product warranty thereby excluding warranty coverage for any resulting damage, and (ii) invalidate product certifications or listings.

**CAUTION**

To prevent damage to a control system that uses an alternator or battery-charging device, make sure the charging device is turned off before disconnecting the battery from the system.

Electronic controls contain static-sensitive parts. Observe the following precautions to prevent damage to these parts.

- Discharge body static before handling the control (with power to the control turned off, contact a grounded surface and maintain contact while handling the control).
- Avoid all plastic, vinyl, and Styrofoam (except antistatic versions) around printed circuit boards.
- Do not touch the components or conductors on a printed circuit board with your hands or with conductive devices.

**OUT-OF-DATE PUBLICATION**

This publication may have been revised or updated since this copy was produced. To verify that you have the latest revision, be sure to check the Woodward website:

<http://www.woodward.com/pubs/current.pdf>

The revision level is shown at the bottom of the front cover after the publication number. The latest version of most publications is available at:

<http://www.woodward.com/publications>

If your publication is not there, please contact your customer service representative to get the latest copy.

Important definitions**WARNING**

Indicates a potentially hazardous situation that, if not avoided, could result in death or serious injury.

**CAUTION**

Indicates a potentially hazardous situation that, if not avoided, could result in damage to equipment.

**NOTE**

Provides other helpful information that does not fall under the warning or caution categories.

Woodward reserves the right to update any portion of this publication at any time. Information provided by Woodward is believed to be correct and reliable. However, Woodward assumes no responsibility unless otherwise expressly undertaken.

© Woodward
All Rights Reserved.

Revision History

Rev.	Date	Editor	Changes
B	2013-07-03	GG	Correction: <ul style="list-style-type: none"> Pin assignment CAN-H/-L corrected on page 32. Manual: <ul style="list-style-type: none"> Phone number on rear page updated
A	08-11-25	TE	Minor corrections
NEW	07-12-12	TP	Release

Content

CHAPTER 1. GENERAL INFORMATION	6
CHAPTER 2. ELECTROSTATIC DISCHARGE AWARENESS	7
CHAPTER 3. HOUSING	8
Panel Cutout.....	8
Dimensions.....	9
Installation	10
Screw Kit Installation	11
CHAPTER 4. WIRING DIAGRAM	12
CHAPTER 5. CONNECTIONS.....	13
Power Supply	14
Earth Ground.....	14
Voltage Measuring (<i>FlexRange</i>).....	15
Voltage Measuring: Source 1.....	15
Voltage Measuring: Source 2.....	20
Current Measuring.....	25
Load	25
Discrete Inputs	27
Discrete Inputs: Bipolar Signals	27
Discrete Inputs: Operation Logic.....	29
Discrete Outputs (Control Outputs And <i>LogicsManager</i>).....	30
Interfaces.....	31
RS-485 Modbus RTU Slave.....	31
CAN Bus (<i>FlexCAN</i>)	32
DPC - Direct Configuration Cable	34
CHAPTER 6. TECHNICAL DATA	35
CHAPTER 7. ENVIRONMENTAL DATA.....	38
CHAPTER 8. ACCURACY	39
APPENDIX A. RECOMMENDED POWER SUPPLY UNITS.....	40

Illustrations and Tables

Illustrations

Figure 3-1: Housing - panel-board cutout.....	8
Figure 3-2: Housing - dimensions.....	9
Figure 3-3: Housing - drill plan	11
Figure 4-1: Wiring diagram	12
Figure 5-1: Power supply.....	14
Figure 5-2: Power supply - crank waveform at maximum load	14
Figure 5-3: Earth ground	14
Figure 5-4: Voltage measuring - source 1	15
Figure 5-5: Voltage measuring -source 1 PT windings, 3ph 4w.....	16
Figure 5-6: Voltage measuring -source 1 measuring inputs, 3ph 4w.....	16
Figure 5-7: Voltage measuring - source 1 PT windings, 3ph 3w.....	17
Figure 5-8: Voltage measuring -source 1 measuring inputs, 3ph 3w.....	17
Figure 5-9: Voltage measuring - source 1 PT windings, 1ph 3w.....	18
Figure 5-10: Voltage measuring -source 1 measuring inputs, 1ph 3w.....	18
Figure 5-11: Voltage measuring - source 1 PT windings, 1ph 2w.....	19
Figure 5-12: Voltage measuring -source 1 measuring inputs, 1ph 2w.....	19
Figure 5-13: Voltage measuring - source 2	20
Figure 5-14: Voltage measuring - source 2 PT windings, 3ph 4w.....	21
Figure 5-15: Voltage measuring -source 2 measuring inputs, 3ph 4w.....	21
Figure 5-16: Voltage measuring - source 2 PT windings, 3ph 3w.....	22
Figure 5-17: Voltage measuring -source 2 measuring inputs, 3ph 3w.....	22
Figure 5-18: Voltage measuring - source 2 PT windings, 1ph 3w.....	23
Figure 5-19: Voltage measuring -source 2 measuring inputs, 1ph 3w.....	23
Figure 5-20: Voltage measuring - source 2 PT windings, 1ph 2w.....	24
Figure 5-21: Voltage measuring -source 2 measuring inputs, 1ph 2w.....	24
Figure 5-22: Current measuring - load.....	25
Figure 5-23: Current measuring - load, L1 L2 L3.....	26
Figure 5-24: Current measuring - load, Phase Lx	26
Figure 5-25: Discrete inputs - alarm/control input - positive signal	27
Figure 5-26: Discrete inputs - alarm/control input - negative signal.....	28
Figure 5-27: Discrete inputs - alarm/control inputs - operation logic.....	29
Figure 5-28: Discrete outputs	30
Figure 5-29: Interface	31
Figure 5-30: RS-485 Modbus - connection for half-duplex operation.....	31
Figure 5-31: RS-485 Modbus - connection for full-duplex operation	31
Figure 5-32: Interfaces - CAN bus (<i>FlexCAN</i>).....	32
Figure 5-33: Interfaces - CAN bus - wiring of shielding	32
Figure 5-34: Interfaces - CAN bus - termination	32

Tables

Table 1-1: Manual - overview	6
Table 3-1: Housing - panel cutout	8
Table 5-1: Conversion chart - wire size	13
Table 5-2: Power supply - terminal assignment	14
Table 5-3: Earth ground - terminal assignment	14
Table 5-4: Voltage measuring - terminal assignment - source 1	15
Table 5-5: Voltage measuring - terminal assignment - source 1, 3ph 4w	16
Table 5-6: Voltage measuring - terminal assignment - source 1, 3ph 3w	17
Table 5-7: Voltage measuring - terminal assignment - source 1, 1ph 3w	18
Table 5-8: Voltage measuring - terminal assignment - source 1, 1ph 2w	19
Table 5-9: Voltage measuring - terminal assignment - source 2 voltage	20
Table 5-10: Voltage measuring - terminal assignment - source 2, 3ph 4w	21
Table 5-11: Voltage measuring - terminal assignment - source 2, 3ph 3w	22
Table 5-12: Voltage measuring - terminal assignment - source 2, 1ph 3w	23
Table 5-13: Voltage measuring - terminal assignment - source 2, 1ph 2w	24
Table 5-14: Current measuring - terminal assignment - load current	25
Table 5-15: Current measuring - terminal assignment - load, L1 L2 L3	26
Table 5-16: Current measuring - terminal assignment - load, Phase Lx	26
Table 5-17: Discrete input - terminal assignment - alarm/control inputs	28
Table 5-18: Discrete outputs - terminal assignment	30
Table 5-19: RS-485 Modbus interface - terminal assignment	31
Table 5-20: CAN bus interface - terminal assignment	32
Table 5-21: Maximum CAN bus length	33

Chapter 1. General Information

Type	English	German
DTSC-200 Series		
DTSC-200 - Installation	this manual ⇨	37385
DTSC-200 - Configuration	37386	-
DTSC-200 - Operation	37387	-
DTSC-200 - Application	37388	-
DTSC-200 - Interfaces	37389	-
Additional Manuals		
LeoPC1 - User Manual	37146	GR37146
PC program for visualization, configuration, remote control, data logging, language upload, alarm and user management, and management of the event recorder. This manual describes the set up of the program and interfacing with the control unit.		
LeoPC1 - Engineering Manual	37164	GR37164
PC program for visualization, configuration, remote control, data logging, language upload, alarm and user management, and management of the event recorder. This manual describes the configuration and customization of the program.		

Table 1-1: Manual - overview

Intended Use The unit must only be operated in the manner described by this manual. The prerequisite for a proper and safe operation of the product is correct transportation, storage, and installation as well as careful operation and maintenance.



NOTE

This manual has been developed for a unit fitted with all available options. Inputs/outputs, functions, configuration screens, and other details described, which do not exist on your unit, may be ignored. The present manual has been prepared to enable the installation and commissioning of the unit. Due to the large variety of parameter settings, it is not possible to cover every combination. The manual is therefore only a guide. In case of incorrect entries or a total loss of functions, the default settings may be taken from the list of parameters enclosed in the configuration manual 37386.

Chapter 2.

Electrostatic Discharge Awareness

All electronic equipment is static-sensitive, some components more than others. To protect these components from static damage, you must take special precautions to minimize or eliminate electrostatic discharges.

Follow these precautions when working with or near the control.

1. Before doing maintenance on the electronic control, discharge the static electricity on your body to ground by touching and holding a grounded metal object (pipes, cabinets, equipment, etc.).
2. Avoid the build-up of static electricity on your body by not wearing clothing made of synthetic materials. Wear cotton or cotton-blend materials as much as possible because these do not store static electric charges as easily as synthetics.
3. Keep plastic, vinyl, and Styrofoam materials (such as plastic or Styrofoam cups, cigarette packages, cellophane wrappers, vinyl books or folders, plastic bottles, etc.) away from the control, modules, and work area as much as possible.
4. **Opening the control cover may void the unit warranty.**
Do not remove the printed circuit board (PCB) from the control cabinet unless absolutely necessary. If you must remove the PCB from the control cabinet, follow these precautions:
 - Ensure that the device is completely voltage-free (all connectors have to be disconnected).
 - Do not touch any part of the PCB except the edges.
 - Do not touch the electrical conductors, connectors, or components with conductive devices or with bare hands.
 - When replacing a PCB, keep the new PCB in the plastic antistatic protective bag it comes in until you are ready to install it. Immediately after removing the old PCB from the control cabinet, place it in the antistatic protective bag.



CAUTION

To prevent damage to electronic components caused by improper handling, read and observe the precautions in Woodward manual 82715, *Guide for Handling and Protection of Electronic Controls, Printed Circuit Boards, and Modules*.

Chapter 3. Housing

Panel Cutout

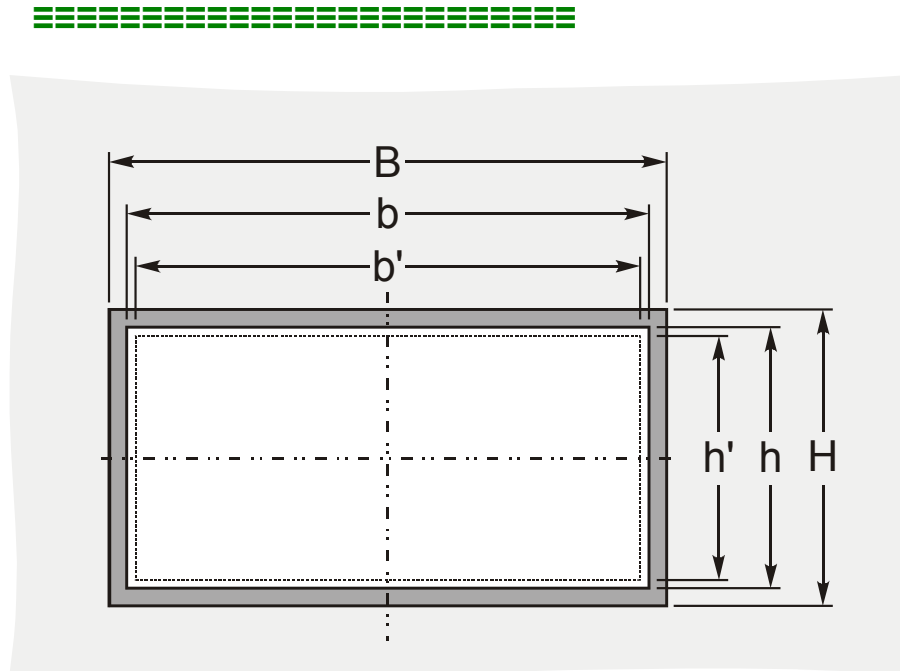

Figure 3-1: Housing - panel-board cutout

Measure	Description		Tolerance
H	Height	Total	171 mm (6.73 in) ---
		Panel cutout	138 mm (5.43 in) + 1.0 mm (0.04 in)
		Housing dimension	136 mm (5.35 in)
B	Width	Total	219 mm (8.62 in) ---
		Panel cutout	186 mm (7.32 in) + 1.1 mm (0.04 in)
		Housing dimension	185 mm (7.28 in)
	Depth	Total	61 mm (2.40 in) ---

Table 3-1: Housing - panel cutout

The maximum permissible corner radius is 3.5 mm (0.14 in).
Refer to Figure 3-3 on page 11 for a cutout drawing.

Dimensions

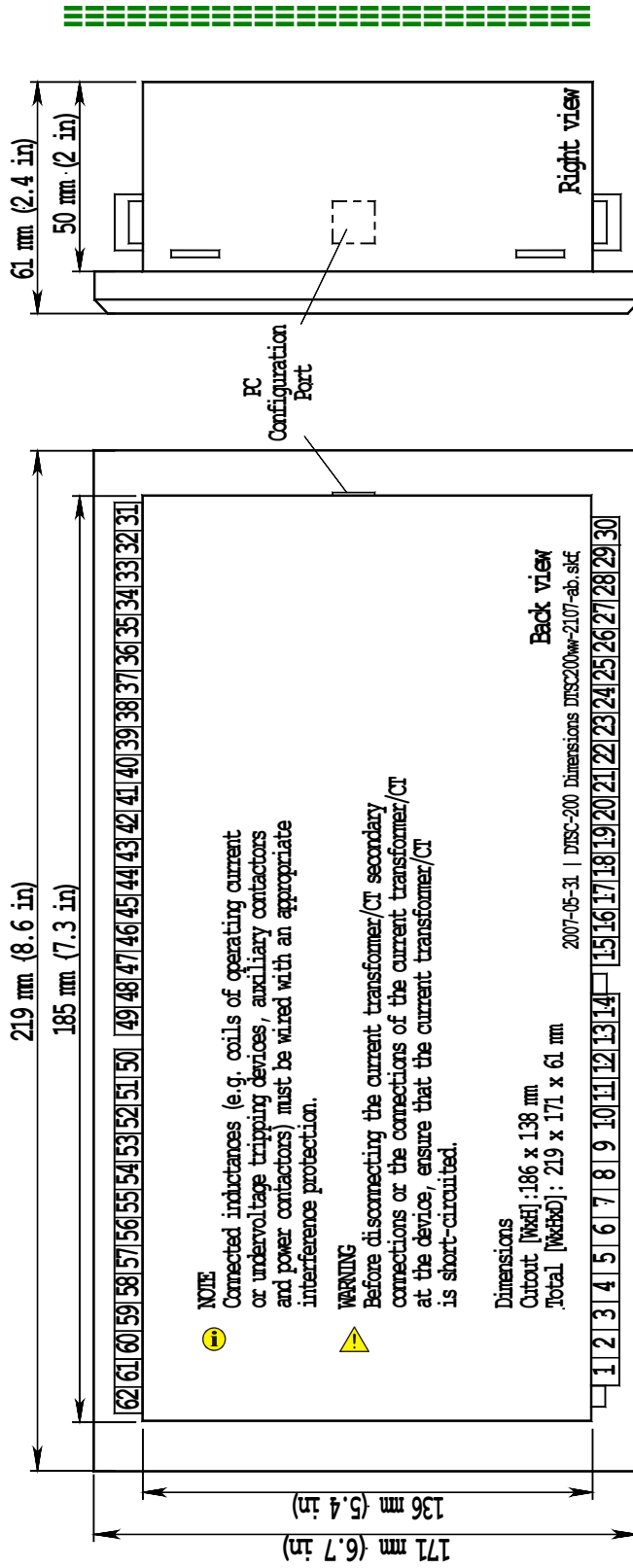

Figure 3-2: Housing - dimensions

Installation



For installation into a panel door with the fastening clamps, please proceed as follows:

1. **Panel cutout**

Cut out the panel according to the dimensions in Figure 3-3.

Note: It is not necessary to drill the holes if the fastening clamps are used.

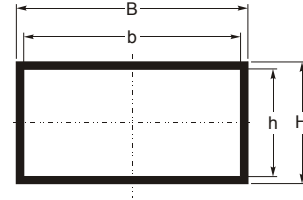

2. **Remove terminals**

Loosen the wire connection terminal screws on the back of the unit and remove the wire connection terminal strip if required.

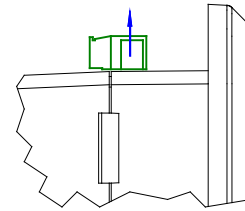

3. **Insert screws in clamps**

Insert the four clamping screws into the clamp inserts from the shown side (opposite of the nut insert) until they are almost flush. Do not completely insert the screws into the clamp inserts.

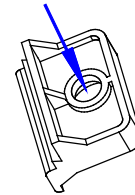

4. **Insert unit into cutout**

Insert the unit into the panel cutout. Verify that the unit fits correctly in the cutout. If the panel cutout is not big enough, enlarge it accordingly.

5. **Attach clamp inserts**

Re-install the clamp inserts by tilting the insert to a 45° angle. (1) Insert the nose of the insert into the slot on the side of the housing. (2) Raise the clamp insert so that it is parallel to the control panel.

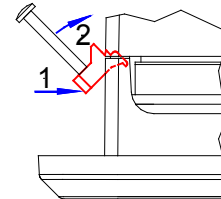

6. **Tighten clamping screws**

Tighten the clamping screws (1) until the control unit is secured to the control panel (2). Over tightening of these screws may result in the clamp inserts or the housing breaking. Do not exceed the recommended tightening torque of 0.1 Nm (0.9 pound-force inches).

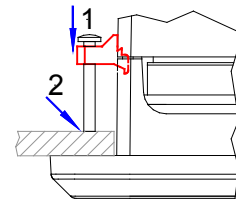

7. **Reattach terminals**

Reattach the wire connection terminal strip (1) and secure them with the side screws.

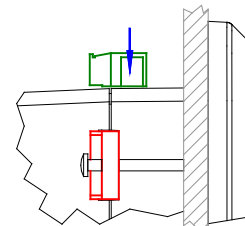

Screw Kit Installation



In order to enhance the protection from front to IP 65, it is possible to fasten the unit with a screw kit instead of the clamp fastener hardware.

Proceed as follows to install the unit using the screw kit:

1. Cut out the panel and drill the holes according to the dimensions in Figure 3-3.
2. Insert the unit into the panel cutout. Verify that the unit fits correctly in the cutout. If the panel cutout is not big enough, enlarge it accordingly.
3. Insert the screws and tighten to 0.6 Nm (5.3 pound-force inches) of torque. Tighten the screws with a cross-wise pattern to ensure even pressure distribution.



NOTE

If the thickness of the panel sheet exceeds 2.5 mm (0.1 in), be sure to use screws with a length of the panel sheet thickness + 4 mm (0.16 in).

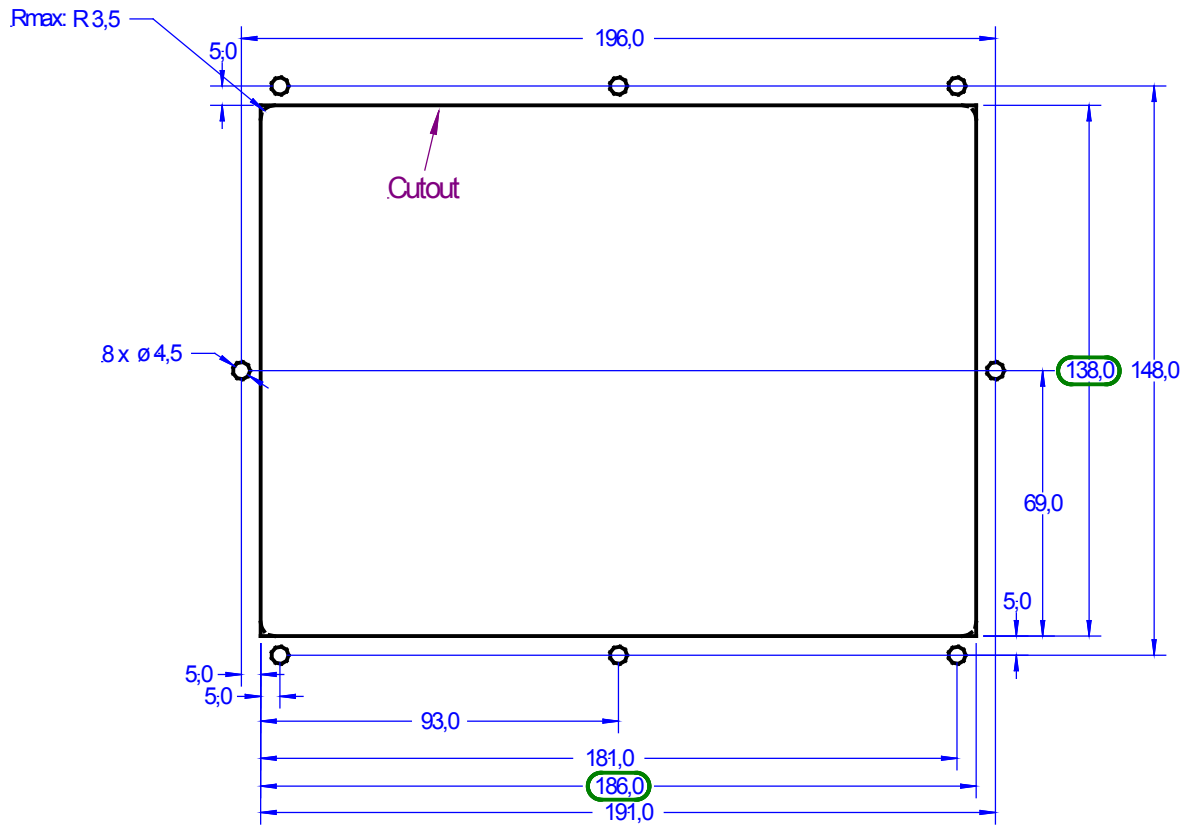

Cutout dimension: 186,0
 186 mm (+1.1 mm) x 138 mm (+1.0 mm) according to DIN 43700/IEC 61554
 7.32 in (+0.045 in) x 5.43 in (+0.04 in)

2006-09-05 | DTSC-200 cutout+drillplan DTSC200ww-3606-ab.SKF

Unit will be mounted with 8 screws (P/N: LR02236) M4 x 6 mm, torque 0.6Nm.

Figure 3-3: Housing - drill plan

Chapter 5. Connections



WARNING

All technical data and ratings indicated in this chapter are not definite! Only the values indicated in Chapter 6: Technical Data on page 35 are valid!

The following chart may be used to convert square millimeters [mm²] to AWG and vice versa:

AWG	mm ²	AWG	mm ²	AWG	mm ²	AWG	mm ²	AWG	mm ²	AWG	mm ²
30	0.05	21	0.38	14	2.5	4	25	3/0	95	600MCM	300
28	0.08	20	0.5	12	4	2	35	4/0	120	750MCM	400
26	0.14	18	0.75	10	6	1	50	300MCM	150	1000MCM	500
24	0.25	17	1.0	8	10	1/0	55	350MCM	185		
22	0.34	16	1.5	6	16	2/0	70	500MCM	240		

Table 5-1: Conversion chart - wire size

Power Supply

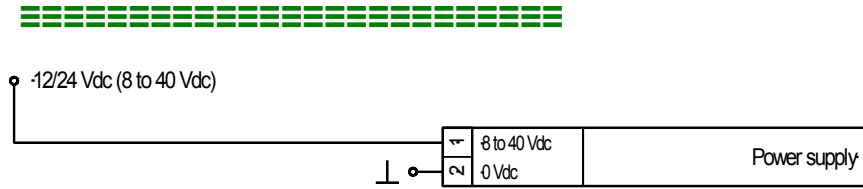

Figure 5-1: Power supply

Terminal	Description	A _{max}
1	12/24Vdc (8 to 40 Vdc), 15 W	2.5 mm ²
2	0 Vdc reference potential	2.5 mm ²

Table 5-2: Power supply - terminal assignment

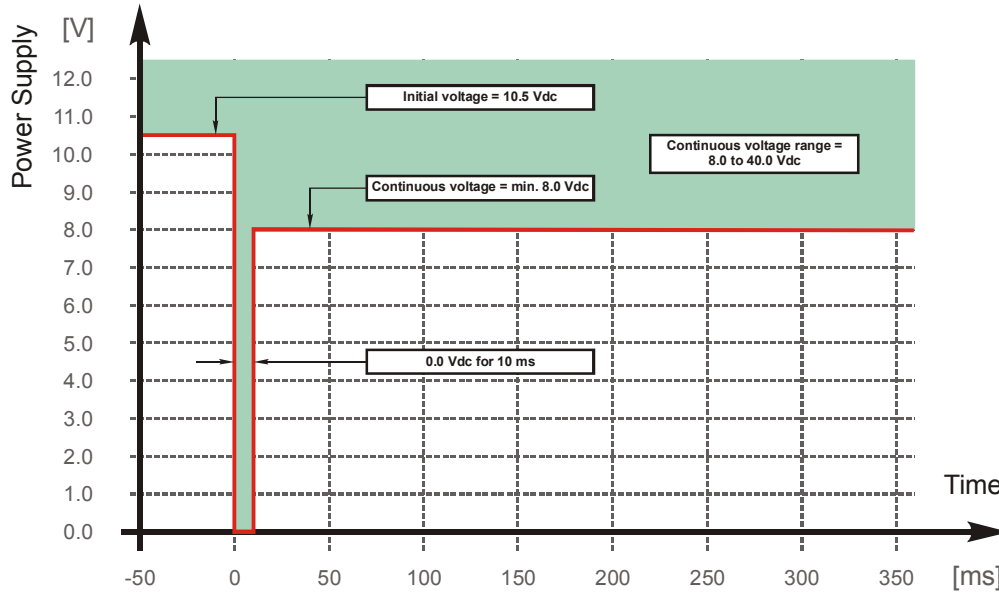

Figure 5-2: Power supply - crank waveform at maximum load



NOTE

Woodward recommends to fuse-protect all lines according to their rated load (rated current). Refer to Appendix A: Recommended Power Supply Units on page 40 for suitable power supply units.

Earth Ground

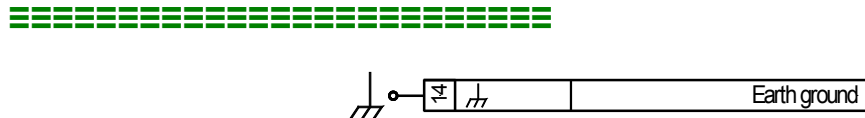

Figure 5-3: Earth ground

Terminal	Description	A _{max}
14	Earth ground connection	2.5 mm ²

Table 5-3: Earth ground - terminal assignment



NOTE

Woodward recommends to connect this terminal to ground to comply with the EMC directives.

Voltage Measuring (*FlexRange*)



NOTE

DO NOT use both sets of voltage measuring inputs. The control unit will not measure voltage correctly if the 100 V and 400 V inputs are utilized simultaneously.



NOTE

Woodward recommends protecting the voltage measuring inputs with slow-acting fuses rated for 2 to 6 A.

Voltage Measuring: Source 1

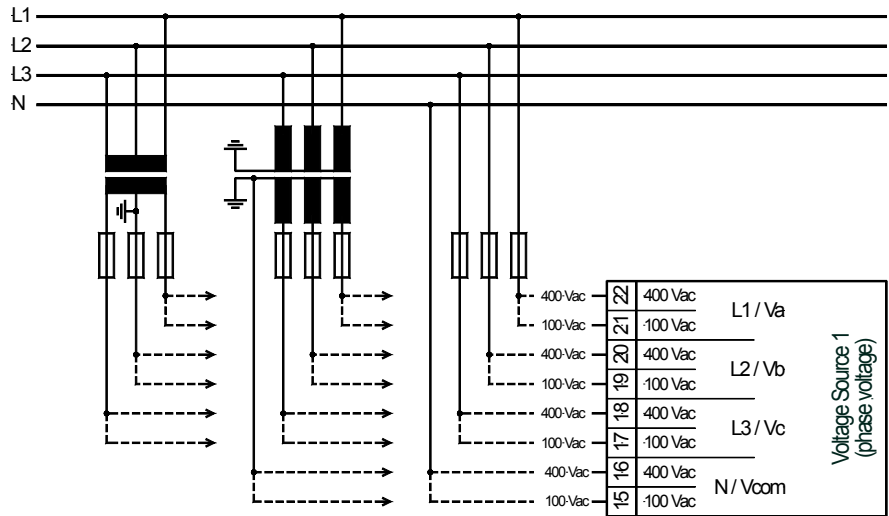

Figure 5-4: Voltage measuring - source 1

Terminal	Description		A _{max}
15	Source 1 voltage - phase N	100 Vac	2.5 mm ²
16		400 Vac	2.5 mm ²
17	Source 1 voltage - phase L3	100 Vac	2.5 mm ²
18		400 Vac	2.5 mm ²
19	Source 1 voltage - phase L2	100 Vac	2.5 mm ²
20		400 Vac	2.5 mm ²
21	Source 1 voltage - phase L1	100 Vac	2.5 mm ²
22		400 Vac	2.5 mm ²

Table 5-4: Voltage measuring - terminal assignment - source 1



NOTE

The 100 V input terminals must be used, if parameter "S1 voltage transf. secondary" (refer to Configuration Manual 37386) is configured with a value between 50 and 130 V for proper measurement.

The 400 V input terminals must be used, if parameter "S1 voltage transf. secondary" (refer to Configuration Manual 37386) is configured with a value between 131 and 480 V for proper measurement.

Voltage Measuring: Source 1, parameter setting '3ph 4w' (3phase, 4wire)

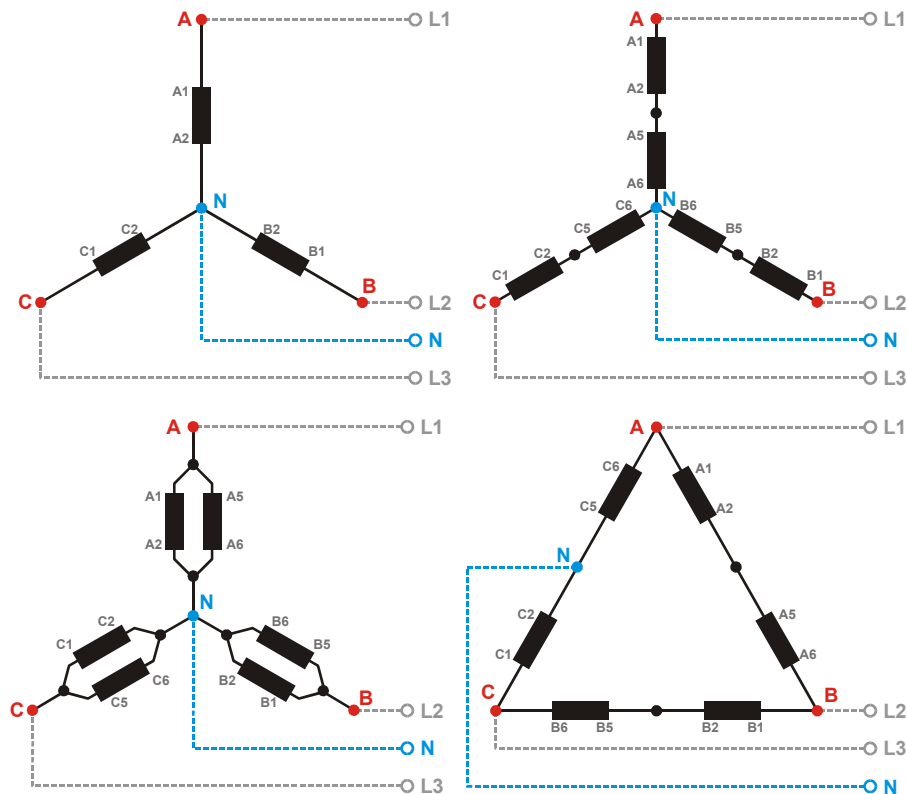

Figure 5-5: Voltage measuring -source 1 PT windings, 3ph 4w

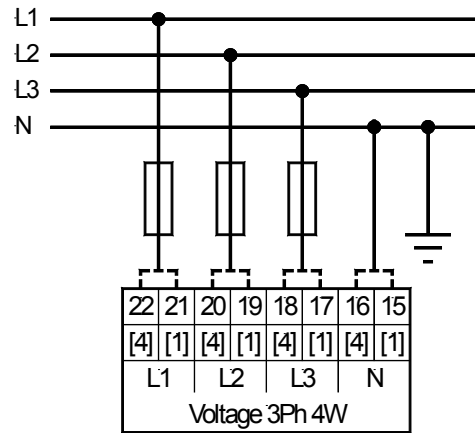

Figure 5-6: Voltage measuring -source 1 measuring inputs, 3ph 4w

3ph 4w	Wiring terminals								Note
	Rated voltage (range)	[1] 100 V (50 to 130 V _{eff})				[4] 400 V (131 to 480 V _{eff})			
Measuring range (max.)	[1] 0 to 150 Vac				[4] 0 to 600 Vac				
DTSC-200 terminal	21	19	17	15	22	20	18	16	
Phase	L1	L2	L3	N	L1	L2	L3	N	

Table 5-5: Voltage measuring - terminal assignment - source 1, 3ph 4w

1 For different voltage systems, different wiring terminals have to be used. Incorrect measurements are possible if both voltage systems use the same N terminal.

Voltage Measuring: Source 1, parameter setting '3ph 3w' (3phase, 3wire)

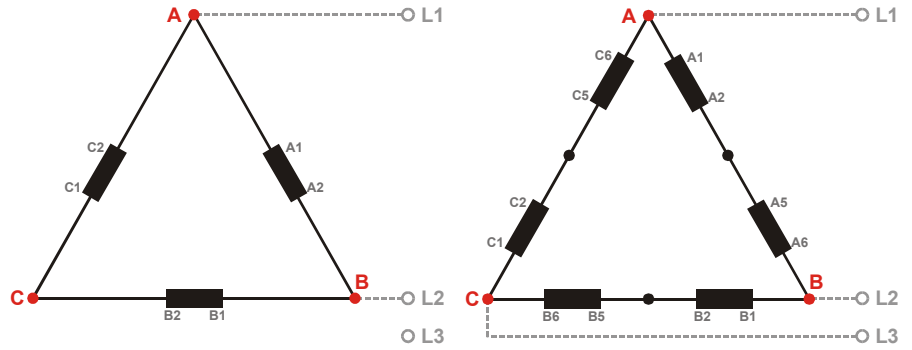

Figure 5-7: Voltage measuring - source 1 PT windings, 3ph 3w

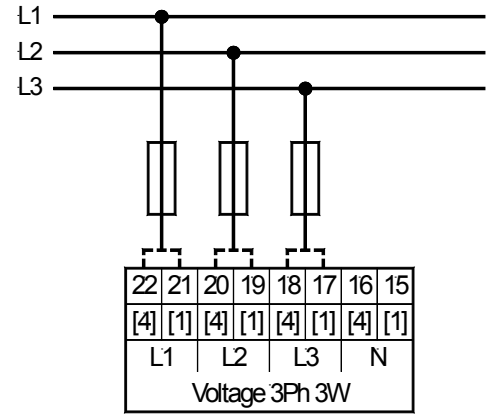

Figure 5-8: Voltage measuring -source 1 measuring inputs, 3ph 3w

3ph 3w	Wiring terminals								Note
	Rated voltage (range)	[1] 100 V (50 to 130 V _{eff})				[4] 400 V (131 to 480 V _{eff})			
Measuring range (max.)	[1] 0 to 150 Vac				[4] 0 to 600 Vac				
DTSC-200 terminal	21	19	17	15	22	20	18	16	
Phase	L1	L2	L3	---	L1	L2	L3	---	

Table 5-6: Voltage measuring - terminal assignment - source 1, 3ph 3w

2 For different voltage systems, different wiring terminals have to be used.

Voltage Measuring: Source 1, parameter setting '1ph 3w' (1phase, 3wire)

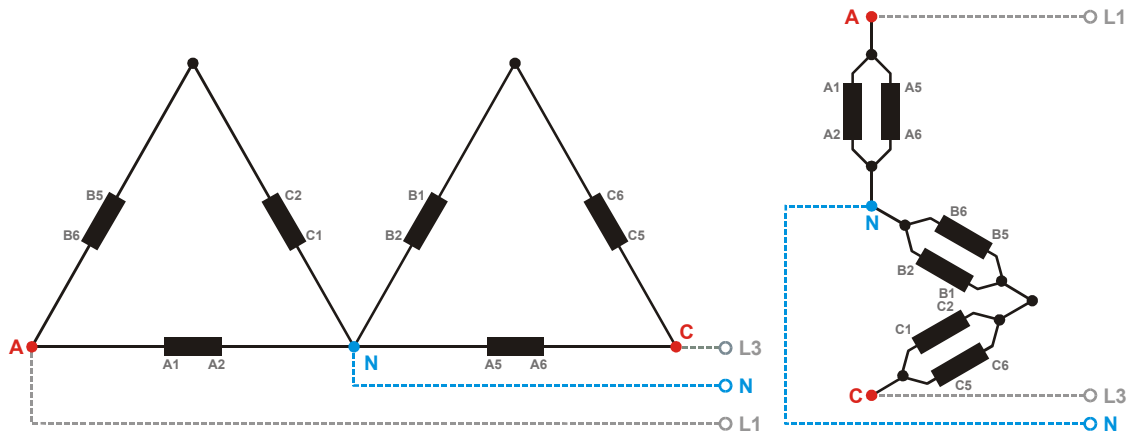

Figure 5-9: Voltage measuring - source 1 PT windings, 1ph 3w

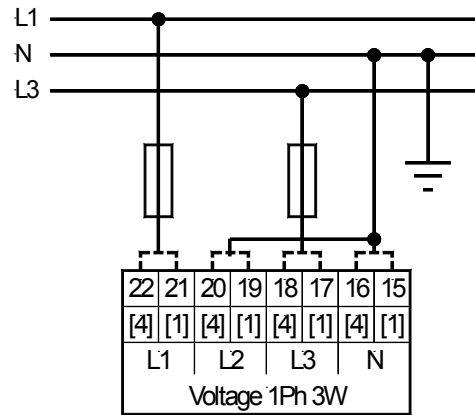

Figure 5-10: Voltage measuring -source 1 measuring inputs, 1ph 3w

1p 3w	Wiring terminals								Note
	Rated voltage (range)	[1] 100 V (50 to 130 V _{eff})				[4] 400 V (131 to 480 V _{eff})			
Measuring range (max.)	[1] 0 to 150 Vac				[4] 0 to 600 Vac				
DTSC-200 terminal	21	19	17	15	22	20	18	16	
Phase	L1	N	L3	N	L1	N	L3	N	

Table 5-7: Voltage measuring - terminal assignment - source 1, 1ph 3w

3 For different voltage systems, different wiring terminals have to be used. Incorrect measurements are possible if both voltage systems use the same N terminal.

Voltage Measuring: Source 1, parameter setting '1ph 2w' (1phase, 2wire)

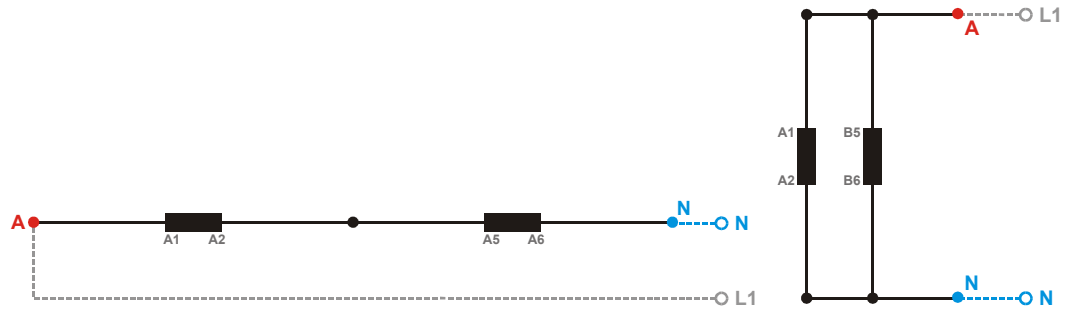

Figure 5-11: Voltage measuring - source 1 PT windings, 1ph 2w

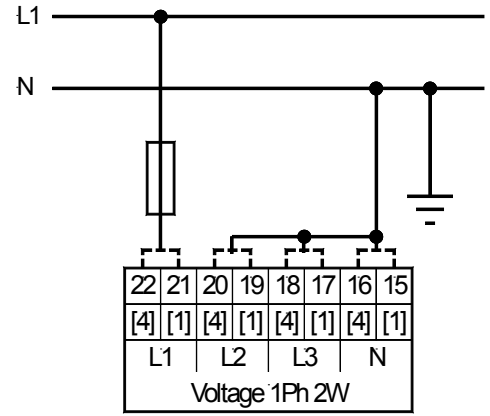

Figure 5-12: Voltage measuring -source 1 measuring inputs, 1ph 2w

1ph 2w	Wiring terminals								Note
	Rated voltage (range)	[1] 100 V (50 to 130 V _{eff})				[4] 400 V (131 to 480 V _{eff})			
Measuring range (max.)	[1] 0 to 150 Vac				[4] 0 to 600 Vac				
DTSC-200 terminal	21	19	17	15	22	20	18	16	
Phase	L1	N	N	N	L1	N	N	N	

Table 5-8: Voltage measuring - terminal assignment - source 1, 1ph 2w

Voltage Measuring: Source 2

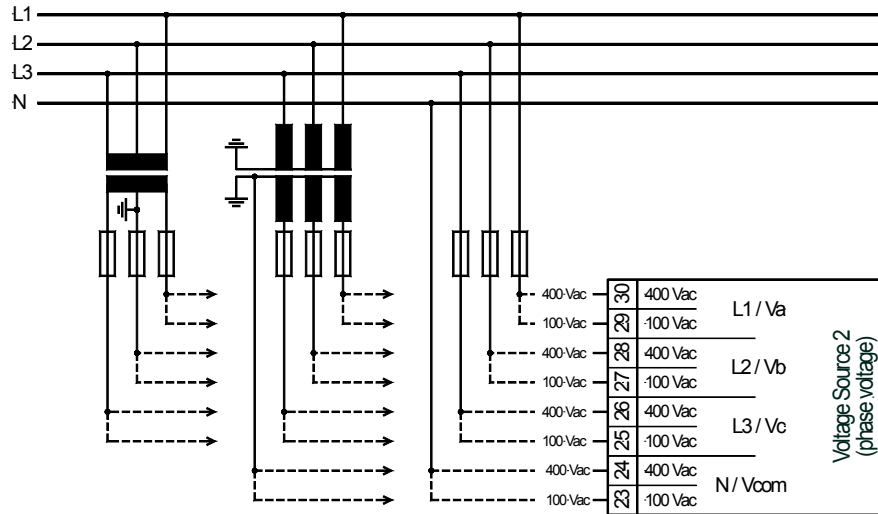

Figure 5-13: Voltage measuring - source 2

Terminal	Description		A _{max}
23	Source 2 voltage - phase N	100 Vac	2.5 mm ²
24		400 Vac	2.5 mm ²
25	Source 2 voltage - phase L3	100 Vac	2.5 mm ²
26		400 Vac	2.5 mm ²
27	Source 2 voltage - phase L2	100 Vac	2.5 mm ²
28		400 Vac	2.5 mm ²
29	Source 2 voltage - phase L1	100 Vac	2.5 mm ²
30		400 Vac	2.5 mm ²

Table 5-9: Voltage measuring - terminal assignment - source 2 voltage



NOTE

The 100 V input terminals must be used, if parameter "S2 voltage transf. secondary" (refer to Configuration Manual 37386) is configured with a value between 50 and 130 V for proper measurement.

The 400 V input terminals must be used, if parameter "S2 voltage transf. secondary" (refer to Configuration Manual 37386) is configured with a value between 131 and 480 V for proper measurement.

Voltage Measuring: Source 2, parameter setting '3ph 4w' (3phase, 4wire)

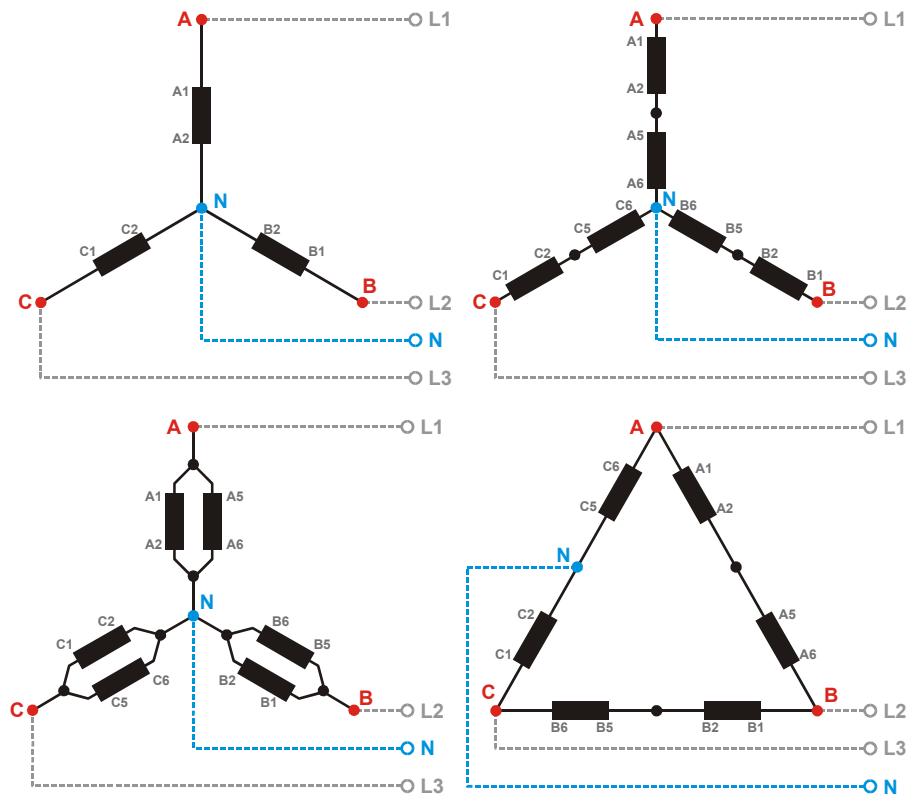

Figure 5-14: Voltage measuring - source 2 PT windings, 3ph 4w

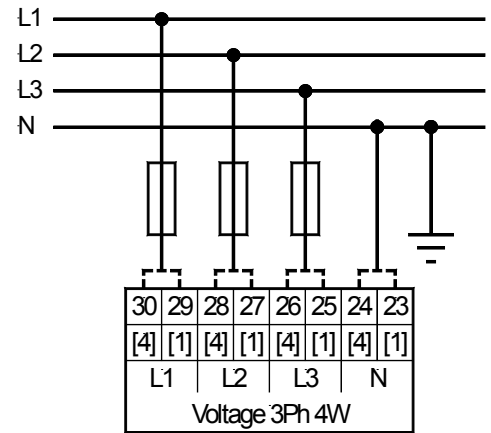

Figure 5-15: Voltage measuring -source 2 measuring inputs, 3ph 4w

3ph 4w	Wiring terminals								Note
	Rated voltage (range)	[1] 100 V (50 to 130 V _{eff})				[4] 400 V (131 to 480 V _{eff})			
Measuring range (max.)	[1] 0 to 150 Vac				[4] 0 to 600 Vac				
DTSC-200 terminal	29	27	25	23	30	28	26	24	
Phase	L1	L2	L3	N	L1	L2	L3	N	

Table 5-10: Voltage measuring - terminal assignment - source 2, 3ph 4w

4 For different voltage systems, different wiring terminals have to be used. Incorrect measurements are possible if both voltage systems use the same N terminal.

Voltage Measuring: Source 2, parameter setting '3ph 3w' (3phase, 3wire)

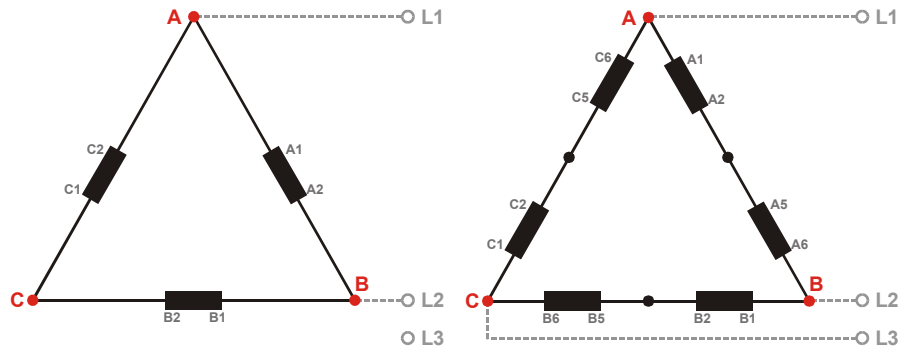

Figure 5-16: Voltage measuring - source 2 PT windings, 3ph 3w

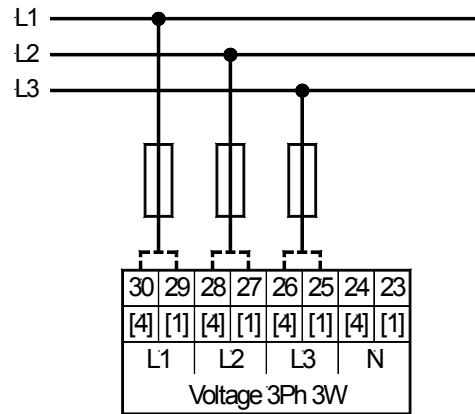

Figure 5-17: Voltage measuring -source 2 measuring inputs, 3ph 3w

3ph 3w	Wiring terminals								Note
	Rated voltage (range)	[1] 100 V (50 to 130 V _{eff})				[4] 400 V (131 to 480 V _{eff})			
Measuring range (max.)	[1] 0 to 150 Vac				[4] 0 to 600 Vac				
DTSC-200 terminal	29	27	25	23	30	28	26	24	
Phase	L1	L2	L3	---	L1	L2	L3	---	

Table 5-11: Voltage measuring - terminal assignment - source 2, 3ph 3w

5 For different voltage systems, different wiring terminals have to be used.

Voltage Measuring: Source 2, parameter setting '1ph 3w' (1phase, 3wire)

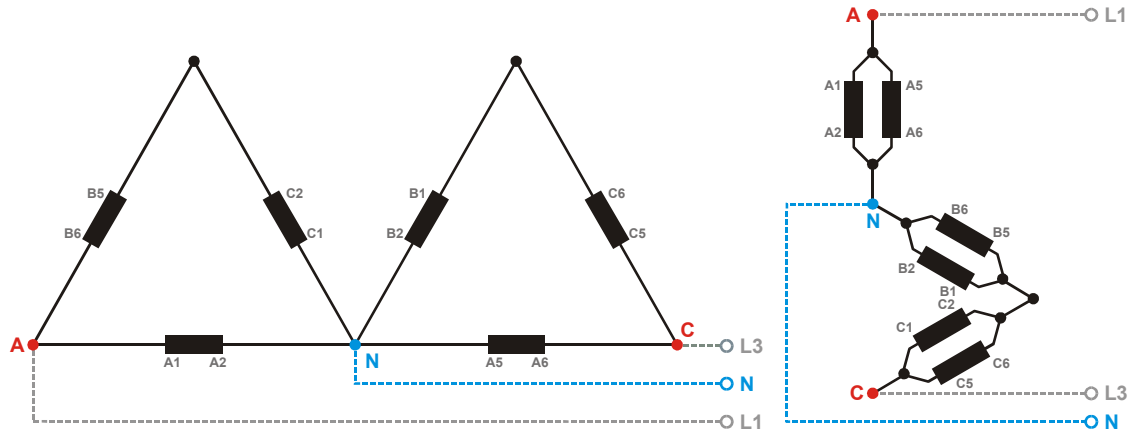

Figure 5-18: Voltage measuring - source 2 PT windings, 1ph 3w

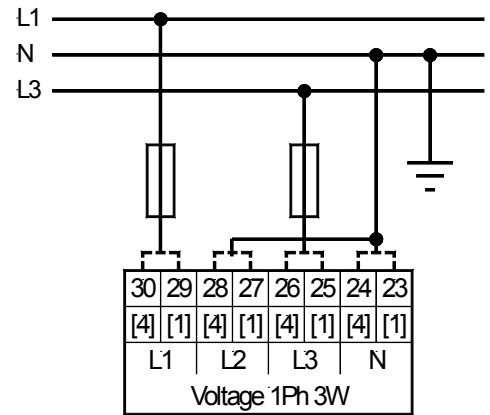

Figure 5-19: Voltage measuring -source 2 measuring inputs, 1ph 3w

1p 3w	Wiring terminals								Note
	Rated voltage (range)	[1] 100 V (50 to 130 V _{eff})				[4] 400 V (131 to 480 V _{eff})			
Measuring range (max.)	[1] 0 to 150 Vac				[4] 0 to 600 Vac				
DTSC-200 terminal	29	27	25	23	30	28	26	24	
Phase	L1	N	L3	N	L1	N	L3	N	

Table 5-12: Voltage measuring - terminal assignment - source 2, 1ph 3w

6 For different voltage systems, different wiring terminals have to be used. Incorrect measurements are possible if both voltage systems use the same N terminal.

Voltage Measuring: Source 2, parameter setting '1ph 2w' (1phase, 2wire)

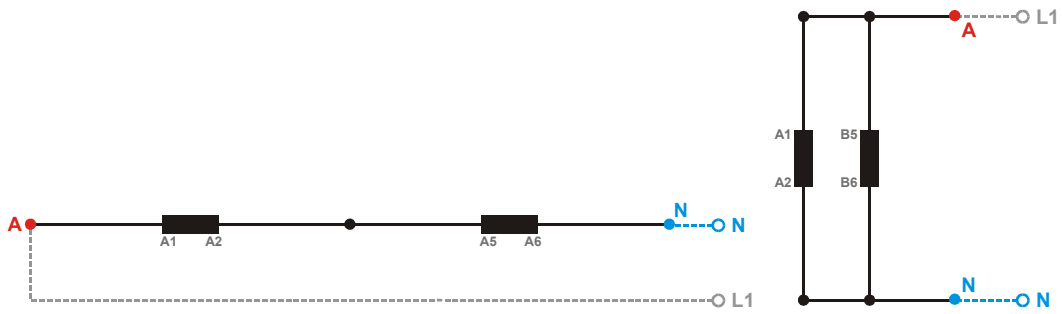

Figure 5-20: Voltage measuring - source 2 PT windings, 1ph 2w

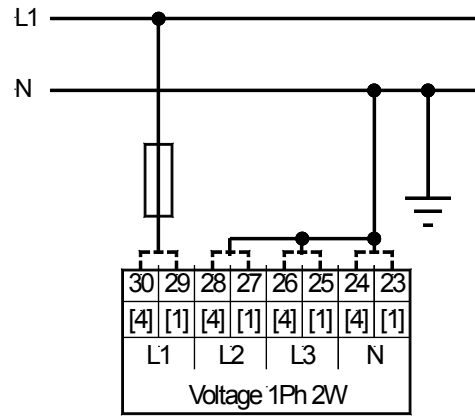

Figure 5-21: Voltage measuring -source 2 measuring inputs, 1ph 2w

1p 2w	Wiring terminals								Note
	Rated voltage (range)	[1] 100 V (50 to 130 V _{eff})				[4] 400 V (131 to 480 V _{eff})			
Measuring range (max.)	[1] 0 to 150 Vac				[4] 0 to 600 Vac				
DTSC-200 terminal	29	27	25	23	30	28	26	24	
Phase	L1	N	N	N	L1	N	N	N	

Table 5-13: Voltage measuring - terminal assignment - source 2, 1ph 2w

Current Measuring



CAUTION

Before disconnecting the current transformer/CT secondary connections or the connections of the current transformer/CT at the device, ensure that the current transformer/CT is short-circuited.

Load



NOTE

Please connect the wires of the current transformer "L (x)" as near as possible to the unit.



NOTE

Generally, one line of the current transformers secondary is to be grounded.

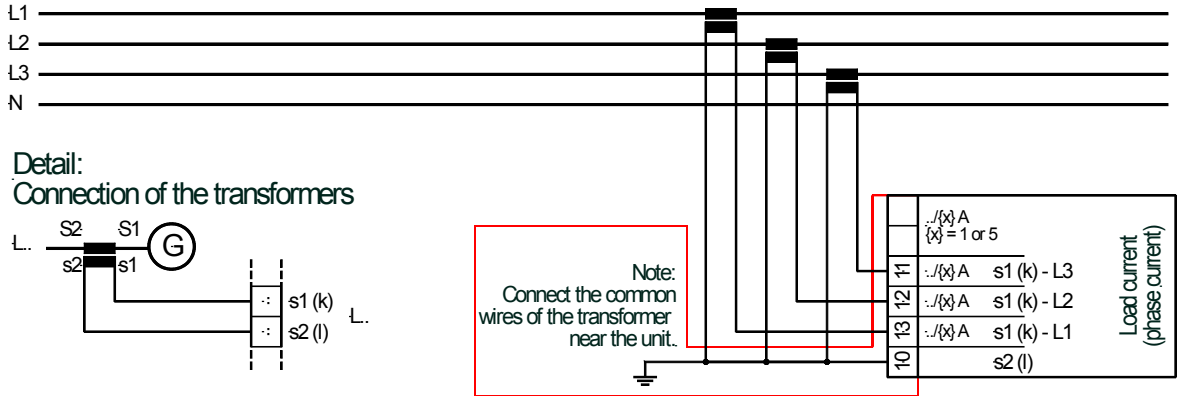

Figure 5-22: Current measuring - load

Terminal	Description	A _{max}
10	Load current - phases L1/L2/L3 - transformer terminals x2 (l)	2.5 mm ²
11	Load current - phase L3 - transformer terminal s1 (k)	2.5 mm ²
12	Load current - phase L2 - transformer terminal s1 (k)	2.5 mm ²
13	Load current - phase L1 - transformer terminal s1 (k)	2.5 mm ²

Table 5-14: Current measuring - terminal assignment - load current

Current Measuring: Load, parameter setting 'L1 L2 L3'

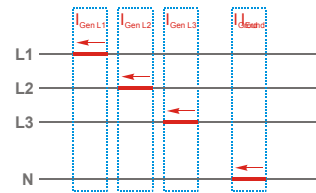

Figure 5-23: Current measuring - load, L1 L2 L3

L1 L2 L3	Wiring terminals				Notes
DTSC-200	13	12	11	10	
Phase	L1	L2	L3	GND	

Table 5-15: Current measuring - terminal assignment - load, L1 L2 L3

Current Measuring: Load, parameter setting 'Phase L1', 'Phase L2' & 'Phase L3'

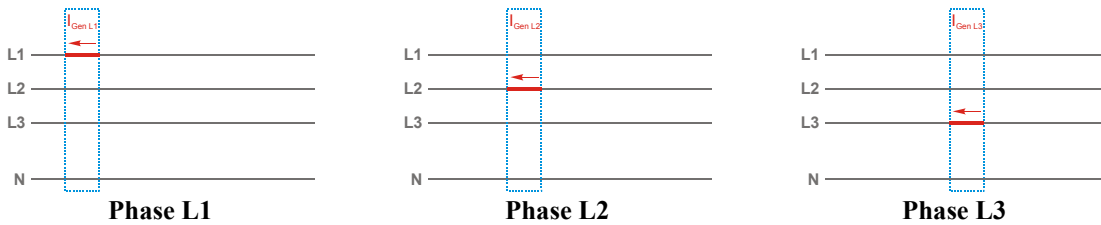

Figure 5-24: Current measuring - load, Phase Lx

	Wiring terminals				Notes
Phase L1					
DTSC-200	13	12	11	10	
Phase	L1	---	---	GND	
Phase L2					
DTSC-200	13	12	11	10	
Phase	---	L2	---	GND	
Phase L3					
DTSC-200	13	12	11	10	
Phase	---	---	L3	GND	

Table 5-16: Current measuring - terminal assignment - load, Phase Lx

Discrete Inputs



Discrete Inputs: Bipolar Signals

The discrete inputs are electrically isolated allowing for a bipolar connection. The discrete inputs are able to handle positive or negative signals.



NOTE

All discrete inputs must use the same polarity, either positive or negative signals, due to the common ground.

Discrete Inputs: Positive / Negative Signal

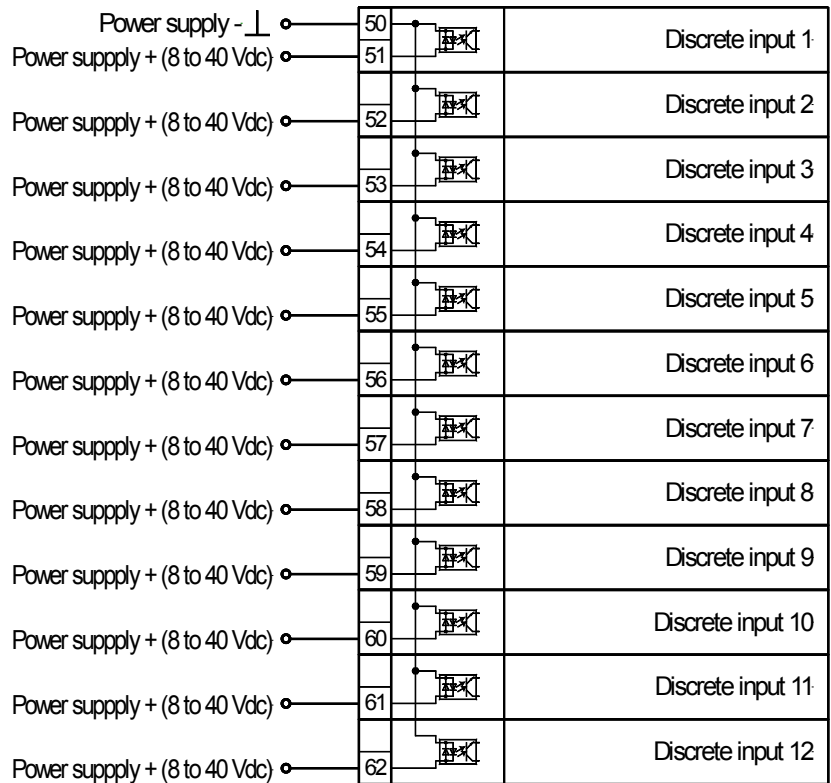

Figure 5-25: Discrete inputs - alarm/control input - positive signal

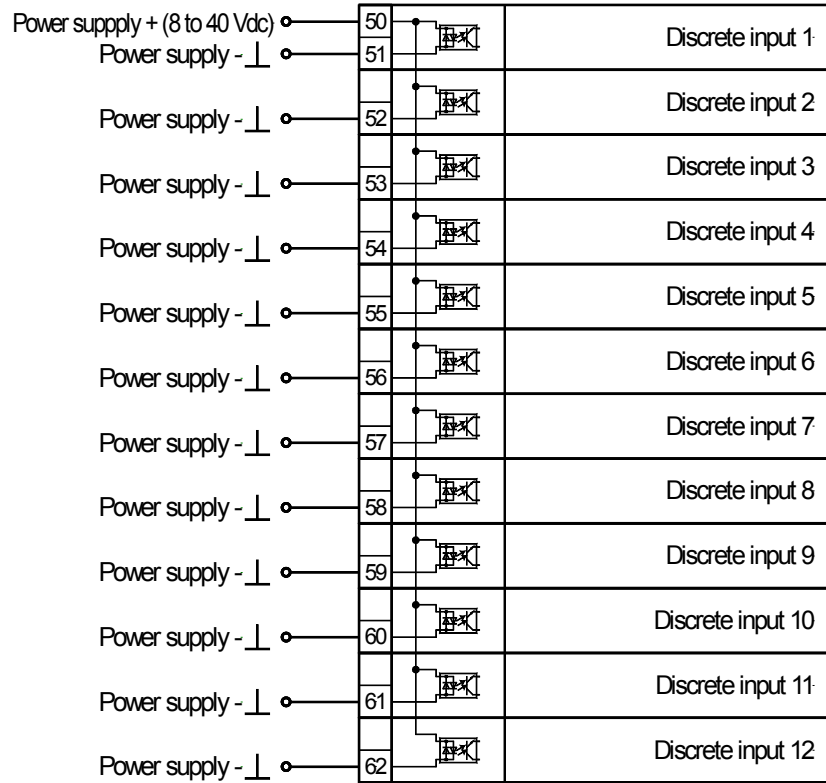

Figure 5-26: Discrete inputs - alarm/control input - negative signal

Terminal Com.	Signal	Description	Type ↴	A _{max}
50	51	Discrete input [DI 1] [S1] Reply from ATS limit switch: Breaker in source 1 position	NC	2.5 mm ²
	52	Discrete input [DI 2] [S2] Reply from ATS limit switch: Breaker in source 2 position	NC	2.5 mm ²
	53	Discrete input [DI 3] [S1O] Reply from ATS limit switch: Breaker in source 2 open position	NC	2.5 mm ²
	54	Discrete input [DI 4] [S2O] Reply from ATS limit switch: Breaker in source 1 open position	NC	2.5 mm ²
	55	Discrete input [DI 5] Inhibit ATS	SW (NC)	2.5 mm ²
	56	Discrete input [DI 6] Alarm input (programmable)	SW	2.5 mm ²
	57	Discrete input [DI 7] Alarm input (programmable)	SW	2.5 mm ²
	58	Discrete input [DI 8] Alarm input (programmable)	SW	2.5 mm ²
	59	Discrete input [DI 9] Alarm input (programmable)	SW	2.5 mm ²
	60	Discrete input [DI 10] Alarm input (programmable)	SW	2.5 mm ²
	61	Discrete input [DI 11] Alarm input (programmable)	SW	2.5 mm ²
	62	Discrete input [DI 12] Alarm input (programmable)	SW	2.5 mm ²

SW-switchable via the software, [NO]-type 1 (N.O./make contact), [NC] -type 2 (N.C./break contact)

Table 5-17: Discrete input - terminal assignment - alarm/control inputs

NOTE
 The discrete inputs for the breaker position reply messages (DIs 1 through 4) are fixed to N.C. and are evaluated as N.C., i.e. the breaker is considered as "in position" if the respective DI is de-energized.

Discrete Inputs: Operation Logic

Discrete inputs may be configured to normally open (N.O.) or normally closed (N.C.) states. In the state N.O., no potential is present during normal operation; if a control operation is performed, the input is energized. In the state N.C., a potential is continuously present during normal operation; if a control operation is performed, the input is de-energized.

The N.O. or N.C. contacts may be connected to the signal terminal as well as to the ground terminal of the discrete input. See previous chapter Discrete Inputs: Bipolar Signals on page 27 for details.

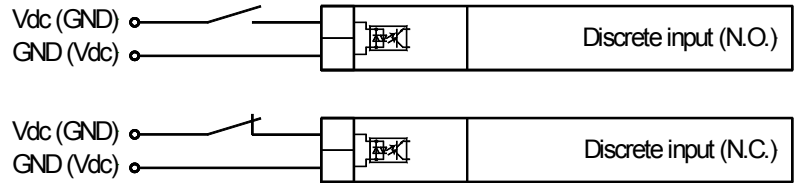

Figure 5-27: Discrete inputs - alarm/control inputs - operation logic

Discrete Outputs (Control Outputs And *LogicsManager*)

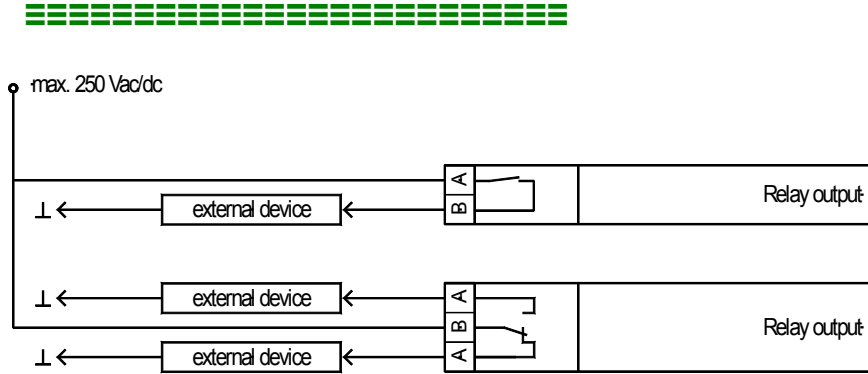

Figure 5-28: Discrete outputs

Terminal Term.	Com.	Description	A_{max}	
A	B	Form A, common contact Type ⚡		
32	31	Discrete output [R 1] <i>LogicsManager</i>	SW	2.5 mm ²
33		Discrete output [R 2] <i>LogicsManager</i>	SW	2.5 mm ²
34		Discrete output [R 3] <i>LogicsManager</i>	SW	2.5 mm ²
A	B	Form C, separate contacts Type ⚡		
35	36	Discrete output [R 4] <i>LogicsManager</i>	NC	2.5 mm ²
37		Discrete output [R 4]	NO	2.5 mm ²
39	40	Discrete output [R 5] Engine start	NO	2.5 mm ²
41		Discrete output [R 5]	NC	2.5 mm ²
A	B	Form A, separate contacts Type ⚡		
43	42	Discrete output [R 6] [C1] Command: close to source 1 position	NO	2.5 mm ²
45	44	Discrete output [R 7] [C2] Command: close to source 2 position	NO	2.5 mm ²
47	46	Discrete output [R 8] [C10] Command: open from source 1 to neutral position	NO	2.5 mm ²
49	48	Discrete output [R 9] [C20] Command: open from source 2 to neutral position	NO	2.5 mm ²

LogicsManager..using the function *LogicsManager* it is possible to freely program the relays SW-switchable via the software, [NO]-type 1 (N.O./make contact), [NC]-type 1 (N.C./break contact)

Table 5-18: Discrete outputs - terminal assignment

Interfaces



RS-485 Modbus RTU Slave

	5	6	7	8
	RS-485-A	RS-485-B	RS-485-A'	RS-485-B'
Interface	RS-485 Modbus RTU Slave (isolated, full duplex)			

Figure 5-29: Interface

Terminal				Description
5	6	7	8	
RS-485-A (TxD-)	RS-485-B (TxD+)	RS-485-A' (RxD-)	RS-485-B' (RxD+)	RS-485, Modbus RTU Slave

Table 5-19: RS-485 Modbus interface - terminal assignment

Half-Duplex with Modbus on RS-485

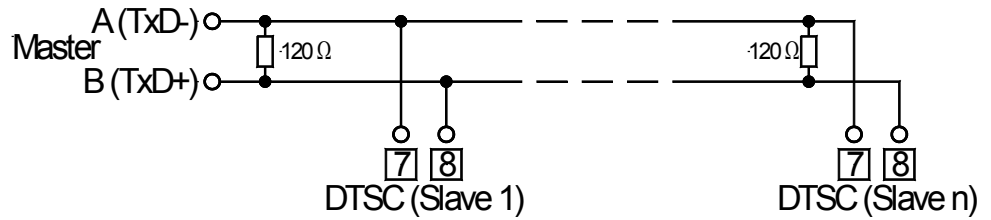

Figure 5-30: RS-485 Modbus - connection for half-duplex operation

Full-Duplex with Modbus on RS-485

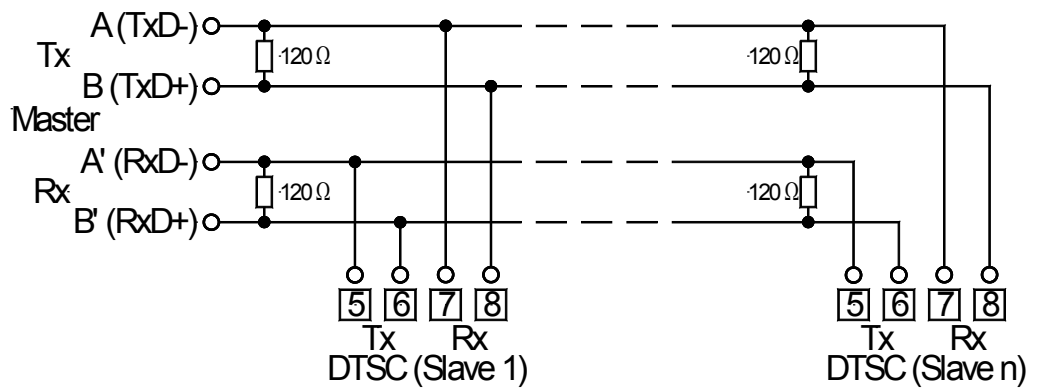

Figure 5-31: RS-485 Modbus - connection for full-duplex operation



NOTE

Please note that the DTSC must be configured for half- or full-duplex configuration (refer to parameter 3173 in the Configuration Manual 37385).

CAN Bus (*FlexCAN*)

Wiring

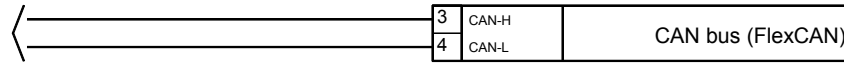

Figure 5-32: Interfaces - CAN bus (*FlexCAN*)

Terminal	Description	A _{max}
3	CAN bus (<i>FlexCAN</i>)	CAN-H 2.5 mm ²
4		CAN-L 2.5 mm ²

Table 5-20: CAN bus interface - terminal assignment

Shielding

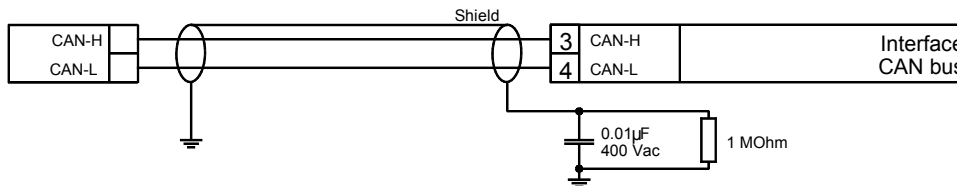
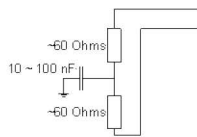

Figure 5-33: Interfaces - CAN bus - wiring of shielding



NOTE

Please note that the CAN bus must be terminated with a resistor, which corresponds to the impedance of the cable (e.g. 120 Ohms, 1/4 W) at both ends. The termination resistor is connected between CAN-H and CAN-L.



i
Note:
We recommend for very critical EMC conditions (many noise sources with high noise levels) and high transmission rates to use the "Split Termination Concept", i.e. dividing the termination resistor into 2x60 Ohms with a center tap connected to ground via a capacitor of 10 - 100 nF.

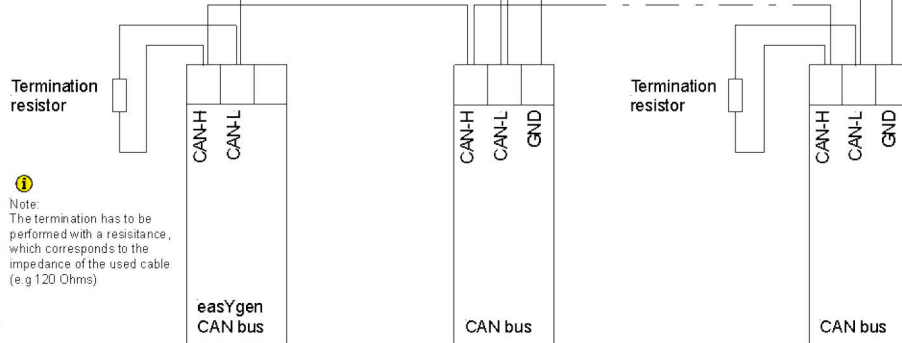

Figure 5-34: Interfaces - CAN bus - termination

Possible CAN Bus Problems

If no data is transmitted on the CAN bus, check the following for common CAN bus communication problems:

- T structure bus is utilized
- CAN-L and CAN-H are interchanged
- Not all devices on the bus are using identical Baud rates
- Terminating resistor are missing
- Baud rate to high for wiring length
- The CAN bus cable is co-routed with power cables

Woodward recommends the use of twisted-pair cables for the CAN bus (i.e.: Lappkabel Unitronic LIYCY (TP) 2×2×0.25, UNITRONIC-Bus LD 2×2×0.22).

Maximum CAN bus Length

The maximum length of the communication bus wiring is dependent on the configured Baud rate. Refer to Table 5-21 for the maximum bus length (Source: CANopen; Holger Zeltwanger (Hrsg.); 2001 VDE VERLAG GMBH, Berlin und Offenbach; ISBN 3-8007-2448-0).

Baud rate	Max. length
1000 kbit/s	25 m
800 kbit/s	50 m
500 kbit/s	100 m
125 kbit/s	250 m
50 kbit/s	1000 m
20 kbit/s	2500 m

Table 5-21: Maximum CAN bus length

The maximum specified length for the communication bus wiring might not be achieved if poor quality wire is utilized, there is high contact resistance, or other conditions exist. Reducing the baud rate may overcome these issues.

DPC - Direct Configuration Cable

The easYgen provides a configuration interface for connecting a computer via the DPC (direct configuration cable). The configuration interface is the RJ45 socket on the side of the easYgen housing.

 **NOTE**
Configuration with the direct configuration cable DPC (P/N 5417-557) is possible. A laptop/PC, the DPC cable, the program LeoPC1 version 3.1.1 or higher (included on CD Rom with control unit), and the proper configuration files are required.

 **NOTE**
The connection cable delivered with the DPC must be used between DPC and easYgen to ensure proper functionality of the easYgen. An extension or utilization of different cable types for the connection between easYgen and DPC may result a malfunction of the easYgen. This may possibly result in damage to components of the system. If an extension of the data connection line is required, only the serial cable (RS-232) between DPC and laptop/PC may be extended. It is recommended to use an industry standard cable for this.

 **NOTE**
For a continuous operation with the direct configuration cable DPC (e.g. remote control of the easYgen), it is required to use at least revision F (P/N 5417-557 Rev. F) of the DPC. When using a DPC of an earlier revision, problems may occur in continuous operation. It is recommended to use an industry standard serial (RS-232) cable to connect the DPC with the laptop/PC for continuous operation. The shield connector (6.3mm tab connector) at the DPC of revision F (P/N 5417-557 Rev. F) and above must be connected to ground.

Chapter 6. Technical Data

Nameplate -----

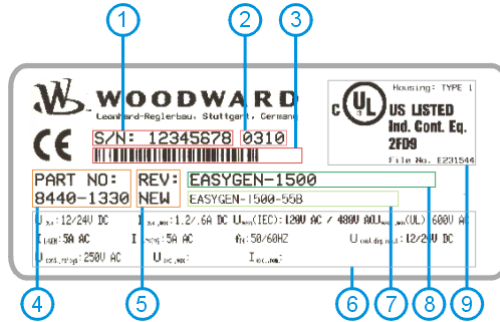

1	S/N	Serial number (numerical)
2	S/N	Date of production (YYMM)
3	S/N	Serial number (Barcode)
4	P/N	Item number
5	REV	Item revision number
6	Details	Technical data
7	Type	Description (short)
8	Type	Description (long)
9	UL	UL sign

Measuring values, voltages ----- \wedge/Δ

- Measuring voltages

100 V	Rated value (V_{rated})	69/120 Vac
	Maximum value (V_{max})	max. 86/150 Vac
	Rated voltage phase – ground	150 Vac
	Rated surge voltage	2.5 kV

400 V	Rated value (V_{rated})	277/480 Vac
	Maximum value (V_{max})	max. 346/600 Vac
	Rated voltage phase – ground	300 Vac
	Rated surge voltage	4.0 kV

- Linear measuring range	1.25 × V_{rated}
- Measuring frequency	50/60 Hz (40.0 to 70.0 Hz)
- Accuracy	Class 1
- Input resistance per path	100 V 0.498 MΩ
	400 V 2.0 MΩ
- Maximum power consumption per path	< 0.15 W

Measuring values, currents ----- **isolated**

- Measuring current	[1] Rated value (I_{rated})	.../1 A
	[5] Rated value (I_{rated})	.../5 A
- Accuracy	Class 1	
- Linear measuring range	Load (terminals 10 through 13)	3.0 × I_{rated}
- Maximum power consumption per path		< 0.15 VA
- Rated short-time current (1 s)	[1]	50.0 × I_{rated}
	[5]	10.0 × I_{rated}

Ambient variables -----

- Power supply	12/24 Vdc (8 to 40 Vdc; not buffered)	
	Battery ground (terminal 2) must be grounded to the chassis	
- Inrush current	max. 50 A peak, 1 ms	
- Input capacitance	2000 μF	
- Intrinsic consumption	max. 8 W	
	in power save mode (backlight, relays off)	3 W
- Degree of pollution	2	

- Housing** -----
- Type..... easYpack
 - Dimensions (W × H × D)..... 219 × 171 × 61 mm (8.6 × 6.7 × 2.4 in)
 - Front cutout (W × H)..... 186 [+1.1] × 138 [+1.0] mm
 - Material..... glass fiber-reinforced plastic
 - Wiring..... screw-plug-terminals 14 AWG / 2.5 mm²
 - Recommended tightening torque 5 to 7 pound-force inches / 0.5 to 0.8 Nm
use 60/75 °C copper wire 14 AWG / 2.5 mm² only
use class 1 wire only or equivalent
 - Weight approx. 800 g (1.75 lb)

- Protection** -----
- Protection system..... IP54 from front with clamp kit
IP65 from front with screw kit
IP20 from back
 - Front folio..... insulating surface
 - EMC test (CE) tested according to applicable EN guidelines
 - Listings CE marking; UL listing for ordinary locations
 - Type approval..... UL/cUL listed, Ordinary Locations, File No.: 231544

Chapter 7. Environmental Data



- Dynamics** -----
- Frequency Range – Sine Sweep 5Hz to 150Hz
 - Acceleration..... 4G
 - Frequency Range - Random 10Hz to 500Hz
 - Power Density 0,015G²/Hz
 - RMS Value 1,04 Grms
 - Standards.....
 - EN 60255-21-1 (EN 60068-2-6, Fc)
 - EN 60255-21-3
 - Lloyd’s Register, Vibration Test2
 - SAEJ1455 Chasis Data
 - MIL-STD 810F, M514.5A, Cat.4,
 - Truck/Trailer tracked-restrained cargo, Fig. 514.5-C1
- Shock** -----
- 40G, Sawtooth Puls, 11ms
 - Standards.....
 - EN 60255-21-2
 - MIL-STD 810F, M516.5, Procedure 1
- Temperature** -----
- Cold, Dry Heat (storage) -30°C (-22°F) / 80°C (176°F)
 - Cold, Dry Heat (operating)..... -20°C (-4°F) / 60 °C (140°F)
 - Standards.....
 - IEC 60068-2-2, Test Bb and Bd
 - IEC 60068-2-1, Test Ab and Ad
- Humidity** -----
- 60°C, 95% RH, 5 days
 - Standards.....
 - IEC 60068-2-30, Test Db
- Altitude** -----
- Maximum operating altitude 2000 m (6,500 ft)

Chapter 8. Accuracy

Measuring value		Display	Accuracy	Notes
Frequency				
Source 1	$f_{L1N}, f_{L2N}, f_{L3N}$	15.0 to 85.0 Hz	0.1 %	-
Source 2	$f_{L1N}, f_{L2N}, f_{L3N}$	40.0 to 85.0 Hz	0.1 %	-
Voltage				
Source 1	$V_{L1N}, V_{L2N}, V_{L3N}$	0 to 650 kV	1 %	Transformer ratio selectable
Source 2	$V_{L1N}, V_{L2N}, V_{L3N}$	0 to 650 kV	1 %	Transformer ratio selectable
Current				
Load	I_{L1}, I_{L2}, I_{L3}	0 to 32,000 A	1 %	-
Max. value	I_{L1}, I_{L2}, I_{L3}	0 to 32,000 A	1 %	Slave pointer
Real power				
Current total real power value		-2 to 2 GW	2 %	Accuracy depends on the configured transformer ratios
Reactive power				
Current value in L1, L2, L3		-2 to 2 Gvar	2 %	Accuracy depends on the configured transformer ratios
cos ϕ				
Current value cos ϕ L1		lag0.00 to 1.00 to lead0.00	2 %	-
Miscellaneous				
Real energy		0 to 4,200 GWh		not calibrated
Battery voltage		6.5 to 40 V	1 %	-

Reference conditions (to measure the accuracy):

- Input voltagesinusoidal rated voltage
- Input currentsinusoidal rated current
- Frequencyrated frequency +/- 2 %
- Power supplyrated voltage +/- 2 %
- Power factor cos ϕ 1.00
- Ambient temperature23 °C +/- 2 K
- Warm-up period.....20 minutes

Appendix A. Recommended Power Supply Units

Woodward recommends the use of the following external power supply units:

- Mean Well: DR-30-24
- Phoenix Contact: MINI-PS-100-240AC/24DC/1

An external buffered power supply solution may be achieved using the following devices:

- 2x Phoenix Contact: MINI-PS-100-240AC/24DC/1
- 1x Phoenix Contact: Quint-Buffer/24DC/20

We appreciate your comments about the content of our publications.
Please send comments to: stgt-documentation@woodward.com
Please include the manual number from the front cover of this publication.



Woodward GmbH
Handwerkstrasse 29 - 70565 Stuttgart - Germany
Phone +49 (0) 711 789 54-510 • Fax +49 (0) 711 789 54-101
stgt-info@woodward.com

Homepage

<http://www.woodward.com>

Woodward has company-owned plants, subsidiaries, and branches, as well as authorized distributors and other authorized service and sales facilities throughout the world.

Complete address/phone/fax/e-mail information for all locations is available on our website (www.woodward.com).

2013/07/Stuttgart