

37482B

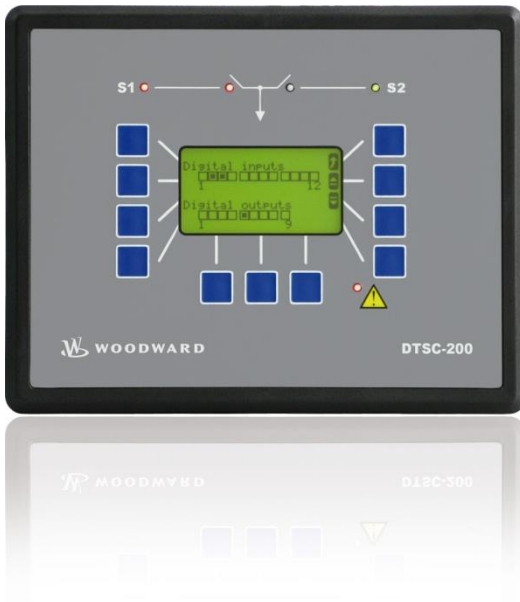

DTSC-200 ATS Controller



Installation
Software Version 2.0xxx

Manual 37482B

**WARNING**

Read this entire manual and all other publications pertaining to the work to be performed before installing, operating, or servicing this equipment. Practice all plant and safety instructions and precautions. Failure to follow instructions can cause personal injury and/or property damage.

The engine, turbine, or other type of prime mover should be equipped with an overspeed (overtemperature, or overpressure, where applicable) shutdown device(s), that operates totally independently of the prime mover control device(s) to protect against runaway or damage to the engine, turbine, or other type of prime mover with possible personal injury or loss of life should the mechanical-hydraulic governor(s) or electric control(s), the actuator(s), fuel control(s), the driving mechanism(s), the linkage(s), or the controlled device(s) fail.

Any unauthorized modifications to or use of this equipment outside its specified mechanical, electrical, or other operating limits may cause personal injury and/or property damage, including damage to the equipment. Any such unauthorized modifications: (i) constitute "misuse" and/or "negligence" within the meaning of the product warranty thereby excluding warranty coverage for any resulting damage, and (ii) invalidate product certifications or listings.

**CAUTION**

To prevent damage to a control system that uses an alternator or battery-charging device, make sure the charging device is turned off before disconnecting the battery from the system.

Electronic controls contain static-sensitive parts. Observe the following precautions to prevent damage to these parts.

- Discharge body static before handling the control (with power to the control turned off, contact a grounded surface and maintain contact while handling the control).
- Avoid all plastic, vinyl, and Styrofoam (except antistatic versions) around printed circuit boards.
- Do not touch the components or conductors on a printed circuit board with your hands or with conductive devices.

**OUT-OF-DATE PUBLICATION**

This publication may have been revised or updated since this copy was produced. To verify that you have the latest revision, be sure to check the Woodward website:

<http://www.woodward.com/pubs/current.pdf>

The revision level is shown at the bottom of the front cover after the publication number. The latest version of most publications is available at:

<http://www.woodward.com/publications>

If your publication is not there, please contact your customer service representative to get the latest copy.

Important definitions**WARNING**

Indicates a potentially hazardous situation that, if not avoided, could result in death or serious injury.

**CAUTION**

Indicates a potentially hazardous situation that, if not avoided, could result in damage to equipment.

**NOTE**

Provides other helpful information that does not fall under the warning or caution categories.

Woodward reserves the right to update any portion of this publication at any time. Information provided by Woodward is believed to be correct and reliable. However, Woodward assumes no responsibility unless otherwise expressly undertaken.

© Woodward
All Rights Reserved.

Revision History

Rev.	Date	Editor	Changes
B	2026-03-02	MK	Correction: <ul style="list-style-type: none"> Table 5-17: corrected description of Discrete input DI03 and DI04 Manual: <ul style="list-style-type: none"> Updated email address
A	2013-07-03	GG	Correction: <ul style="list-style-type: none"> Pin assignment CAN-H/-L corrected on page 34. Manual: <ul style="list-style-type: none"> Phone number on rear page updated
NEW	11-11-17	TE	Release Software Version 2.0xxx - Based on 37385A

Content

CHAPTER 1. GENERAL INFORMATION	6
CHAPTER 2. ELECTROSTATIC DISCHARGE AWARENESS	7
CHAPTER 3. HOUSING	8
Panel Cutout	8
Dimensions.....	9
Installation	10
Screw Kit Installation.....	11
CHAPTER 4. WIRING DIAGRAM.....	12
CHAPTER 5. CONNECTIONS	13
Power Supply	14
Function Earth	14
Voltage Measuring (<i>FlexRange</i>)	15
Voltage Measuring: Source 1	15
Voltage Measuring: Source 2	20
Current Measuring	25
Load	25
Discrete Inputs	27
Discrete Inputs: Bipolar Signals	27
Discrete Inputs: Operation Logic	29
Discrete Outputs (Control Outputs And <i>LogicsManager</i>)	30
Interfaces.....	31
RS-485 Modbus RTU Slave	31
Service Port	32
CAN Bus Interfaces (<i>FlexCAN</i>)	34
CHAPTER 6. TECHNICAL DATA.....	36
CHAPTER 7. ENVIRONMENTAL DATA	39
CHAPTER 8. ACCURACY	40
APPENDIX A. RECOMMENDED POWER SUPPLY UNITS	41

Illustrations and Tables

Illustrations

Figure 3-1: Housing - panel-board cutout.....	8
Figure 3-2: Housing - dimensions.....	9
Figure 3-3: Housing - drill plan	11
Figure 4-1: Wiring diagram	12
Figure 5-1: Power supply.....	14
Figure 5-2: Power supply - crank waveform at maximum load	14
Figure 5-3: Earth ground.....	14
Figure 5-4: Voltage measuring - terminal assignment - source 1 voltage	15
Figure 5-5: Voltage measuring -source 1 PT windings, 3Ph 4W	16
Figure 5-6: Voltage measuring -source 1 measuring inputs, 3Ph 4W	16
Figure 5-7: Voltage measuring - source 1 PT windings, 3Ph 3W	17
Figure 5-8: Voltage measuring -source 1 measuring inputs, 3Ph 3W	17
Figure 5-9: Voltage measuring - source 1 PT windings, 1Ph 3W	18
Figure 5-10: Voltage measuring -source 1 measuring inputs, 1Ph 3W	18
Figure 5-11: Voltage measuring - source 1 PT windings, 1Ph 2W	19
Figure 5-12: Voltage measuring -source 1 measuring inputs, 1Ph 2W	19
Figure 5-13: Voltage measuring - source 2	20
Figure 5-14: Voltage measuring - source 2 PT windings, 3Ph 4W	21
Figure 5-15: Voltage measuring -source 2 measuring inputs, 3Ph 4W	21
Figure 5-16: Voltage measuring - source 2 PT windings, 3Ph 3W	22
Figure 5-17: Voltage measuring -source 2 measuring inputs, 3Ph 3W	22
Figure 5-18: Voltage measuring - source 2 PT windings, 1Ph 3W	23
Figure 5-19: Voltage measuring -source 2 measuring inputs, 1Ph 3W	23
Figure 5-20: Voltage measuring -source 2 PT windings, 1Ph 2W	24
Figure 5-21: Voltage measuring -source 2 measuring inputs, 1Ph 2W	24
Figure 5-22: Current measuring - load.....	25
Figure 5-23: Current measuring - load, L1 L2 L3.....	26
Figure 5-24: Current measuring - load, Phase Lx	26
Figure 5-25: Discrete inputs - alarm/control input - positive signal.....	27
Figure 5-26: Discrete inputs - alarm/control input - negative signal.....	28
Figure 5-27: Discrete inputs - alarm/control inputs - operation logic	29
Figure 5-28: Discrete outputs.....	30
Figure 5-29: Interface	31
Figure 5-30: RS-485 Modbus - connection for half-duplex operation	31
Figure 5-31: RS-485 Modbus - connection for full-duplex operation.....	31
Figure 5-32: Service port connector (RJ-45).....	32
Figure 5-33: DPC-USB wiring - schematic	32
Figure 5-34: DPC-RS-232 wiring - schematic	33
Figure 5-35: Interfaces - CAN bus (<i>FlexCAN</i>).....	34
Figure 5-36: Interfaces - CAN bus - wiring of shielding	34
Figure 5-37: Interfaces - CAN bus - termination	34

Tables

Table 1-1: Manual - overview	6
Table 3-1: Housing - panel cutout	8
Table 5-1: Conversion chart - wire size	13
Table 5-2: Power supply - terminal assignment	14
Table 5-3: Earth ground - terminal assignment	14
Table 5-4: Voltage measuring - terminal assignment - source 1	15
Table 5-5: Voltage measuring - terminal assignment - source 1, 3ph 4w	16
Table 5-6: Voltage measuring - terminal assignment - source 1, 3Ph 3W	17
Table 5-7: Voltage measuring - terminal assignment - source 1, 1Ph 3W	18
Table 5-8: Voltage measuring - terminal assignment - source 1, 1Ph 2W	19
Table 5-9: Voltage measuring - terminal assignment - source 2 voltage	20
Table 5-10: Voltage measuring - terminal assignment - source 2, 3Ph 4W	21
Table 5-11: Voltage measuring - terminal assignment - source 2, 3Ph 3W	22
Table 5-12: Voltage measuring - terminal assignment - source 2, 1Ph 3W	23
Table 5-13: Voltage measuring - terminal assignment - source 2, 1Ph 2W	24
Table 5-14: Current measuring - terminal assignment - load current	25
Table 5-15: Current measuring - terminal assignment - load, L1 L2 L3	26
Table 5-16: Current measuring - terminal assignment - load, Phase Lx	26
Table 5-17: Discrete input - terminal assignment - alarm/control inputs	28
Table 5-18: Discrete outputs - terminal assignment	30
Table 5-19: RS-485 Modbus interface - terminal assignment	31
Table 5-20: CAN bus interface - terminal assignment	34
Table 5-21: Maximum CAN bus length	35

Chapter 1.

General Information

Type	English	German
DTSC-200		
DTSC-200 - Installation	this manual ⇔	37482
DTSC-200 - Configuration		37483
DTSC-200 - Operation		37484
DTSC-200 - Application		37485
DTSC-200 - Interfaces		37486

Table 1-1: Manual - overview

Intended Use The unit must only be operated in the manner described by this manual. The prerequisite for a proper and safe operation of the product is correct transportation, storage, and installation as well as careful operation and maintenance.



NOTE

This manual has been developed for a unit fitted with all available options. Inputs/outputs, functions, configuration screens, and other details described, which do not exist on your unit, may be ignored.

The present manual has been prepared to enable the installation and commissioning of the unit. Due to the large variety of parameter settings, it is not possible to cover every combination. The manual is therefore only a guide. In case of incorrect entries or a total loss of functions, the default settings may be taken from the list of parameters enclosed in the configuration manual 37483.

Chapter 2.

Electrostatic Discharge Awareness

All electronic equipment is static-sensitive, some components more than others. To protect these components from static damage, you must take special precautions to minimize or eliminate electrostatic discharges.

Follow these precautions when working with or near the control.

1. Before doing maintenance on the electronic control, discharge the static electricity on your body to ground by touching and holding a grounded metal object (pipes, cabinets, equipment, etc.).
2. Avoid the build-up of static electricity on your body by not wearing clothing made of synthetic materials. Wear cotton or cotton-blend materials as much as possible because these do not store static electric charges as easily as synthetics.
3. Keep plastic, vinyl, and Styrofoam materials (such as plastic or Styrofoam cups, cigarette packages, cellophane wrappers, vinyl books or folders, plastic bottles, etc.) away from the control, modules, and work area as much as possible.
4. **Opening the control cover may void the unit warranty.**
Do not remove the printed circuit board (PCB) from the control cabinet unless absolutely necessary. If you must remove the PCB from the control cabinet, follow these precautions:
 - Ensure that the device is completely voltage-free (all connectors have to be disconnected).
 - Do not touch any part of the PCB except the edges.
 - Do not touch the electrical conductors, connectors, or components with conductive devices or with bare hands.
 - When replacing a PCB, keep the new PCB in the plastic antistatic protective bag it comes in until you are ready to install it. Immediately after removing the old PCB from the control cabinet, place it in the antistatic protective bag.



CAUTION

To prevent damage to electronic components caused by improper handling, read and observe the precautions in Woodward manual 82715, *Guide for Handling and Protection of Electronic Controls, Printed Circuit Boards, and Modules*.

Chapter 3. Housing

Panel Cutout

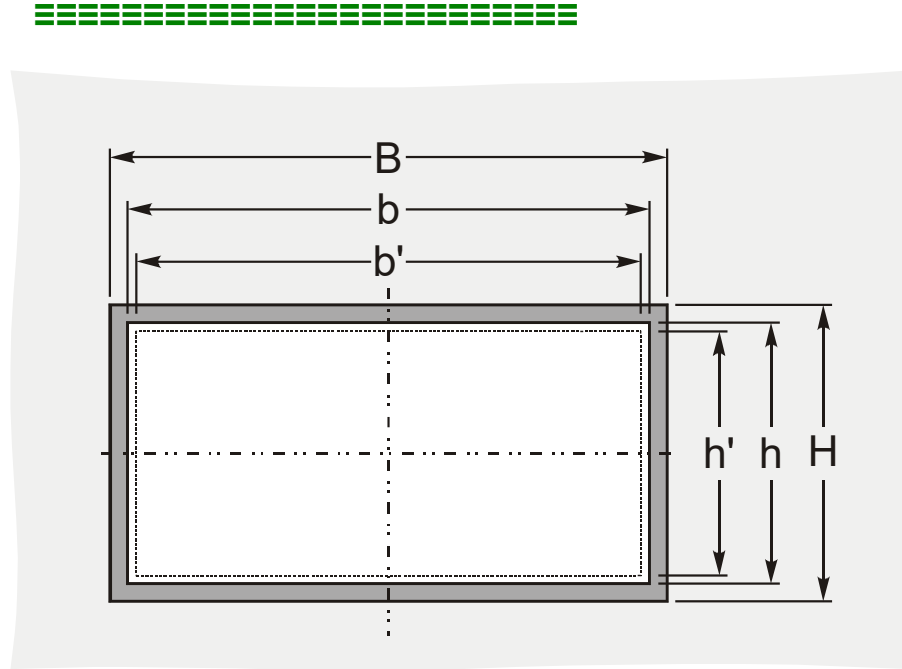

Figure 3-1: Housing - panel-board cutout

Measure	Description		Tolerance
H	Height	Total	171 mm (6.73 in) ---
h		Panel cutout	138 mm (5.43 in) + 1.0 mm (0.04 in)
h'		Housing dimension	136 mm (5.35 in)
B	Width	Total	219 mm (8.62 in) ---
b		Panel cutout	186 mm (7.32 in) + 1.1 mm (0.04 in)
b'		Housing dimension	185 mm (7.28 in)
	Depth	Total	61 mm (2.40 in) ---

Table 3-1: Housing - panel cutout

The maximum permissible corner radius is 3.5 mm (0.14 in).
Refer to Figure 3-3 on page 11 for a cutout drawing.

Dimensions

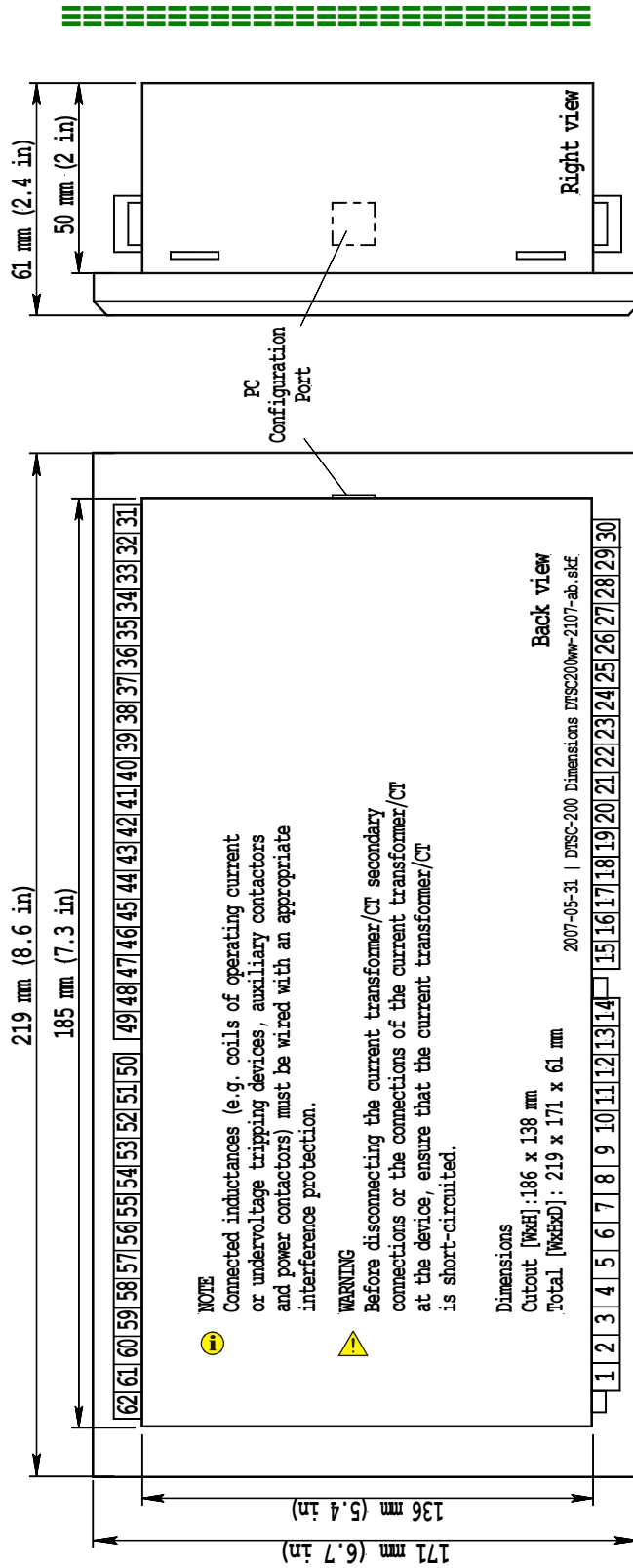

Figure 3-2: Housing - dimensions

Installation



For installation into a panel door with the fastening clamps, please proceed as follows:

1. **Panel cutout**

Cut out the panel according to the dimensions in Figure 3-3.

Note: It is not necessary to drill the holes if the fastening clamps are used.

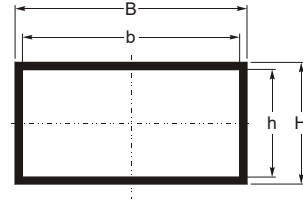

2. **Remove terminals**

Loosen the wire connection terminal screws on the back of the unit and remove the wire connection terminal strip if required.

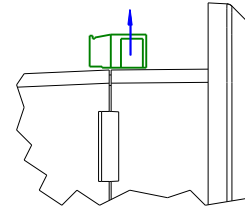

3. **Insert screws in clamps**

Insert the four clamping screws into the clamp inserts from the shown side (opposite of the nut insert) until they are almost flush. Do not completely insert the screws into the clamp inserts.

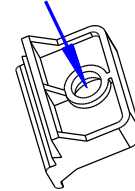

4. **Insert unit into cutout**

Insert the unit into the panel cutout. Verify that the unit fits correctly in the cutout. If the panel cutout is not big enough, enlarge it accordingly.

5. **Attach clamp inserts**

Re-install the clamp inserts by tilting the insert to a 45° angle. (1) Insert the nose of the insert into the slot on the side of the housing. (2) Raise the clamp insert so that it is parallel to the control panel.

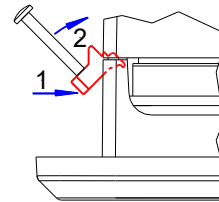

6. **Tighten clamping screws**

Tighten the clamping screws (1) until the control unit is secured to the control panel (2). Over tightening of these screws may result in the clamp inserts or the housing breaking. Do not exceed the recommended tightening torque of 0.1 Nm (0.9 pound-force inches).

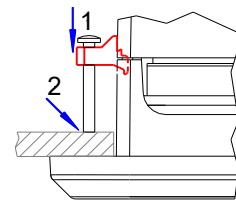

7. **Reattach terminals**

Reattach the wire connection terminal strip (1) and secure them with the side screws.

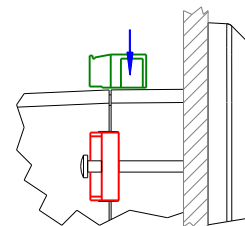

Screw Kit Installation



In order to enhance the protection from front to IP 65, it is possible to fasten the unit with a screw kit instead of the clamp fastener hardware.

Proceed as follows to install the unit using the screw kit:

1. Cut out the panel and drill the holes according to the dimensions in Figure 3-3.
2. Insert the unit into the panel cutout. Verify that the unit fits correctly in the cutout. If the panel cutout is not big enough, enlarge it accordingly.
3. Insert the screws and tighten to 0.6 Nm (5.3 pound-force inches) of torque. Tighten the screws with a cross-wise pattern to ensure even pressure distribution.



NOTE

If the thickness of the panel sheet exceeds 2.5 mm (0.1 in), be sure to use screws with a length of the panel sheet thickness + 4 mm (0.16 in).

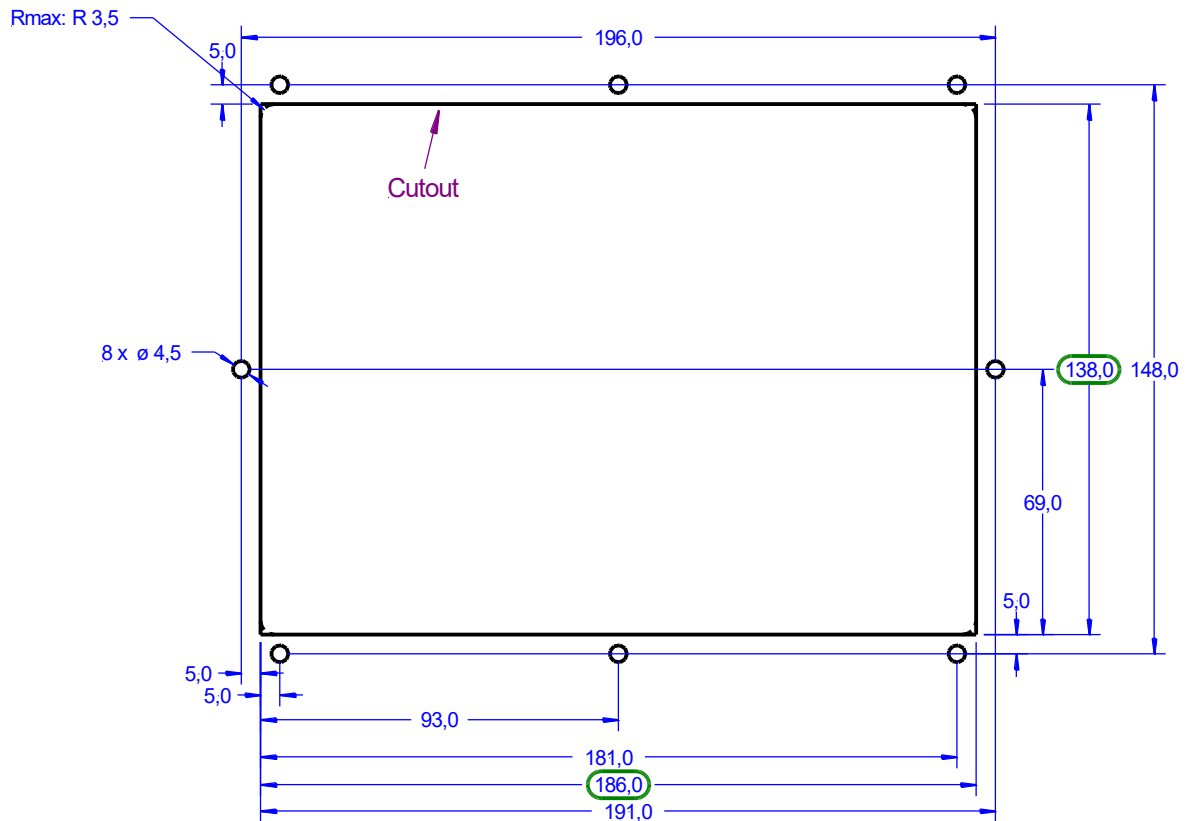

Cutout dimension: 186.0
 186 mm (+1.1 mm) x 138 mm (+1.0 mm) according to DIN 43700/IEC 61554
 7.32 in (+0.045 in) x 5.43 in (+0.04 in)

2006-09-05 | DTSC-200 cutout+drillplan DTSC200ww-3606-ab.SKF

Unit will be mounted with 8 screws (P/N: LR02236) M4 x 6 mm, torque 0.6Nm.

Figure 3-3: Housing - drill plan

Chapter 4. Wiring Diagram

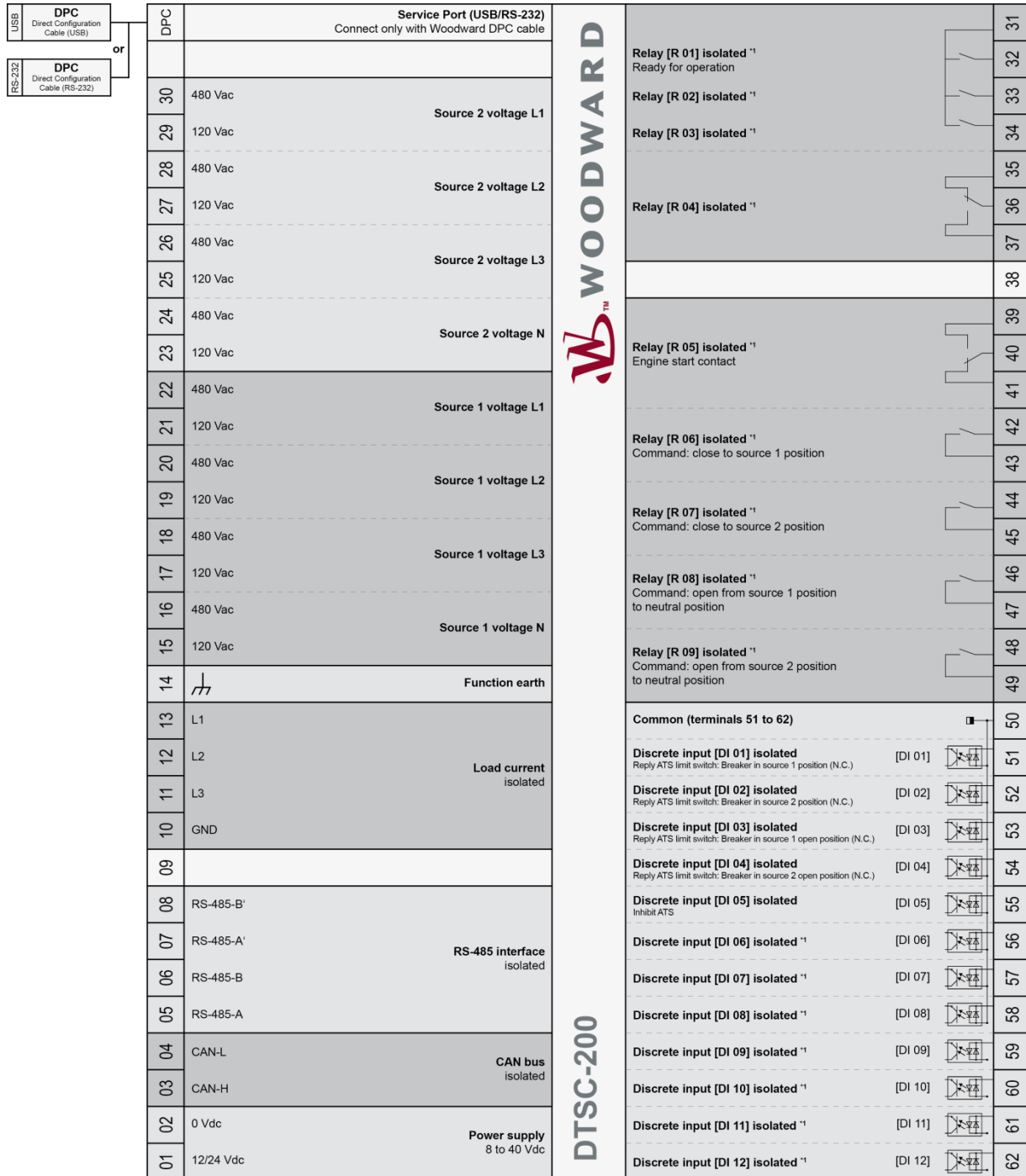

Subject to technical modifications.

¹¹ = configurable via LogicsManager

DTSC-200 Wiring Diagram | Rev. A

Figure 4-1: Wiring diagram

Chapter 5. Connections



WARNING

All technical data and ratings indicated in this chapter are not definite! Only the values indicated in Chapter 6: Technical Data on page 36 are valid!

The following chart may be used to convert square millimeters [mm²] to AWG and vice versa:

AWG	mm ²	AWG	mm ²	AWG	mm ²	AWG	mm ²	AWG	mm ²	AWG	mm ²
30	0.05	21	0.38	14	2.5	4	25	3/0	95	600MCM	300
28	0.08	20	0.5	12	4	2	35	4/0	120	750MCM	400
26	0.14	18	0.75	10	6	1	50	300MCM	150	1000MCM	500
24	0.25	17	1.0	8	10	1/0	55	350MCM	185		
22	0.34	16	1.5	6	16	2/0	70	500MCM	240		

Table 5-1: Conversion chart - wire size

Power Supply

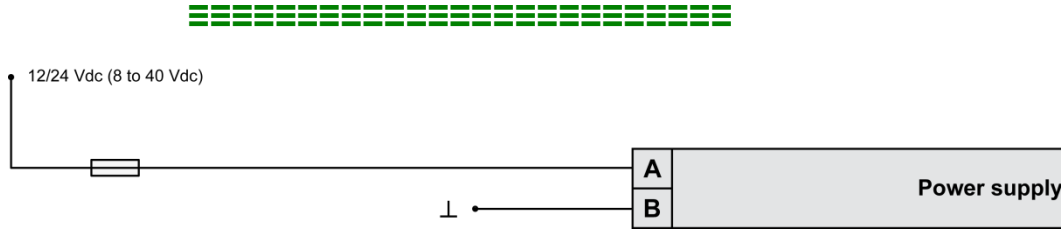

Figure 5-1: Power supply

Figure	Terminal	Description	A _{max}
A	1	12/24Vdc (8 to 40.0 Vdc)	2.5 mm ²
B	2	0 Vdc	2.5 mm ²

Table 5-2: Power supply - terminal assignment

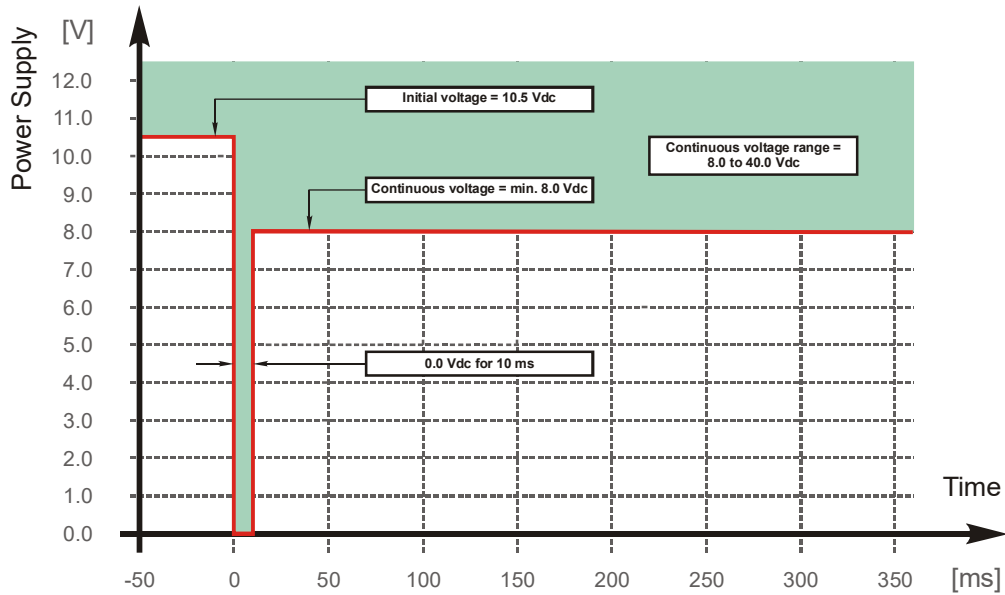

Figure 5-2: Power supply - crank waveform at maximum load



NOTE

Woodward recommends to fuse-protect all lines according to their rated load (rated current). Refer to Appendix A: Recommended Power Supply Units on page 41 for suitable power supply units.

Function Earth

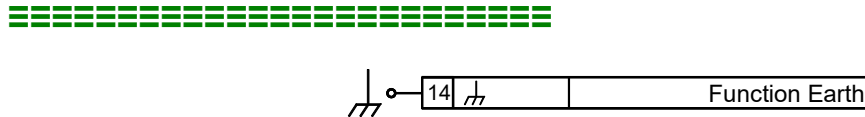

Figure 5-3: Earth ground

Terminal	Description	A _{max}
14	Function earth connection	2.5 mm ²

Table 5-3: Earth ground - terminal assignment



NOTE

Woodward recommends to connect this terminal to ground to comply with the EMC directives.

Voltage Measuring (*FlexRange*)



NOTE

DO NOT use both sets of voltage measuring inputs. The control unit will not measure voltage correctly if the 120 V and 480 V inputs are utilized simultaneously.



NOTE

Woodward recommends protecting the voltage measuring inputs with slow-acting fuses rated for 2 to 6 A.

Voltage Measuring: Source 1

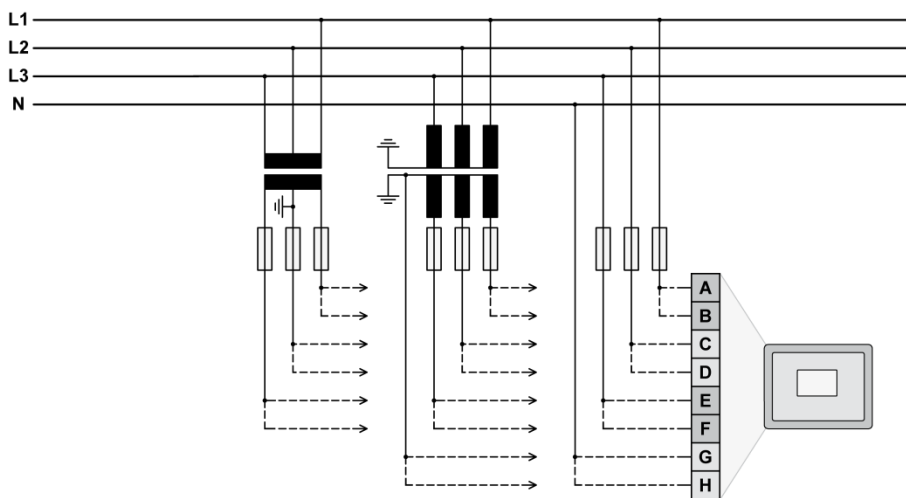

Figure 5-4: Voltage measuring - terminal assignment - source 1 voltage

Figure	Terminal	Description	A _{max}	
A	22	Source 1 Voltage L1	480 Vac	2.5 mm ²
			120 Vac	2.5 mm ²
C	20	Source 1 Voltage L2	480 Vac	2.5 mm ²
			120 Vac	2.5 mm ²
E	18	Source 1 Voltage L3	480 Vac	2.5 mm ²
			120 Vac	2.5 mm ²
G	16	Source 1 Voltage N	480 Vac	2.5 mm ²
			120 Vac	2.5 mm ²

Table 5-4: Voltage measuring - terminal assignment - source 1



NOTE

The 120 V input terminals must be used, if parameter "S1 voltage transf. secondary" (refer to Configuration Manual 37483) is configured with a value between 50 and 130 V for proper measurement.

The 480 V input terminals must be used, if parameter "S1 voltage transf. secondary" (refer to Configuration Manual 37483) is configured with a value between 131 and 480 V for proper measurement.

Voltage Measuring: Source 1, Parameter Setting '3Ph 4W' (3-phase, 4-wire)

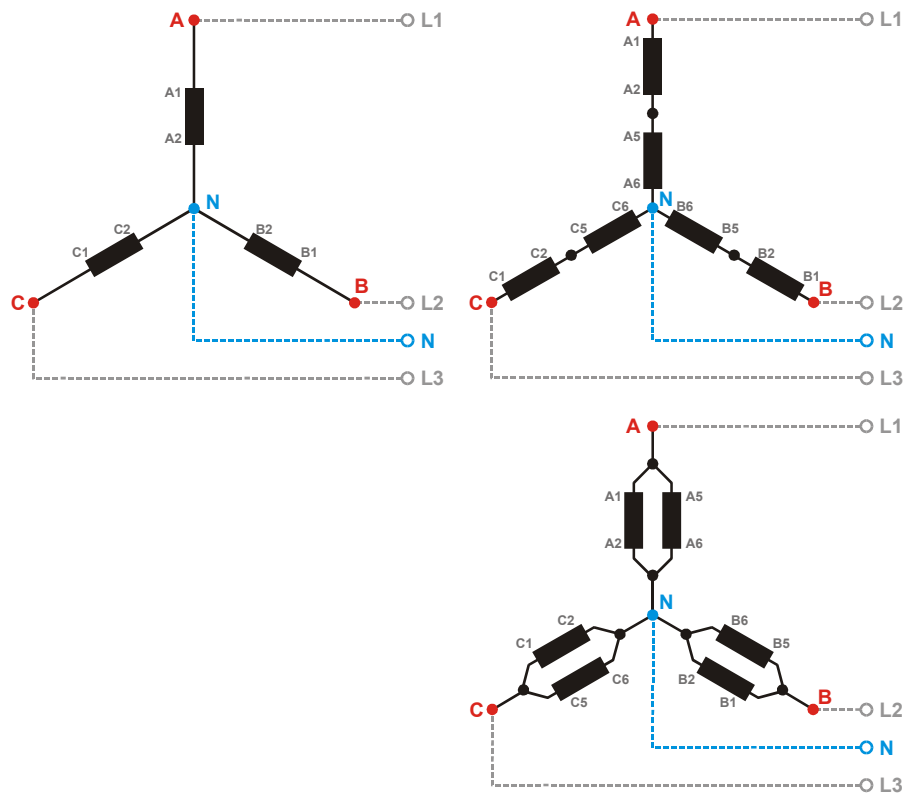

Figure 5-5: Voltage measuring -source 1 PT windings, 3Ph 4W

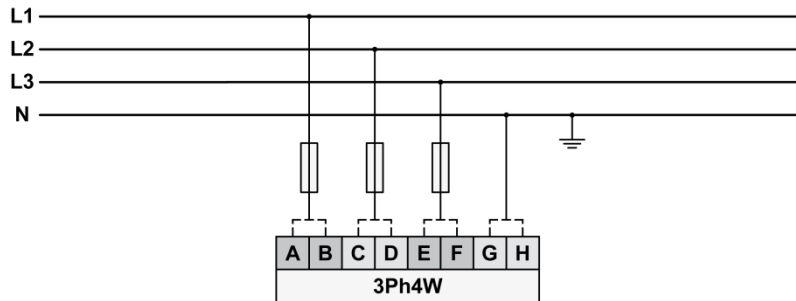

Figure 5-6: Voltage measuring -source 1 measuring inputs, 3Ph 4W

3Ph 4W	Wiring terminals								Note
Rated voltage (range)	[1] 120 V (50 to 130 V _{eff})				[4] 480 V (131 to 480 V _{eff})				1
Measuring range (max.)	[1] 0 to 150 Vac				[4] 0 to 600 Vac				
Figure	A	C	E	G	B	D	F	H	
DTSC-200 terminal	21	19	17	15	22	20	18	16	
Phase	L1	L2	L3	N	L1	L2	L3	N	

Table 5-5: Voltage measuring - terminal assignment - source 1, 3ph 4w

1 For different voltage systems, different wiring terminals have to be used.

Voltage Measuring: Source 1, Parameter Setting '3Ph 3W' (3-phase, 3-wire)

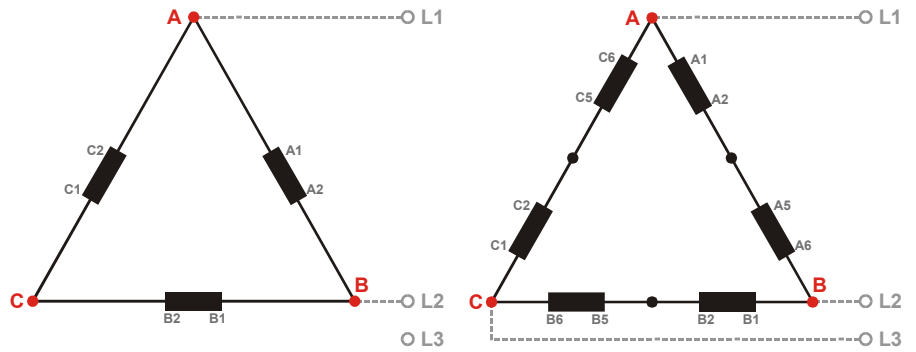

Figure 5-7: Voltage measuring - source 1 PT windings, 3Ph 3W

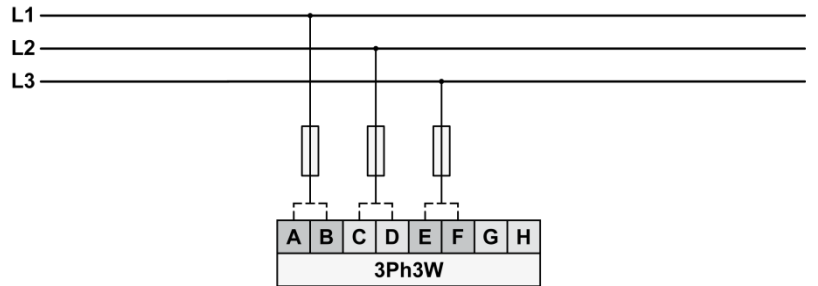

Figure 5-8: Voltage measuring -source 1 measuring inputs, 3Ph 3W

3Ph 3W	Wiring terminals								Note
Rated voltage (range)	[1] 120 V (50 to 130 V _{eff.})				[4] 480 V (131 to 480 V _{eff.})				2
Measuring range (max.)	[1] 0 to 150 Vac				[4] 0 to 600 Vac				
Figure	A	C	E	G	B	D	F	H	
DTSC-200 terminal	21	19	17	15	22	20	18	16	
Phase	L1	L2	L3	---	L1	L2	L3	---	

Table 5-6: Voltage measuring - terminal assignment - source 1, 3Ph 3W



NOTE

If any line input (L1, L2 or L3) is connected to PE or N, the line reactive power (VL1-I1, VL2-I2, and VL3-I3) will not be correctly calculated which results in inaccurate overall reactive power and apparent power calculations. However, single current and overall active (real) power calculations are correct.

2 For different voltage systems, different wiring terminals have to be used.

Voltage Measuring: Source 1, Parameter Setting '1Ph 3W' (1-phase, 3-wire)

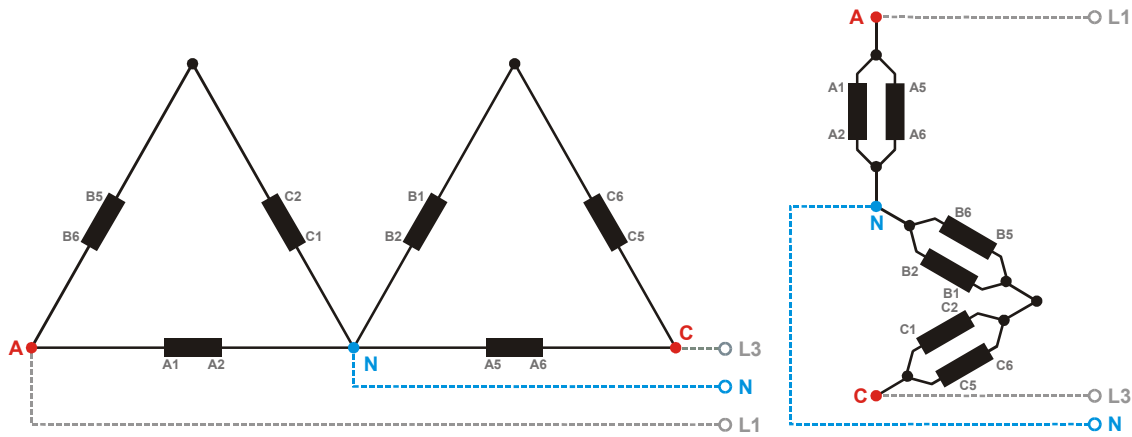

Figure 5-9: Voltage measuring - source 1 PT windings, 1Ph 3W

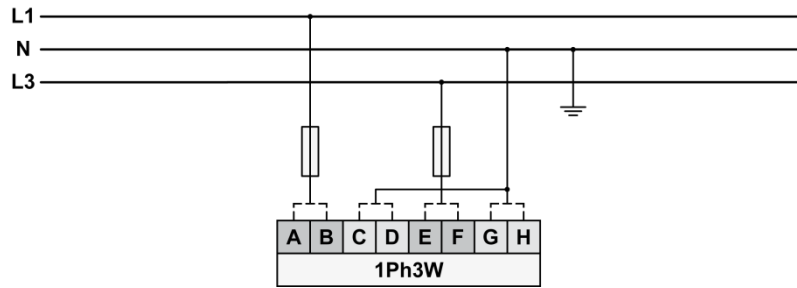

Figure 5-10: Voltage measuring -source 1 measuring inputs, 1Ph 3W

1Ph 3W	Wiring terminals								Note
Rated voltage (range)	[1] 120 V (50 to 130 V _{eff.})				[4] 480 V (131 to 480 V _{eff.})				3
Measuring range (max.)	[1] 0 to 150 Vac				[4] 0 to 600 Vac				
Figure	A	C	E	G	B	D	F	H	
DTSC-200 terminal	21	19	17	15	22	20	18	16	
Phase	L1	N	L3	N	L1	N	L3	N	

Table 5-7: Voltage measuring - terminal assignment - source 1, 1Ph 3W

3 For different voltage systems, different wiring terminals have to be used.

Voltage Measuring: Source 1, Parameter Setting '1Ph 2W' (1-phase, 2-wire)

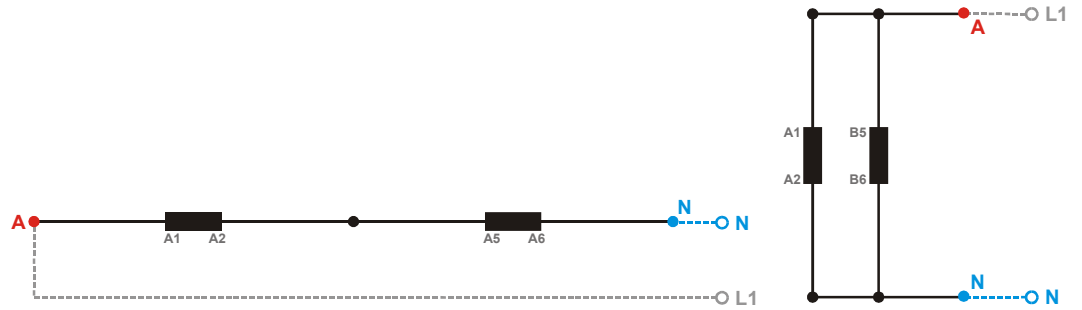

Figure 5-11: Voltage measuring - source 1 PT windings, 1Ph 2W

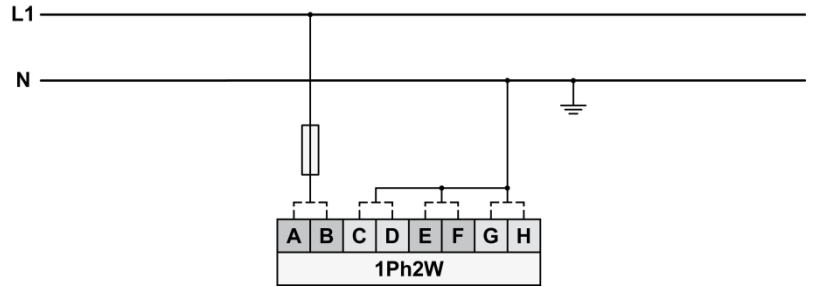

Figure 5-12: Voltage measuring -source 1 measuring inputs, 1Ph 2W

1Ph 2W	Wiring terminals								Note
Rated voltage (range)	[1] 120 V (50 to 130 V _{eff.})				[4] 480 V (131 to 480 V _{eff.})				4
Measuring range (max.)	[1] 0 to 150 Vac				[4] 0 to 600 Vac				
Figure	A	C	E	G	B	D	F	H	
DTSC-200 terminal	21	19	17	15	22	20	18	16	
Phase	L1	N	N	N	L1	N	N	N	

Table 5-8: Voltage measuring - terminal assignment - source 1, 1Ph 2W

4 For different voltage systems, different wiring terminals have to be used.

Voltage Measuring: Source 2

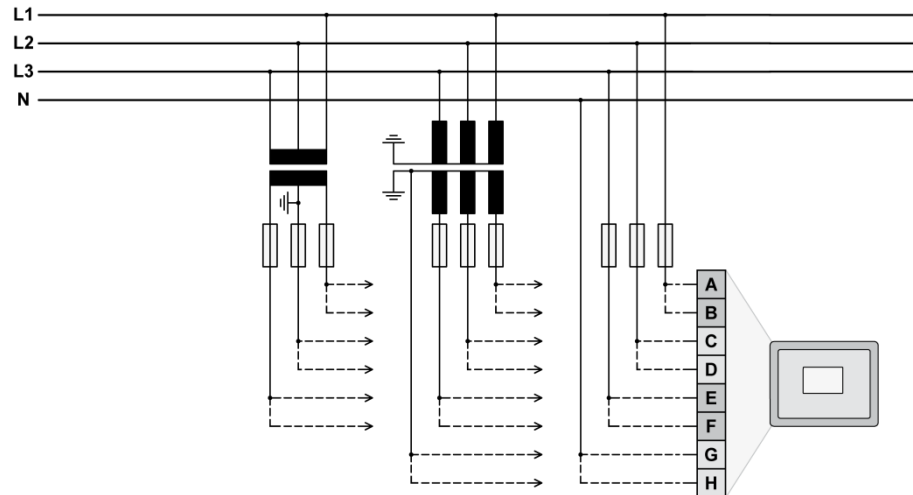

Figure 5-13: Voltage measuring - source 2

Figure	Terminal	Description		A_{max}
A	30	Source 2 Voltage L1	480 Vac	2.5 mm ²
B	29		120 Vac	2.5 mm ²
C	28	Source 2 Voltage L2	480 Vac	2.5 mm ²
D	27		120 Vac	2.5 mm ²
E	26	Source 2 Voltage L3	480 Vac	2.5 mm ²
F	25		120 Vac	2.5 mm ²
G	24	Source 2 Voltage N	480 Vac	2.5 mm ²
H	23		120 Vac	2.5 mm ²

Table 5-9: Voltage measuring - terminal assignment - source 2 voltage



NOTE

The 120 V input terminals must be used, if parameter "S2 voltage transf. secondary" (refer to Configuration Manual 37483) is configured with a value between 50 and 130 V for proper measurement.

The 480 V input terminals must be used, if parameter "S2 voltage transf. secondary" (refer to Configuration Manual 37483) is configured with a value between 131 and 480 V for proper measurement.

Voltage Measuring: Source 2, Parameter Setting '3Ph 4W' (3-phase, 4-wire)

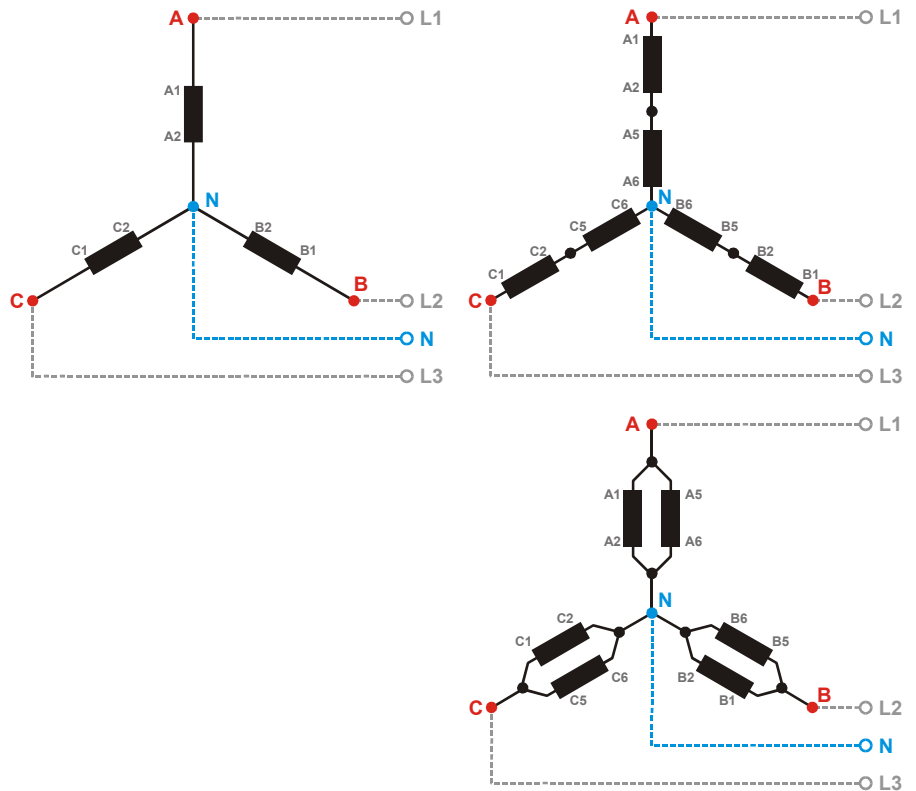

Figure 5-14: Voltage measuring - source 2 PT windings, 3Ph 4W

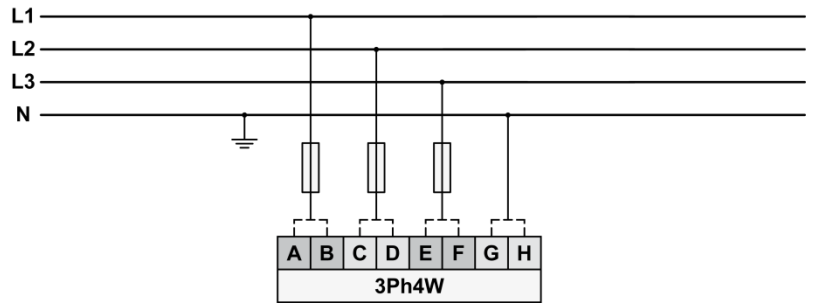

Figure 5-15: Voltage measuring -source 2 measuring inputs, 3Ph 4W

3Ph 4W	Wiring terminals								Note
Rated voltage (range)	[1] 120 V (50 to 130 V _{eff.})				[4] 480 V (131 to 480 V _{eff.})				5
Measuring range (max.)	[1] 0 to 150 Vac				[4] 0 to 600 Vac				
Figure	A	C	E	G	B	D	F	H	
DTSC-200 terminal	29	27	25	23	30	28	26	24	
Phase	L1	L2	L3	N	L1	L2	L3	N	

Table 5-10: Voltage measuring - terminal assignment - source 2, 3Ph 4W

5 For different voltage systems, different wiring terminals have to be used.

Voltage Measuring: Source 2, Parameter Setting '3Ph 3W' (3-phase, 3-wire)

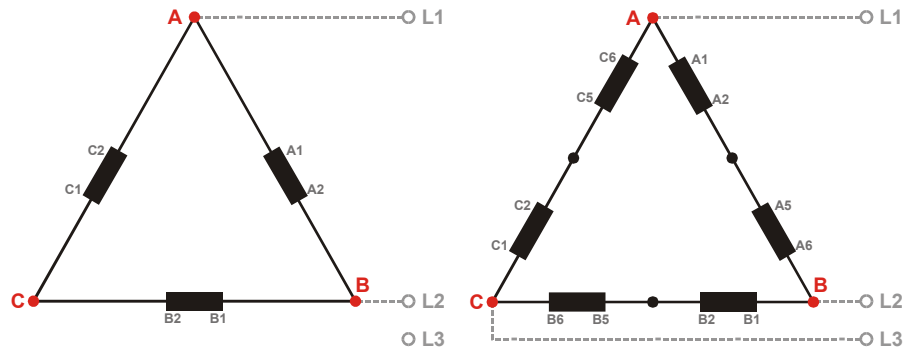

Figure 5-16: Voltage measuring - source 2 PT windings, 3Ph 3W

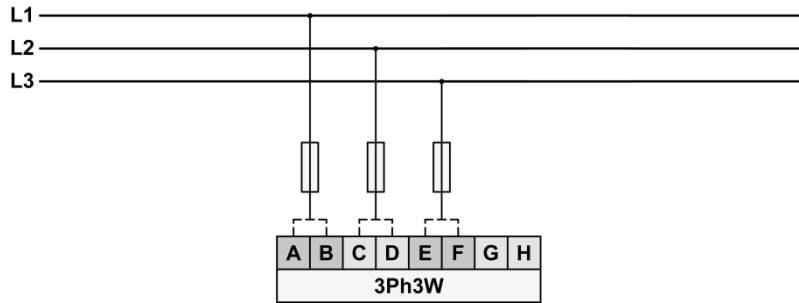

Figure 5-17: Voltage measuring -source 2 measuring inputs, 3Ph 3W

3Ph 3W	Wiring terminals								Note
	Rated voltage (range)	[1] 120 V (50 to 130 V _{eff.})				[4] 480 V (131 to 480 V _{eff.})			
Measuring range (max.)	[1] 0 to 150 Vac				[4] 0 to 600 Vac				
Figure	A	C	E	G	B	D	F	H	
DTSC-200 terminal	29	27	25	23	30	28	26	24	
Phase	L1	L2	L3	---	L1	L2	L3	---	

Table 5-11: Voltage measuring - terminal assignment - source 2, 3Ph 3W

6 For different voltage systems, different wiring terminals have to be used.

Voltage Measuring: Source 2, Parameter Setting '1Ph 3W' (1-phase, 3-wire)

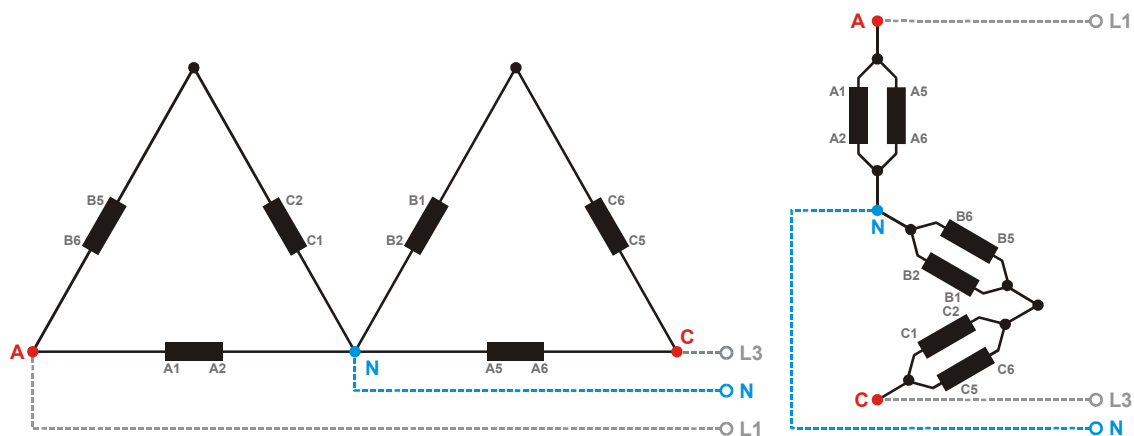

Figure 5-18: Voltage measuring - source 2 PT windings, 1Ph 3W

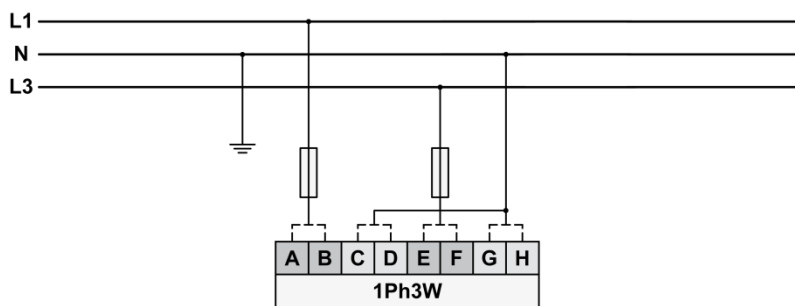

Figure 5-19: Voltage measuring -source 2 measuring inputs, 1Ph 3W

1Ph 3W	Wiring terminals								Note
	Rated voltage (range)	[1] 120 V (50 to 130 V _{eff.})				[4] 480 V (131 to 480 V _{eff.})			
Measuring range (max.)	[1] 0 to 150 Vac								
Figure	A	C	E	G	B	D	F	H	
DTSC-200 terminal	29	27	25	23	30	28	26	24	
Phase	L1	N	L3	N	L1	N	L3	N	

Table 5-12: Voltage measuring - terminal assignment - source 2, 1Ph 3W

7 For different voltage systems, different wiring terminals have to be used.

Voltage Measuring: Source 2, Parameter Setting '1Ph 2W' (1-phase, 2-wire)

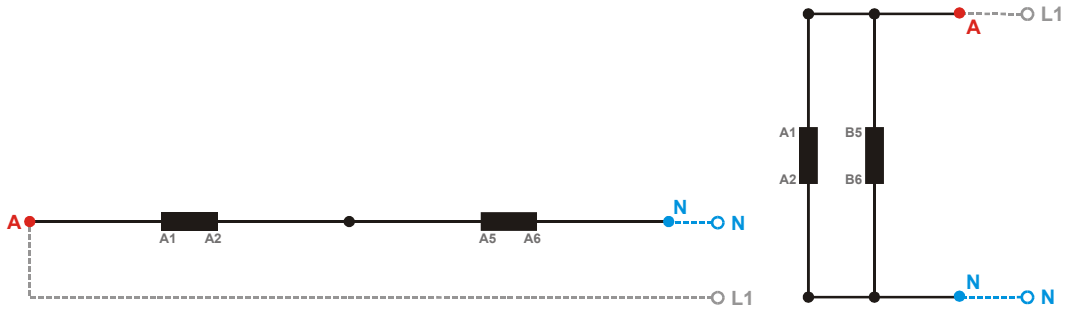

Figure 5-20: Voltage measuring - source 2 PT windings, 1Ph 2W

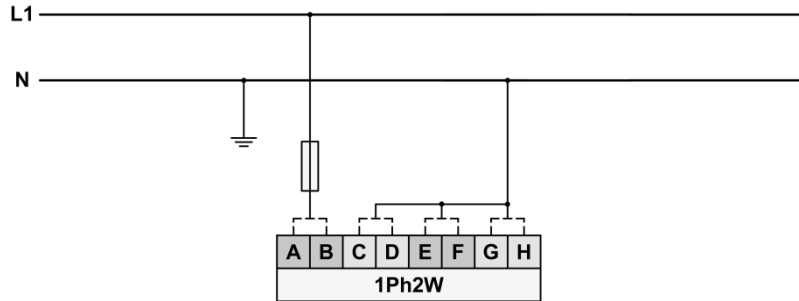

Figure 5-21: Voltage measuring -source 2 measuring inputs, 1Ph 2W

1Ph 2W		Wiring terminals								Note
Rated voltage (range)	[1] 120 V (50 to 130 V _{eff.})					[4] 480 V (131 to 480 V _{eff.})				8
Measuring range (max.)	[1] 0 to 150 Vac					[4] 0 to 600 Vac				
Figure	A	C	E	G	B	D	F	H		
DTSC-200 terminal	29	27	25	23	30	28	26	24		
Phase	L1	N	N	N	L1	N	N	N		

Table 5-13: Voltage measuring - terminal assignment - source 2, 1Ph 2W

8 For different voltage systems, different wiring terminals have to be used.

Current Measuring



CAUTION

Before disconnecting the current transformer/CT secondary connections or the connections of the current transformer/CT at the device, ensure that the current transformer/CT is short-circuited.

Load



NOTE

Please connect the wires of the current transformer "L (x)" as near as possible to the unit.



NOTE

Generally, one line of the current transformers secondary is to be grounded.

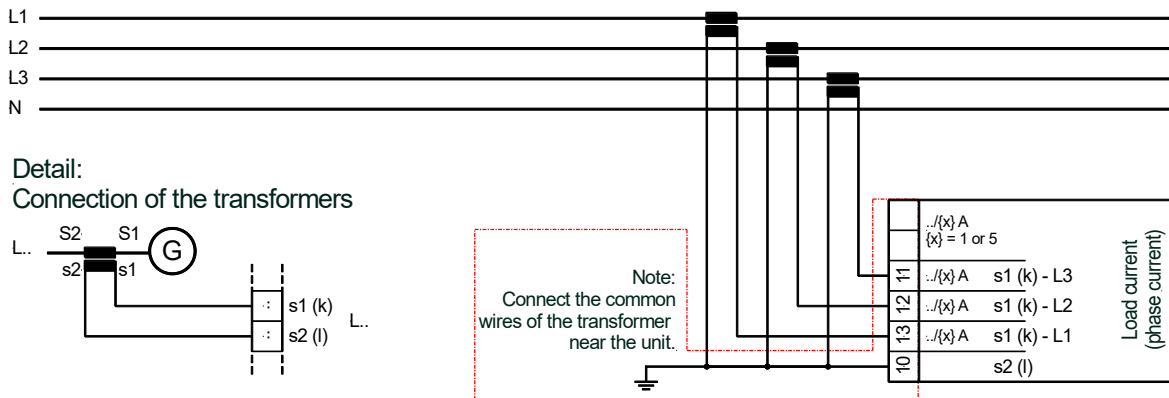

Figure 5-22: Current measuring - load

Terminal	Description	A _{max}
10	Load current - phases L1/L2/L3 - transformer terminals x2 (l)	2.5 mm ²
11	Load current - phase L3 - transformer terminal s1 (k)	2.5 mm ²
12	Load current - phase L2 - transformer terminal s1 (k)	2.5 mm ²
13	Load current - phase L1 - transformer terminal s1 (k)	2.5 mm ²

Table 5-14: Current measuring - terminal assignment - load current

Current Measuring: Load, parameter setting 'L1 L2 L3'

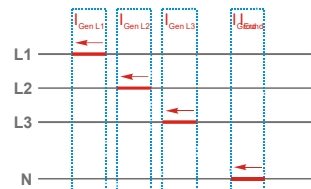

Figure 5-23: Current measuring - load, L1 L2 L3

L1 L2 L3	Wiring terminals				Notes
DTSC-200	13	12	11	10	
Phase	L1	L2	L3	GND	

Table 5-15: Current measuring - terminal assignment - load, L1 L2 L3

Current Measuring: Load, parameter setting 'Phase L1', 'Phase L2' & 'Phase L3'

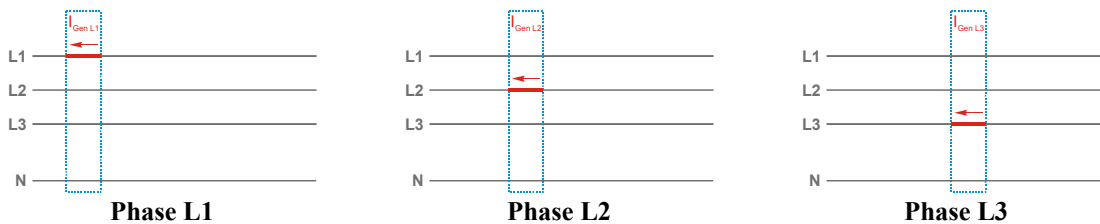

Figure 5-24: Current measuring - load, Phase Lx

		Wiring terminals				Notes
Phase L1						
DTSC-200		13	12	11	10	
Phase		L1	---	---	GND	
Phase L2						
DTSC-200		13	12	11	10	
Phase		---	L2	---	GND	
Phase L3						
DTSC-200		13	12	11	10	
Phase		---	---	L3	GND	

Table 5-16: Current measuring - terminal assignment - load, Phase Lx

Discrete Inputs



Discrete Inputs: Bipolar Signals

The discrete inputs are electrically isolated allowing for a bipolar connection. The discrete inputs are able to handle positive or negative signals.



NOTE

All discrete inputs must use the same polarity, either positive or negative signals, due to the common ground.

Discrete Inputs: Positive / Negative Signal

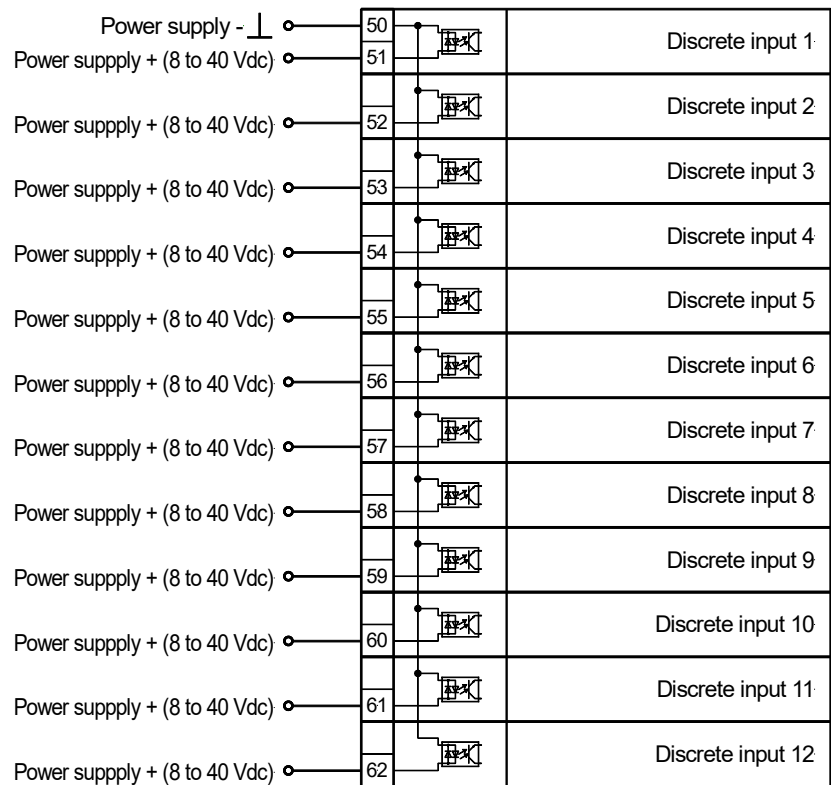

Figure 5-25: Discrete inputs - alarm/control input - positive signal

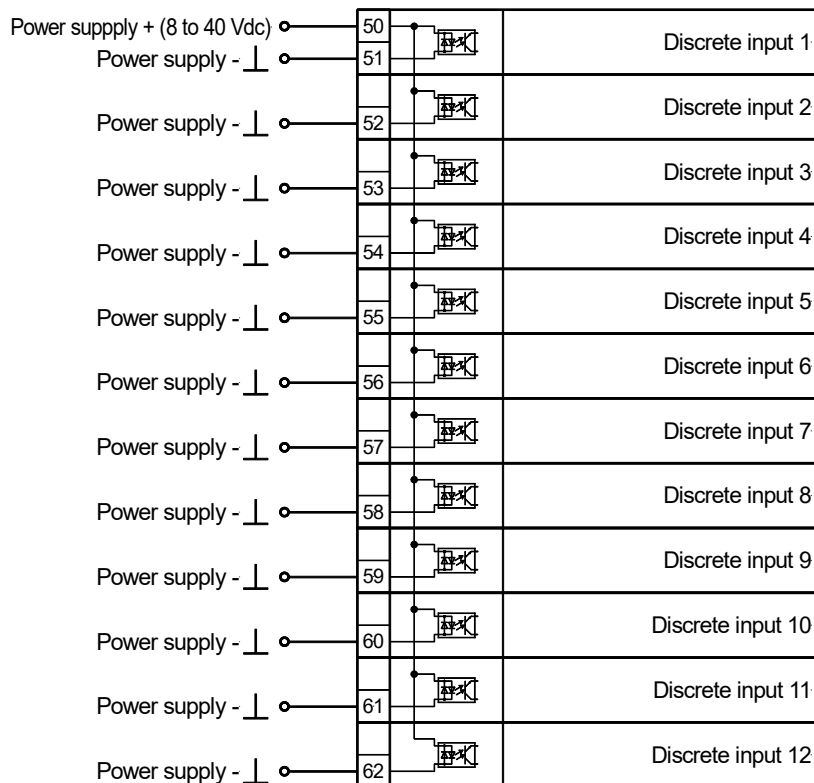

Figure 5-26: Discrete inputs - alarm/control input - negative signal

Terminal		Description	Type ↓	A _{max}
Com.	Signal			
50	51	Discrete input [DI 01] [S1] Reply from ATS limit switch: Breaker in source 1 position	NC	2.5 mm ²
	52	Discrete input [DI 02] [S2] Reply from ATS limit switch: Breaker in source 2 position	NC	2.5 mm ²
	53	Discrete input [DI 03] [S1O] Reply from ATS limit switch: Breaker in source 1 open position	NC	2.5 mm ²
	54	Discrete input [DI 04] [S2O] Reply from ATS limit switch: Breaker in source 2 open position	NC	2.5 mm ²
	55	Discrete input [DI 05] Inhibit ATS	SW (NC)	2.5 mm ²
	56	Discrete input [DI 06] Alarm input (programmable)	SW	2.5 mm ²
	57	Discrete input [DI 07] Alarm input (programmable)	SW	2.5 mm ²
	58	Discrete input [DI 08] Alarm input (programmable)	SW	2.5 mm ²
	59	Discrete input [DI 09] Alarm input (programmable)	SW	2.5 mm ²
	60	Discrete input [DI 10] Alarm input (programmable)	SW	2.5 mm ²
	61	Discrete input [DI 11] Alarm input (programmable)	SW	2.5 mm ²
	62	Discrete input [DI 12] Alarm input (programmable)	SW	2.5 mm ²

SW-switchable via the software, [NO]-type 1 (N.O./make contact), [NC] -type 2 (N.C./break contact)

Table 5-17: Discrete input - terminal assignment - alarm/control inputs

NOTE
 The discrete inputs for the breaker position reply messages (DIs 1 through 4) are fixed to N.C. and are evaluated as N.C., i.e. the breaker is considered as "in position" if the respective DI is de-energized.

Discrete Inputs: Operation Logic

Discrete inputs (5 to 12) may be configured to normally open (N.O.) or normally closed (N.C.) states. In the state N.O., no potential is present during normal operation; if a control operation is performed, the input is energized. In the state N.C., a potential is continuously present during normal operation; if a control operation is performed, the input is de-energized.

The N.O. or N.C. contacts may be connected to the signal terminal as well as to the ground terminal of the discrete input. See previous chapter Discrete Inputs: Bipolar Signals on page 27 for details.

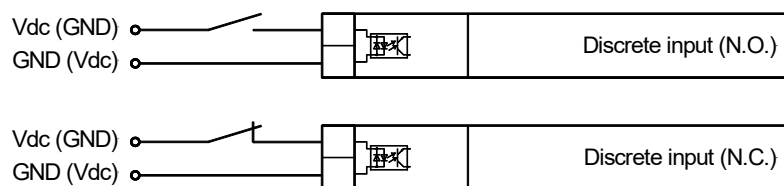

Figure 5-27: Discrete inputs - alarm/control inputs - operation logic

Discrete Outputs (Control Outputs And *LogicsManager*)

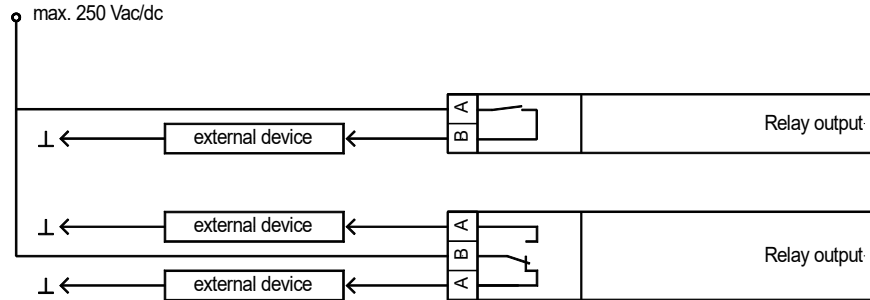

Figure 5-28: Discrete outputs

Terminal		Description	A _{max}	
Term.	Com.			
A	B	Form A, common contact	Type ↓	
32	31	Discrete output [R 01]	<i>LogicsManager</i>	SW 2.5 mm ²
33		Discrete output [R 02]	<i>LogicsManager</i>	SW 2.5 mm ²
34		Discrete output [R 03]	<i>LogicsManager</i>	SW 2.5 mm ²
A	B	Form C, separate contacts	Type ↓	
35	36	Discrete output [R 04]	<i>LogicsManager</i>	NC 2.5 mm ²
37		Discrete output [R 04]		NO 2.5 mm ²
39	40	Discrete output [R 05]	Engine start	NO 2.5 mm ²
41		Discrete output [R 05]		NC 2.5 mm ²
A	B	Form A, separate contacts	Type ↓	
43	42	Discrete output [R 06]	[C1] Command: close to source 1 position	NO 2.5 mm ²
45	44	Discrete output [R 07]	[C2] Command: close to source 2 position	NO 2.5 mm ²
47	46	Discrete output [R 08]	[C10] Command: open from source 1 to neutral position	NO 2.5 mm ²
49	48	Discrete output [R 9]	[C20] Command: open from source 2 to neutral position	NO 2.5 mm ²

LogicsManager..using the function *LogicsManager* it is possible to freely program the relays SW-switchable via the software, [NO]-type 1 (N.O./make contact), [NC]-type 1 (N.C./break contact)

Table 5-18: Discrete outputs - terminal assignment

Interfaces



RS-485 Modbus RTU Slave

	5	6	7	8
Interface	RS-485-A	RS-485-B	RS-485-A'	RS-485-B'
	RS-485 Modbus RTU Slave (isolated, full duplex)			

Figure 5-29: Interface

Terminal				Description
5	6	7	8	
RS-485-A (TxD-)	RS-485-B (TxD+)	RS-485-A' (RxD-)	RS-485-B' (RxD+)	RS-485, Modbus RTU Slave

Table 5-19: RS-485 Modbus interface - terminal assignment

Half-Duplex with Modbus on RS-485

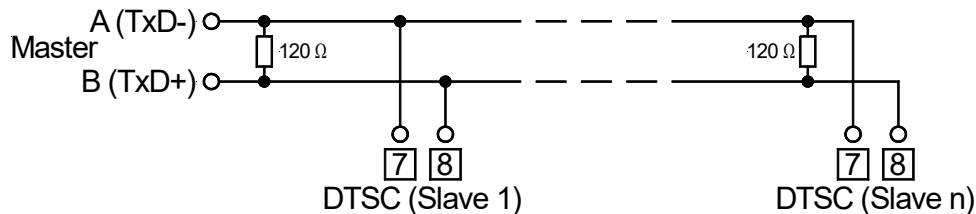

Figure 5-30: RS-485 Modbus - connection for half-duplex operation

Full-Duplex with Modbus on RS-485

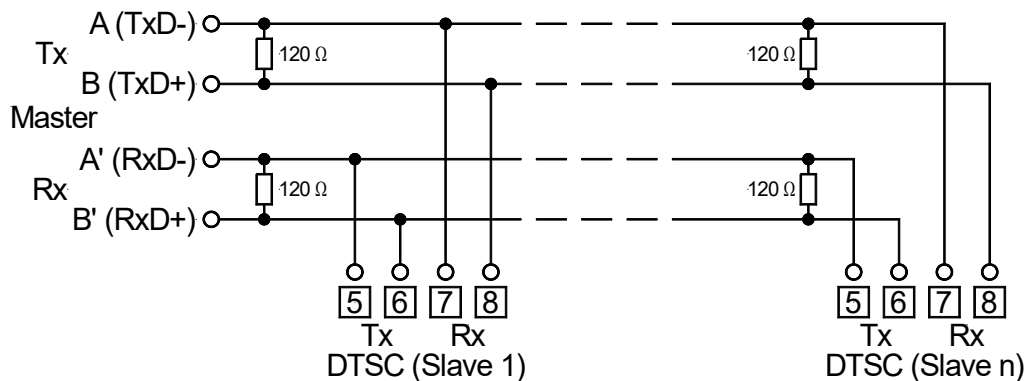

Figure 5-31: RS-485 Modbus - connection for full-duplex operation



NOTE

Please note that the DTSC must be configured for half- or full-duplex configuration (refer to parameter 3173 in the Configuration Manual 37483).

Service Port

The Woodward specific service port is a connector (RJ-45) to extend the interfaces of the controller.

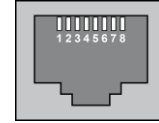

Figure 5-32: Service port connector (RJ-45)

NOTE
The service port can be only used in combination with an optional Woodward direct configuration cable (DPC).

Direct configuration cable (DPC)

The DPC cable is used to configure the device with the ToolKit configuration software and external extensions/applications.

There are two versions available:

- DPC-USB direct configuration cable
- DPC-RS-232 direct configuration cable

DPC-USB direct configuration cable

Use the DPC-USB direct configuration cable if you want to connect the Woodward controller to an external device (master) which is equipped with an USB port.

Order item number:

DPC-USB direct configuration cable – P/N 5417-1251

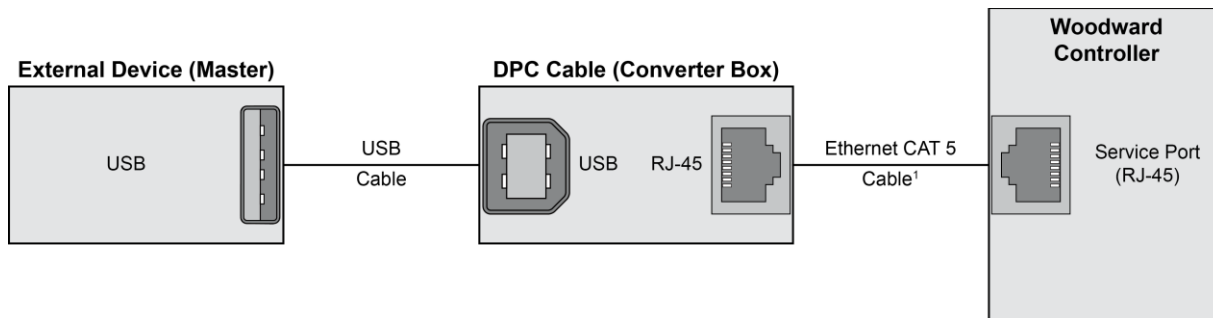

Figure 5-33: DPC-USB wiring - schematic

NOTE
¹ Use the Ethernet CAT 5 cable which is supplied with the DPC-USB converter. The maximum cable length must not exceed 0.5 m.

DPC-RS-232 direct configuration cable

Use the DPC-RS-232 direct configuration cable if you want to connect the Woodward controller to an external device (master) which is equipped with an RS-232 port.

Order item number:

DPC-RS-232 direct configuration cable – P/N 5417-557

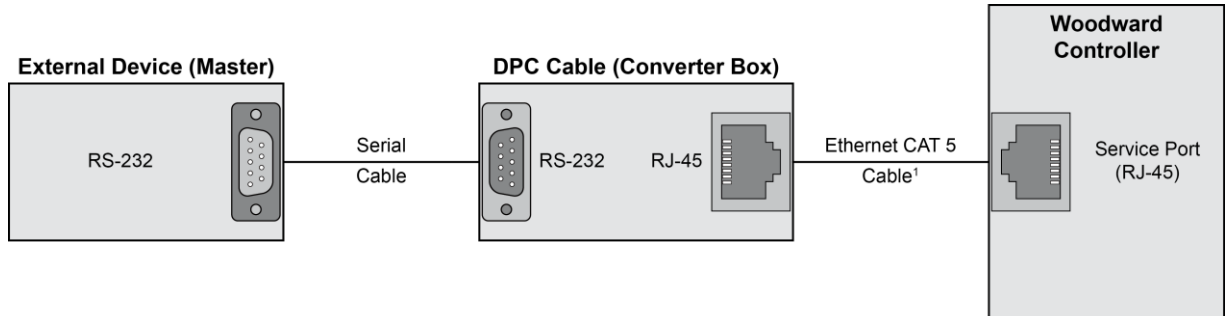

Figure 5-34: DPC-RS-232 wiring - schematic

**NOTE**

¹ Use the Ethernet CAT 5 cable which is supplied with the DPC-USB converter. The maximum cable length must not exceed 0.5 m.

**NOTE**

For a continuous operation with the direct configuration cable DPC-RS-232 (e.g. remote control of controller), it is required to use at least revision F (P/N 5417-557 Rev. F) of the DPC-RS-232. When using a DPC-RS-232 of an earlier revision, problems may occur in continuous operation. The shield connector (6.3 mm tab connector) at the DPC-RS-232 of revision F (P/N 5417-557 Rev. F) and above must be connected to ground.

CAN Bus Interfaces (*FlexCAN*)

Wiring

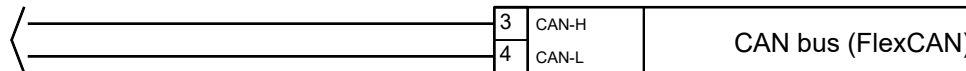

Figure 5-35: Interfaces - CAN bus (*FlexCAN*)

Terminal	Description		A _{max}
3	CAN bus (<i>FlexCAN</i>)	CAN-H	2.5 mm ²
4		CAN-L	2.5 mm ²

Table 5-20: CAN bus interface - terminal assignment

Shielding

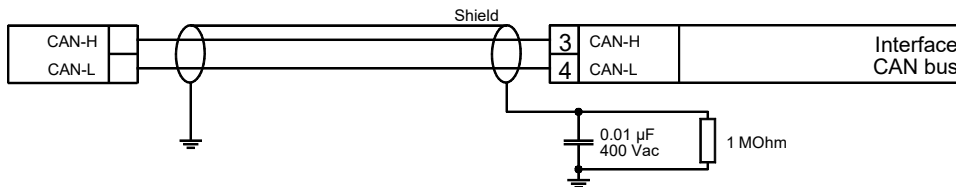

Figure 5-36: Interfaces - CAN bus - wiring of shielding



NOTE

Please note that the CAN bus must be terminated with a resistor, which corresponds to the impedance of the cable (e.g. 120 Ohms, 1/4 W) at both ends. The termination resistor is connected between CAN-H and CAN-L.

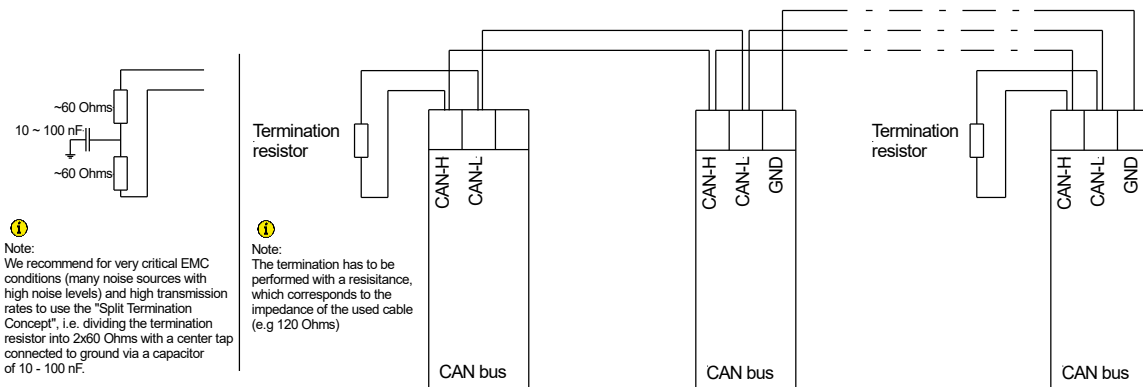

Figure 5-37: Interfaces - CAN bus - termination

Possible CAN Bus Problems

If no data is transmitted on the CAN bus, check the following for common CAN bus communication problems:

- T structure bus is utilized
- CAN-L and CAN-H are switched
- Not all devices on the bus are using identical Baud rates
- Termination resistor(s) are missing
- The configured baud rate is too high for wiring length
- The CAN bus cable is co-routed with power cables

Woodward recommends the use of twisted-pair cables for the CAN bus (i.e.: Lappkabel Unitronic LIYCY (TP) 2×2×0.25, UNITRONIC-Bus LD 2×2×0.22).

Maximum CAN bus Length

The maximum length of the communication bus wiring is dependent on the configured Baud rate. Refer to Table 5-21 for the maximum bus length (Source: CANopen; Holger Zeltwanger (Hrsg.); 2001 VDE VERLAG GMBH, Berlin und Offenbach; ISBN 3-8007-2448-0).

Baud rate	Max. length
1000 kbit/s	25 m
800 kbit/s	50 m
500 kbit/s	100 m
250 kbit/s	250 m
125 kbit/s	500 m
50 kbit/s	1000 m
20 kbit/s	2500 m

Table 5-21: Maximum CAN bus length

The maximum specified length for the communication bus wiring might not be achieved if poor quality wire is utilized, there is high contact resistance, or other conditions exist. Reducing the baud rate may overcome these issues.

Chapter 6. Technical Data

Nameplate -----

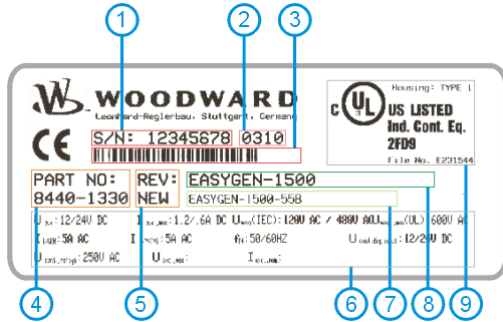

1	S/N	Serial number (numerical)
2	S/N	Date of production (YYMM)
3	S/N	Serial number (Barcode)
4	P/N	Item number
5	REV	Item revision number
6	Details	Technical data
7	Type	Description (short)
8	Type	Description (long)
9	UL	UL sign

Measuring values, voltages ----- Δ/Δ

- Measuring voltages

120 V

Rated value (V_{rated})	69/120 Vac
Maximum value (V_{max})	max. 86/150 Vac
Rated voltage phase – ground	150 Vac
Rated surge voltage	2.5 kV

480 V

Rated value (V_{rated})	277/480 Vac
Maximum value (V_{max})	max. 346/600 Vac
Rated voltage phase – ground	300 Vac
Rated surge voltage	4.0 kV

- Linear measuring range $1.25 \times V_{rated}$
- Measuring frequency 50/60 Hz (40.0 to 70.0 Hz)
- Accuracy Class 1
- Input resistance per path

120 V	0.498 M Ω
480 V	2.0 M Ω
- Maximum power consumption per path < 0.15 W

Measuring values, currents ----- isolated

- Measuring current

[1] Rated value (I_{rated})	.. /1 A
[5] Rated value (I_{rated})	.. /5 A

- Accuracy Class 1
- Linear measuring range Load (terminals 10 through 13) $3.0 \times I_{rated}$
- Maximum power consumption per path < 0.15 VA
- Rated short-time current (1 s)

[1]	$50.0 \times I_{rated}$
[5]	$10.0 \times I_{rated}$

Ambient variables -----

- Power supply 12/24 Vdc (8 to 40 Vdc; not buffered)
Battery ground (terminal 2) must be grounded to the chassis
- Inrush current max. 50 A peak, 1 ms
- Input capacitance 2000 μ F
- Intrinsic consumption max. 8 W
in power save mode (backlight, relays off) 3 W
- Degree of pollution 2

Discrete inputs	isolated
- Input range ($V_{Cont, digital\ input}$)	Rated voltage 12/24 Vdc (8 to 40 Vdc)
- Input resistance	approx. 20 k Ω
Discrete outputs Group A [R 1-4]	isolated
- Contact material.....	AgCdO
- General purpose (GP) ($V_{Cont, relay\ output}$)	
AC	2.00 Aac@250 Vac
DC	2.00 Adc@24 Vdc
	0.36 Adc@125 Vdc
	0.18 Adc@250 Vdc
- Pilot Duty (PD) ($V_{Cont, relay\ output}$)	
DC	1.00 Adc@24 Vdc
	0.22 Adc@125 Vdc
	0.10 Adc@250 Vdc
- B300	
Discrete outputs Engine Start [R 5]	isolated
- Contact material.....	AgNi 90/10
- General purpose (GP) ($V_{Cont, relay\ output}$)	
AC	10.00 Aac@250 Vac
Discrete outputs Group B [R 6-9]	isolated
- Contact material.....	AgNi 90/10
- General purpose (GP) ($V_{Cont, relay\ output}$)	
AC	10.00 Aac@250 Vac
Interface	
Service Port	galvanically not isolated
- Proprietary interface	connect only with Woodward DPC cable
RS-485 interface	isolated
- Insulation voltage	500 Vac
- Version	RS-485
- Signal level	5V
CAN bus interface	isolated
- Insulation voltage	500 Vac
- Version	CAN bus
- Internal line termination	Not available
Battery	
- Type.....	Lithium
- Durability (at operation without power supply).....	approx. 5 years
- Battery field replacement.....	not possible

- Housing** -----
- Type easYpack
 - Dimensions (W × H × D) 219 × 171 × 61 mm (8.6 × 6.7 × 2.4 in)
 - Front cutout (W × H) 186 [+1.1] × 138 [+1.0] mm
 - Material glass fiber-reinforced plastic
 - Wiring screw-plug-terminals 14 AWG / 2.5 mm²
 - Recommended tightening torque 5 to 7 pound-force inches / 0.5 to 0.8 Nm
use 60/75 °C copper wire 14 AWG / 2.5 mm² only
use class 1 wire only or equivalent
 - Weight approx. 800 g (1.75 lb)
- Protection** -----
- Protection system IP54 from front with clamp kit
IP65 from front with screw kit
IP20 from back
 - Front folio insulating surface
 - EMC test (CE) tested according to applicable EN guidelines
 - Listings CE marking; UL listing for ordinary locations
 - Type approval UL/cUL listed, Ordinary Locations, File No.: 231544

Chapter 7.

Environmental Data

Dynamics -----	
- Frequency Range – Sine Sweep	5Hz to 150Hz
- Acceleration	4G
- Frequency Range - Random	10Hz to 500Hz
- Power Density	0,015G ² /Hz
- RMS Value.....	1,04 Grms
- Standards	
	EN 60255-21-1 (EN 60068-2-6, Fc)
	EN 60255-21-3
	Lloyd's Register, Vibration Test2
	SAEJ1455 Chassis Data
	MIL-STD 810F, M514.5A, Cat.4,
	Truck/Trailer tracked-restrained
	cargo, Fig. 514.5-C1
Shock -----	
-	40G, Sawtooth Pulse, 11ms
- Standards	
	EN 60255-21-2
	MIL-STD 810F, M516.5, Procedure 1
Temperature -----	
- Cold, Dry Heat (storage)	-30°C (-22°F) / 80°C (176°F)
- Cold, Dry Heat (operating)	-20°C (-4°F) / 60 °C (140°F)
- Standards	
	IEC 60068-2-2, Test Bb and Bd
	IEC 60068-2-1, Test Ab and Ad
Humidity -----	
-	60°C, 95% RH, 5 days
- Standards	
	IEC 60068-2-30, Test Db
Altitude -----	
- Maximum operating altitude.....	2000 m (6,500 ft)

Chapter 8. Accuracy

Measuring value		Display	Accuracy	Notes
Frequency				
Source 1	$f_{L1N}, f_{L2N}, f_{L3N}$	15.0 to 85.0 Hz	0.1 %	-
Source 2	$f_{L1N}, f_{L2N}, f_{L3N}$	40.0 to 85.0 Hz	0.1 %	-
Voltage				
Source 1	$V_{L1N}, V_{L2N}, V_{L3N},$	0 to 650 kV	1 %	Transformer ratio selectable
Source 2	$V_{L1N}, V_{L2N}, V_{L3N},$	0 to 650 kV	1 %	Transformer ratio selectable
Current				
Load	I_{L1}, I_{L2}, I_{L3}	0 to 32,000 A	1 %	-
Max. value	I_{L1}, I_{L2}, I_{L3}	0 to 32,000 A	1 %	Slave pointer
Real power				
Current total real power value		-2 to 2 GW	2 %	Accuracy depends on the configured transformer ratios
Reactive power				
Current value in L1, L2, L3		-2 to 2 Gvar	2 %	Accuracy depends on the configured transformer ratios
cos ϕ				
Current value cos ϕ_{L1}		lag0.00 to 1.00 to lead0.00	2 %	-
Miscellaneous				
Real energy		0 to 4,200 GWh		not calibrated
Battery voltage		6.5 to 40 V	1 %	-

Reference conditions (to measure the accuracy):

- Input voltage sinusoidal rated voltage
- Input current..... sinusoidal rated current
- Frequency..... rated frequency +/- 2 %
- Power supply..... rated voltage +/- 2 %
- Power factor cos ϕ 1.00
- Ambient temperature..... 23 °C +/- 2 K
- Warm-up period 20 minutes

Appendix A.

Recommended Power Supply Units

Woodward recommends the use of the following external power supply units:

- Mean Well: DR-30-24
- Phoenix Contact: MINI-PS-100-240AC/24DC/1

An external buffered power supply solution may be achieved using the following devices:

- 2x Phoenix Contact: MINI-PS-100-240AC/24DC/1
- 1x Phoenix Contact: Quint-Buffer/24DC/20

We appreciate your comments about the content of our publications.
Please send comments to: industrial.support@woodward.com
Please include the manual number from the front cover of this publication.



Woodward GmbH
Handwerkstrasse 29 - 70565 Stuttgart - Germany
Phone +49 (0) 711 789 54-510 • Fax +49 (0) 711 789 54-101
industrial.support@woodward.com

Homepage

<http://www.woodward.com>

Woodward has company-owned plants, subsidiaries, and branches, as well as authorized distributors and other authorized service and sales facilities throughout the world.

Complete address/phone/fax/e-mail information
for all locations is available on our website (www.woodward.com).

2026/03/Stuttgart