

easYview Series

Technical Manual | mini SCADA

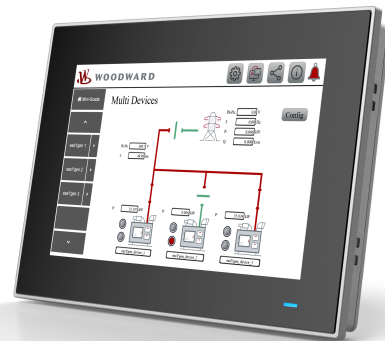
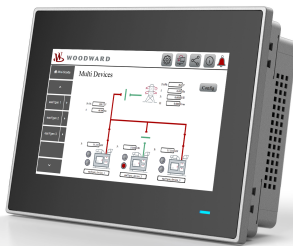
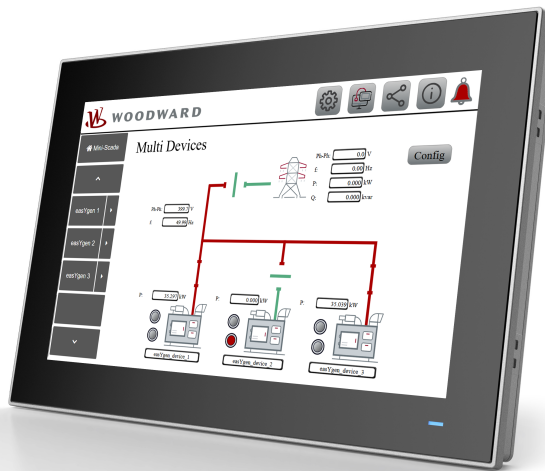

easYview-07-030 / 10-150 / 15-150

Release 3.0

Document ID: 37945, Revision F - Build 55098

Manual (original)

This is no translation but the original Technical Manual in English.

Designed in Germany, manufactured in Poland.

Woodward GmbH

Handwerkstr. 29

70565 Stuttgart

Germany

Telephone: +49 (0) 711 789 54-510

Fax: +49 (0) 711 789 54-101

E-mail: marketing_pg@woodward.com

Internet: <https://www.woodward.com>

© 2025 Woodward GmbH. All rights reserved.

Brief Overview

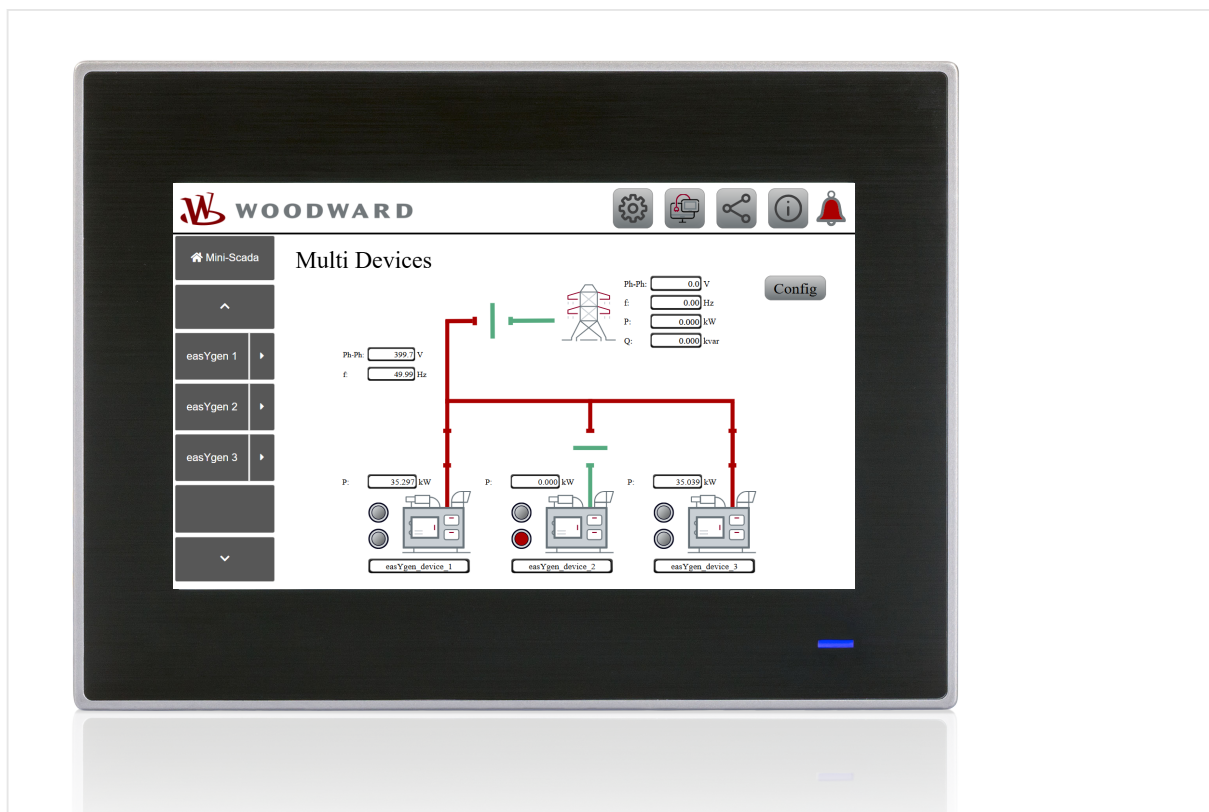

Woodward's easYview family is designed for switchgear builders, genset packagers and system integrators as an HMI option for any application where a secure remote control, monitoring, and visualization are desired, such as hospitals, data centers, offshore rigs, landfill and wastewater gas-to-power applications to name a few. This manual describes the easYview family panels: easYview-07-030, easYview-10-150 and easYview-15-150.

The easYview is a touch screen remote control and annunciation panel for use with the easYgen-3000XT or LS-6XT series controls. It is particularly useful with the back panel mounted easYgen-3100XT/3400XT or LS-6XT, providing control from the front panel with greatly reduced wiring to the access door, while keeping high voltage connections located safely on the back panel.

The easYview can be used in **Remote HMI mode** for remote control and visualization of one easYgen-3000XT or one LS-6XT device. It offers all the HMI resources that the display variants easYgen-3200XT/3500XT offer, but with the state of the art touch screen technology.

Additionally, it offers multi device visualization capability generally referred as SCADA system. It connects to XT-family controllers over Ethernet interface and provides a broad visualization data nodes over Modbus/TCP protocol.

In **mini-SCADA mode** the easYview offers a system visualization. It can connect **up to 3 (easYview-07-30) or up to 18 (easYview-10/15-150) devices at a time**. The off-the-shelf easYview HMI solution offers a visualization of four easYgen-3000XT in island or parallel to mains application. The easYview is designed to save customers engineering efforts in field for most common visualization topologies. However, we understand there is no one size fits all solution. Therefore, if your project requirements are not covered by off-the-shelf easYview it is possible to make customizations. Please refer to application note #37949 available at <http://www.woodward.com> or at the QR server <http://wwdmanuals.com/easyview>.

Supported devices

All easYgen-3000XT genset controls and LS-6XT are supported by the easYview-07-030, easYview-10-150 and easYview-15-150 remote panel.

Scope of delivery

The following parts are included in the scope of delivery. Please check prior to the installation that all parts are present.

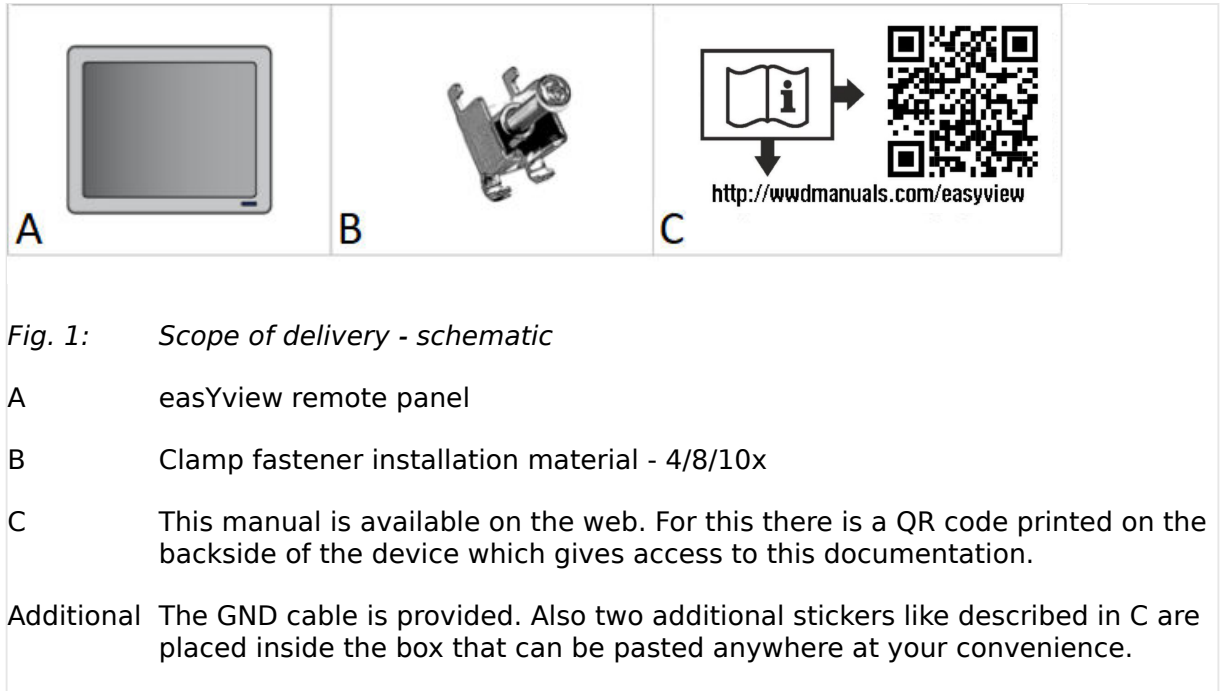

Table of Contents

1	General Information	8
1.1	Revision History	8
1.2	Depiction Of Notes And Instructions	10
1.2.1	Copyright And Disclaimer	11
1.2.2	Service And Warranty	12
1.3	Safety	12
1.3.1	Personnel	12
1.3.2	General Safety Notes	13
2	System Overview	15
2.1	System Overview mini-SCADA mode	16
2.2	System Overview Remote HMI mode	18
2.3	Hardware Overview	19
3	Installation	20
3.1	Mount Unit	20
3.1.1	Clamp Fastener Installation	24
3.2	Setup Connections	26
3.2.1	Terminal Allocation	26
3.2.2	Power Supply	27
3.2.3	Ethernet Interface	28
3.2.4	Ethernet Topology	30
3.2.5	Ethernet Topology Restrictions	30
3.2.5.1	mini-SCADA (Modbus) Topology	31
3.2.5.2	Remote HMI (VNC) Topology	34
4	Configuration	38
4.1	First time Setup	38
4.2	General configuration	39
4.3	Application Configuration	44
4.3.1	Setup Remote HMI mode	44
4.3.2	Setup mini-SCADA mode	44

Table of Contents

4.3.3	Change application mode	54
4.4	Password configuration	54
5	Operation	57
5.1	Remote HMI mode	57
5.1.1	The Remote HMI visualization	58
5.1.2	Remote HMI pages	59
5.1.2.1	Device List page	59
5.1.2.2	Single Remote HMI page	64
5.1.2.3	Multi Remote HMI page	66
5.1.2.4	Settings page	68
5.1.2.5	The Version Info page	68
5.2	mini-SCADA mode	69
5.2.1	The mini-SCADA visualization	70
5.2.2	mini-SCADA pages	73
5.2.2.1	The Multi Devices page	73
5.2.2.2	easYgen HOME page	75
5.2.2.3	Connection Settings page	78
5.2.2.4	The PC mode page	79
5.2.2.5	The Version Info page	80
5.3	Remote HMI Screen	81
5.4	Personalization	85
5.4.1	Change logo	85
5.4.2	Change Multi Devices Page	85
5.5	Licensing	86
6	Trouble Shooting	87
7	Third Party Software	89
8	Technical Specifications	90
8.1	Technical Data	90
8.1.1	Ambient Variables	90
8.1.2	System Hardware	91
8.1.3	Display	91

8.1.4 Touch Screen 92

8.1.5 Interface 92

8.1.6 Software 93

8.1.7 Housing 93

8.1.8 Approvals 94

8.1.9 Generic Note 94

9 Glossary And List Of Abbreviations 95

10 Index 96

1 General Information

1.1 Revision History

Rev.	Date	Editor	Changes
F	2025-09	MK	<p>Software Revision Release 3.0-0 or higher</p> <p>Manual corrections</p> <ul style="list-style-type: none"> • Corrected software release to 3.0-0 • Replaced device name easYview-10-060 by easYview-10-150 due to new license
E	2025-08	BS	<p>Software Revision Release 2.3-0 or higher</p> <p>Software update of the device easYview-10-150 and easYview-15-150 only.</p> <p>New features and functions</p> <ul style="list-style-type: none"> • Extended amount of Modbus connections to 18 • Added hardware code to info page <p>Correction/Repairs</p> <ul style="list-style-type: none"> • Fixed wrong location of pop-up windows when connecting over PC • Fixed resize issue of navigation bar when connecting over PC • Simplified navigation adjustment for customization
D	2025-02	BS	<p>Software Revision Release 2.2-0 or higher</p> <p>Software update of the device.</p> <p>Correction/Repairs</p> <ul style="list-style-type: none"> • mini-SCADA mode: Fixed Modbus TCP connection lost after approx 3 days • mini-SCADA mode: Restricted active Modbus TCP connections to three • mini-SCADA mode: Adjusted visualization to match new Modbus TCP restriction
C	2023-12	BS	<p>Software Revision Release 2.1-0 or higher</p> <p>Software update of the device.</p> <p>New features and functions</p> <ul style="list-style-type: none"> • New Remote HMI mode: <p>Multiple Remote HMI screens on one page, depending on display size (7inch=1x, 10inch=2x, 15inch=4x).</p>

Rev.	Date	Editor	Changes
			<p>List of available devices in network with a search filter options</p> <p>Auto Connection setting to the last connected device(s).</p> <p>Cascading feature to simple switch or duplicate Remote HMI screens on different easYview devices.</p> <ul style="list-style-type: none"> • mini-SCADA mode improvements: <p>Added LS6-XT connections to settings page.</p> <p>Extended connection settings to 8 devices (easYgen-XT/LS6-XT) for 10/15 inch easYview devices.</p> <p>Reduced required Modbus TCP connections from two to one for each easYgen-XT or LS6-XT device</p>
B	2023-07	MK	<p>Software Revision Release 2.0-0 or higher</p> <p>Hardware and software update of the device.</p> <p>New features and functions</p> <ul style="list-style-type: none"> • Fully Many-2-One visualization with integrated One-2-One mode software. • The screen of one easYgen-3000XT can be shown at up to 5 easYview in One-2-One mode.
A	2022-08	MK	<p>Introduction of the "easYview" as a remote operator control panel for One-2-One and Many-2-One visualization and remote control.</p> <p>Software Revision Release 1.0-0 or higher</p> <p>The easYview works together with easYgen-3000XT Software Revision Release 2.13-0 or higher. For lower versions there might be some restrictions. Please ask your Woodward sales support contact for details.</p>

1 General Information

1.2 Depiction Of Notes And Instructions

1.2 Depiction Of Notes And Instructions

Safety instructions

Safety instructions are marked with symbols in these instructions. The safety instructions are always introduced by signal words that express the extent of the danger.

DANGER!



This combination of symbol and signal word indicates an immediately-dangerous situation that could cause death or severe injuries if not avoided.

WARNING!



This combination of symbol and signal word indicates a possibly-dangerous situation that could cause death or severe injuries if it is not avoided.

CAUTION!



This combination of symbol and signal word indicates a possibly-dangerous situation that could cause slight injuries if it is not avoided.

NOTICE!



This combination of symbol and signal word indicates a possibly-dangerous situation that could cause property and environmental damage if it is not avoided.

Tips and recommendations



This symbol indicates useful tips and recommendations as well as information for efficient and trouble-free operation.

Additional markings

To emphasize instructions, results, lists, references and other elements, the following markings are used in these instructions:

Marking	Explanation
⚙	Start of a procedure list
>	Prerequisite for a procedure list
▷	Step-by-step instructions
▶	Results of action steps
↪	References to sections of these instructions and to other relevant documents

Marking	Explanation
•	Listing without fixed sequence
*	Example
»Buttons«	Operating elements (e.g. buttons, switches), display elements (e.g. signal lamps)
»Display«	Screen elements (e.g. buttons, programming of function keys)
[Screen xx / Screen xy / Screen xz] ...	Menu path. The following information and setting refer to a page on HMI screen or ToolKit located as described here.
	Some parameters/settings/screens are available only either in ToolKit or in HMI/display.



Dimensions in Figures

All dimensions shown with no units specified are in **mm**.

1.2.1 Copyright And Disclaimer

Disclaimer

All information and instructions in this manual have been provided under due consideration of applicable guidelines and regulations, the current and known state of the art, as well as our many years of in-house experience. Woodward assumes no liability for any damages due to:

- Failure to comply with the instructions in this manual
- Improper use / misuse
- Willful operation by non-authorized persons
- Unauthorized conversions or non-approved technical modifications
- Use of non-approved spare parts

The originator is solely liable for the full extent for damages caused by such conduct. The obligations agreed-upon in the delivery contract, the general terms and conditions, the manufacturer's delivery conditions, and the statutory regulations valid at the time the contract was concluded, apply.

Copyright

This manual is protected by copyright. No part of this manual may be reproduced in any form or incorporated into any information retrieval system without written permission of Woodward GmbH.

Delivery of this manual to third parties, duplication in any form - including excerpts - as well as exploitation and/or communication of the content, are not permitted without a written declaration of release by Woodward GmbH.

Actions to the contrary will entitle us to claim compensation for damages. We expressly reserve the right to raise any further accessory claims.

1.2.2 Service And Warranty

Our Customer Service is available for technical information.

For regional support, please refer to: ⇒ http://www.woodward.com/Support_pgd.aspx.

In addition, our employees are constantly interested in new information and experiences that arise from usage and could be valuable for the improvement of our products.

Warranty terms



Please enquire about the terms of warranty from your nearest Woodward representative.

For our contact search webpage please go to: ⇒ <http://www.woodward.com/Directory.aspx>

1.3 Safety

NOTICE!



Damage due to improper use!

Improper use of the device may cause damage to the device as well as connected components.

Improper use includes, but is not limited to:

- Storage, transport, and operation outside the specified conditions.

1.3.1 Personnel

WARNING!



Hazards due to insufficiently qualified personnel!

If unqualified personnel perform work on or with the control unit hazards may arise which can cause serious injury and substantial damage to property.

- Therefore, all work must only be carried out by appropriately qualified personnel.

This manual specifies the personnel qualifications required for the different areas of work, listed below:

Personnel:

- **Qualified electrician**

The qualified electrician is able to execute tasks on electrical equipment and independently detect and avoid any possible dangers due to his training, expertise and experience, as well as knowledge of all applicable regulations.

The qualified electrician has been specially trained for the work environment in where he is active and familiar with all relevant standards and regulations.

- **User**

The user operates the device within the limits of its intended use, without additional previous knowledge but according to the instructions and safety notes in this manual.

The workforce must only consist of persons who can be expected to carry out their work reliably. Persons with impaired reactions due to, for example, the consumption of drugs, alcohol, or medication are prohibited.

When selecting personnel, the age-related and occupation-related regulations governing the usage location must be observed.

1.3.2 General Safety Notes

Electrical hazards

DANGER!



Life-threatening hazard from electric shock!

There is an imminent life-threatening hazard from electric shocks from live parts. Damage to insulation or to specific components can pose a life-threatening hazard.

- Only a qualified electrician should perform work on the electrical equipment.
- Immediately switch off the power supply and have it repaired if there is damage to the insulation.
- Before beginning work at live parts of electrical systems and resources, cut the electricity and ensure it remains off for the duration of the work. Comply with the five safety rules in the process:
 - cut electricity;
 - safeguard against restart;
 - ensure electricity is not flowing;
 - earth and short-circuit; and
 - cover or shield neighboring live parts.
- Never bypass a fuse or render it inoperable. Always use the correct amperage when changing a fuse.
- Keep moisture away from live parts. Moisture can cause short circuits.

Prime mover safety

WARNING!



Hazards due to insufficient prime mover protection

The engine, turbine, or other type of prime mover should be equipped with an overspeed (over-temperature, or over-pressure, where applicable) shutdown device(s), that operates totally independently of the prime mover control device(s) to protect against runaway or damage to the engine, turbine, or other type of prime mover with possible personal injury or loss of life should the mechanical-hydraulic governor(s) or electric control(s), the actuator(s), fuel control(s), the driving mechanism(s), the linkage(s), or the controlled device(s) fail.

Modifications

WARNING!



Hazards due to unauthorized modifications

Any unauthorized modifications to or use of this equipment outside its specified mechanical, electrical, or other operating limits may cause personal injury and/or property damage, including damage to the equipment.

Any unauthorized modifications:

- constitute "misuse" and/or "negligence" within the meaning of the product warranty thereby excluding warranty coverage for any resulting damage
- invalidate product certifications or listings.

Use of batteries/alternators

NOTICE!



Damage to the control system due to improper handling

Disconnecting a battery from a control system that uses an alternator or battery-charging device whilst the charging device is still connected causes damage to the control system.

- Make sure the charging device is turned off before disconnecting the battery from the system.

2 System Overview

This chapter provides an overview of the easYview and its use in remote control applications.

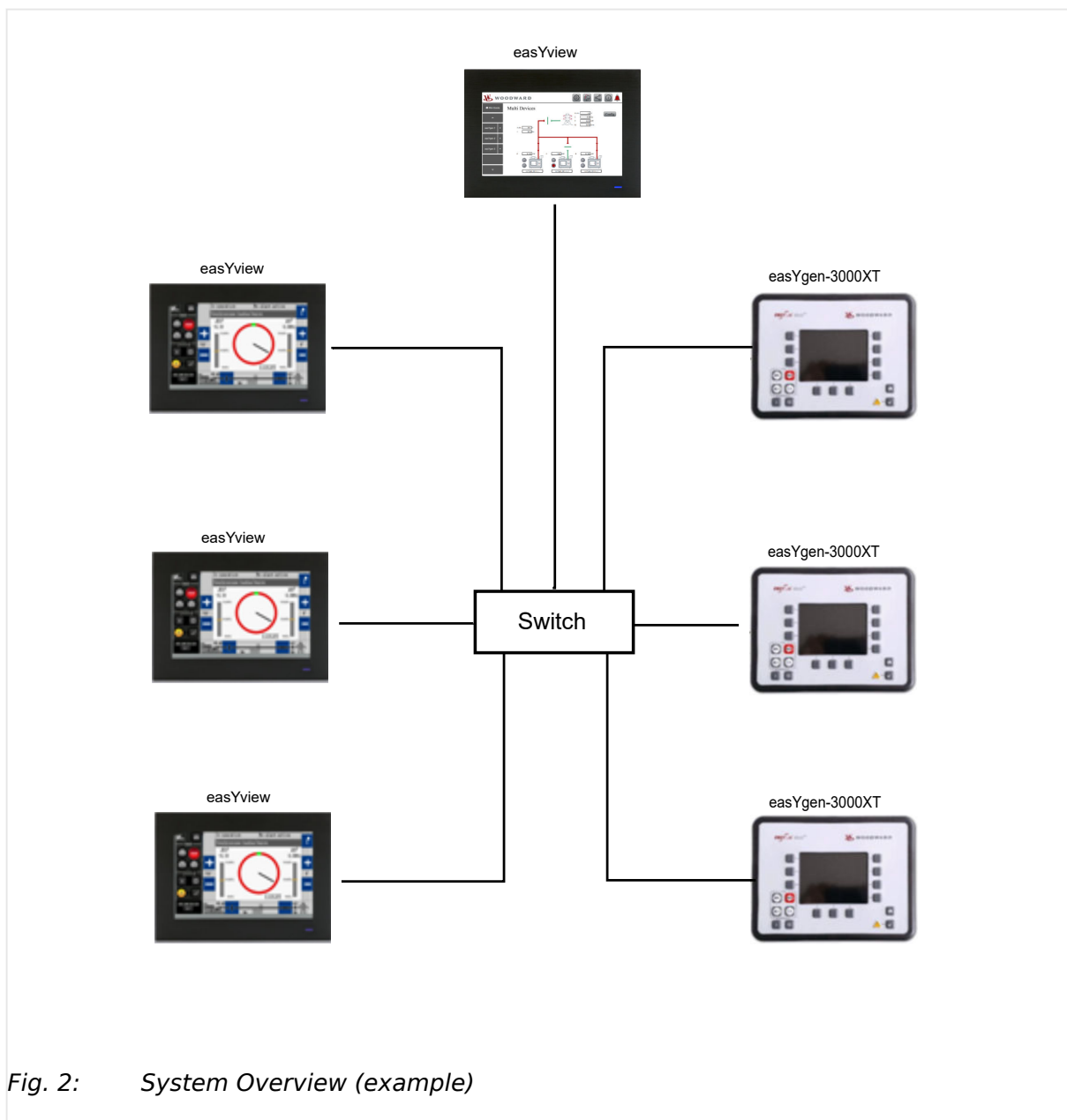

Fig. 2: System Overview (example)

The easYview has two basic application modes: a Remote HMI mode and a mini-SCADA mode.

- In the Remote HMI mode, the easYview connects to one or more devices via VNC technology and receives the Remote HMI screens of the connected easYgen-XT or LS6-XT devices.
- In the mini-SCADA mode, the easYview connects to multiple easYgen-XT or LS6-XT devices via Modbus TCP connection and offers a plant visualization.

The mini-SCADA mode has also a built-in Remote HMI capability to show the Remote HMI screen of the configured devices.

2 System Overview

2.1 System Overview mini-SCADA mode

Factory fitted easYview comes prepared with 3 (easYview-07-30) or 4 (easYview-10/15-150) easYgen-3000XT controllers. Tunables are available for minor customization such as, disabling an easYgen, changing color of live bus bar, changing utility source etc. However, for any major customization such as using a LS6-XT or 3rd party device instead of an easYgen, single line diagram according to your application etc, an Atvise Builder tool is required. The capability of having multi unit visualization is commonly referred as "mini-SCADA" mode. This mode is primarily designed to keep the visualized operator who wants to visualize most frequent / favorite values often from system perspective without going into details.

Additionally, for commissioning / troubleshooting phase, easYview offers possibility to connect to a single device with detailed parameter list. This mode is called "Remote HMI" mode.

Furthermore, easYview offers capability to cascade both modes to multiple easYview hardware.

2.1 System Overview mini-SCADA mode

Sample application setup mini-SCADA mode

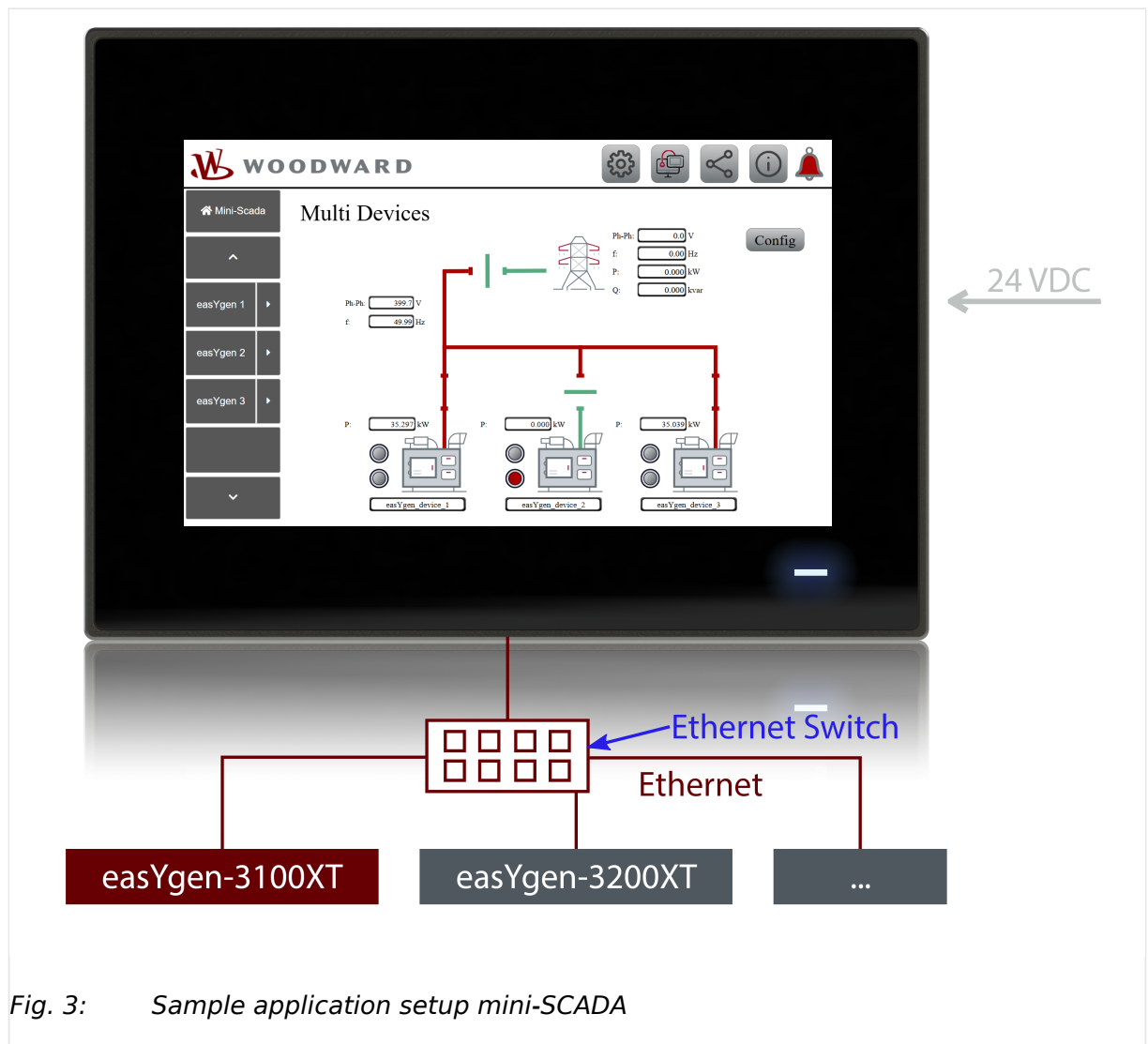

Fig. 3: Sample application setup mini-SCADA



easYview customization

The easYview factory set-up is designed for up to 3 (7 inch hardware) or 4 (10/15 inch hardware) easYgens in island or utility parallel operation. Tunables are available to customize this topology (such as less easYgens, color of live bus bar etc.).

However, it is also possible to implement customizations that require dedicated PC tools and/or programming (such as adding easYgens, making new SLD etc.). See application note #37949 available at <http://www.woodward.com> or at the QR server <http://wwdmanuals.com/easyview>.

Modifications

WARNING!



Hazards due to customer modifications

Please be advised that any customizations made to this product are done at the customer's own risk. Woodward does not assume any responsibility or liability for any performance issues, malfunctions, or damages that may result from such customizations. Our support in these cases is strictly limited to resetting the product to its factory default settings. By customizing this product, the customer acknowledges and accepts these terms.

A typical application for the easYview in this mode is to show a plant overview.

- In this mode, the easYview provides a system level overview where the most important information about the system performance is viewed quickly.
- And from the system level overview the user can jump quickly into a detailed device view. In addition, the user can drill-down further or tune variables.

Supported devices mini-SCADA mode

All easYgen-3000XT genset controls are supported by the off-the-shelf easYview-07-030, easYview-10-150 and easYview-15-150 in mini-SCADA mode. The off-the-shelf HMI solution offers a visualization of three easYgen-3000XT (for 7 inch hardware) and four easYgen-3000XT (for 10/15 inch hardware).



We intend to update/upgrade the easYview family regularly. Thereby providing support to other controllers (such as LS-6XT), introducing bigger display variants etc. Check with your Woodward representative to stay up to date.

2.2 System Overview Remote HMI mode

Sample application setup Remote HMI mode

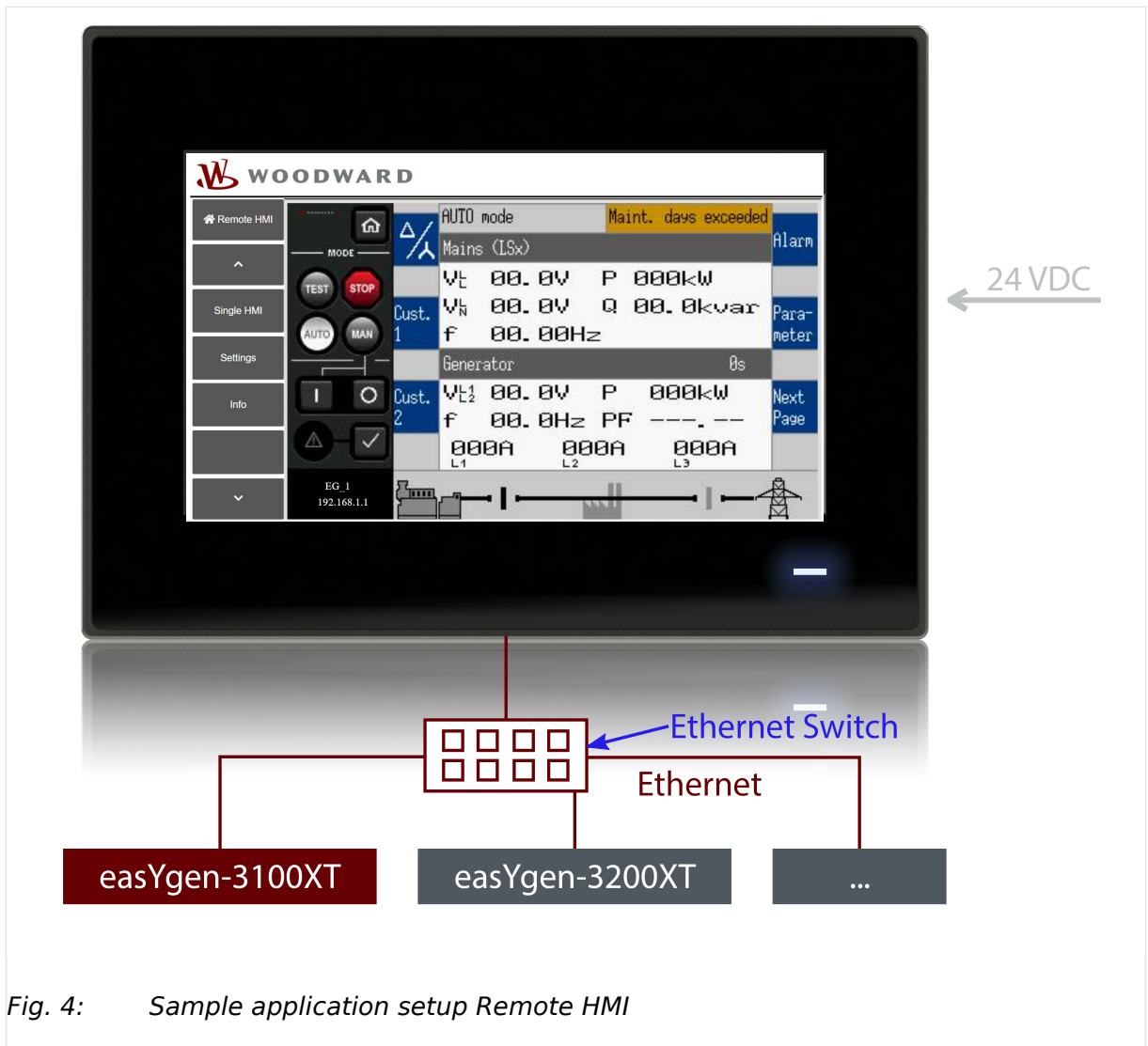

Fig. 4: Sample application setup Remote HMI



The easYview shows all available easYgen-3000XT or LS-6XT controls in the network, so a user can select the desired device. Depending on the easYview screen size (7", 10" or 15"), 1 to 4 different Remote HMI screen can be shown at the same time

A typical application for the remote panel is to control back-panel mounted easYgen-3000XT or LS-6XT devices.

- In this mode, the easYview provides control from the front panel with considerably reduced wiring effort.
- The high-voltage connections are located safely on the back panel at the easYgen-3000XT or LS-6XT.

Supported devices Remote HMI mode

All easYgen-3000XT genset controls and all LS-6XT are supported by the easYview remote panel in Remote HMI mode.

2.3 Hardware Overview**easYview Display**

The touch screen display (↳ Fig. 4) as part of the easYview is used for direct access to status information and configuration.

Status Indicator

At the lower right corner of the easYview there is a LED bar with following states:

- Illuminated (blue): Power ON, device is working
- Illuminated (orange): Standby
- NOT illuminated: Power OFF or fatal device error

Hardware Interfaces (Terminals)

The easYview provides the following terminals -- only two of them, marked green, are used. They are allocated as follows:

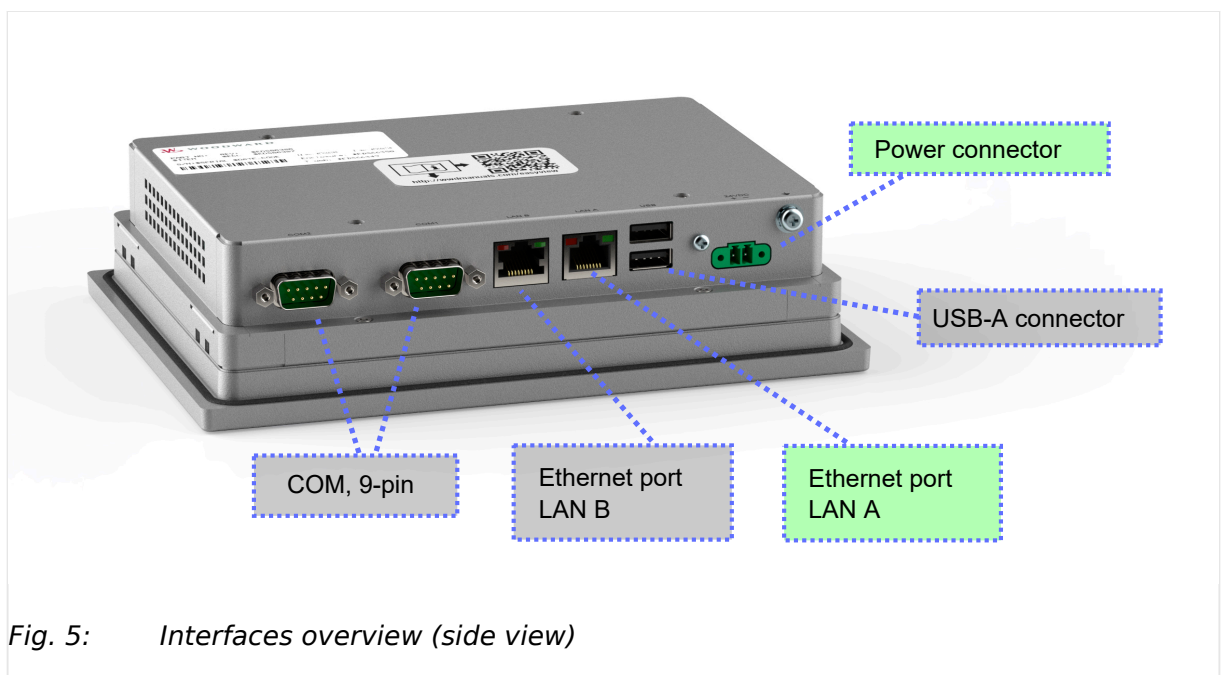

Fig. 5: Interfaces overview (side view)

**Restricted use of interfaces**

For use with easYgen-3000XT or LS-6XT devices only two terminals are used:

- Power supply
- ETHERNET port LAN A

3 Installation

3.1 Mount Unit

Mount the unit using the clamp fasteners (↳ “3.1.1 Clamp Fastener Installation”).



- Don't drill holes if you want to use the clamp fasteners. If the holes are drilled into the panel, the clamp fasteners cannot be used anymore.
- In order to ensure the protection of IP 66, fasten the unit with adequate care.

7" Panel: easYview-07-030

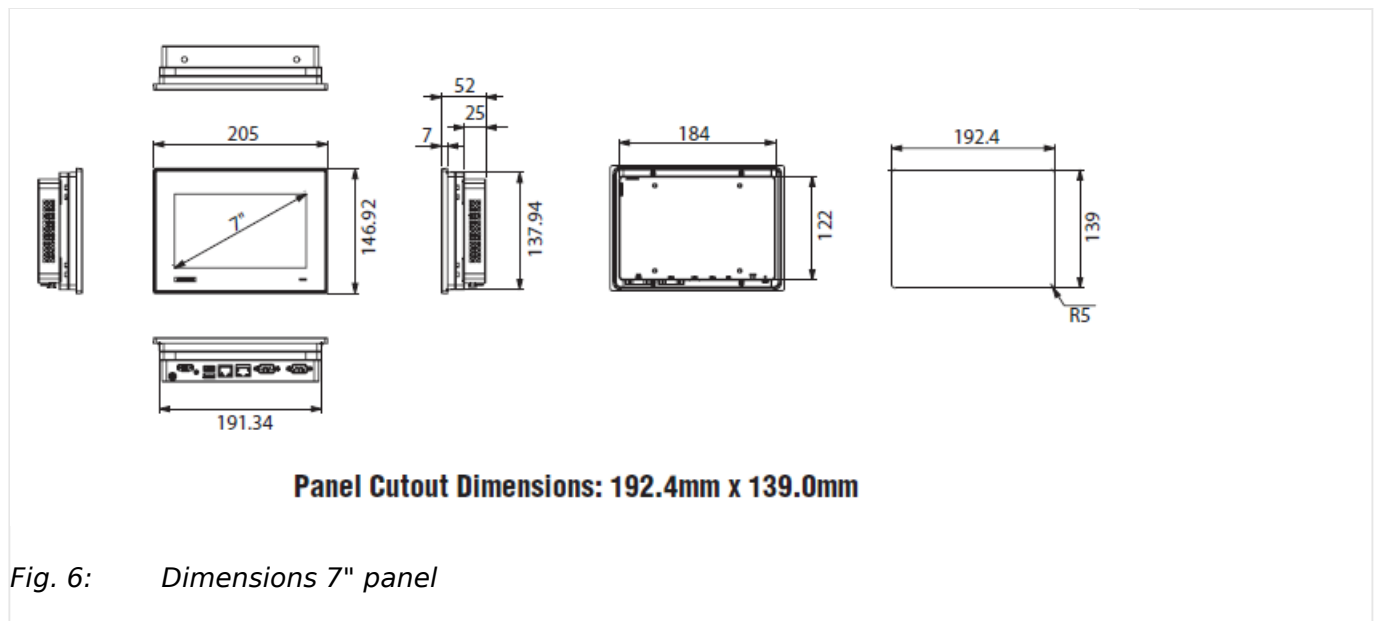

Panel cutout

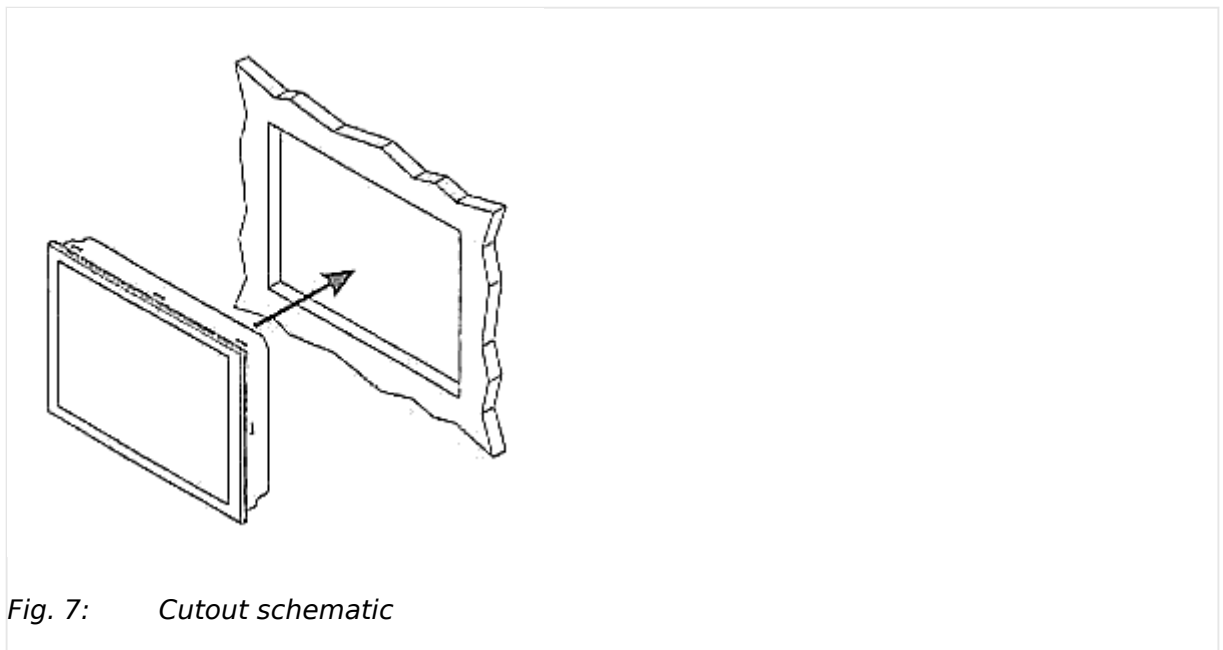

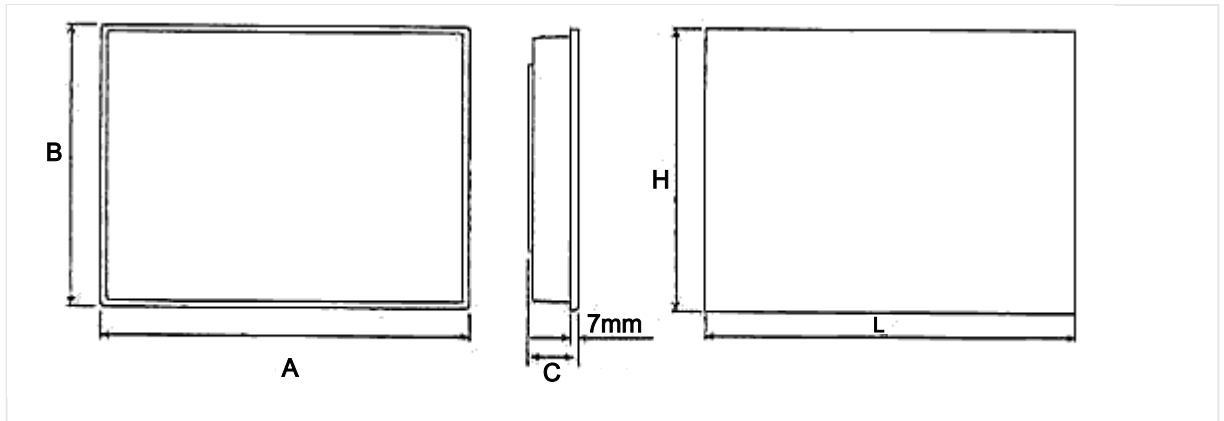

Fig. 8: Dimension and cut out

Measure	Description		
B	Height	Total height	146.92 mm
H		Panel cutout height	139 mm
A	Width	Total width	205 mm
L		Panel cutout width	192.4 mm
C	Depth	Total depth	52 mm

Table 1: Dimension and cut out 7" panel



The maximum permissible corner radius is 5 mm.

10" Panel: easYview-10-150

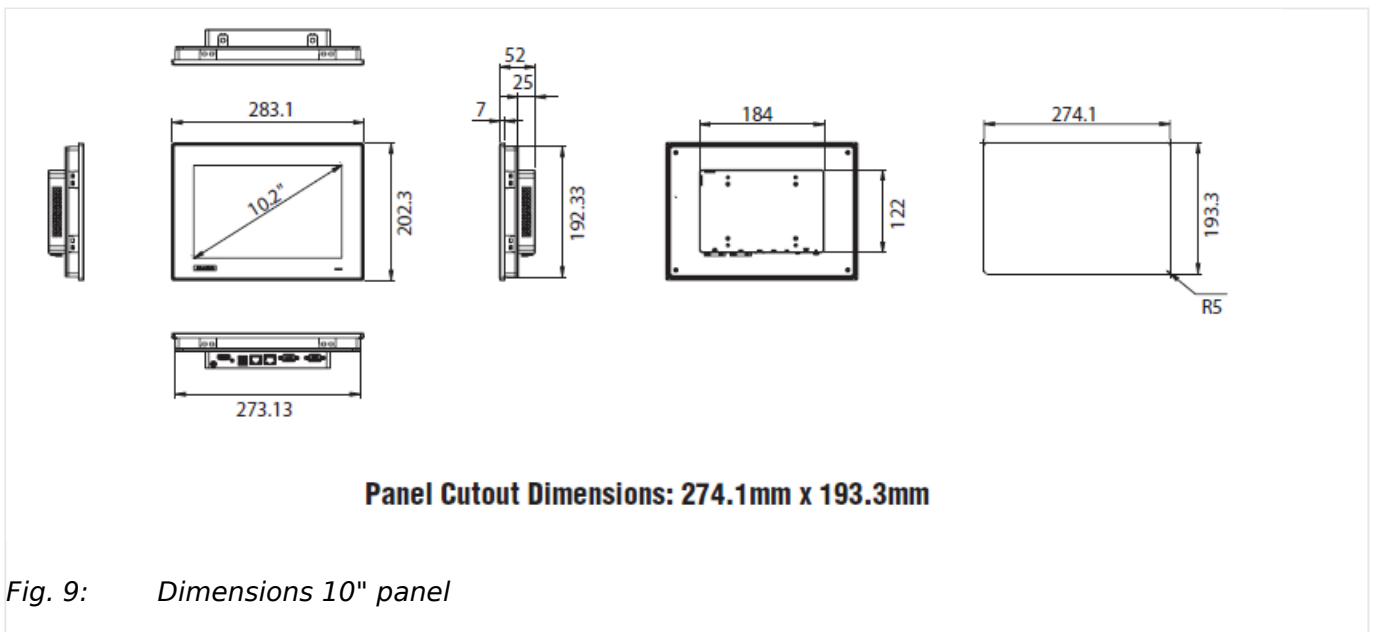

Fig. 9: Dimensions 10" panel

3 Installation
3.1 Mount Unit

Panel cutout

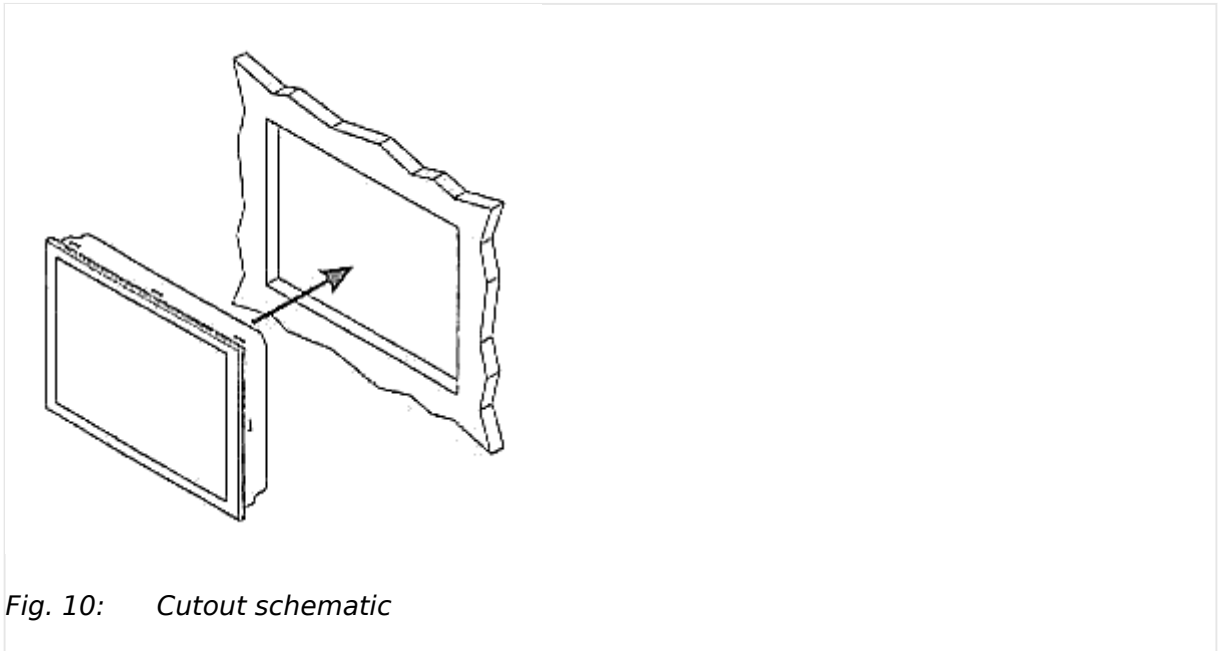

Fig. 10: Cutout schematic

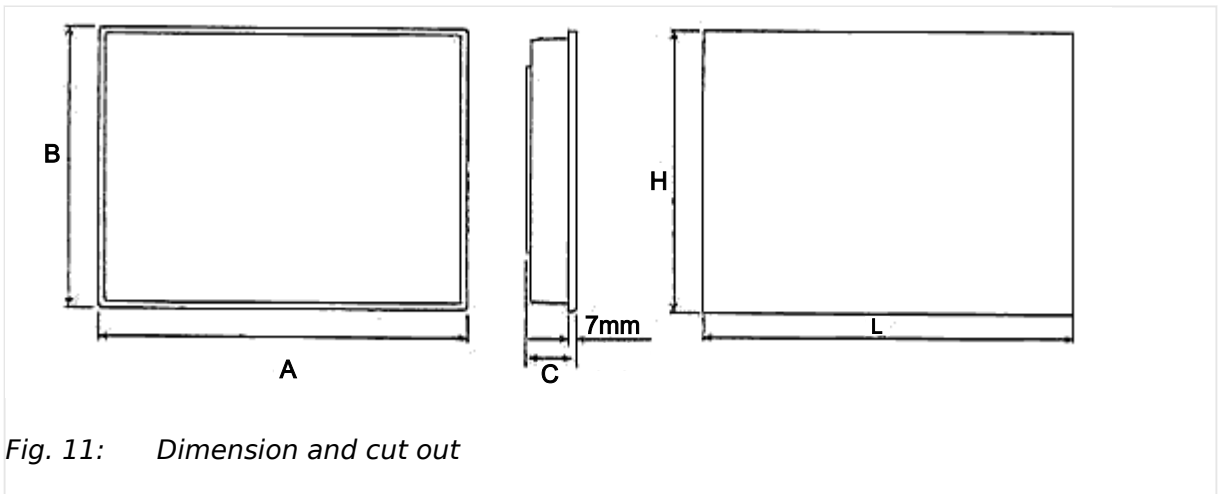

Fig. 11: Dimension and cut out

Measure	Description		
B	Height	Total height	202.3 mm
H		Panel cutout height	193.3 mm
A	Width	Total width	283.1 mm
L		Panel cutout width	274.1 mm
C	Depth	Total depth	52 mm

Table 2: Dimension and cut out 10" panel



The maximum permissible corner radius is 5 mm.

15" Panel: easYview-15-150

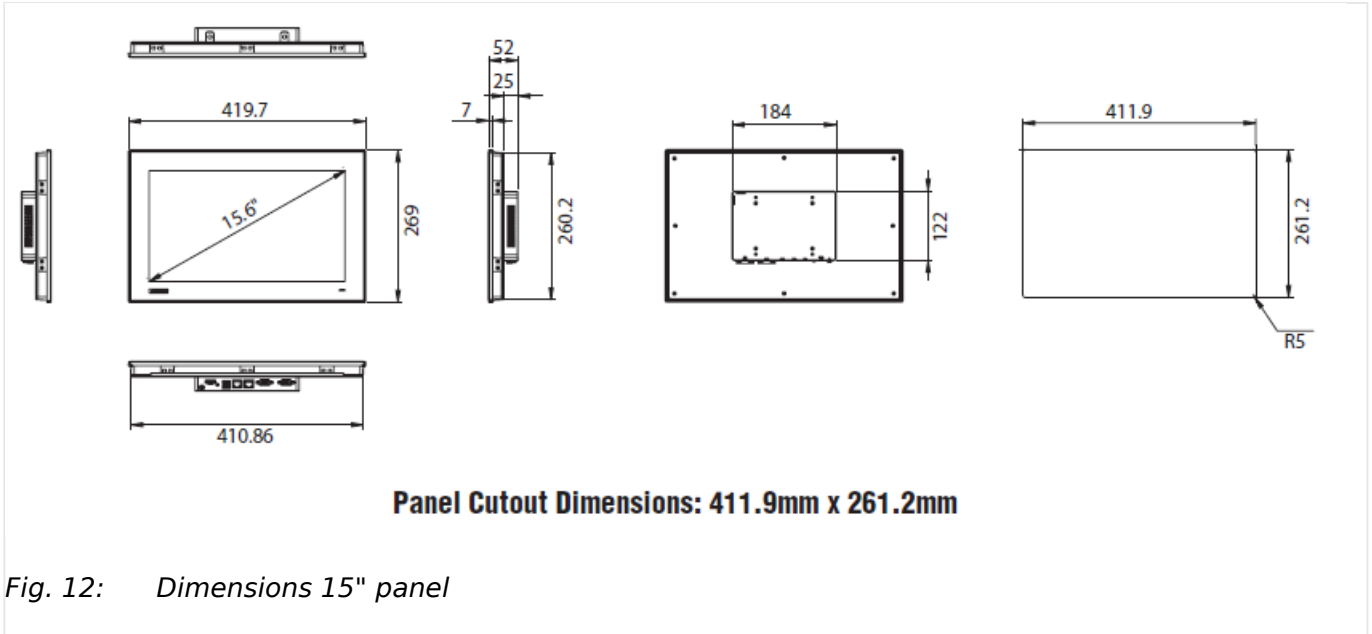

Fig. 12: Dimensions 15" panel

Panel cutout

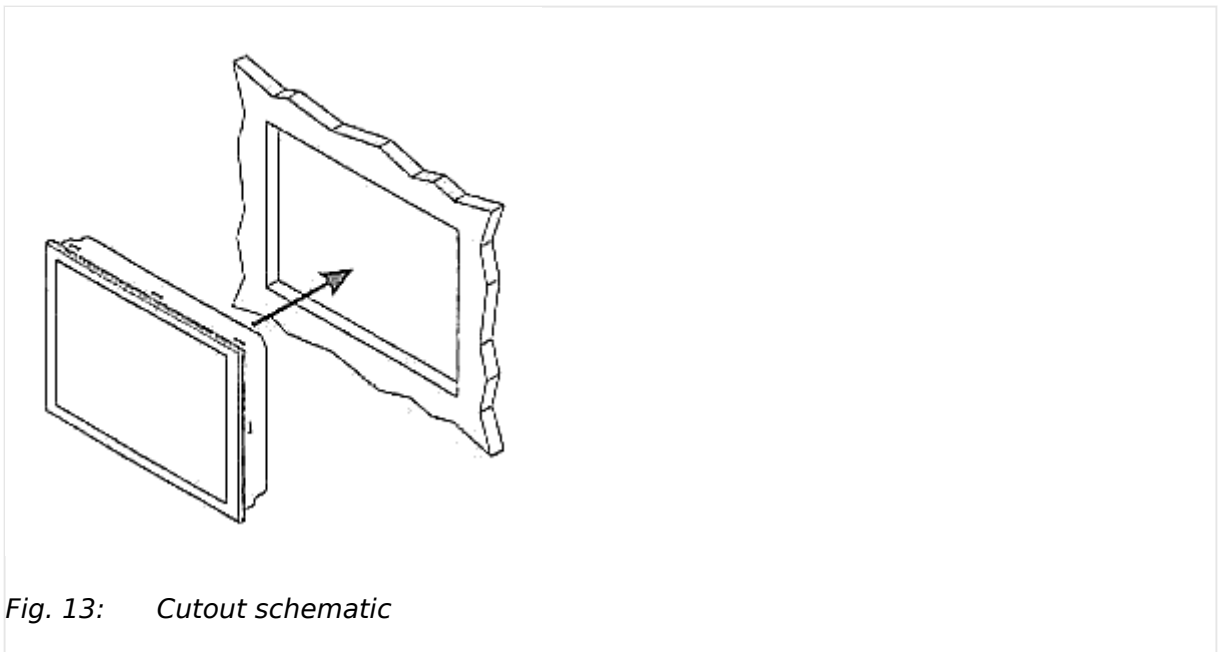

Fig. 13: Cutout schematic

3 Installation

3.1.1 Clamp Fastener Installation

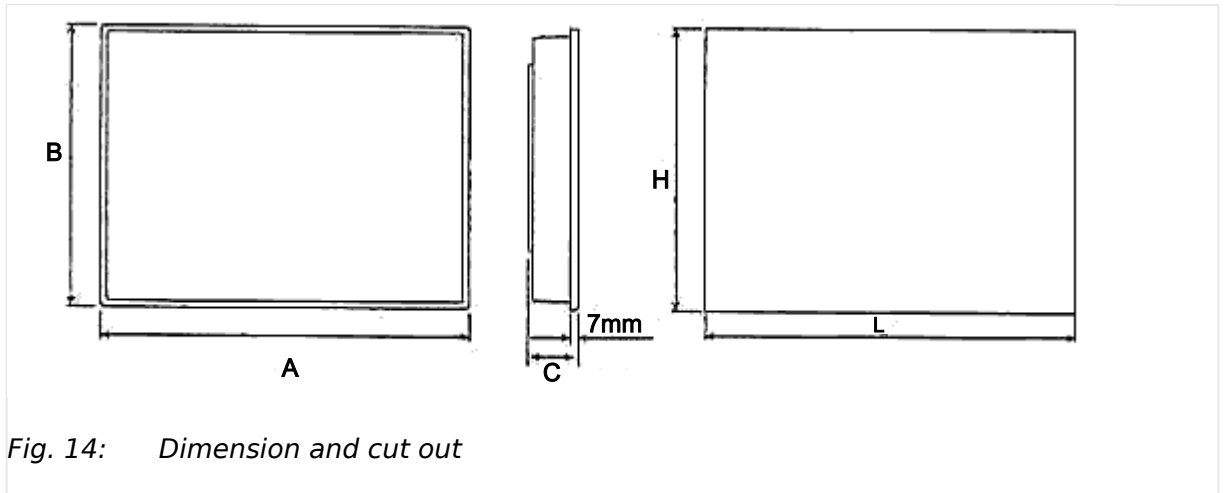

Fig. 14: Dimension and cut out

Measure	Description		
B	Height	Total height	269 mm
H		Panel cutout height	261.2 mm
A	Width	Total width	419.7 mm
L		Panel cutout width	411.9 mm
C	Depth	Total depth	52 mm

Table 3: Dimension and cut out 15" panel



The maximum permissible corner radius is 5 mm.

3.1.1 Clamp Fastener Installation



> For installation into a door panel with the fastening clamps, proceed as follows:

1. > Cut out the panel according to the dimensions in [Fig. 7](#) or [Fig. 10](#) or [Fig. 13](#).



Don't drill holes if you want to use the clamp fasteners. If holes are drilled into the panel, the clamp fasteners cannot be used anymore!

2. > Loosen the wire connection terminal screws on the back of the unit and remove the wire connection terminal strip if required.
3. > Insert the four/eight/ten clamping screws into the clamp inserts until they are almost flush. Do not completely insert the screws into the clamp inserts.

- 4.** ▷ Insert the unit into the panel cutout. Verify that the unit fits correctly in the cutout. If the panel cutout is not big enough, enlarge it accordingly.

- 5.** ▷

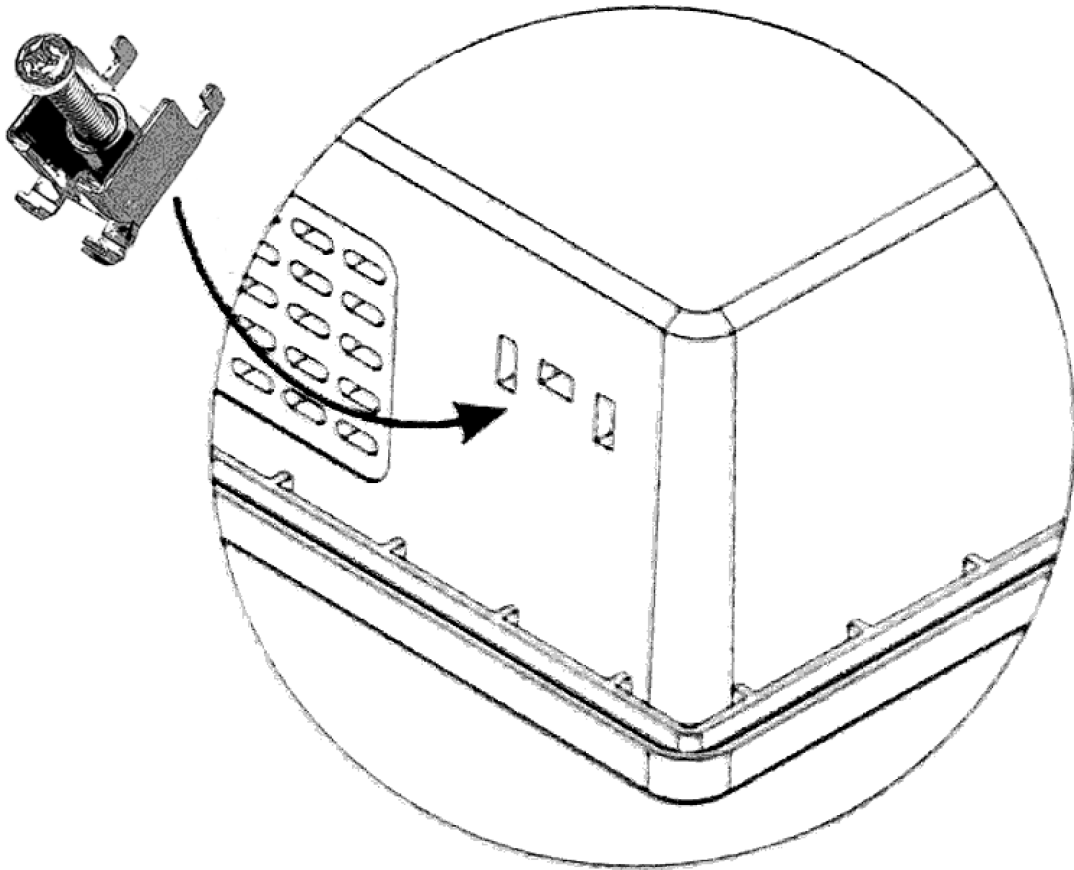

Fig. 15: mount

Insert the noses of the insert into the slots of the housing. Do it for all four/eight/ten clamp fasteners on all sides of the device.

- 6.** ▷ Tighten the clamping screws until the control unit is secured to the control panel. Over tightening of these screws may result in the clamp inserts or the housing breaking.
- 7.** ▷ Re-attach the wire connection terminal strip and secure them.

3.2 Setup Connections

3.2.1 Terminal Allocation

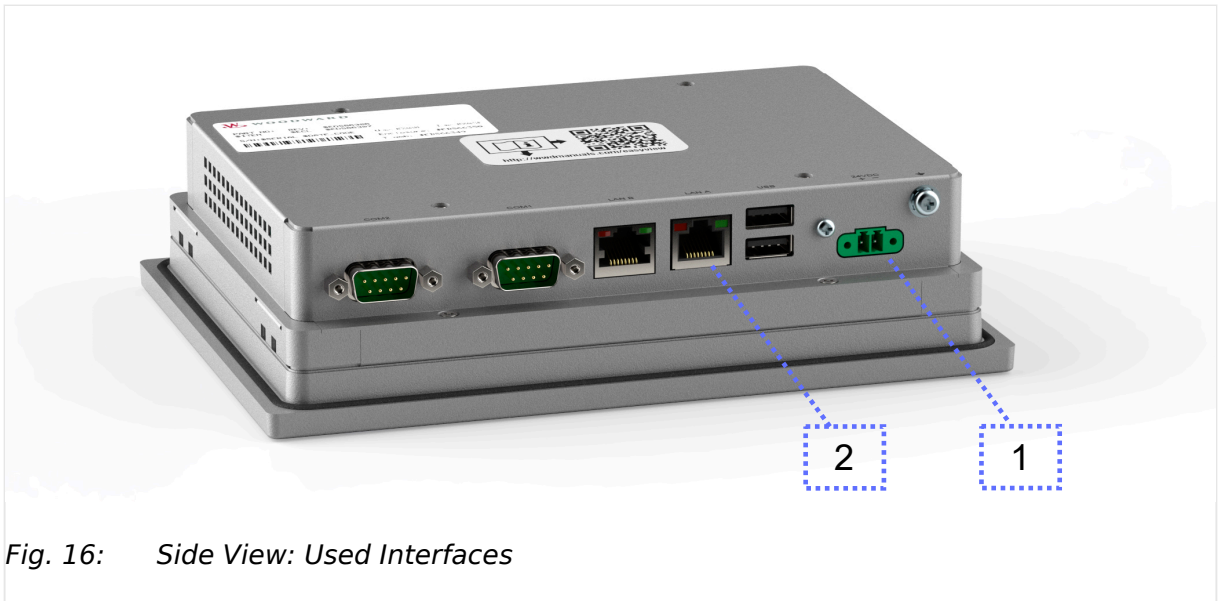
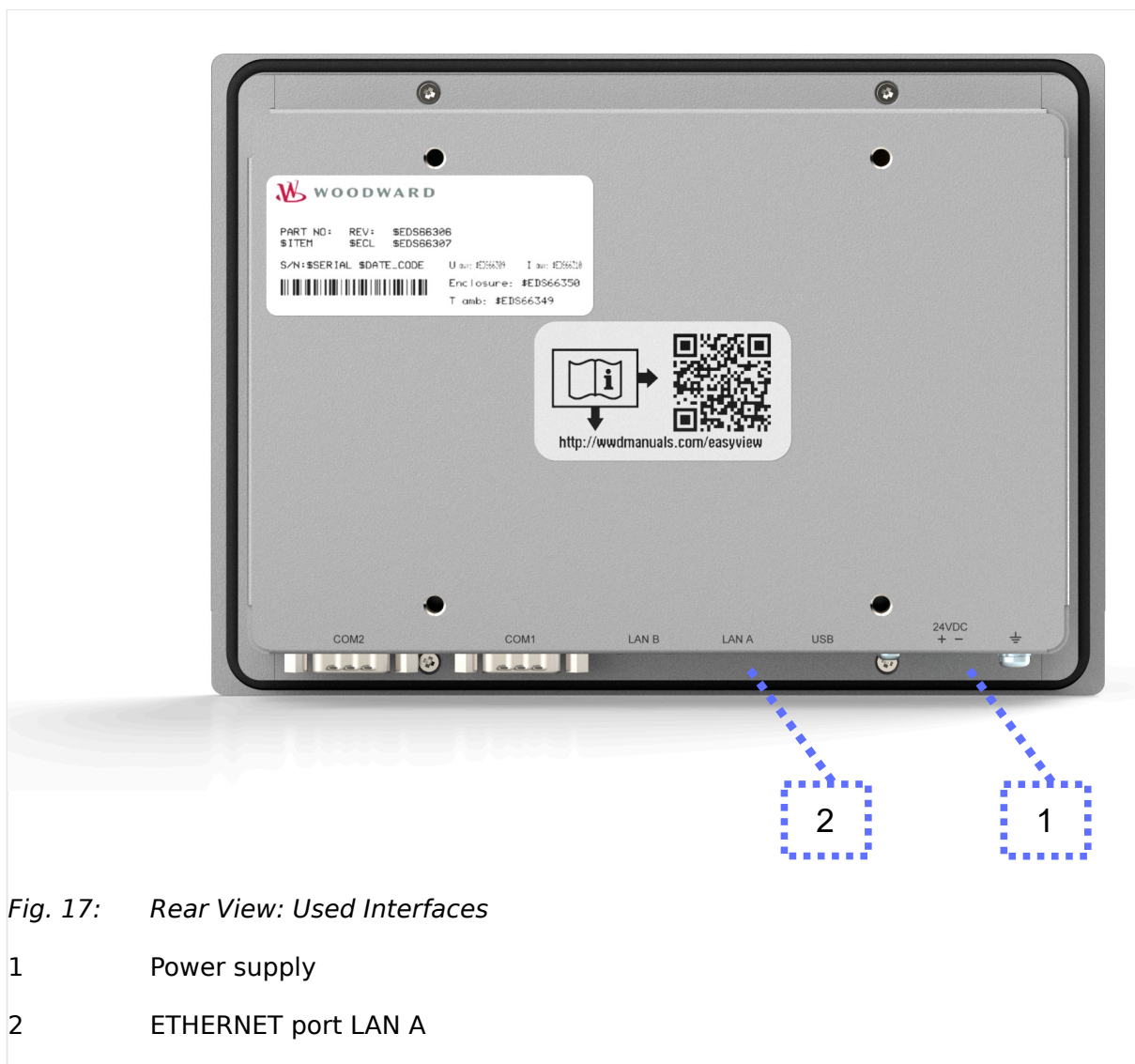

Fig. 16: Side View: Used Interfaces



3.2.2 Power Supply

General notes

Terminal 1: Low voltage / Limited Energy power source. See drawing [↳](#) “3.2.1 Terminal Allocation”.

Schematic and terminals

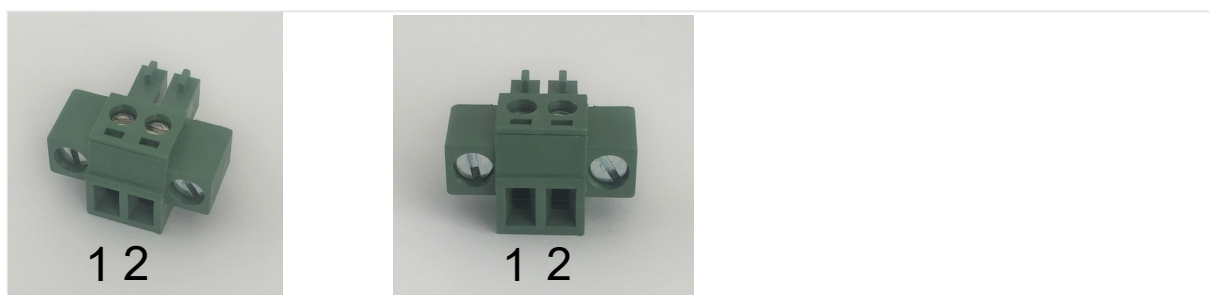

Fig. 18: Power supply - wiring

3 Installation

3.2.3 Ethernet Interface

Terminal		Description	A _{max}
1	24 V	+24V _{DC} +/- 20%	1.5 mm ²
2	0 V	0 V _{DC} (Common M)	1.5 mm ²

Table 4: Power supply - terminal assignment

The Ground is connected to the housing of the easYview via a separate cable. This yellow-green cable is delivered with the easYview device.



Fig. 19: GND - wiring

Wire sizes



Field wiring shall be made with use of cables which have temperature rating not less than 90 °C.

AWG	mm ²	AWG	mm ²	AWG	mm ²	AWG	mm ²	AWG	mm ²	AWG	mm ²
30	0.05	21	0.38	14	2.5	4	25	3/0	95	600MCM	300
28	0.08	20	0.5	12	4	2	35	4/0	120	750MCM	400
26	0.14	18	0.75	10	6	1	50	300MCM	150	1000MCM	500
24	0.25	17	1.0	8	10	1/0	55	350MCM	185		
22	0.34	16	1.5	6	16	2/0	70	500MCM	240		

Table 5: Conversion chart - wire sizes

3.2.3 Ethernet Interface

General notes

The following chapter describes some Ethernet network issues that are essential to ensure that the system works fine connecting the easYview and the easYgen-3000XT series candidate.



Avoid electrostatic discharge!

Avoid electrostatic discharge during Ethernet cable connection to the unit.

Visualization

Two LEDs (green and yellow) at the RJ45 connector indicate communication status as well known by the standard.

- The green LED indicates the link activity: blinking during data transmission.
- The yellow LED indicates the link (speed) status:
 - 10MB - LED switched-OFF
 - 100MB - LED switched-ON

General notes

Ethernet category 5 (CAT 5) cable is required with plug RJ45. The chosen switch shall support a transmission speed of 10/100 Mb/s with a network segment expansion capability of 100 m.

Cable length / distance

The maximum length from connection to connection is 100 m. Some third party suppliers offer technology to expand the connection.

Topology

Use LAN A of the easYview to set-up the Ethernet connection.

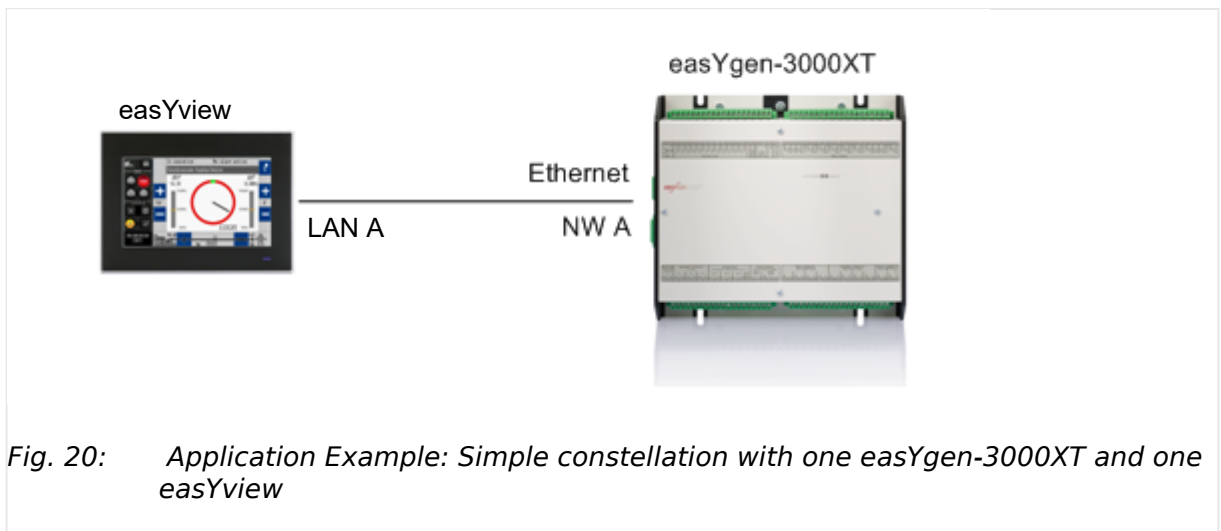
**Troubleshooting**

Check first the power supply of the switches.

Check if the Ethernet connection is established via LAN A of the easYview.

Check the IP addresses of the single devices. See chapter [↳ “4.1 First time Setup”](#) for details.

Bus shielding

This is usually covered by the cable assembly, like the CAT 5 cable.

3 Installation

3.2.4 Ethernet Topology

Troubleshooting

Woodward recommends the use of shielded twisted-pair cables for the Ethernet bus.

3.2.4 Ethernet Topology

All devices which shall communicate with each other, must be connected over Ethernet (LAN/NW A port) and the IP addresses must be in same network area (subnet). For further information, refer to [3.2.5 Ethernet Topology Restrictions](#).

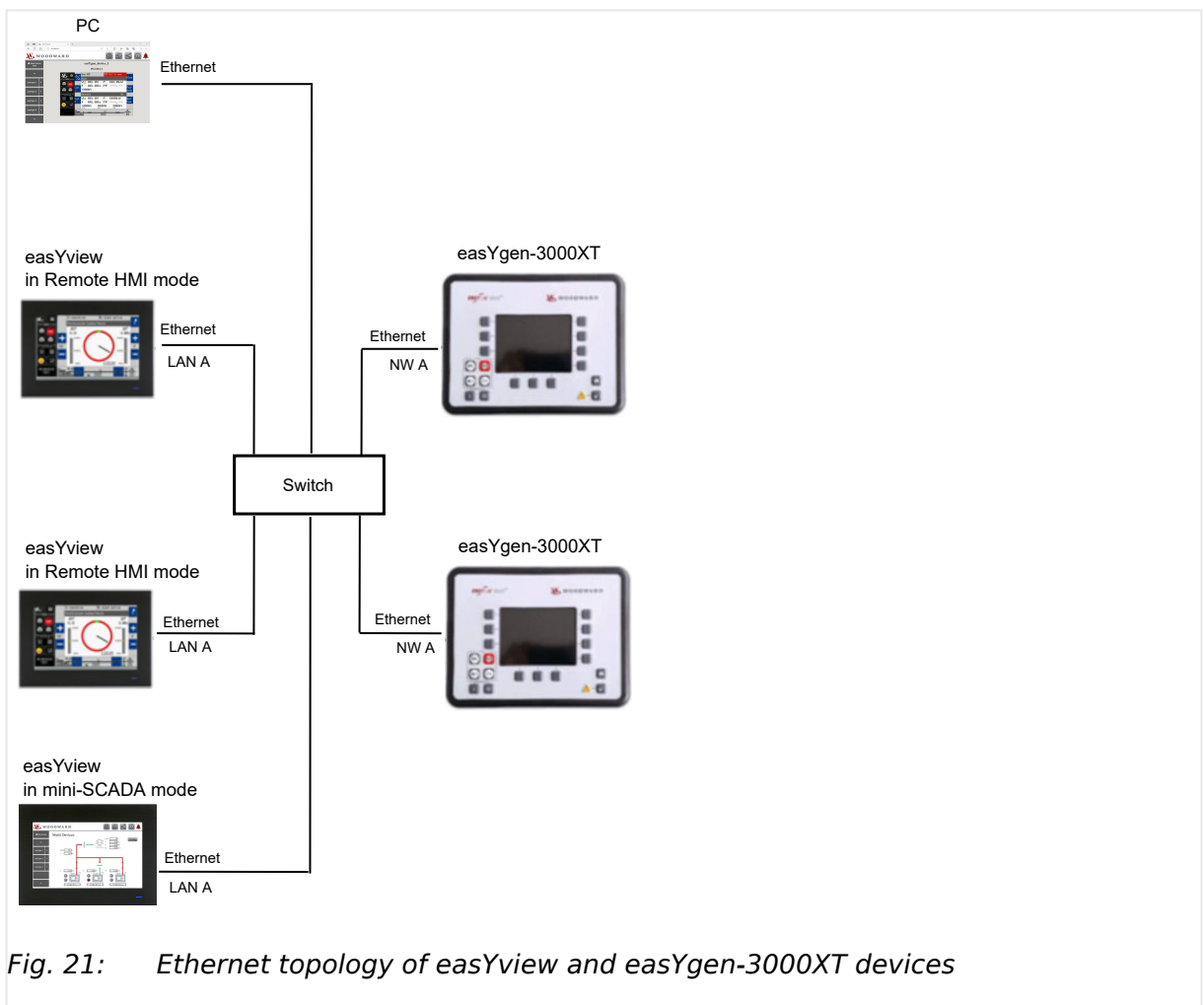
**3.2.5 Ethernet Topology Restrictions**

To set up a functional system there are different restrictions to consider, which are described in the following sub-chapters.

For Modbus TCP restrictions, refer to [3.2.5.1 mini-SCADA \(Modbus\) Topology](#)

For Remote HMI restrictions, refer to [3.2.5.2 Remote HMI \(VNC\) Topology](#)

3.2.5.1 mini-SCADA (Modbus) Topology

In the mini-SCADA mode, the easYview receives data from easYgen-XT devices over Modbus TCP. For this purpose, the easYview device uses one MODBUS TCP connection (to each easYgen-3000XT device). The easYgen-3000XT can support up to 5 MODBUS TCP connections. Which means that a maximum of five easYview devices can show the same Modbus data (mini-SCADA) of one easYgen-3000XT device. With the supplied visualization, one easYview device can show the Modbus data of maximum 3 (7 inch hardware) or 18 (10/15 inch hardware) different easYgen-3000XT and LS-6XT devices. Of course, with the help of "Atvise" software and personalization/customization of easYview to own needs, it is possible to visualize more data of each easYgen-3000XT device or visualize data of a LS-6XT instead of an easYgen-3000XT. The following examples shall demonstrate the restriction with the supplied visualization.

3.2.5.1.1 Modbus application examples



All connection lines in the following examples represent an active communication (Modbus TCP) between devices. The devices are still all connected to the same Network over a Ethernet switch.

3 Installation

3.2.5.1.1 Modbus application examples

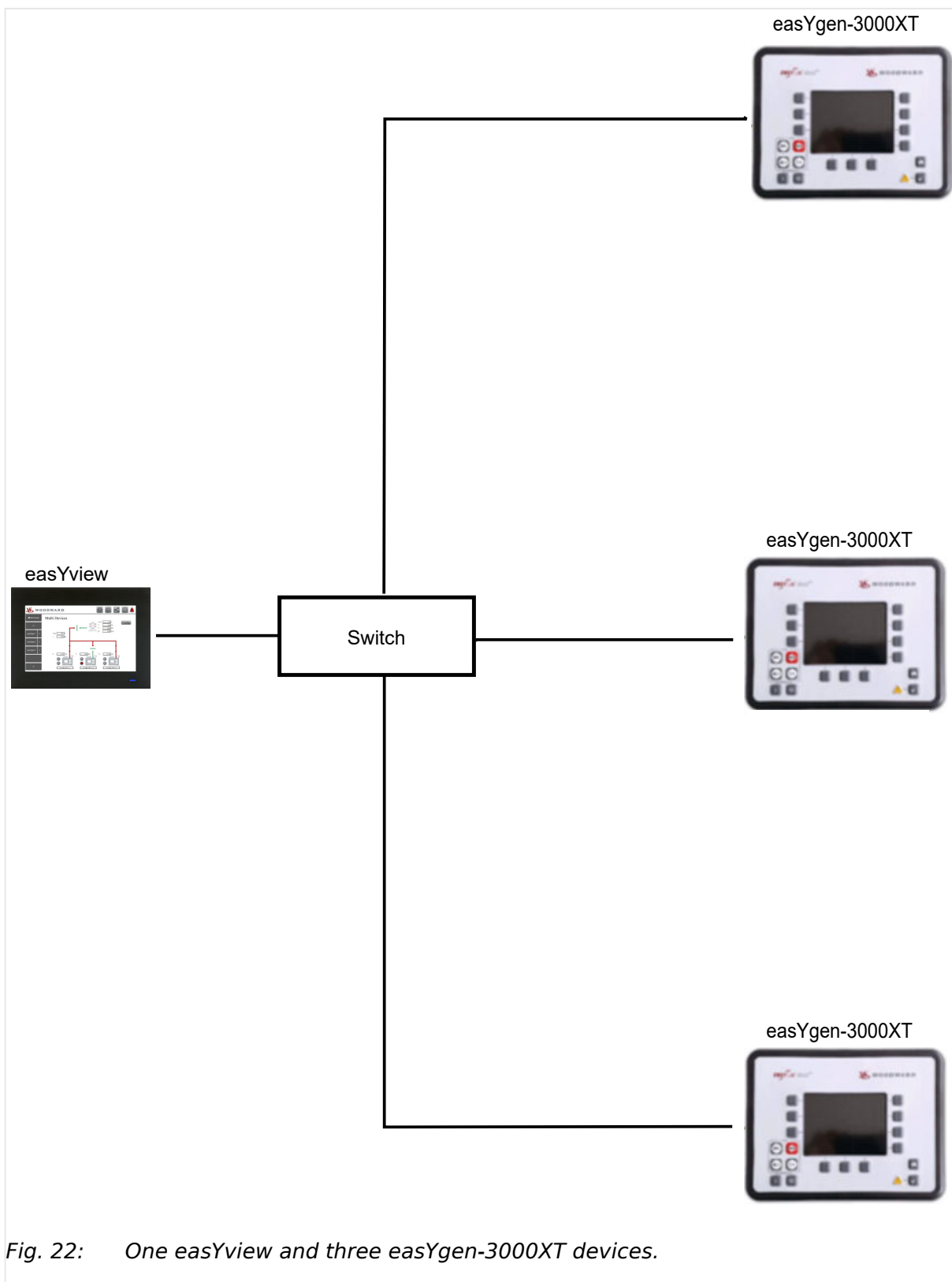
Modbus TCP connection between one easYview and three easYgen-3000XT

In this example one easYview has a Modbus TCP connection to each of the three easYgen-3000XT devices. The easYview can show all data of the three easYgen-3000XT devices in the default supplied visualization.

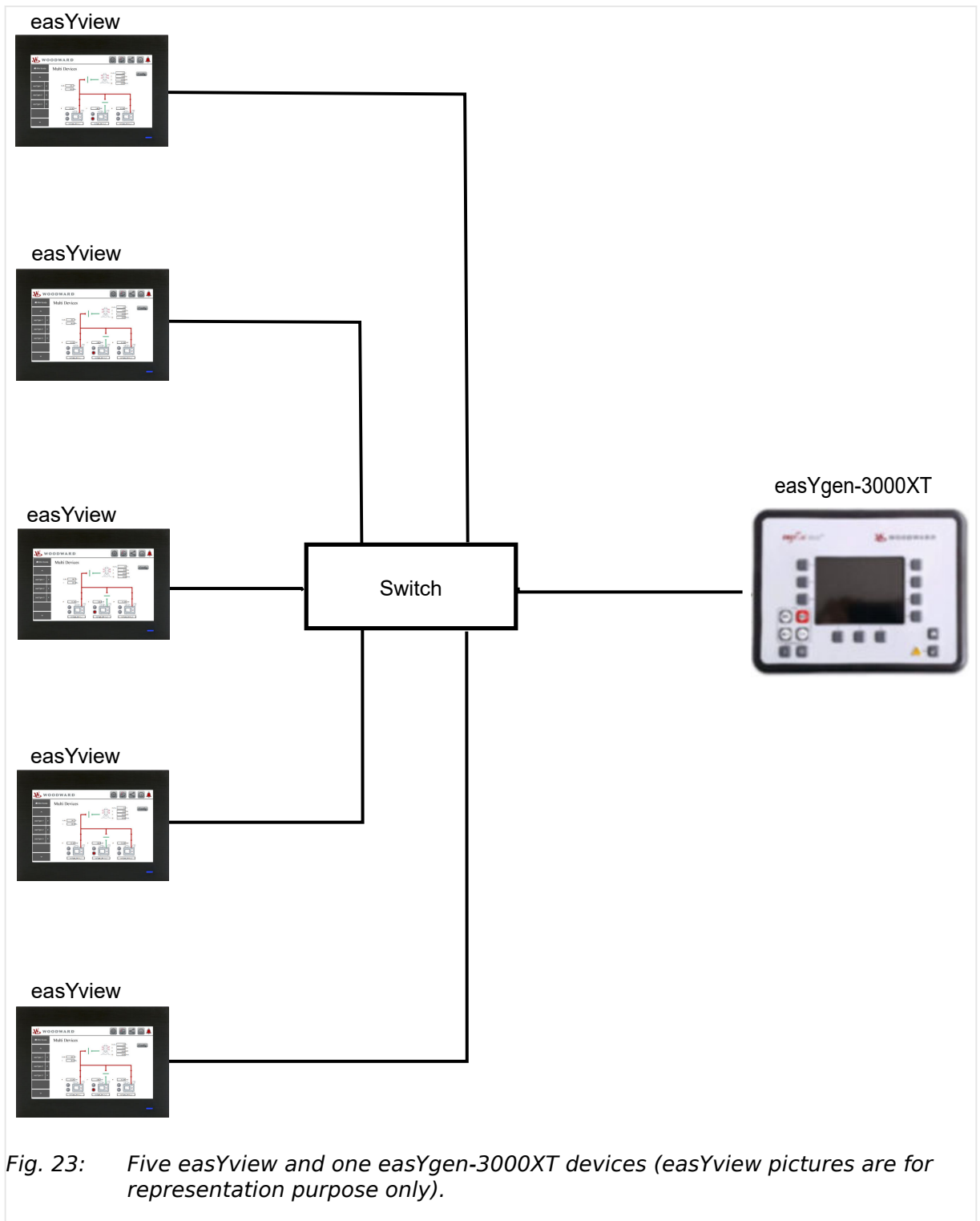
Modbus TCP connection between five easYview and one easYgen-3000XT

This example show five easYview and one easYgen-3000XT devices. Each easYview has one Modbus TCP connection to the easYgen-3000XT and can show the data in the visualization.

3 Installation

3.2.5.2 Remote HMI (VNC) Topology



Of course various combinations between example [↪ Fig. 22](#) and [↪ Fig. 23](#) are possible.

3.2.5.2 Remote HMI (VNC) Topology

An easYview can show the duplicated HMI screen (Remote HMI screen) of an easYgen-3000XT or LS6-XT by create a Remote HMI connection (VNC connection).

A Remote HMI feature can be used from both application modes:

- mini-SCADA mode: By pressing the Remote HMI button  from the [↪ “5.2.2.2 easYgen HOME page”](#). This will show the Remote HMI screen of the easYgen-XT based on the [↪ “5.2.2.3 Connection Settings page”](#).
- Remote HMI mode: By selecting any device (easYgen-XT or LS6-XT) from the [↪ “5.1.2.1 Device List page”](#). For easYview devices with bigger display sizes (10/15inch), more Remote HMI screens can be shown at the same time.

3.2.5.2.1 General Remote HMI rules

- The easYview and the easYgen-3000XT or LS6-XT devices have to be in the same Network, refer to General Settings.
- One easYgen-3000XT or LS6-XT can only have one active Remote HMI connection to an easYview.
- An easYview can show 1-4 Remote HMI screen of an easYgen-3000XT or LS6-XT (depending on the display size).
- The easYview can create up to 5 instances of the VNC Server (only needed if cascading feature is used). Each instance can create a Remote HMI connection to an easYgen-3000XT or LS6-XT.
- A easYview (Slave) can request a Remote HMI screen from another easYview (Master), refer to cascading feature.

3.2.5.2.2 Cascading feature

The cascading feature of the easYview can be seen as Master/Slave behavior of multiple easYview devices to manage different Remote HMI connections.

To configure the cascading feature, refer to [↪ “4.2 General configuration”](#)

Without using the cascading feature

Each easYgen-XT or LS6-XT device can only have one active VNC connection. Therefore, in a system of multiple easYview devices without configured cascading feature an easYview can not show the Remote HMI screen which is already shown on a different easYview. To show the same Remote HMI screen on another easYview device, the Remote HMI connection first needs to be released (switch to a different page, for instance). This is inconvenient for systems with multiple easYview devices, especially if each easYview

shall switch between different Remote HMI connections. Therefore, the easYview can be used with a Master/Slave configuration.

easYview	Setting "Remote HMI" / "Use own IP"	IP address (of Master easYview)
easYview #1 - #10 (Master)	Yes	-

Table 6:

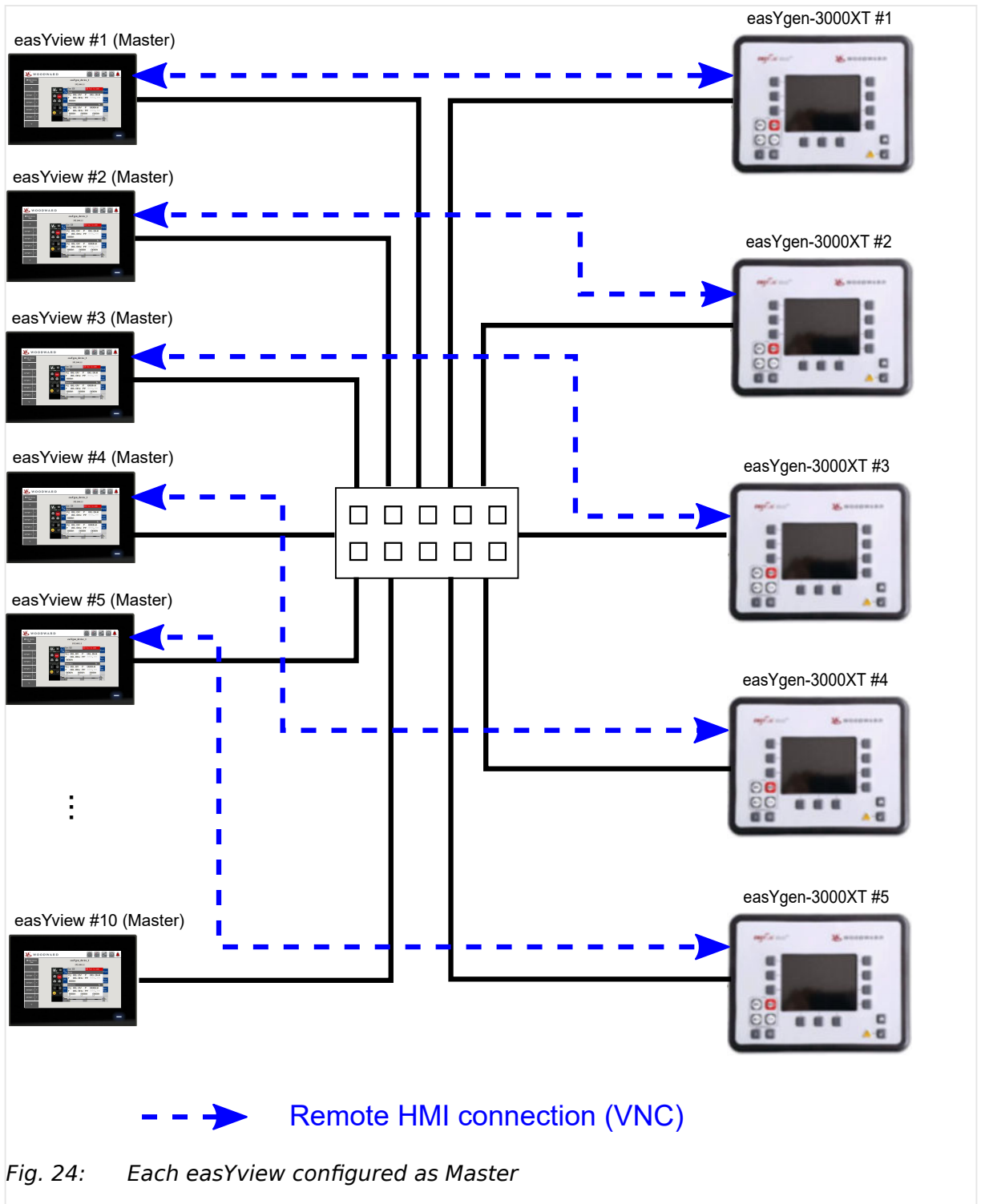

3 Installation

3.2.5.2.2 Cascading feature

Using the cascading feature

In the cascading feature, it is possible to configure one easYview as Master and all others as slaves. Therefore, the Master easYview is responsible to create active Remote HMI connections. The Slave easYview devices will send the request for a Remote HMI connection to the Master which creates the connection and sends the Remote HMI screen to the Slave device.

If the Slave device requests a Remote HMI connection which the Master has already created, a duplicated Remote HMI screen is send to the Slave. Therefore multiple easYview devices can show the same Remote HMI screen.

easYview	Setting "Remote HMI" / "Use own IP"	IP address (of Master easYview)
easYview #1 (Master)	Yes	-
easYview #2 - 10 (Slave)	No	IP address of easYview #1

Table 7:



The Remote HMI screen which is shown on the Master easYview can be different then the Remote HMI screen which is shown on a Slave easYview.

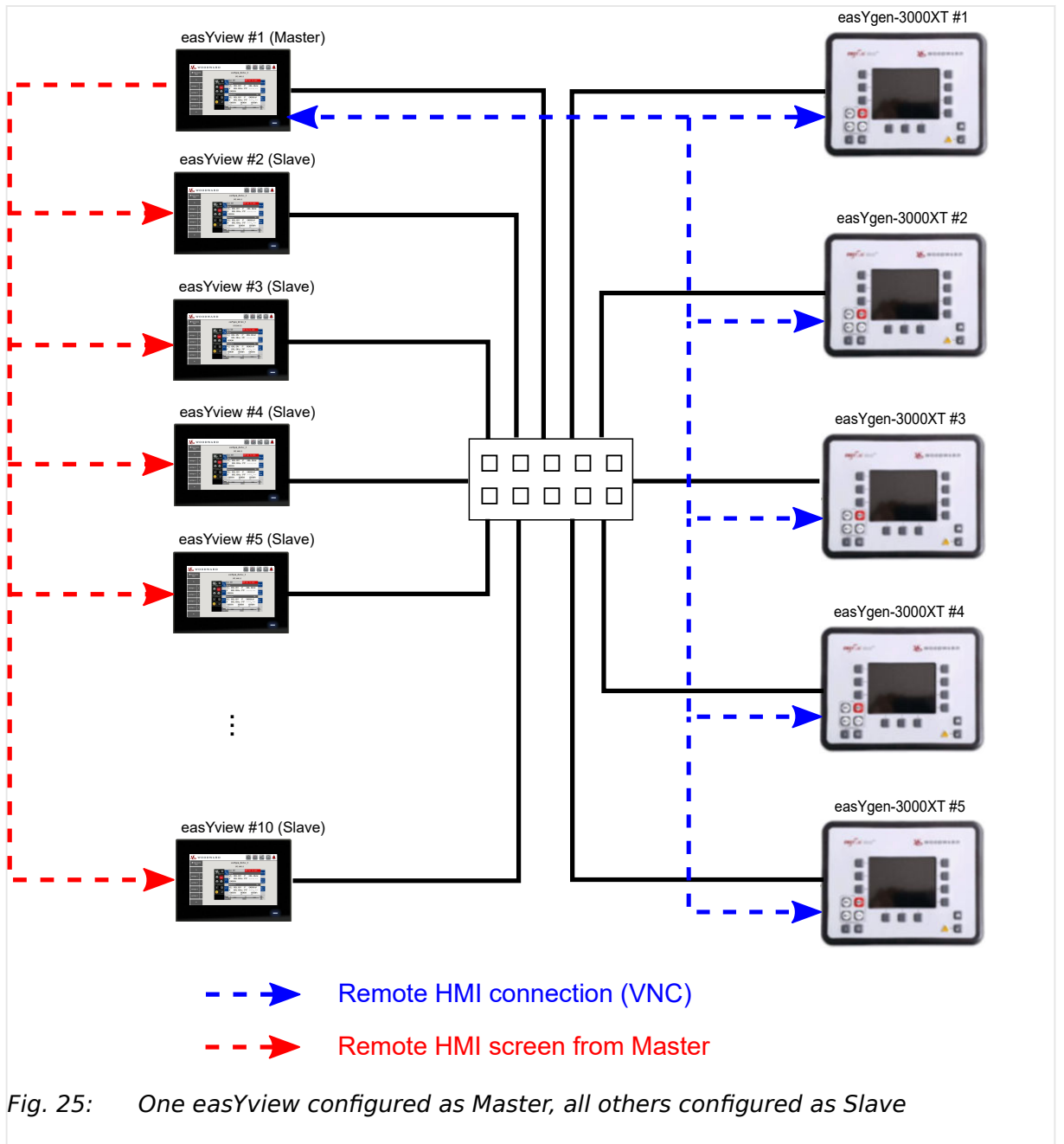

Operating on a Remote HMI screen will also change all other Remote HMI screens of the same connection as well the HMI of the connected easYgen-XT or LS6-XT device.

4 Configuration

The easYview needs to be configured properly to communicate with the used devices in the system.

Also, it has to be configured to one of the two application modes: a Remote HMI mode or a mini-SCADA mode, refer to [↳ “2 System Overview”](#).

In this chapter all configurations that has to be done are described in detail.

4.1 First time Setup

If using the easYview the first time, the device has to be configured to work properly in the used system.



Before doing the first setup. We recommend the following pre-conditions of the system.

- Connect the easYview to an appropriate network via LAN A.
- Connect all other devices (easYgen-3000XT, LS6-XT, etc.) which shall communicate with the easYview to the same network.
- Boot up all devices (easYgen-3000XT, LS6-XT, etc.) on the network.
- Configure the desired IP addresses of the connected devices (easYgen-3000XT, LS6-XT, etc.).

After boot up, the easYview starts the mini-SCADA mode, see [↳ Fig. 26](#).

The mini-SCADA mode is the default application mode of the easYview.

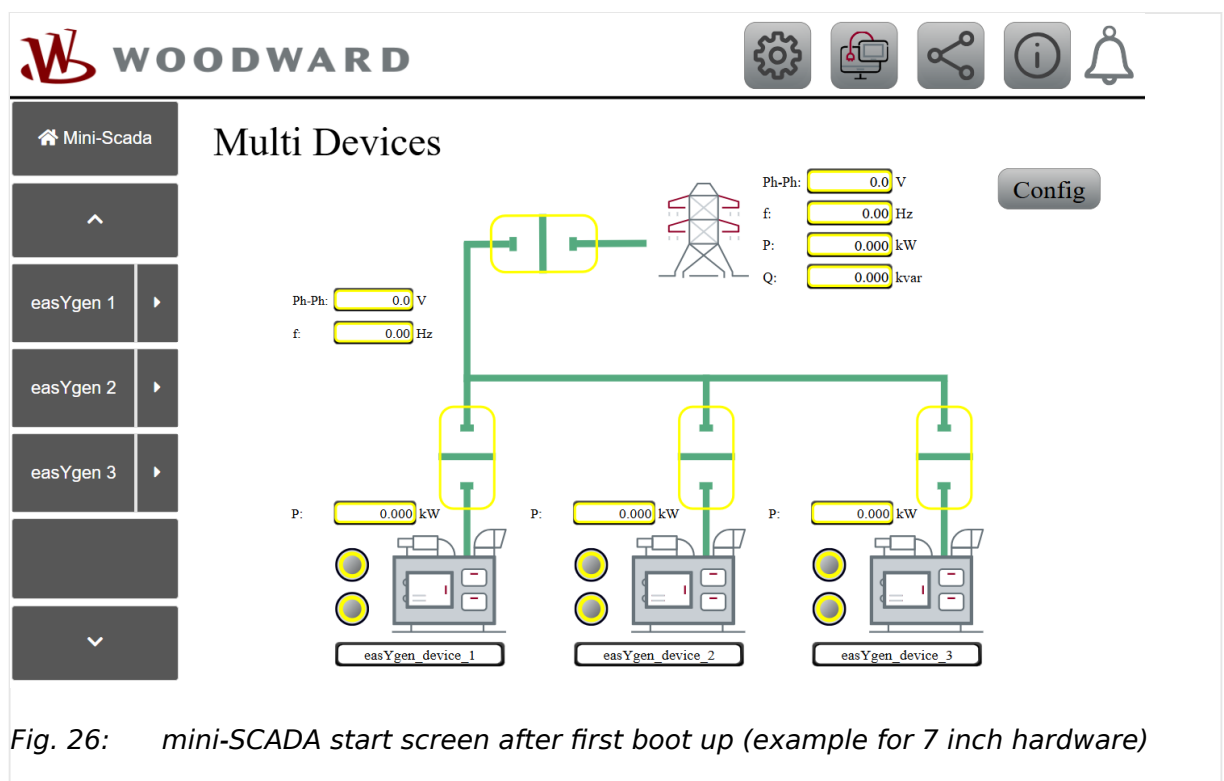

Fig. 26: mini-SCADA start screen after first boot up (example for 7 inch hardware)

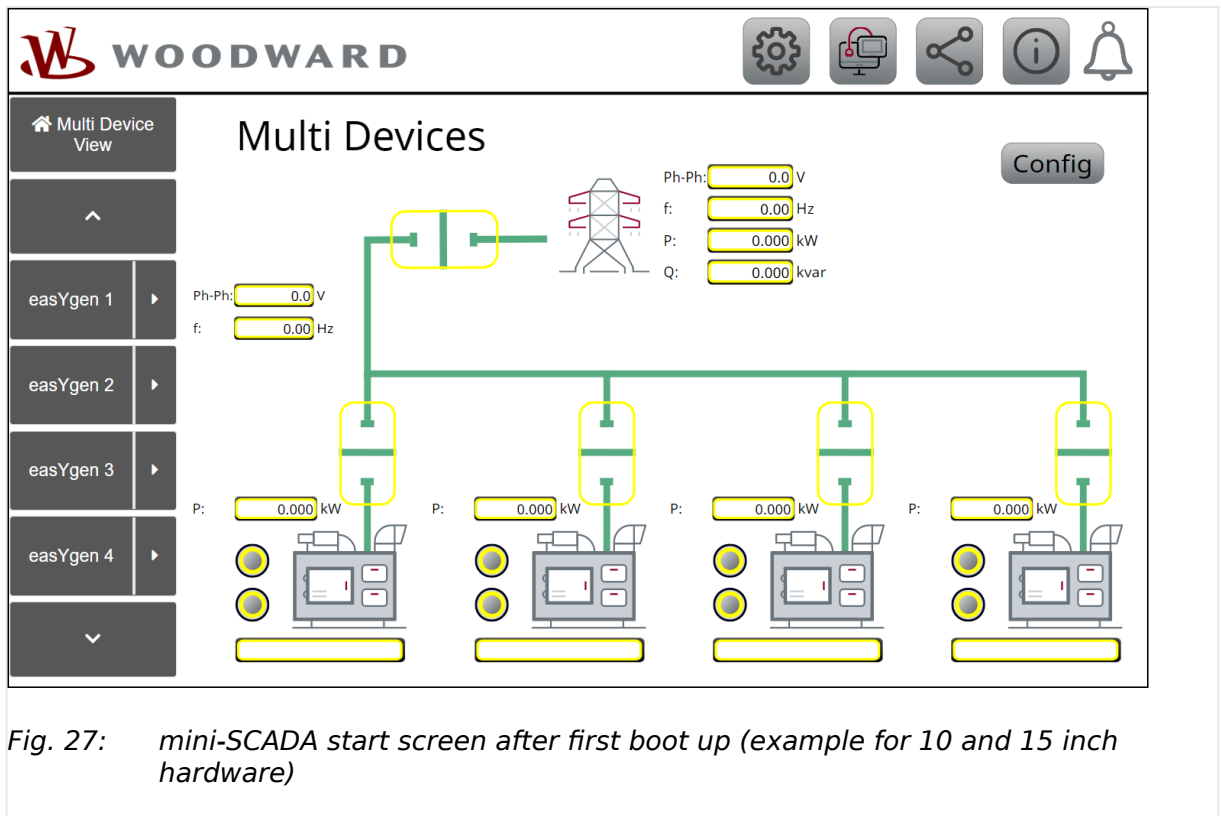

Fig. 27: mini-SCADA start screen after first boot up (example for 10 and 15 inch hardware)



Before the easYview is configured properly all values are flashing yellow because the connections are not established yet.

Follow these instructions to setup the easYview properly:

- General configuration: [↳ “4.2 General configuration”](#)
- Application configuration (only needed for mini-SCADA mode): [↳ “4.3 Application Configuration”](#)
- Password configuration: [↳ “4.4 Password configuration”](#)

After all configurations are done, refer to [↳ “5 Operation”](#) for further information how to use the easYview.

4.2 General configuration

General configurations of the easYview are:

- 1 Network settings (IP Address / Subnet Mask / Gateway / DNS server)
- 2 IP address for Remote HMI (Master/Slave)
- 3 Brightness of the display
- 4 Set-up the Application mode (mini-SCADA or Remote HMI)
- 5 Set-up the Auto connection mode (only if using Remote HMI mode)
- 6 Apply settings

4 Configuration

4.2 General configuration

To start with the general configurations open the settings page by clicking the settings page button.

In "mini-SCADA" mode: The settings page button is located on top of the each screen 

In "Remote HMI" mode: The settings page button is located on the left navigation bar.

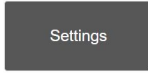

The settings page with the different areas is shown below.

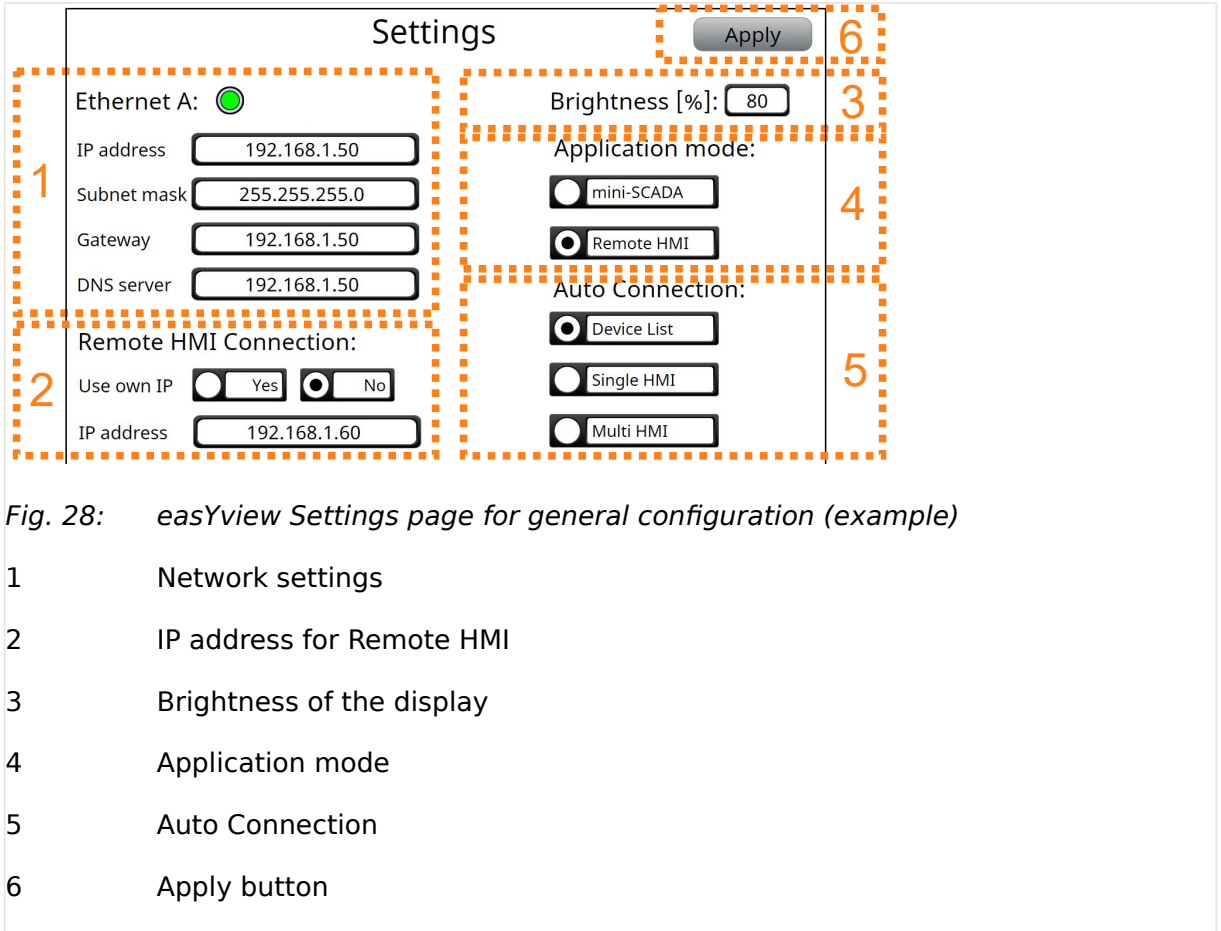

Fig. 28: easYview Settings page for general configuration (example)

- | | |
|---|---------------------------|
| 1 | Network settings |
| 2 | IP address for Remote HMI |
| 3 | Brightness of the display |
| 4 | Application mode |
| 5 | Auto Connection |
| 6 | Apply button |

Network settings (area 1)

The easYview must be in the same network as the devices for remote control. Therefore, it has to be configured for the same subnet mask and an IP address of this network. The IP address must be different from any other used in this address range.

Changing the network settings:

- Select the IP address field and change the value by using the pop-up key pad.
- Select the Subnet mask field and change the Subnet Mask by using the pop-up key pad.
- Select the Gateway field and change the value by using the pop-up key pad.
- Select the DNS server field and change the value by using the pop-up key pad.

CAUTION!**Avoid using the same IP address twice!**

By mistake it is possible to assign the same IP address for the easYview as configured for the easYgen-3000XT or LS-6.

In this case the last configured device (easYview) will work properly but the so far configured device (easYgen-3000XT) will be invisible on the Ethernet: **Load Share and ToolKit do not work on this device!** ... and cannot be found for remote connection.

Solution:

- Apply again properly IP addresses for these devices
- or
- reset easYgen-3000XT (power cycle)

Network mismatch using the same IP address twice with other devices can be handled similarly.

NOTICE!

If the IP address of the easYview has changed, the connections to the configured easYgens are not valid anymore (if already configured). A reboot from the [↳ "4.3 Application Configuration"](#) page is required.

Missing Ethernet settings

If the easYview device has booted without connected Ethernet cable, the Ethernet port is disabled so no Ethernet settings are shown and the Ethernet A lamp is grey:

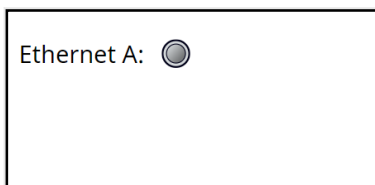

Fig. 29: Settings page - Unplugged ethernet connection lamp gray

Please plug in the Ethernet cable and click on the Woodward Logo in the left upper corner to refresh the screen. Maybe it is needed to repeat the refresh because the Ethernet port activation needs a few seconds.

After a successful refresh the Ethernet A lamp is green and the network settings are shown, see [↳ Fig. 28](#). The operator is now able to change the network setting of the easYview (IP address, for instance).

IP address for Remote HMI (area 2):

Only one easYview panel can establish a connection via Remote HMI to an easYgen-3000XT or LS6-XT. Nevertheless, the easYview offers the possibility for a cascade-like set-up of two (or more) easYview panels. One easYview panel is connected to the easYgen, more easYview panels are in the same network.

4 Configuration

4.2 General configuration

To make a connection with several easYview to the same easYgen-3000XT, the setting "Remote HMI" / "Use own IP" has to be set to "No". Then the IP address of the easYview (Master) that has the Remote HMI connection to the easYgen-3000XT has to be defined, for more information refer to [3.2.5.2 Remote HMI \(VNC\) Topology](#)

Use own IP address for Remote HMI: "Yes"

The own easYview panel has a direct Remote HMI connection to the easYgen-3000XT.

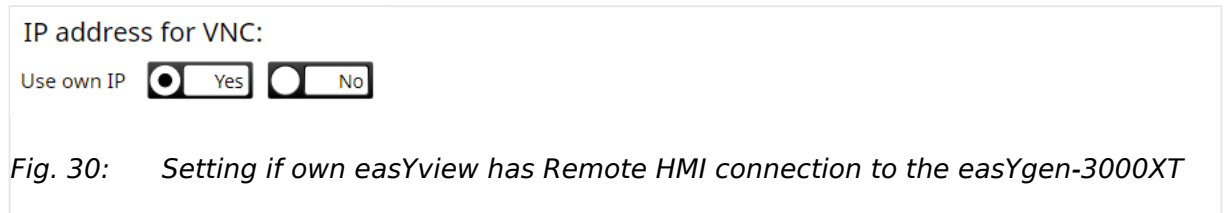

IP address for VNC:

Use own IP Yes No

Fig. 30: Setting if own easYview has Remote HMI connection to the easYgen-3000XT

Use own IP address for Remote HMI: "No"

This easYview is in the same network as another easYview which has direct Remote HMI connection to the easYgen-3000XT.

Define the IP address of the other easYview.

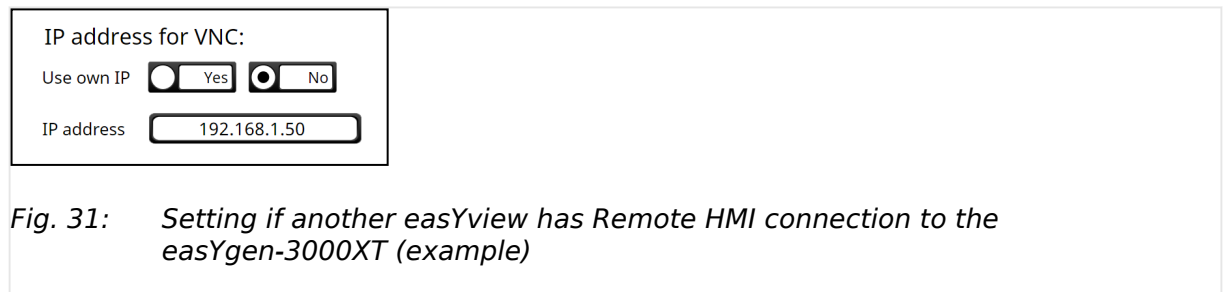

IP address for VNC:

Use own IP Yes No

IP address

Fig. 31: Setting if another easYview has Remote HMI connection to the easYgen-3000XT (example)

Brightness (area 3):

The brightness of the display can be adjusted from 1 to 100%.

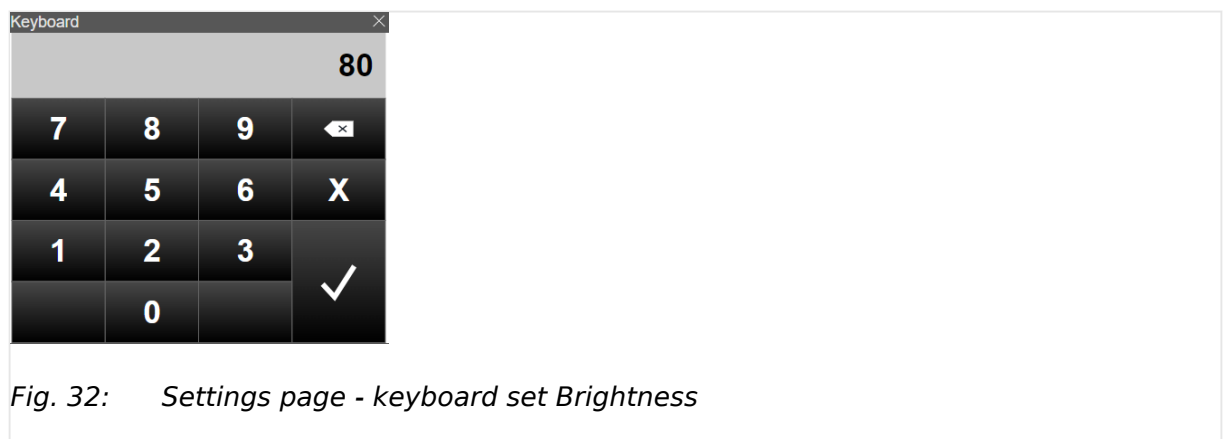

Keyboard

80

7	8	9	←
4	5	6	X
1	2	3	✓
	0		

Fig. 32: Settings page - keyboard set Brightness

A brightness change comes into effect after clicking the "Apply" button.

Application mode (area 4):

The application mode defines if the easYview starts in mini-SCADA or in Remote HMI mode. By default, the application mode mini-SCADA is selected. For more information about the Application modes refer to [5.2 mini-SCADA mode](#) and [5.1 Remote HMI mode](#).

Application mode:

mini-SCADA

Remote HMI

Fig. 33: Settings page - Application mode

If Remote HMI mode is selected, the Auto Connection appears and can be configured, see area 5.

Auto Connection (area 5):

The Auto Connection defines the start page for the Remote HMI mode. After each boot up or browser refresh (Click on Woodward Logo) the selected page shows up.

Application mode:

mini-SCADA

Remote HMI

Auto Connection:

Device List

Single HMI

Multi HMI

Fig. 34: Settings page - Auto Connection

Auto Connection settings:

- Device List: Shows all available devices on the same network like the easYview it self.
- Single HMI: Shows the Single HMI page with the last connection which was selected for Single HMI.
- Multi HMI: Shows the Multi HMI page with the last connections which were selected for Multi HMI.



Note: The Auto Connection Multi HMI is only available for devices with display size 10' or 15'.

Apply button (area 6):

To save the settings (area 1-5) click the Apply button, otherwise the changes will be discarded. A pop-up dialog is opened to confirm the settings change.

4 Configuration

4.3 Application Configuration

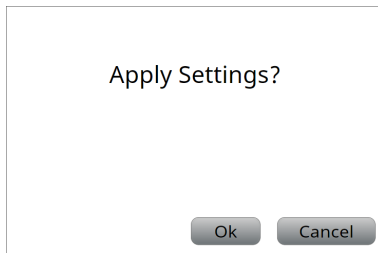

After clicking the Ok button all changes will be saved. The time needed for this is shown in a count down screen.

Saving settings, please wait...



4.3 Application Configuration

Depending on the application mode there are additional configurations to consider.

How to switch between the application modes, refer to [↪ "4.3.3 Change application mode"](#).

4.3.1 Setup Remote HMI mode

The Remote HMI mode has no additional settings other than described in [↪ "4.2 General configuration"](#)

For further information how to use this mode, refer to [↪ "5.1 Remote HMI mode"](#)

4.3.2 Setup mini-SCADA mode

In the mini-SCADA mode there are some additional settings to adjust.

Precondition:

- Set Modbus protocol of all connected easYgen-3000XT devices to 5016 (parameter ID 3184).
- Check up the Modbus Slave ID of all connected easYgen-3000XT devices (parameter ID 3188) and keep them in mind.

There is no rule how the Modbus Slave IDs have to be set-up and they also can all be the same. But they have to be known for further configuration.

Connection overview page

Open the Connection Settings page by clicking the 'Connection' button  on the top of each easYview screen.

From the connection overview page navigate to easYgen-3000XT or LS6-XT connection page and adjust the settings accordingly.

To apply the adjusted settings, a reboot has to be triggered from the connection overview page.

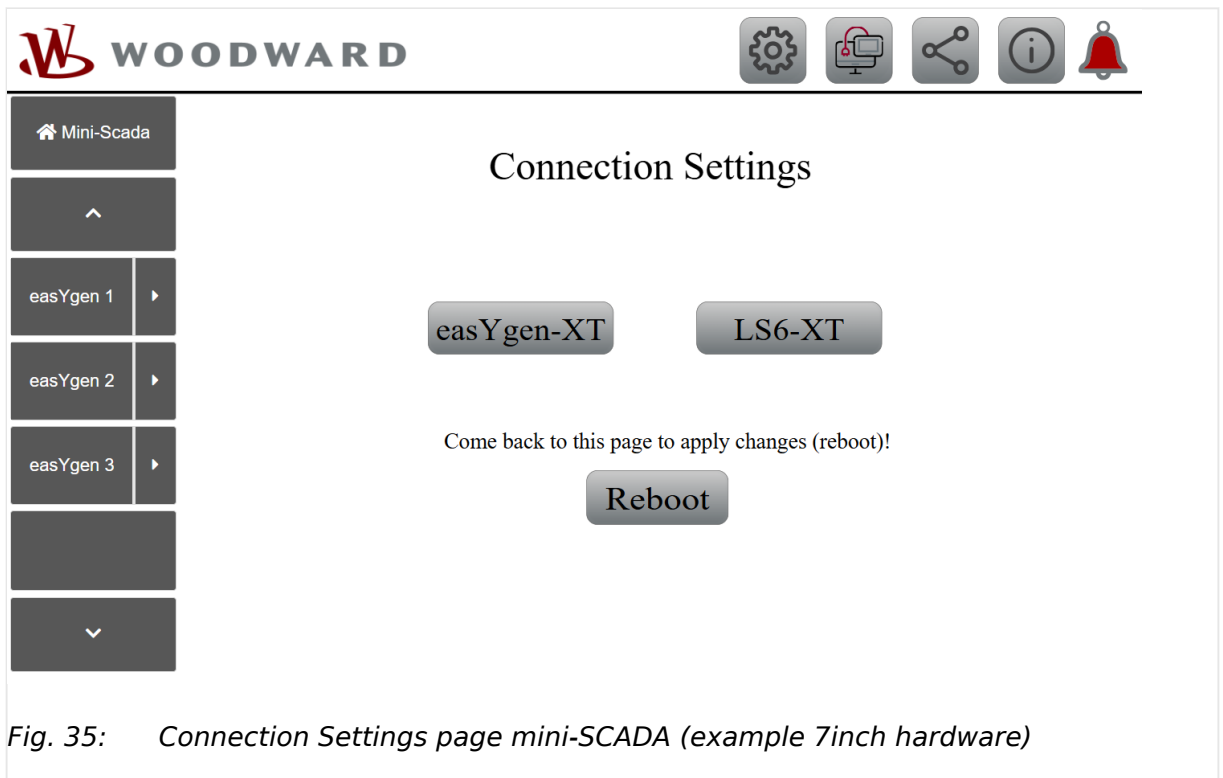

Fig. 35: Connection Settings page mini-SCADA (example 7inch hardware)

The easYview has this predefined connections available.

- 3 easYgen-XT and 3 LS6-XT connections (7 inch hardware)
- 9 easYgen-XT and 9 LS6-XT connections (10 and 15 inch hardware)

The predefined connections has to be adjusted to match the settings of the easYgen-XT or LS6-XT devices which are used.



In the visualization of the easYview there is only a certain number of active connections, which receive values, supported.

- For 7 inch hardware: max 3 active connections
- For 10 and 15 inch hardware: max 18 active connections

The connections for easYgen-XT and LS6-XT can be mixed up, but in total only the maximum active connections can be used. The easYgen-XT 1-3 (7 inch hardware) or easYgen 1-4 (10/15 inch hardware) connections are active by default. All LS6-XT connections are prepared but disabled by default.

To enabled these connections and use them for the visualization, please refer to application note #37949 available at <http://www.woodward.com> or at the QR server <http://wwdmanuals.com/easyview>.

Connection page easYgen-XT

Press the **easYgen-XT** button from the connection overview page to change the easYgen-XT settings

4 Configuration

4.3.2 Setup mini-SCADA mode

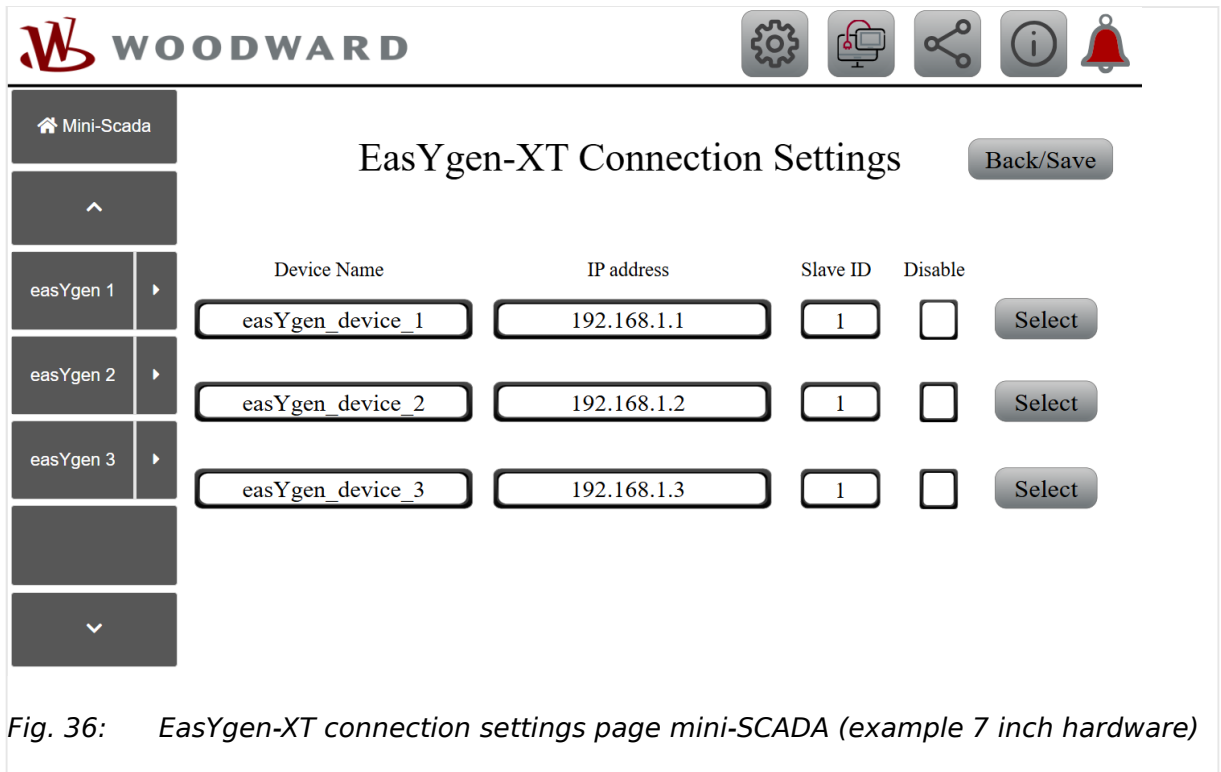

Fig. 36: EasYgen-XT connection settings page mini-SCADA (example 7 inch hardware)

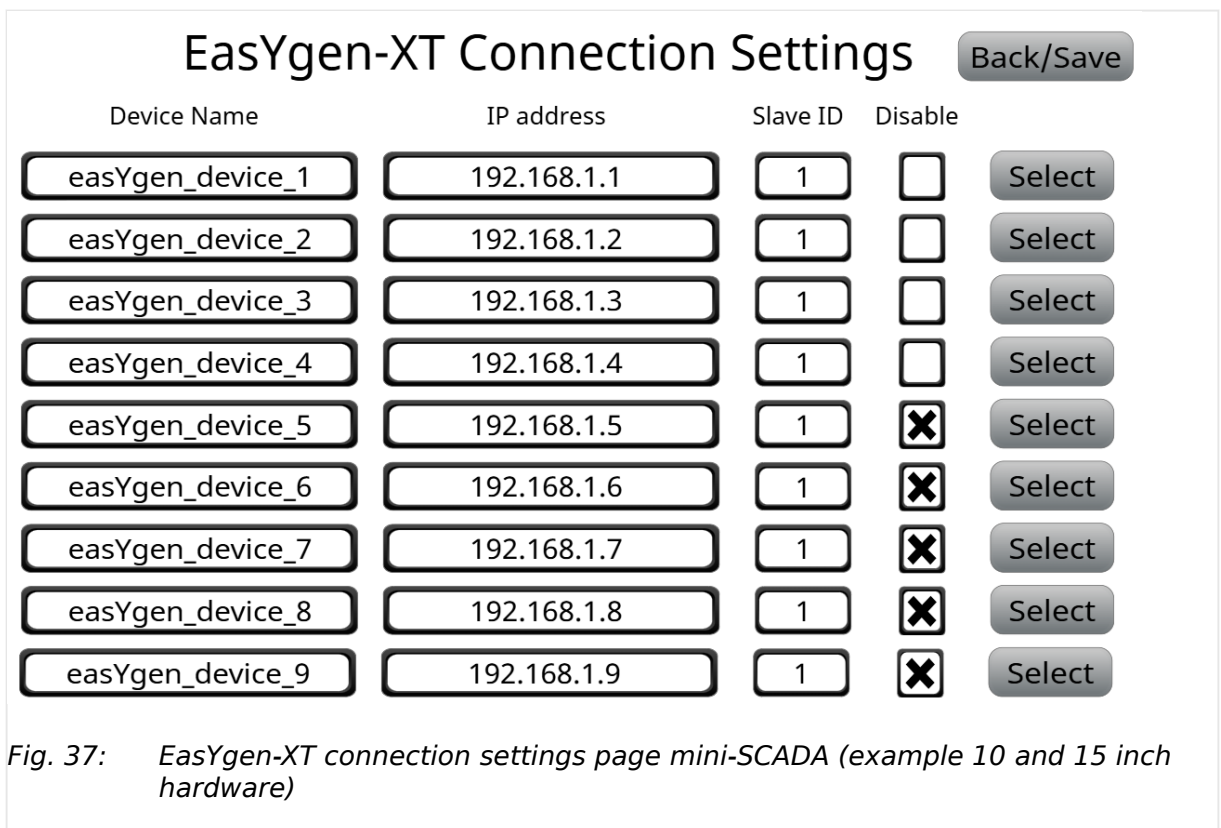

Fig. 37: EasYgen-XT connection settings page mini-SCADA (example 10 and 15 inch hardware)

Connection page LS6-XT

Press the  button from the connection overview page to change the LS6-XT settings

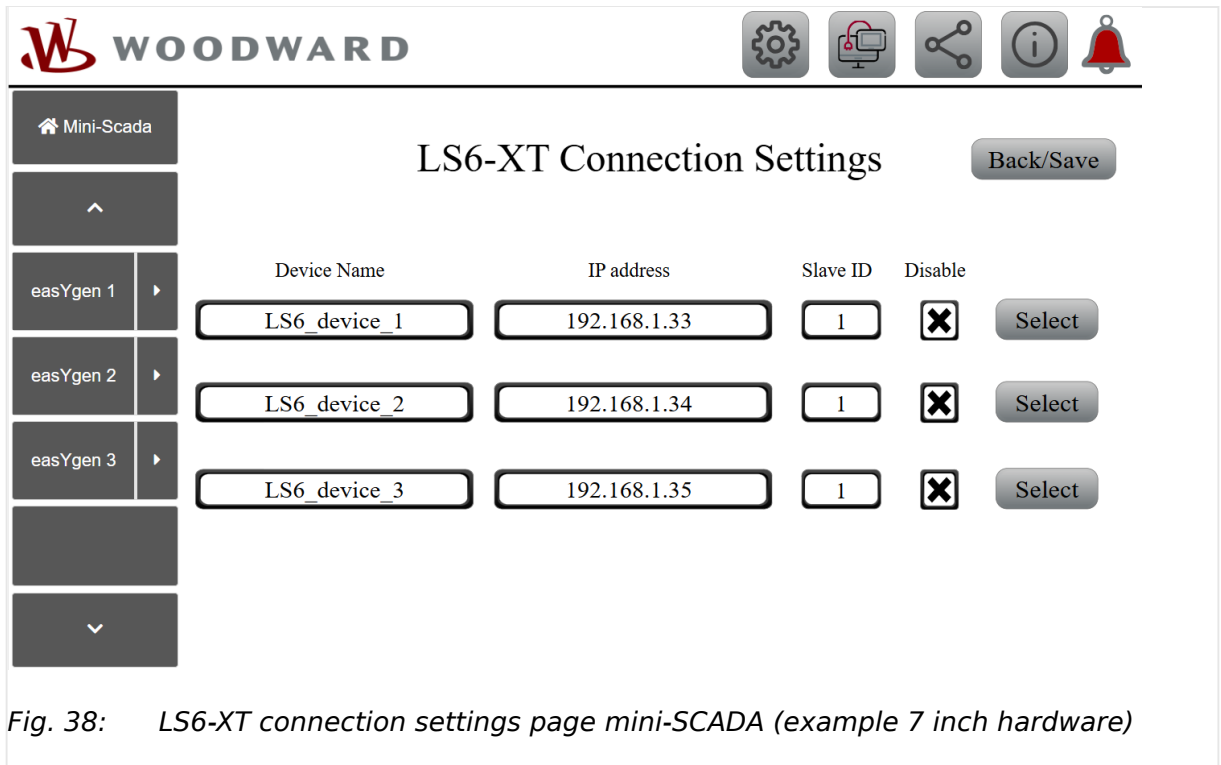

Fig. 38: LS6-XT connection settings page mini-SCADA (example 7 inch hardware)

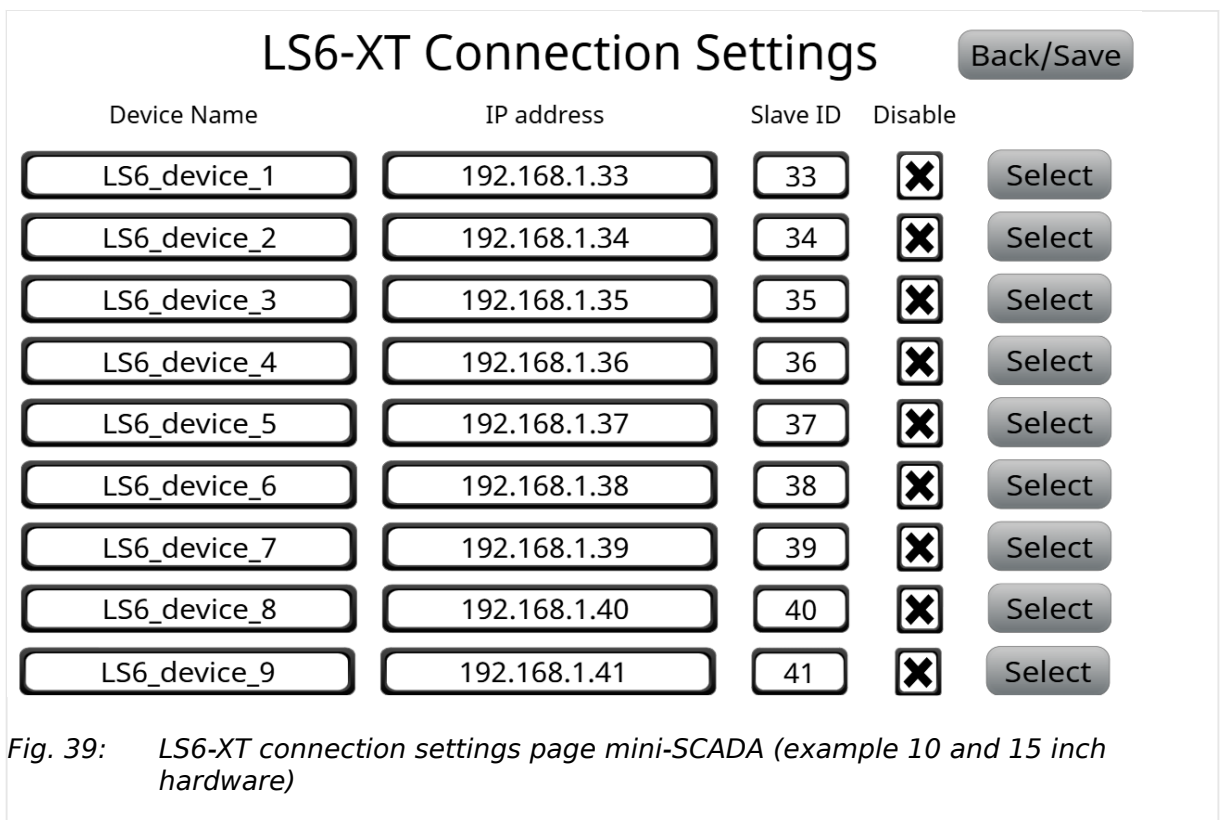

Fig. 39: LS6-XT connection settings page mini-SCADA (example 10 and 15 inch hardware)

Changed values

If a value has changed on a connection page, the changed fields are marked with yellow color.

Those fields will remain marked as changed (yellow) until either a reboot was triggered to apply the changes or a browser refresh (Click on Woodward Logo) is triggered. A browser

4 Configuration

4.3.2 Setup mini-SCADA mode

refresh (without a reboot before) will discard all changes back to the previous saved values.

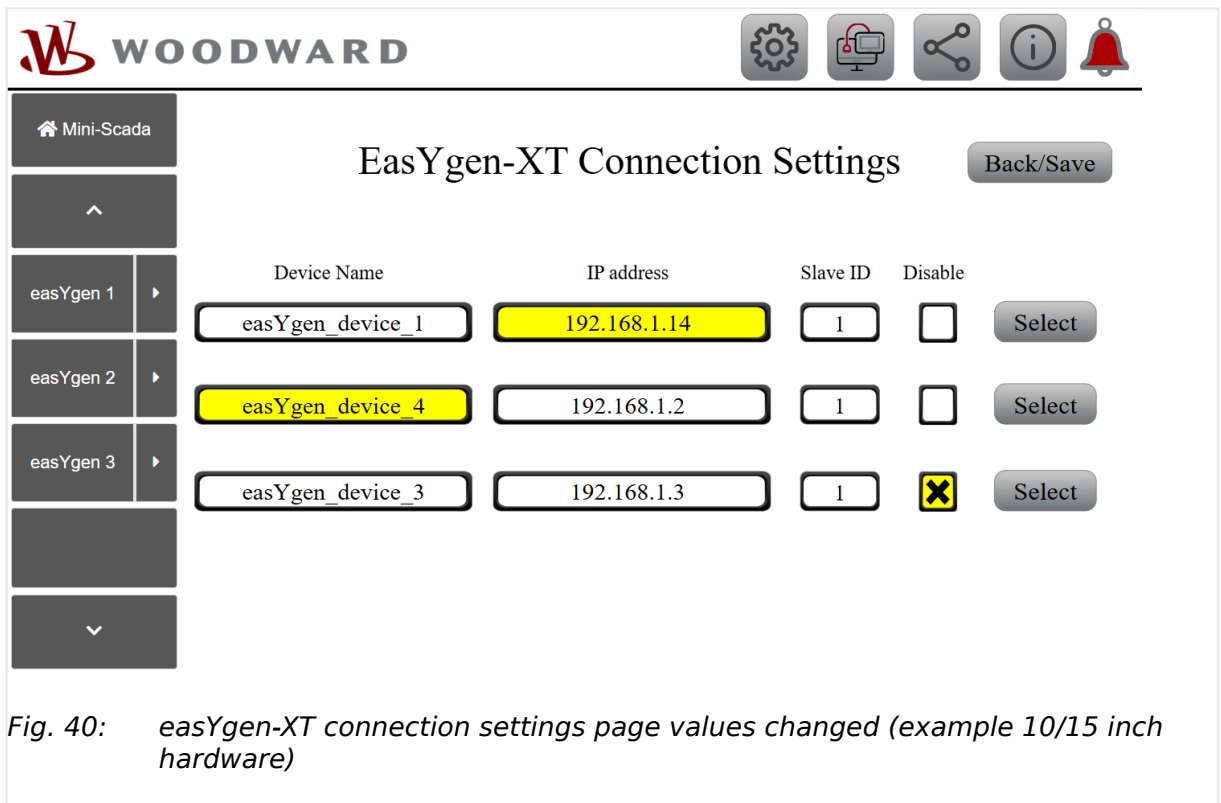

Connection settings

The following list shows the available settings for each connection:

- Name: Defines the name of the connected easYgen-3000XT/LS6-XT devices. The names of easYgen-XT devices are shown on the according easYgen-XT home page, on the Multi Device page and on the remote HMI page.
- IP address: The IP address is used to establish a Modbus TCP connection to the according device. Additional it is used to request the according Remote HMI screen from the easYgen-XT home page. The IP address will be shown on the remote HMI page.
- Slave ID: The Modbus Slave ID has to match with the connected device to establish the Modbus TCP connection.
- Disable: If disabled, the Modbus TCP connection is disabled. For connections of easYgen-XT devices, all related device information will be hidden from the visualization (Multi Device page, navigation etc).
- The 'Select' button leads to a device list that shows all available devices in the same network as the easYview. Selecting a device from the list will override the according name and IP address and mark them as changed (yellow) until the Back/Save button is pressed followed by a reboot from the ["Connection overview page"](#)

Define name and IP address of connected devices

The name and IP address can be changed in two ways:

- Manually entered over keyboard pop up window.
- Selecting a device from the network (device list).

Entering the name and IP address manually:

- Select the name field and enter the desired name with the keyboard window that pops up.



Fig. 41: Connection settings - keyboard set name

- Select the IP address field and enter the IP address with the keyboard window that pops up.

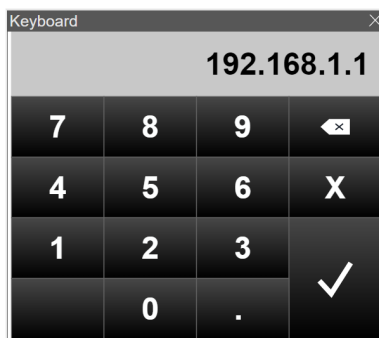

Fig. 42: Connection settings - keyboard set IP address

Selecting a device from the network:

- The 'Select' button opens a list view that shows all available devices in the same network as the easYview. Select a device and press the "Ok" Button. The name and the IP address will be overwritten with the selected one.

4 Configuration

4.3.2 Setup mini-SCADA mode

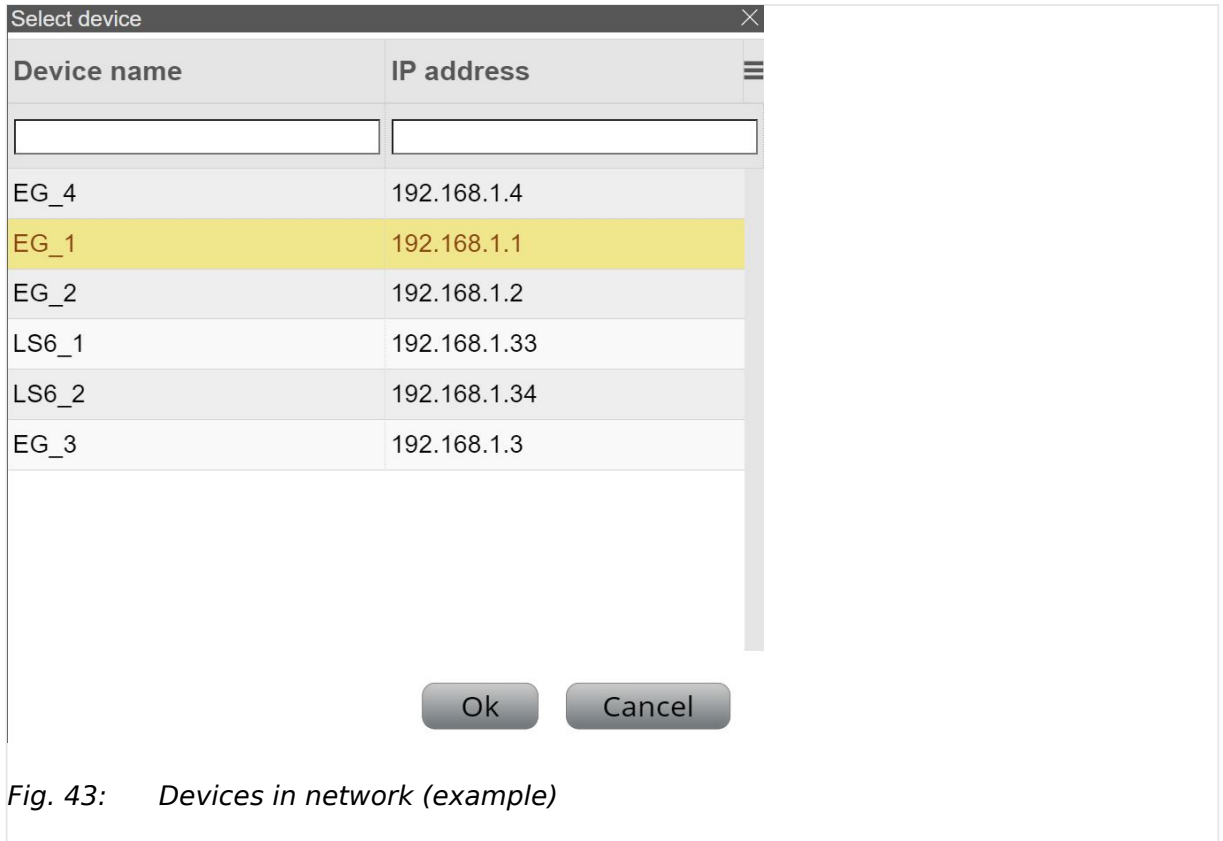

Fig. 43: Devices in network (example)



The device list view is loaded only once. It will not be updated while it is open. To refresh the device list, close it and re-open it.

In the device list view it is possible to use different sorting and search options to find the desired device.

Sorting:

Selecting a column header (name or IP address) in the list view. This will activate the sorting of the available devices. Selecting the name header will sort by name, selecting the IP address header will sort by IP address. The sorting is alphabetically (also the IP address) and can be switch between ascending (0 to 9, A to Z) and descending (9 to 0, Z to A) sorting.

Select device	
Device name	IP address
<input type="text"/>	<input type="text"/>
EG_1	192.168.1.1
EG_2	192.168.1.2
EG_3	192.168.1.3
EG_4	192.168.1.4
LS6_1	192.168.1.33
LS6_2	192.168.1.34

Fig. 44: Devices in network (example sorting)

Search (filter):

To use the build in text search filter, select the search input fields and use the keyboard pop up window for text inputs. The search filter option is case insensitive. The wild card character (*) can be used as placeholder, regular expressions are not supported. The search applies direct after accepting the text input from the keyboard pop up ("EN"). None matching results will be filter out, so only the matching results will be shown in the list.

Select device	
Device name	IP address
<input type="text" value="eg"/>	<input type="text"/>
EG_4	192.168.1.4
EG_1	192.168.1.1
EG_2	192.168.1.2
EG_3	192.168.1.3

Fig. 45: Devices in network (example search filter)

Over the burger icon in the right upper corner the search filter can be reset and the search input fields can be disabled (hidden) if not needed.

4 Configuration

4.3.2 Setup mini-SCADA mode

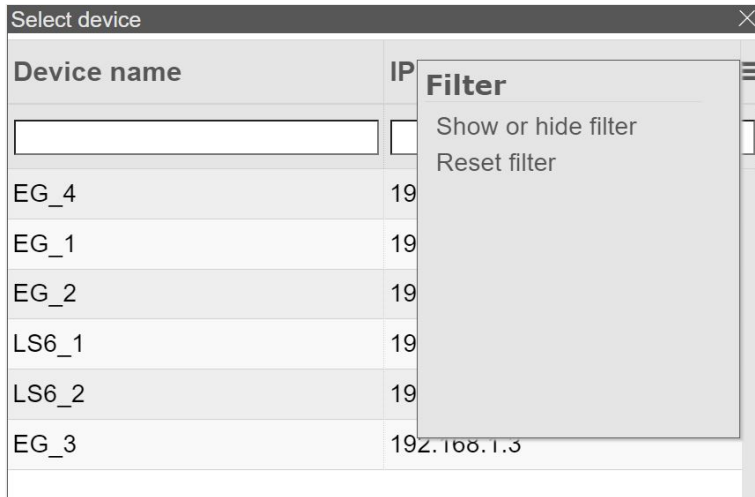

Fig. 46: Devices in network (example search filter menu)

Configure the Modbus Slave ID

By selecting the Modbus Slave ID field a keyboard pops up where the appropriate Modbus Slave ID can be entered.

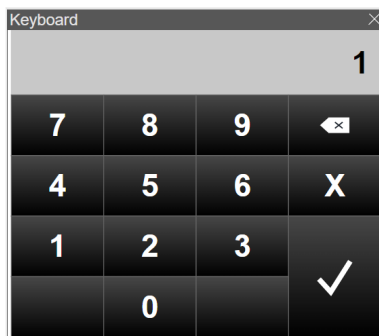

Fig. 47: Connection settings - keyboard set Modbus Slave ID



Wrong Slave ID

The Slave ID is only used in the mini-SCADA mode. If the connected device has wrong Slave ID it still can receive the Remote HMI screen.

Disable/Enable devices

With the Disable checkbox each single device can be disabled (checked) or enabled (unchecked).

If a device is disabled, all related parts which exist in the visualization will be hidden. By default only easYgen connection 1-3 are available in the visualization. For all disabled connections (even if not used in the visualization) no Modbus data is requested from the according device.

Reboot

The device has to be rebooted to adopt the settings. Navigate back to the Connection overview page **Back/Save** and Reboot **Reboot** the easYview device. Without reboot the changed values won't have any effect. For more information about the changed values, refer to [↩️ "Changed values"](#).

Before the device reboots an extra confirmation dialog pops up.

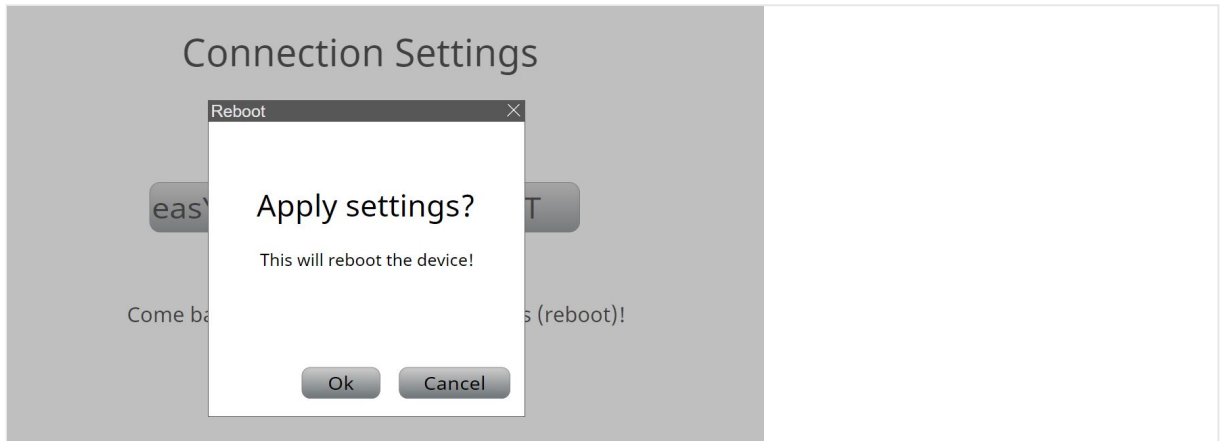

Fig. 48: Connection settings - reboot confirmation

While the device reboots the following message is shown

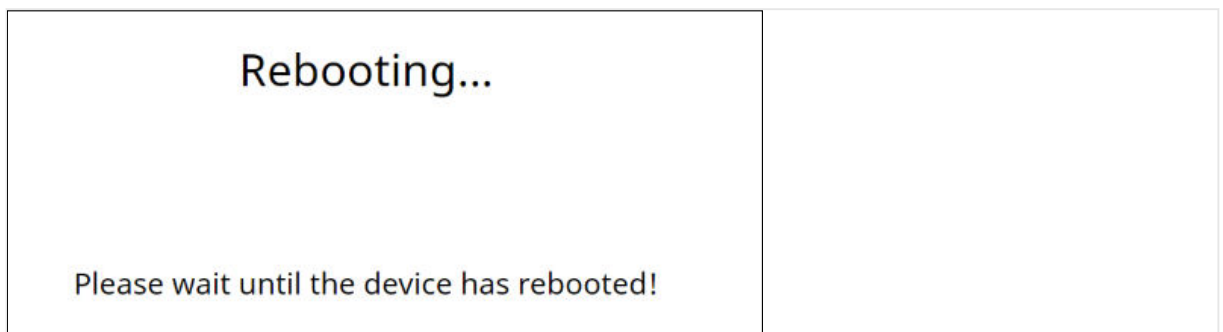

Fig. 49: Rebooting



It is recommended not to click any button during reboot to avoid unexpected behaviour.



If the reboot is initiated from the Remote panel or from a browser on a PC, all open browsers (PC) should be closed during the reboot. Otherwise the message 'CCD exceeded!' could pop-up.

4 Configuration

4.3.3 Change application mode

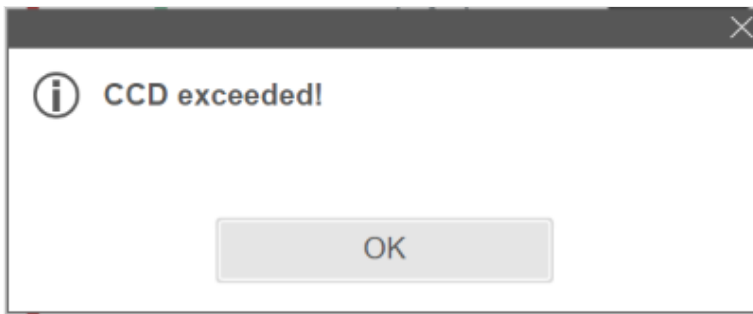

Fig. 50: CCD exceeded

NOTICE!



If the IP address of the easYview has changed, the connections to the configured easYgens are not valid anymore (if already configured). A reboot from this page is required.

Blinking field

If one or more values or fields are blinking yellow the connection to the easYgen-3000XT is not established. Please check the connection and the settings.

For further information how to use the mini-SCADA mode, refer to [↳ "5.2 mini-SCADA mode"](#)

4.3.3 Change application mode

The application mode of the easYview can be changed easily between mini-SCADA visualization and Remote HMI mode.

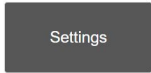
- In the min-SCADA mode push the icon  on top visualization screen. In the Remote HMI mode push the button  on left navigation bar.
- In the settings page, select the desired application mode, refer to [↳ "Application mode \(area 4\)":"](#).
- Press 'Apply Changes'.

4.4 Password configuration

Some areas in the file system of the easYview can be accessed by SFTP client. In this areas there are project related files which may need to be modified or exchanged. This only applies to users which want to modify the existing mini-SCADA visualization.

For more information refer to application note #37949 available at <http://www.woodward.com> or at the QR server <http://wwdmanuals.com/easyview>.

To prevent unintended changes, the SFTP access is protected by a default password. The default user name is "user" and the default password is "user".

NOTICE!**Change default password**

We **strongly** recommend all customers to change the default password to protect the easYview against unintended changes.

The password can be changed as follows:

Procedure to change default password by using ssh client functions (included in Windows 10):

- Open the Windows Console
- Establish a ssh connection:
 - Enter the command 'ssh user@<ip-address>' (replace <ip-address> by the IP address of the easYview)
 - Enter the default password 'user'

```

CAL user@tpc71wn10pa: ~
usage: ssh [-46AaCfGgKkMnNqsTtVvXxYy] [-B bind_interface]
          [-b bind_address] [-c cipher_spec] [-D [bind_address:]port]
          [-E log_file] [-e escape_char] [-F configfile] [-I pkcs11]
          [-i identity_file] [-J [user@]host[:port]] [-L address]
          [-l login_name] [-m mac_spec] [-O ctl_cmd] [-o option] [-p port]
          [-Q query_option] [-R address] [-S ctl_path] [-W host:port]
          [-w local_tun[:remote_tun]] destination [command]

C:\>ssh user@192.168.0.50
user@192.168.0.50's password:
Welcome to Ubuntu 16.04.6 LTS (GNU/Linux 4.1.15 armv7l)

 * Documentation:  https://help.ubuntu.com
 * Management:    https://landscape.canonical.com
 * Support:       https://ubuntu.com/advantage

0 packages can be updated.
0 updates are security updates.

The programs included with the Ubuntu system are free software;
the exact distribution terms for each program are described in the
individual files in /usr/share/doc/*/copyright.

Ubuntu comes with ABSOLUTELY NO WARRANTY, to the extent permitted by
applicable law.

-bash: /proc/1913/enviro: Permission denied
user@tpc71wn10pa:~$
  
```

Fig. 51: ssh window (example)

**Store password**

There is no possibility to reset the password. We strongly recommend to store the new password, otherwise the device has to be send back for repair!

4 Configuration

4.4 Password configuration

- Change the password:
 - At the prompt `user@tcp71wn10pa:~$` enter 'passwd'
 - Follow the instructions:
 - enter the current UNIX password
 - enter the new UNIX password (the password must have minimum 8 signs)
 - retype the new UNIX password

After successful change the following text is shown: 'passwd: password updated successfully'.

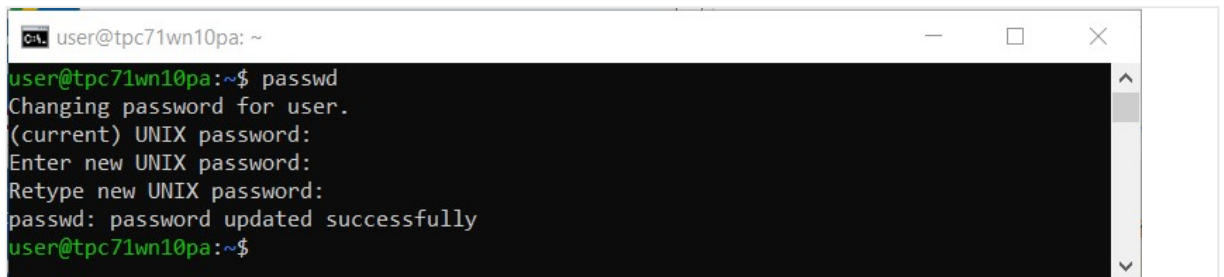
A screenshot of a terminal window titled 'user@tcp71wn10pa: ~'. The terminal shows the following text:

```
user@tcp71wn10pa:~$ passwd
Changing password for user.
(current) UNIX password:
Enter new UNIX password:
Retype new UNIX password:
passwd: password updated successfully
user@tcp71wn10pa:~$
```

Fig. 52: *ssh window after successful password change (example)*

5 Operation

General notes

DANGER!



Please be aware that the remote settings and requests are transferred immediately to the genset - there is no prepare-before-send step in between!

The easYview has two basic application modes: a Remote HMI mode and a mini-SCADA mode.

- In Remote HMI mode the easYview connects to one or more devices via VNC technology and receives the Remote HMI screen of the connected easYgen-XT or LS6-XT device
- In mini-SCADA mode the easYview connects to up to three devices (for 7 inch hardware) or up to 18 devices (for 10/15 inch hardware) via Modbus TCP connection at a time and offers a plant visualization.

Each data variable that gets displayed in the visualization needs one connection (called CCD) to the server. In mini-SCADA mode the visualization can be opened in a second browser in parallel e.g. on a PC. The CCDs are counted for every active browser session, so if you connect to the visualization from two browsers on the same machine, both will count CCDs. The amount of CCDs are limited. To avoid too many connections to the server, reduce the number of unneeded browsers, by switching to the PC mode page or closing the browsers. The PC mode page keeps the number of needed CCDs as low as possible.

Maximum five easYview devices can be connected to one easYgen-3000XT.

5.1 Remote HMI mode

The main purpose of the Remote HMI mode is to show a duplicated Remote HMI screen of an easYgen-XT or LS6-XT device. Therefore a unique VNC connection to the easYgen-XT or LS6-XT device need to be established, refer to [↳ “5.1.2.1 Device List page”](#).

Depending on the screen size the easYview can show 1-4 different Remote HMI screens at the same time, refer to [↳ “5.1.2.2 Single Remote HMI page”](#) and [↳ “5.1.2.3 Multi Remote HMI page”](#). Through further configuration it is possible to cascade multiple easYview, refer [↳ “3.2.5.2.2 Cascading feature”](#)



To change the application mode of the easYview, refer to [↳ “4.2 General configuration”](#)



The easYview in Remote HMI mode has slightly different behavior depending on the display size (7, 10 or 15 inch)

The differences are described in the according sub-chapters.

Connecting via PC to an easYview has always the same behavior like an easYview with a 15inch display.

5 Operation

5.1.1 The Remote HMI visualization

5.1.1 The Remote HMI visualization

The Remote HMI screen offers three areas of information and communication/control:

- 1 At the top left there is the logo.
- 2 The left part of the screen is the navigation bar.
- 3 The right part of the screen is the content of the visualization pages. It is cyclically updated.

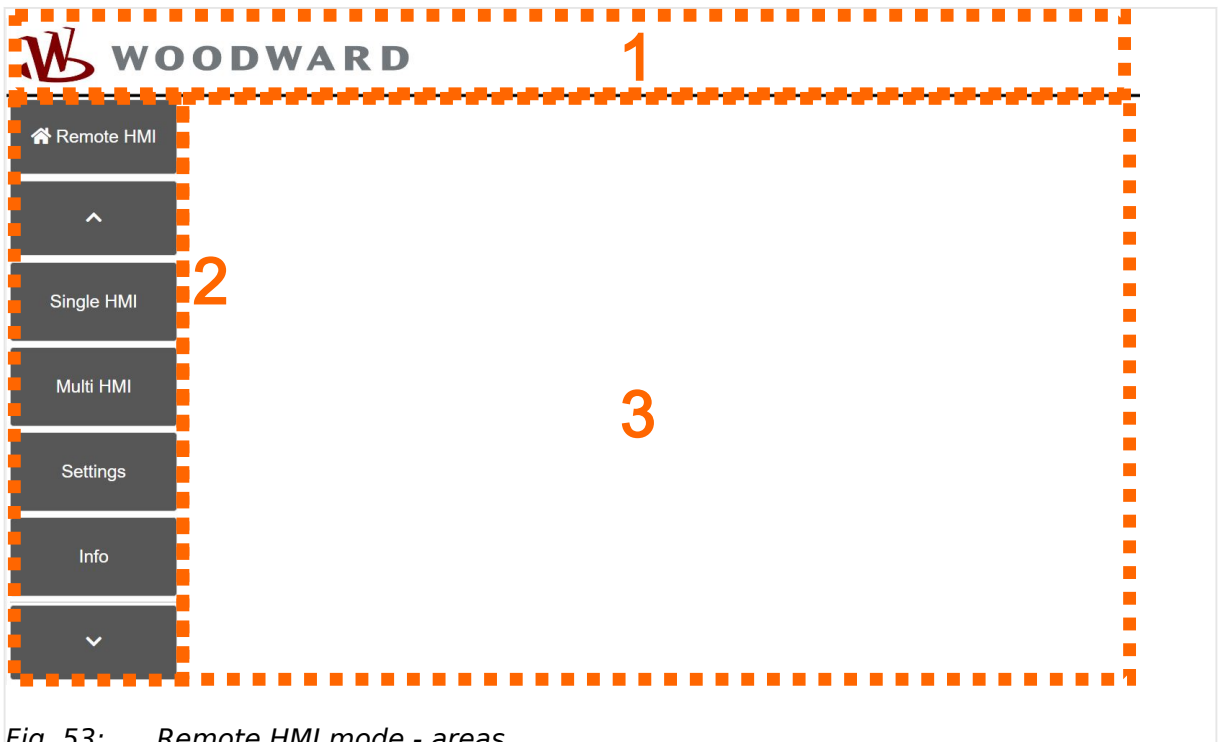

Fig. 53: Remote HMI mode - areas

- 1 Woodward Logo
- 2 Navigation bar
- 3 Content of the Remote HMI visualization pages

Navigation bar

The actual shown page is highlighted yellow, see [↪ Fig. 54](#).

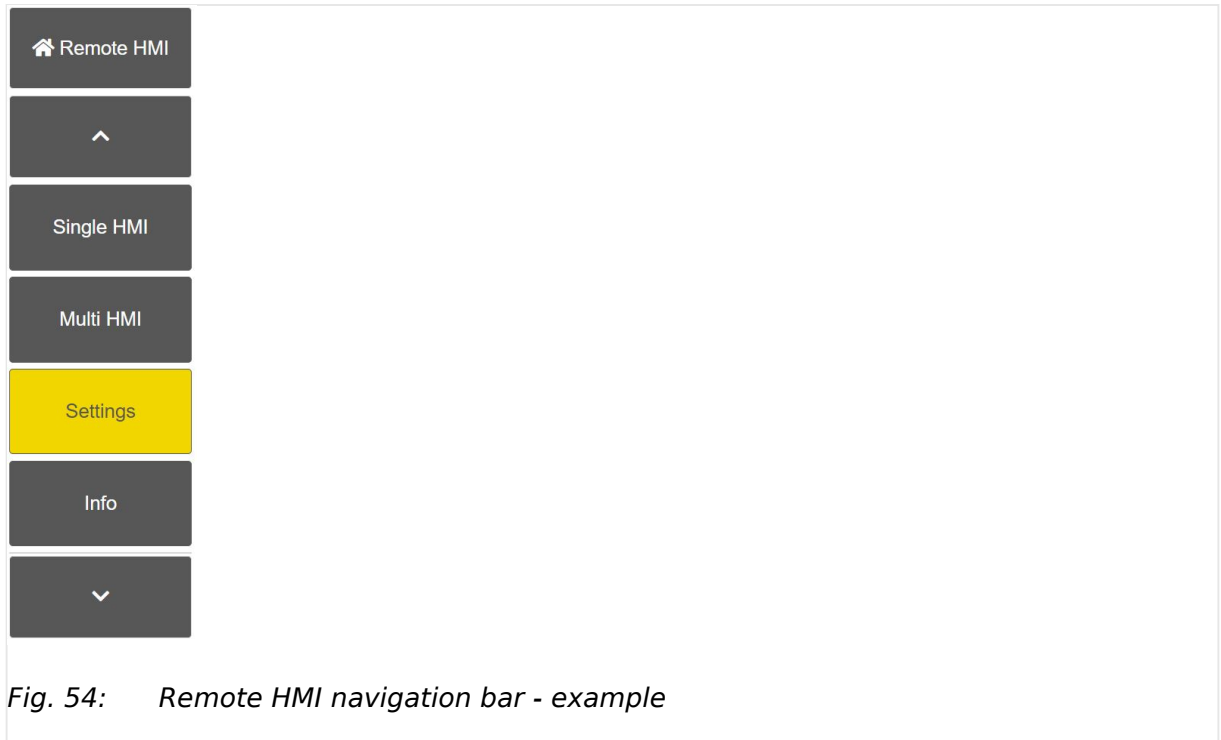

Fig. 54: Remote HMI navigation bar - example

Woodward Logo

A click on the Woodward logo will refresh the browser. The visualization will be reloaded and the configured start page is shown, refer to [↳ "Auto Connection \(area 5\):"](#).

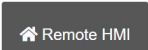

Fig. 55: Woodward Logo

5.1.2 Remote HMI pages

The following pages can be shown in content area (3) of the easYview in Remote HMI mode, refer to [↳ "5.1.1 The Remote HMI visualization"](#)

5.1.2.1 Device List page

The Device List page can be reached by clicking the  button. It shows all available easYgen-XT or LS6-XT devices in the same network as the easYview.

By default, this page is configured as start page (boot up page). How to change the start page refer to [↳ "4.2 General configuration"](#).

5 Operation

5.1.2.1 Device List page

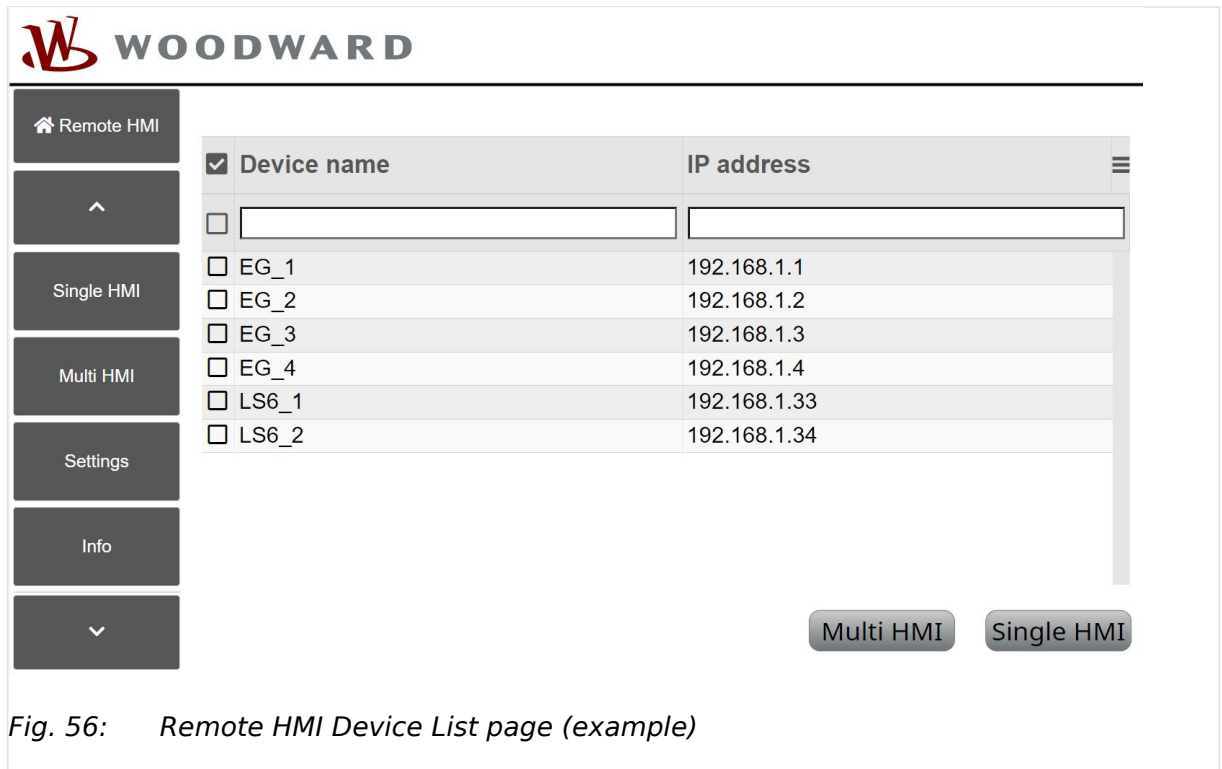
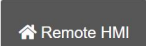

Fig. 56: Remote HMI Device List page (example)

The device list shows all available easYgen-XT and LS6-XT devices which are in same network like the easYview.



The device list is loaded only once. It will not be updated while it is open. To refresh the device list click on the  .

Select one device from the list and click the Single HMI button. After a successful connection, the Remote HMI screen of the connected device is shown, refer to [“5.1.2.2 Single Remote HMI page”](#).

If more than one device are selected and Single HMI button is clicked the following pop-up is shown.

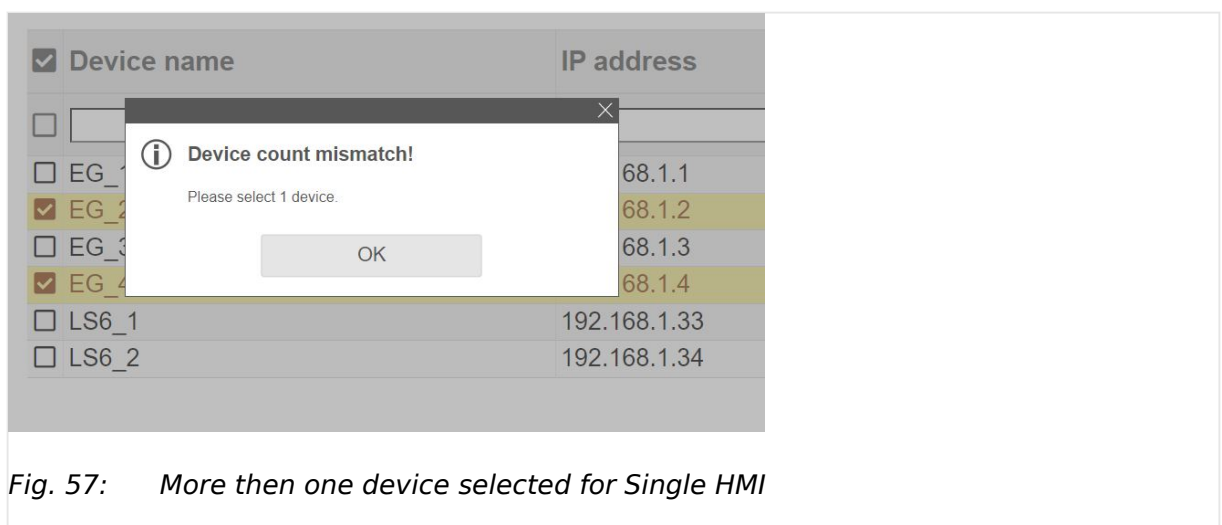

Fig. 57: More than one device selected for Single HMI

Select 1-4 devices from the list and click the Multi HMI button. After a successful connection, the Remote HMI screens of the connected devices are shown, refer to [“5.1.2.3 Multi Remote HMI page”](#).

If more than 2 devices for 10 inch or more than 4 devices for 15 inch are selected and Multi HMI button is clicked the following pop-up is shown.

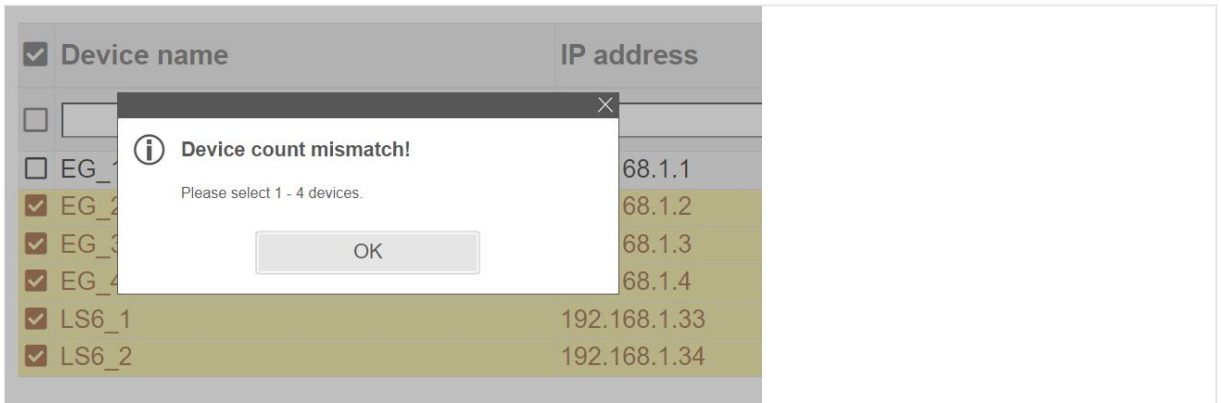

Fig. 58: More than 4 devices selected for Multi HMI at 15inch easYview



The Multi HMI mode is only available for display sizes 10 and 15 inch or if using the PC.

Before the Single/Multi HMI page is launched a VNC Server check is done.



Fig. 59: VNC Server check

If the check failed the following page is shown about 15sec.

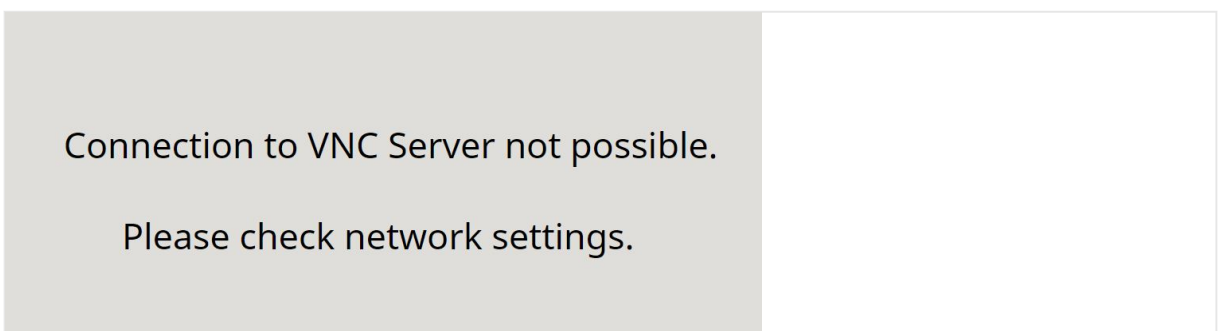

Fig. 60: VNC Server connection failed

Reasons for a VNC Server connection fail:

5 Operation

5.1.2.1 Device List page

- In the moment of the VNC Server check there is a connection lost (bad ethernet connection)
- If using another easYview as VNC Server (Cascading), the connection to the Master easYview is not valid (no connection or wrong IP address)

Check the ethernet cable and the ethernet settings to avoid these issues.

Sorting/Filtering

In the device list page it is possible to use different sorting and search options to find the desired device.

Sorting:

Selecting a column header (name or IP address) in the list view. This will activate the sorting of the available devices. Selecting the name header will sort by name, selecting the IP address header will sort by IP address. The sorting is alphabetically (also the IP address) and can be switch between ascending (0 to 9, A to Z) and descending (9 to 0, Z to A) sorting.

<input checked="" type="checkbox"/> Device name	▼ IP address
<input type="checkbox"/>	
<input type="checkbox"/> LS6_2	192.168.1.34
<input type="checkbox"/> LS6_1	192.168.1.33
<input type="checkbox"/> EG_4	192.168.1.4
<input type="checkbox"/> EG_3	192.168.1.3
<input type="checkbox"/> EG_2	192.168.1.2
<input type="checkbox"/> EG_1	192.168.1.1

Fig. 61: Devices in network (example sorting)

Search (filter):

To use the build in text search filter, select the search input fields and use the keyboard pop up window for text inputs. The search filter option is case insensitive. The wild card character (*) can be used as placeholder, regular expressions are not supported. The search applies direct after accepting the text input from the keyboard pop up ("EN").

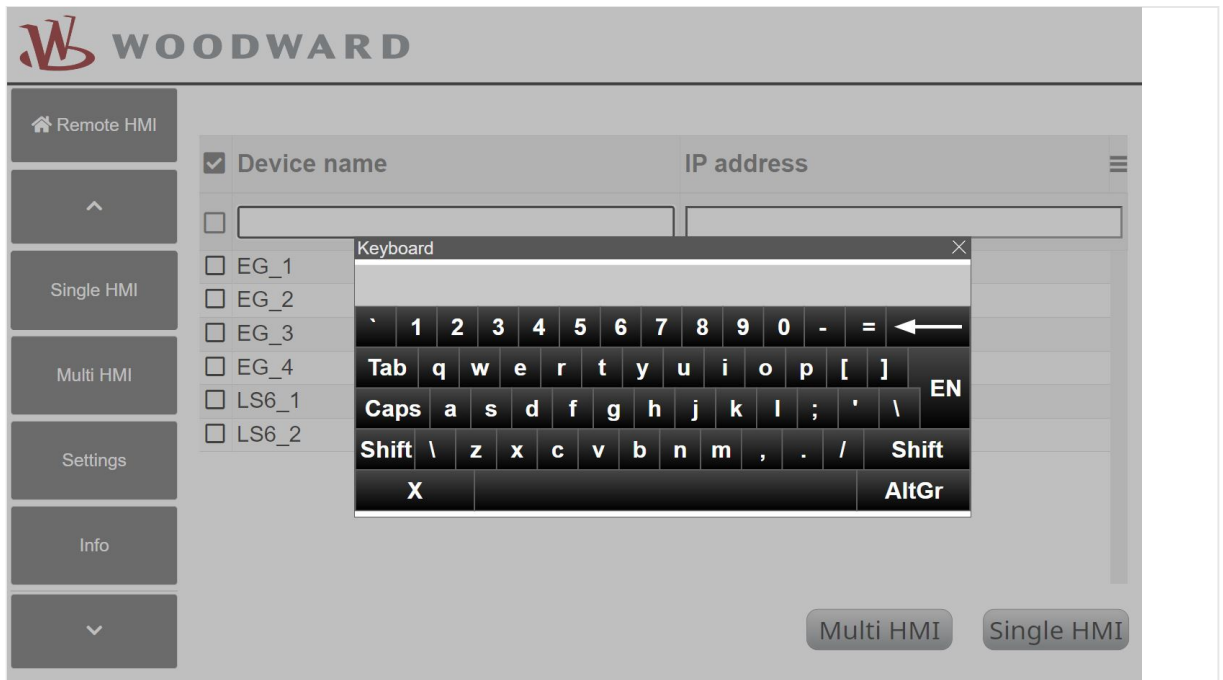

Fig. 62: Keyboard pop-up for filter entry - example

None matching results will be filter out, so only the matching results will be shown in the list.

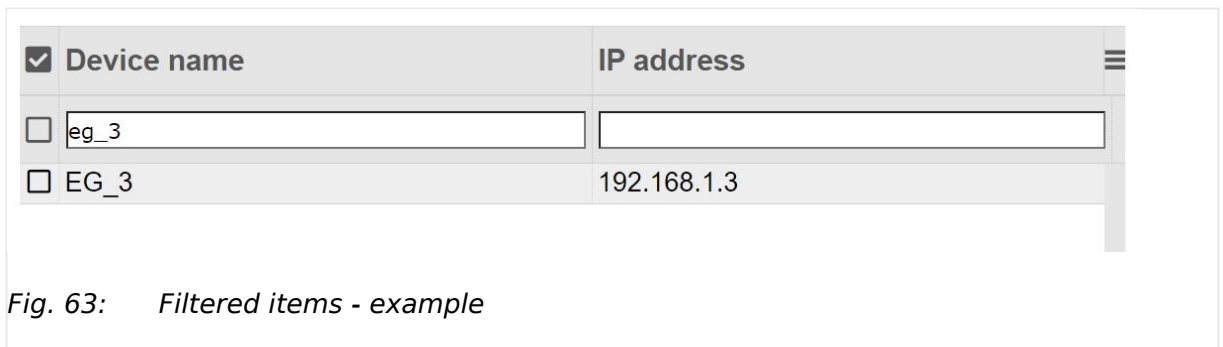
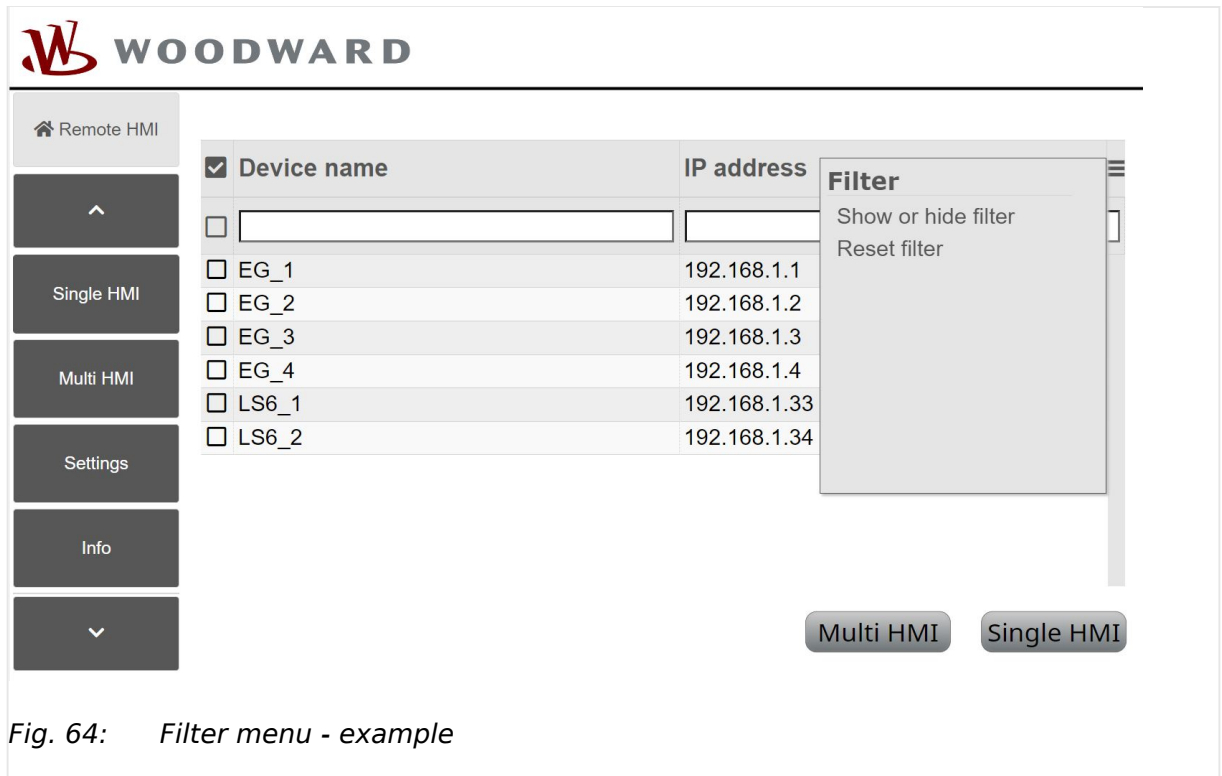

Fig. 63: Filtered items - example

Over the burger icon in the right upper corner the search filter can be reset and the search input fields can be disabled (hidden) if not needed.

5 Operation

5.1.2.2 Single Remote HMI page

**Select filter:**

Use the check box left to the search input fields to filter out already selected items. That means only the already selected item (rows) will be shown in the list. The Select Filter is only available for easYview with display size 10" and 15".

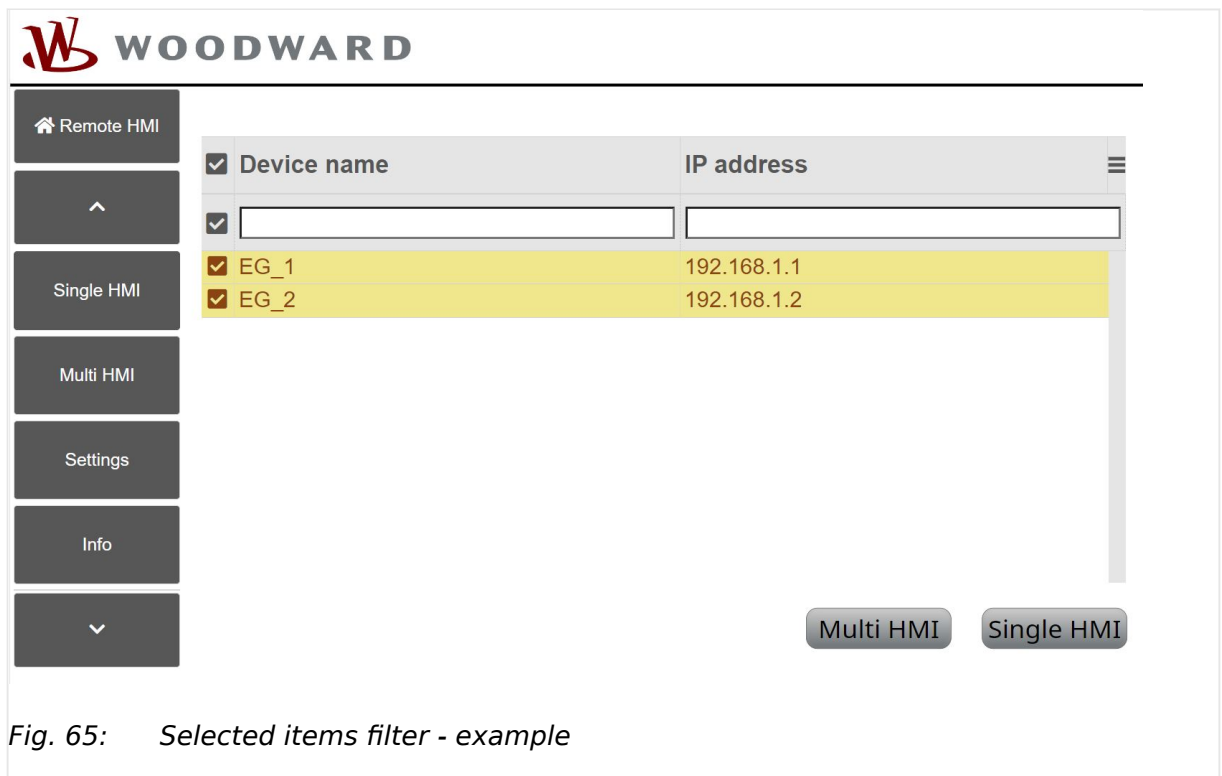
**5.1.2.2 Single Remote HMI page**

This page shows a single Remote HMI screen of an easYgen-XT or LS6-XT device.

The Single Remote HMI page can be launched by three ways:

- Selecting one device from the Device List and click **Single HMI**

This will launch the Single Remote HMI page with a new connection of the selected easYgen-XT or LS6-XT device.

- Click on the **Single HMI** button in the navigation bar.

This will launch the Single Remote HMI page with the last easYgen-XT or LS6-XT connection.

- Configure the Single Remote HMI as start page and refresh/reboot the easYview, refer to [↳ "Auto Connection \(area 5\):"](#)

This will launch the Single Remote HMI page with the last easYgen-XT or LS6-XT connection.

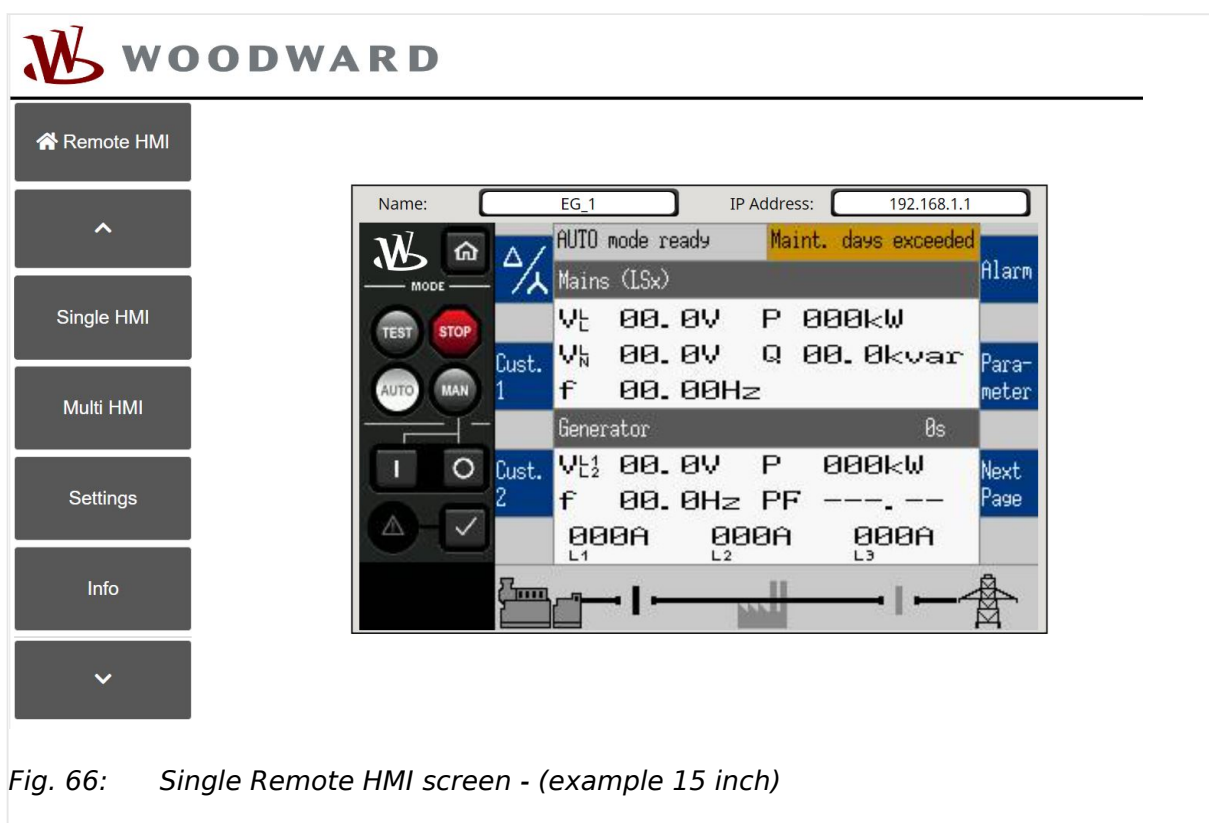

Fig. 66: Single Remote HMI screen - (example 15 inch)

5 Operation

5.1.2.3 Multi Remote HMI page

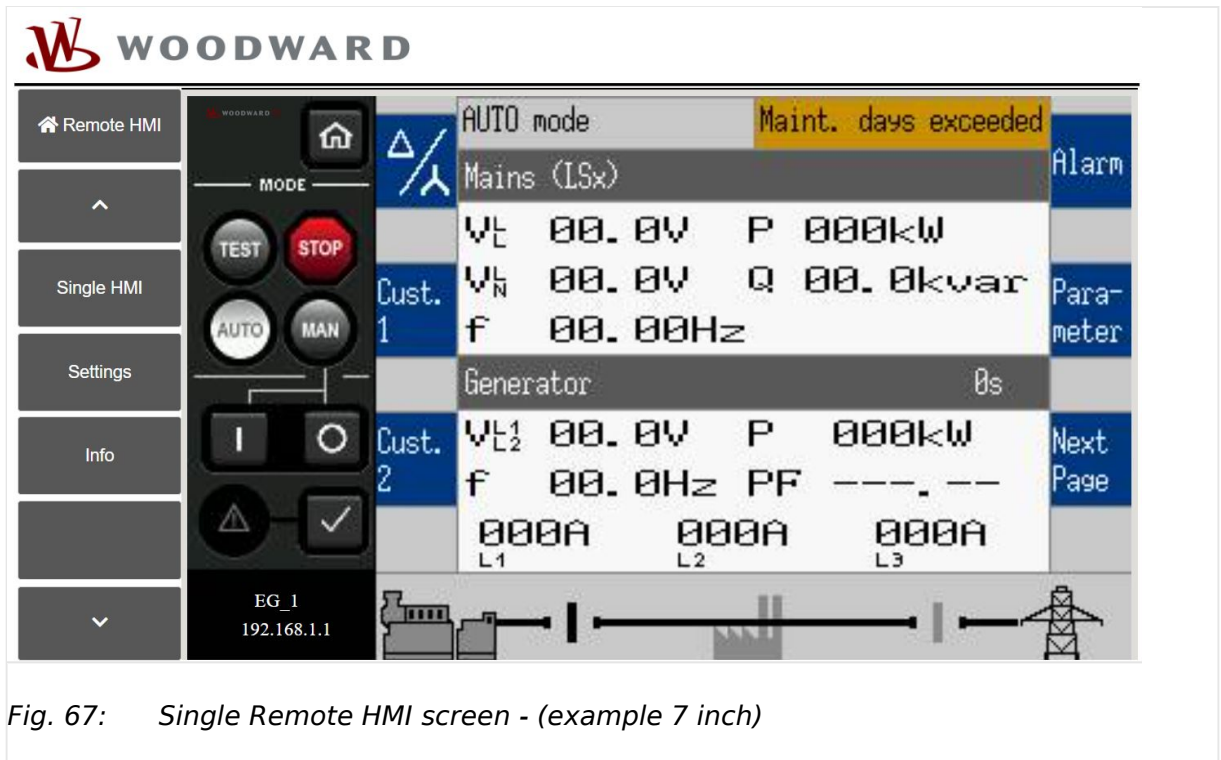

Fig. 67: Single Remote HMI screen - (example 7 inch)

How to use the Remote HMI screen, refer to [“5.3 Remote HMI Screen”](#)

5.1.2.3 Multi Remote HMI page

This page shows a multiple Remote HMI screens of an easYgen-XT or LS6-XT devices, depending on the easYview screen size.

Number of Remote HMI screens

- 7 inch: not supported (only single Remote HMI screen)
- 10 inch: maximum two Remote HMI screens
- 15 inch: maximum four Remote HMI screens.
- PC: maximum four Remote HMI screens.

The Multi Remote HMI page can be launched by three ways:

- Selecting 1-4 devices (15inch) or 1-2 devices (10inch) from the Device List and click **Multi HMI**

This will launch the Multi Remote HMI page with new connections of the selected easYgen-XT or LS6-XT devices.

- Click on the **Multi HMI** button in the navigation bar.

This will launch the Multi Remote HMI page with the last easYgen-XT or LS6-XT connections.

- Configure the Multi Remote HMI as start page and refresh/reboot the easYview, refer to [“Auto Connection \(area 5\):”](#)

This will launch the Multi Remote HMI page with the last easYgen-XT or LS6-XT connections.

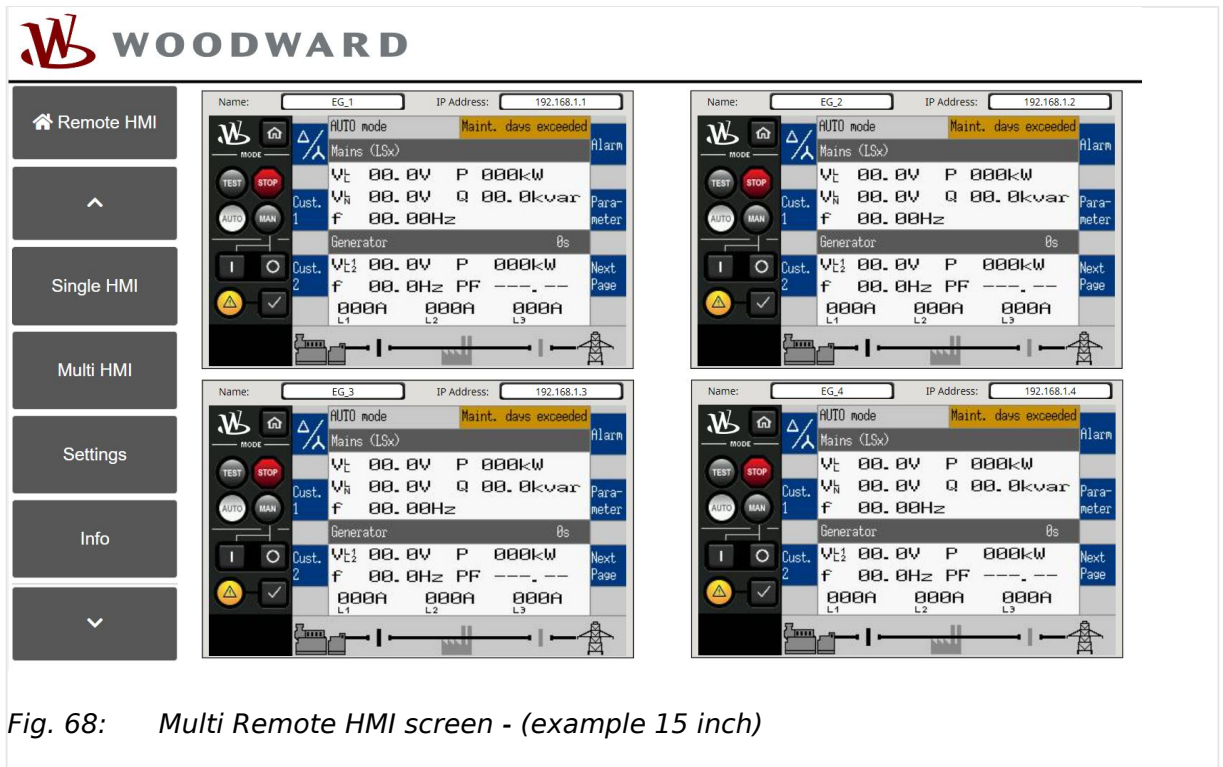

Fig. 68: Multi Remote HMI screen - (example 15 inch)

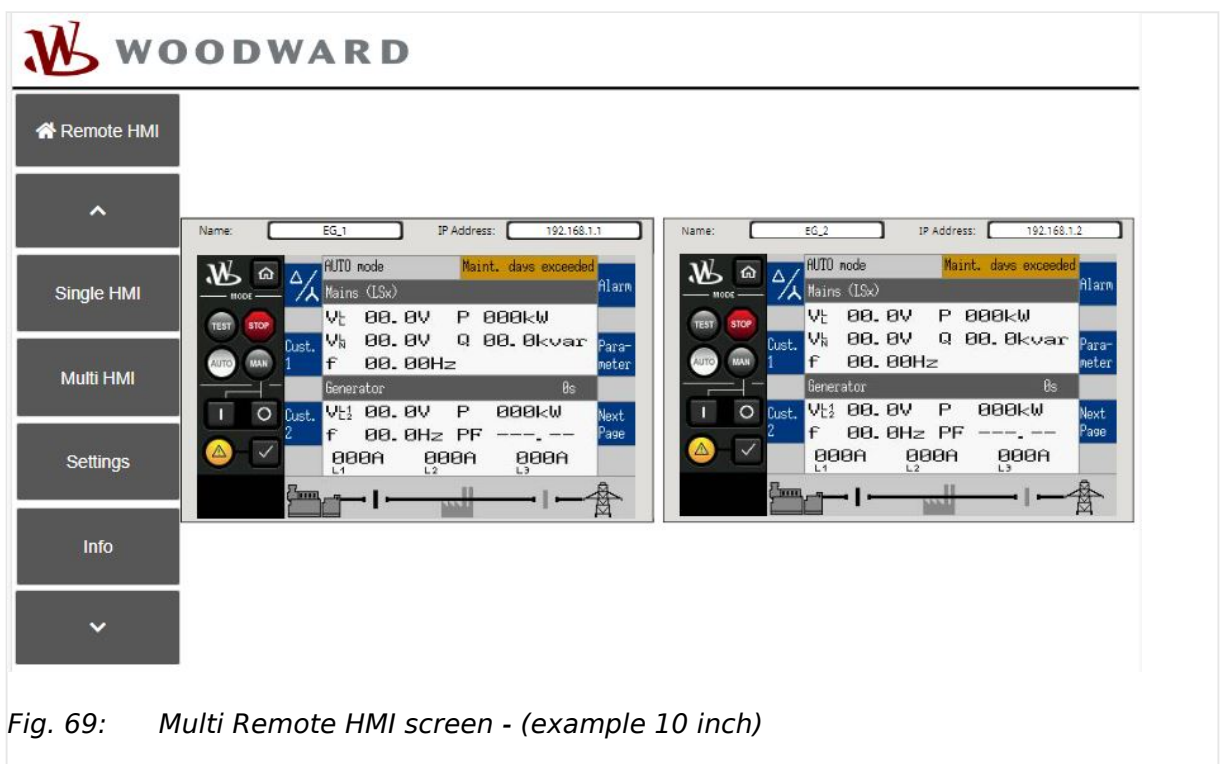
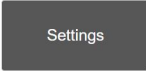
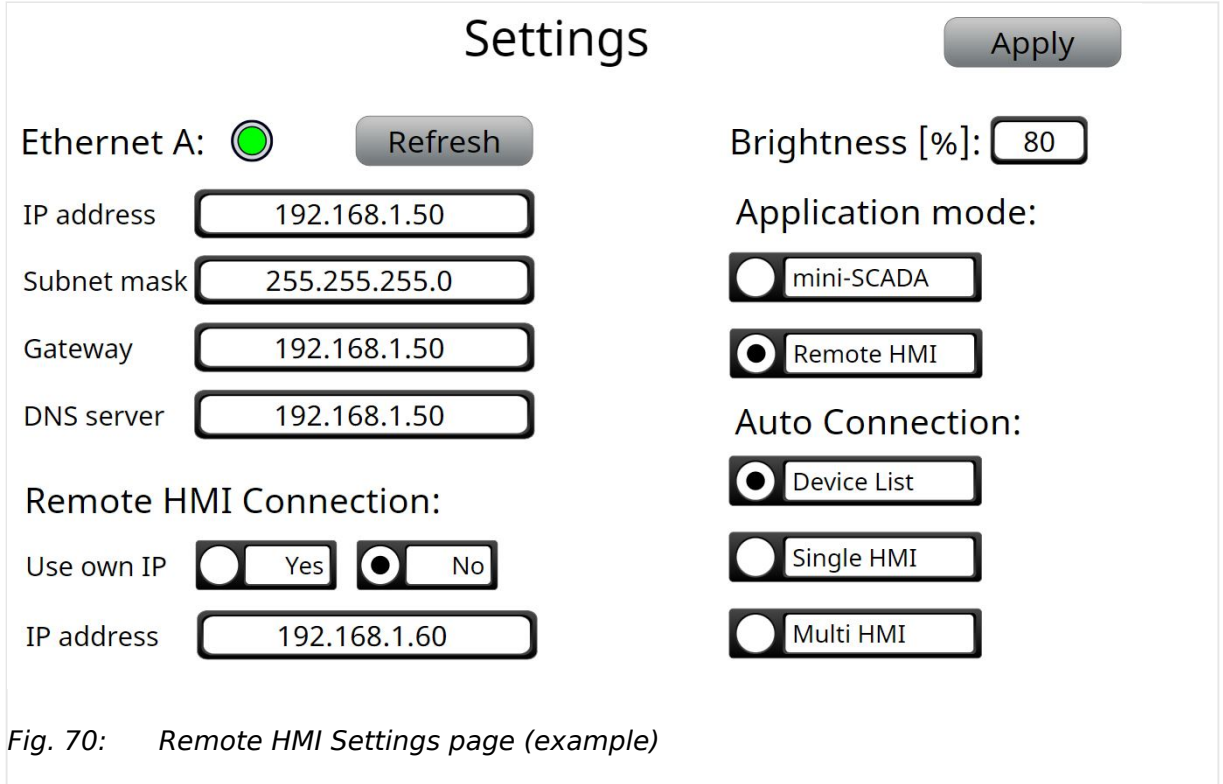

Fig. 69: Multi Remote HMI screen - (example 10 inch)

How to use the Remote HMI screens, refer to [5.3 Remote HMI Screen](#)

5.1.2.4 Settings page

This settings page can be reached by clicking the  button. It shows the settings of the easYview. Refer to [“4.2 General configuration”](#).



The screenshot shows the 'Settings' page with an 'Apply' button in the top right. The page is divided into two columns of settings:

- Ethernet A:** Includes a green status indicator and a 'Refresh' button. Below it are input fields for IP address (192.168.1.50), Subnet mask (255.255.255.0), Gateway (192.168.1.50), and DNS server (192.168.1.50).
- Remote HMI Connection:** Features a 'Use own IP' section with 'Yes' and 'No' radio buttons (selected 'No'), and an 'IP address' field (192.168.1.60).
- Brightness [%]:** A numeric input field set to 80.
- Application mode:** Three radio button options: 'mini-SCADA', 'Remote HMI' (selected), and 'Multi HMI'.
- Auto Connection:** Three radio button options: 'Device List' (selected), 'Single HMI', and 'Multi HMI'.

Fig. 70: Remote HMI Settings page (example)

NOTICE!



The Settings page is the same for both application modes (miniSCADA / Remote HMI).

5.1.2.5 The Version Info page

This page shows the version of installed software packages.

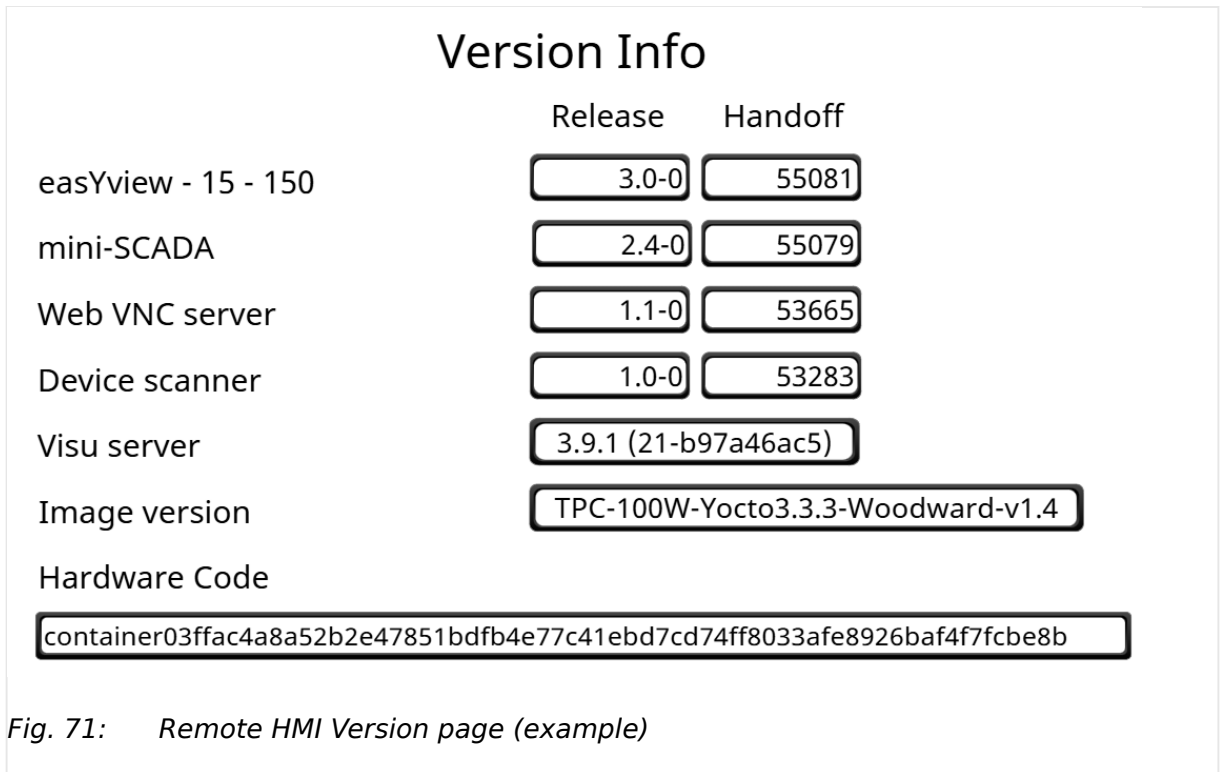
**NOTICE!**

The Version page is the same for both application modes (miniSCADA / Remote HMI).

5.2 mini-SCADA mode

In mini-SCADA mode the most important information of multiple devices are shown.

The mini-SCADA visualization can also be opened in a browser that is running e.g. on a PC by entering the IP address of the easYview. To have full access in this case the easYview should be set to "PC mode" page [↪ "5.2.2.4 The PC mode page"](#).

All customers have the possibility to modify the visualization manually. For further information refer to application note #37949 available at <http://www.woodward.com> or at the QR server <http://wwdmanuals.com/easyview>.

Modifications

WARNING!



Hazards due to customer modifications

Please be advised that any customizations made to this product are done at the customer's own risk. Woodward does not assume any responsibility or liability for any performance issues, malfunctions, or damages that may result from such customizations. Our support in these cases is strictly limited to resetting the product to its factory default settings. By customizing this product, the customer acknowledges and accepts these terms.



To change the application mode of the easYview, refer to [↳ “4.2 General configuration”](#)

5.2.1 The mini-SCADA visualization

The mini-SCADA screen offers three areas of information and communication/control:

- 1 At the top there are the logo, a common alarm bell and all navigation elements which have a general meaning to all connected devices.
- 2 The left part of the screen is the navigation bar for all available devices.
- 3 The right part of the screen is the content of the visualization pages. It is cyclically updated.

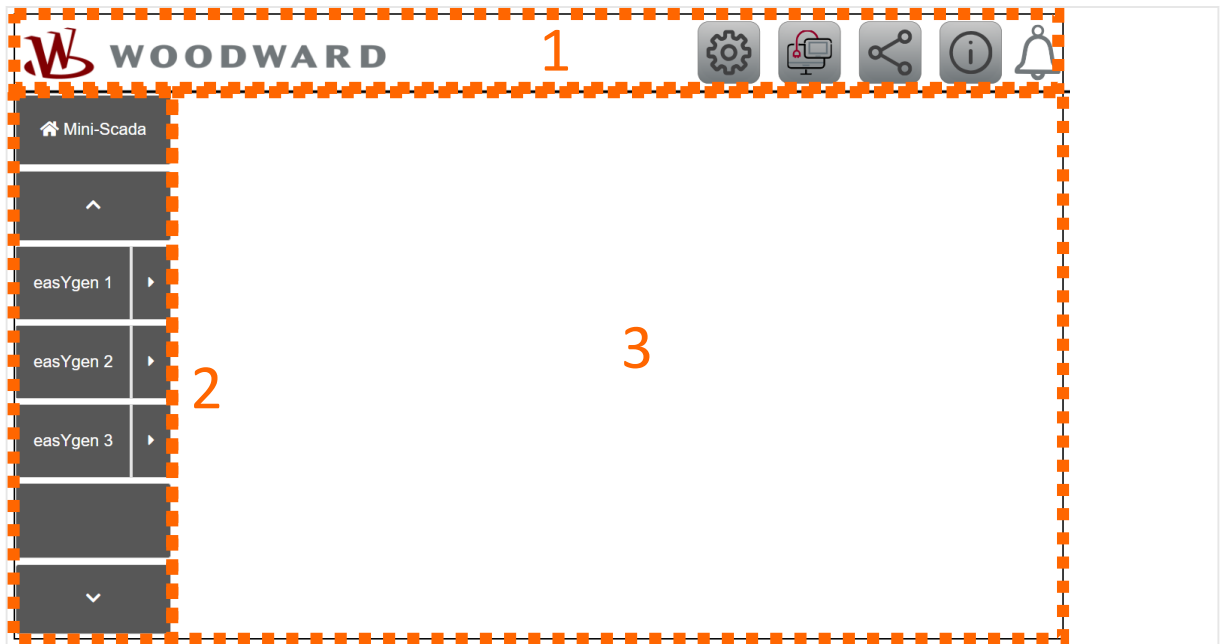

Fig. 72: mini-SCADA pages - active areas

- 1 Logo, navigation buttons and alarm information
- 2 Navigation bar
- 3 Content of the mini-SCADA visualization pages

Navigation bar

The actual shown page is highlighted yellow, see [↪ Fig. 73](#).

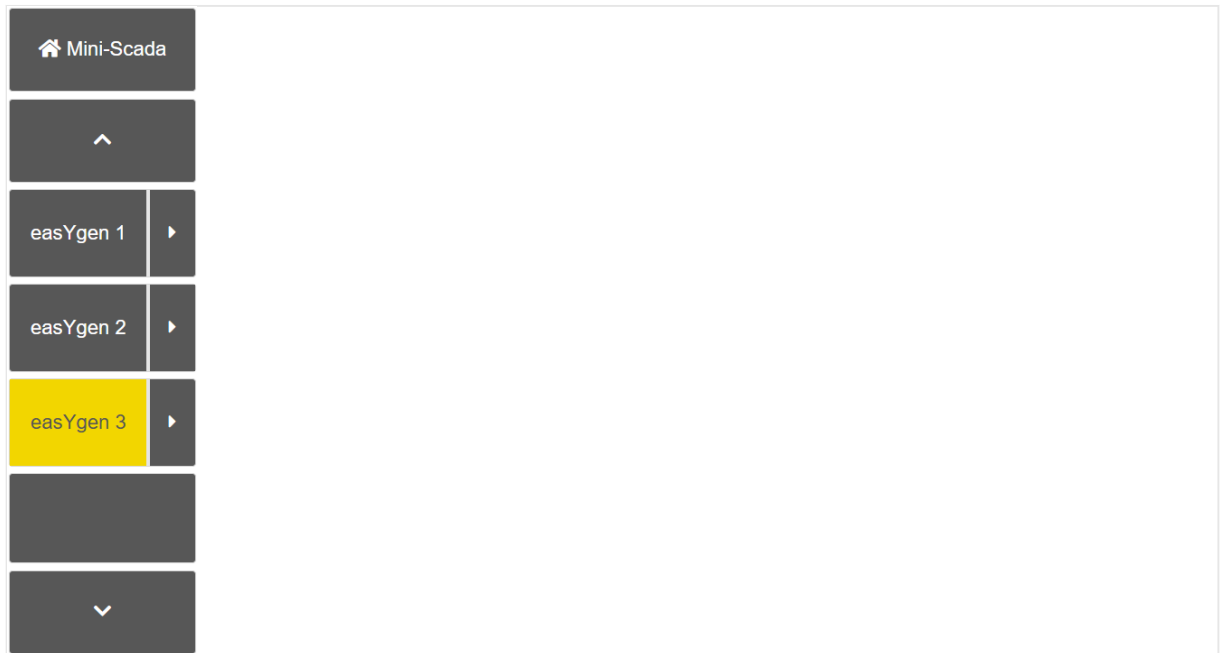

Fig. 73: mini-SCADA navigation bar - example

With the small arrow to the right the navigation bar opens the subpage navigation. Here sub pages can be added for the according easYgen-3000XT, see [↪ Fig. 74](#).

5 Operation

5.2.1 The mini-SCADA visualization

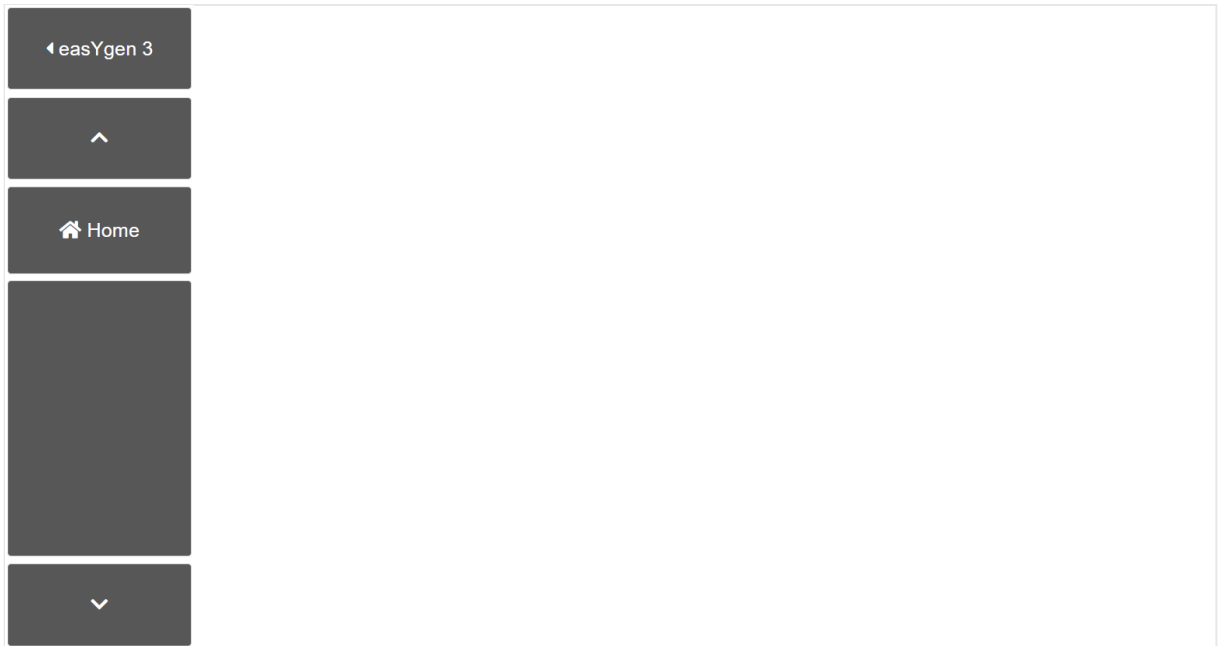

Fig. 74: mini-SCADA navigation subpages - example

Navigation to general pages and status of common alarm

The navigation buttons (1-4) refer to general pages with information and settings.

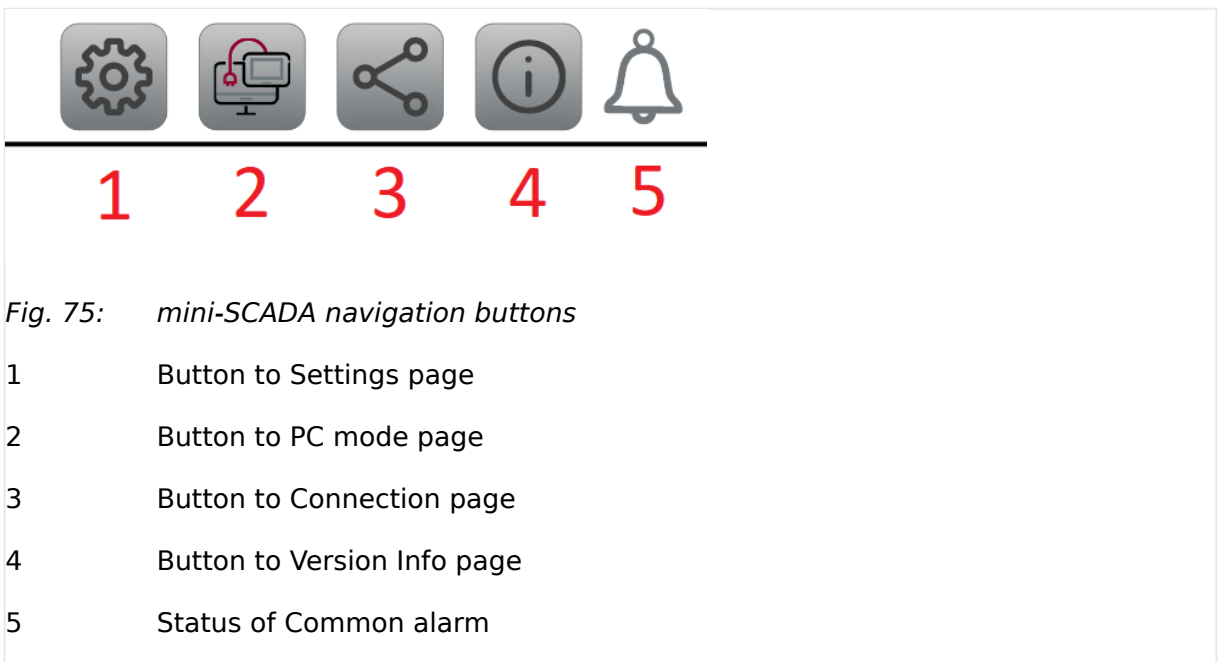

Fig. 75: mini-SCADA navigation buttons

- 1 Button to Settings page
- 2 Button to PC mode page
- 3 Button to Connection page
- 4 Button to Version Info page
- 5 Status of Common alarm

Woodward Logo



A click on the Woodward logo will refresh the browser. The visualization will be reloaded and the start page (MultiDevice) is shown.



Fig. 76: Woodward Logo

Status of common alarm

The bell (5) shows the status of the common latched alarm. It is cyclically updated.

Status	Description of common latched alarm
	no alarm active
	Latched common Warning alarm (class A, B)
	Latched common Shut down alarm (class C, D, E, F)

5.2.2 mini-SCADA pages

These pages are shown when the easYview is in mini-SCADA mode.

5.2.2.1 The Multi Devices page

This page shows the mini-SCADA visualization. Multiple gensets controlled by according easYgen-3000XT run in parallel to the mains. The most important AC values, the breaker states and the alarm state are shown.

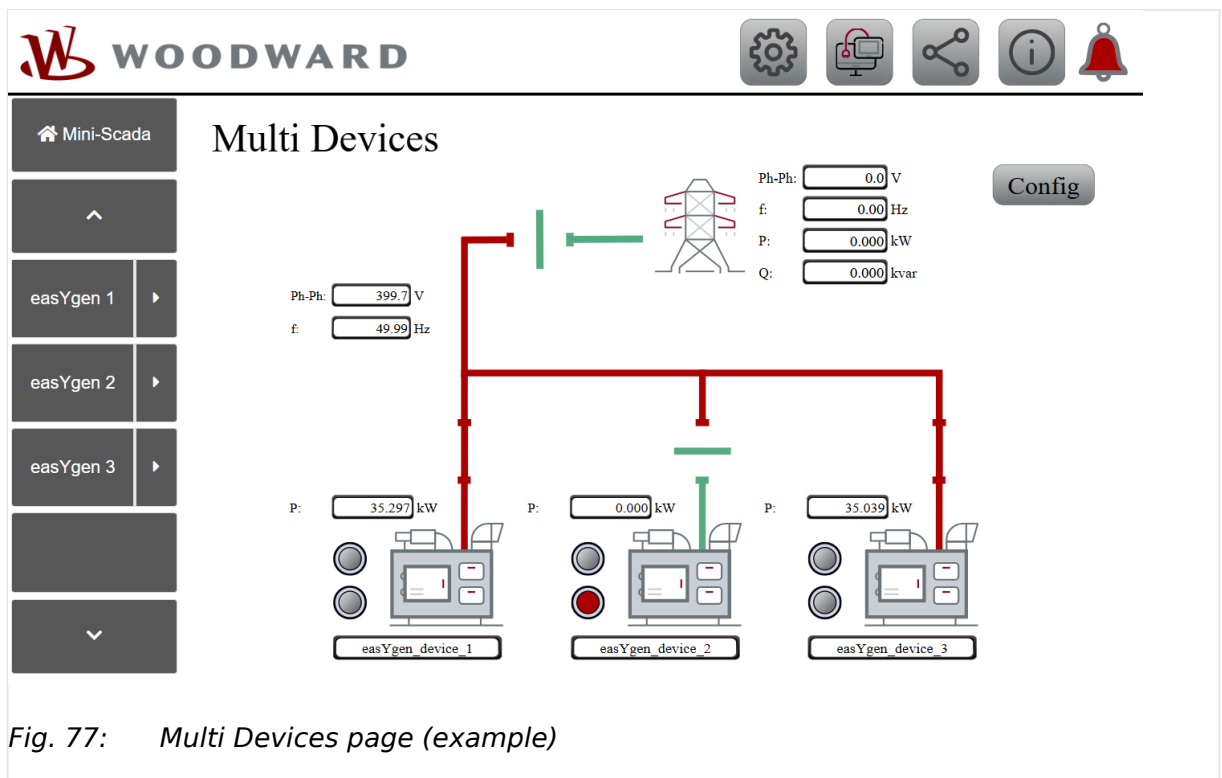

Fig. 77: Multi Devices page (example)

The following parts can be configured

In the Connection Settings page the number of active (shown) gensets can be configured.

Pushing the button  in the Multi Devices page the following functions of this page can be configured:

5 Operation

5.2.2.1 The Multi Devices page

- The color of the active busbar
- If the mains values are directly measured by an easYgen-3000XT
 - The number of the easYgen-3000XT that measures the values and provides the MCB information
- The source of the mains values
 - Directly measured by an easYgen-3000XT
 - Measured by an LS-6XT and transferred to an easYgen-3000XT

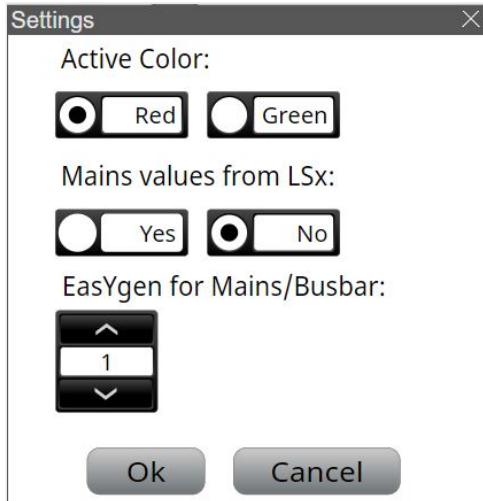

Fig. 78: Config Multi Devices page (example)

When the source of the mains values is configured to a disabled easYgen-3000XT the following dialog pops-up:

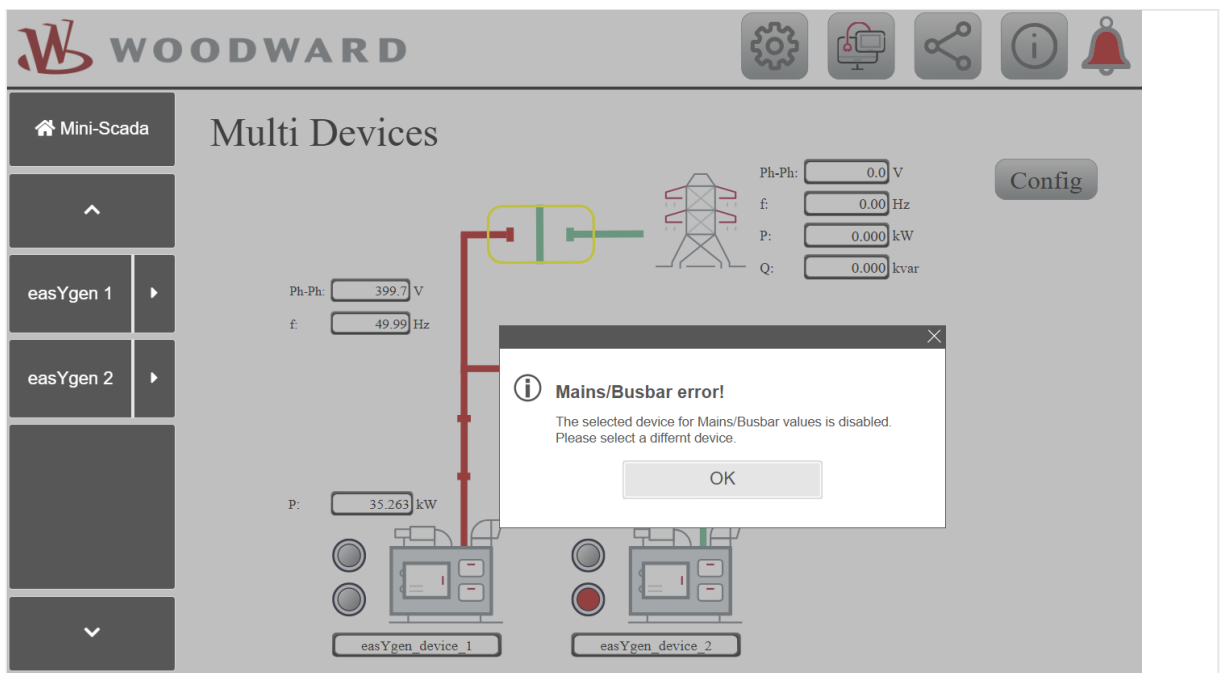

Fig. 79: Multi Devices page - mains error dialog

Multi Devices page with less than three easYgens

The easYview-07-030, easYview-10-150 and easYview-15-150 HMI solution offers a visualization of up to 3 (7 inch hardware) or 4 (10/15 inch hardware) easYgen-3000XT. The default setting is a plant overview where all available easYgen-3000XT devices are shown. If the project requires a reduced number of easYgen-3000XT, the surplus devices can be disabled by configuration. The needed easYgen devices are defined in the Connection settings page [↪ “5.2.2.3 Connection Settings page”](#).

The example below shows the Multi Devices page with disabled easYgen number 2:

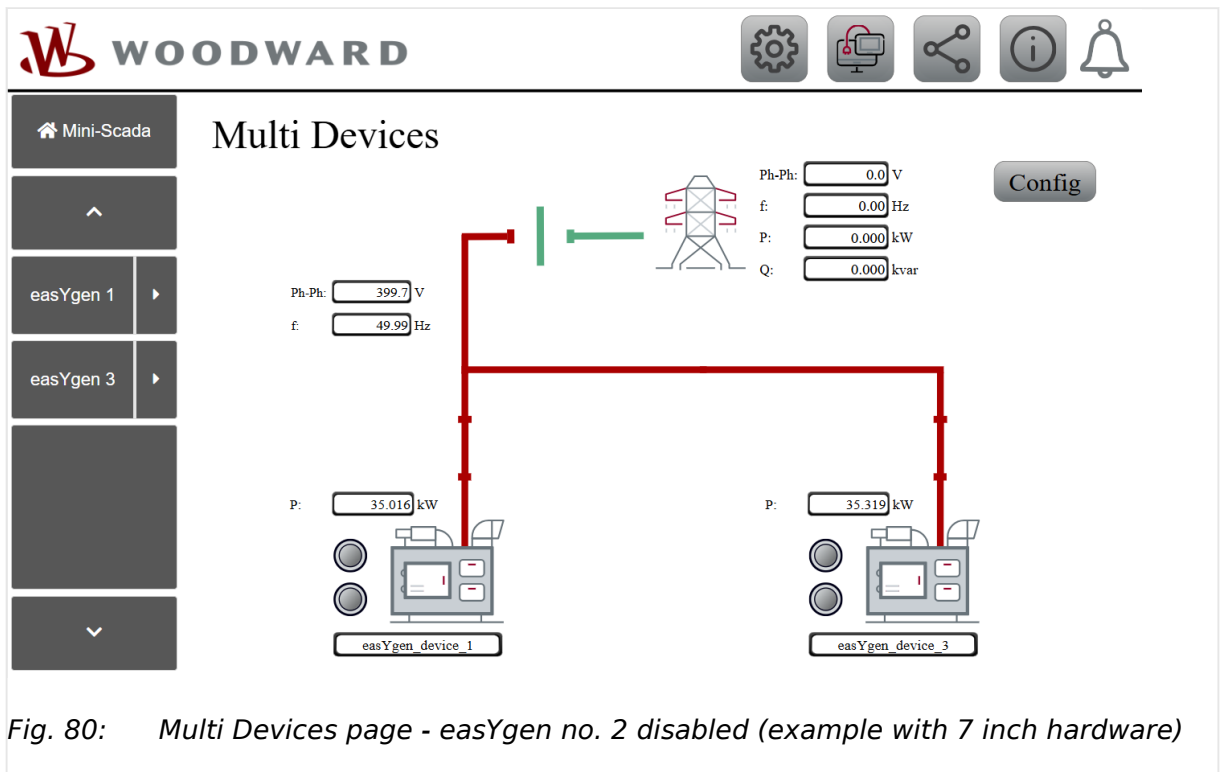

Fig. 80: Multi Devices page - easYgen no. 2 disabled (example with 7 inch hardware)

5.2.2.2 easYgen HOME page

This page shows AC values of one generator and the device name of the connected easYgen-3000XT.

5 Operation

5.2.2.2 easYgen HOME page

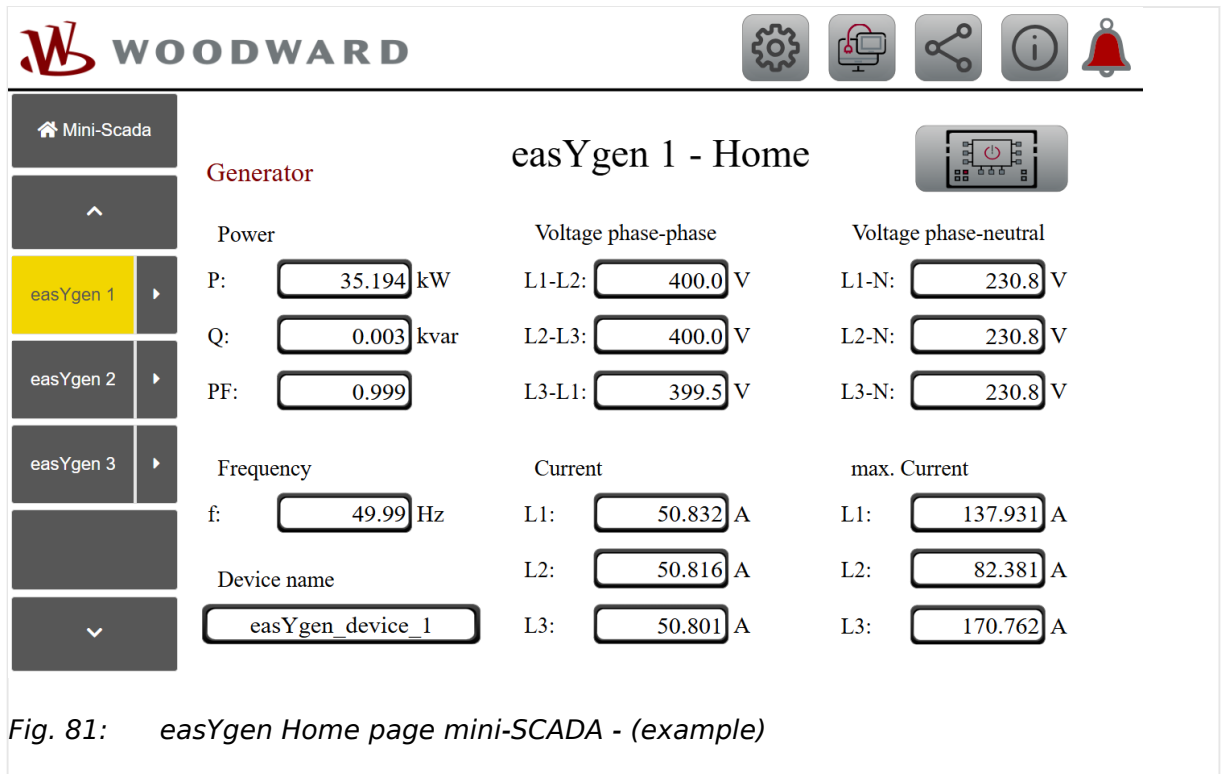

The button  leads to the remote control Remote HMI screen of the connected device. The Remote HMI screen can be used like described in [“5.3 Remote HMI Screen”](#)

First it establishes a connection to the configured Remote HMI server, refer to [“IP address for Remote HMI \(area 2\):”](#).

Before the Remote HMI screen is launched a VNC Server check is done.



If the check failed the following page is shown after about 15sec.

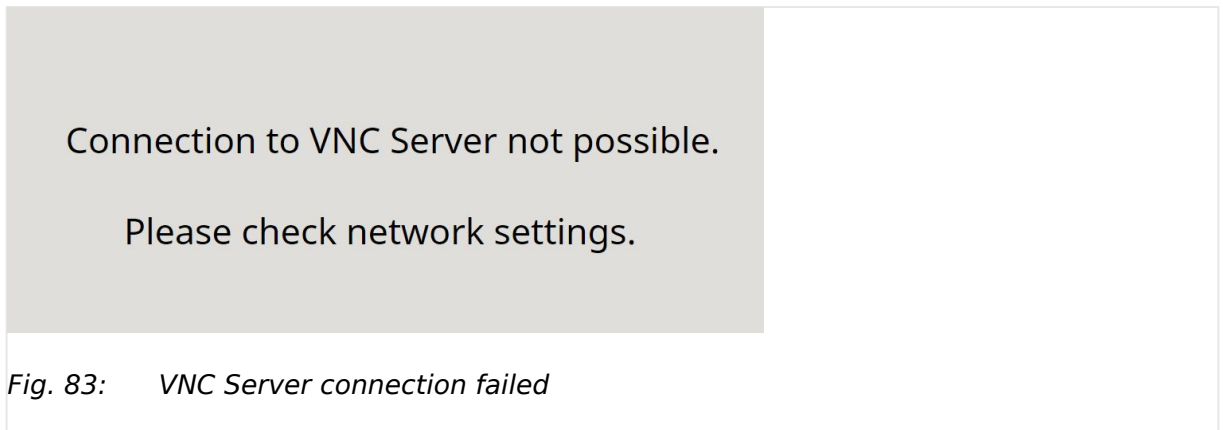

Verify that the ethernet cable is plugged in correct and the IP address of the configured Remote HMI server is configured properly.

If the connection to the Remote HMI server was successful, the Remote HMI server tries to connect to the configured easYgen-XT, refer to ["Connection page easYgen-XT"](#). After successful connection the Remote HMI screen is shown.

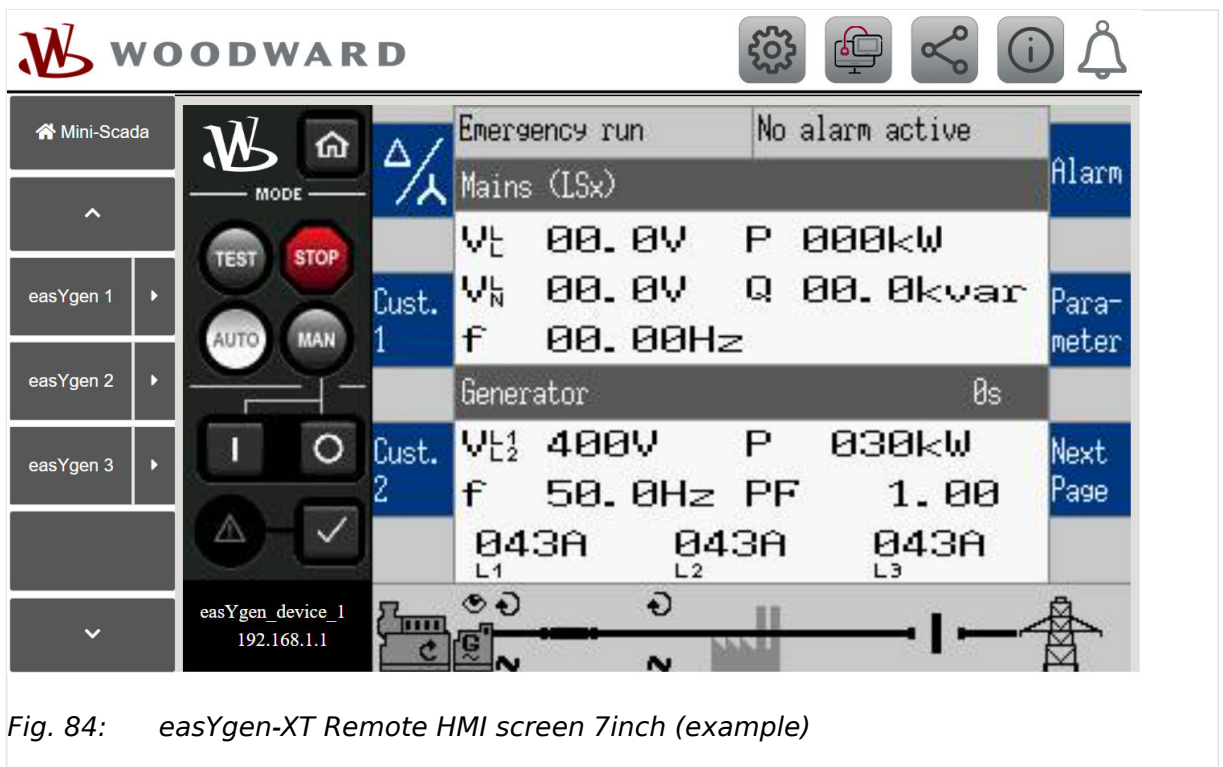

5 Operation

5.2.2.3 Connection Settings page

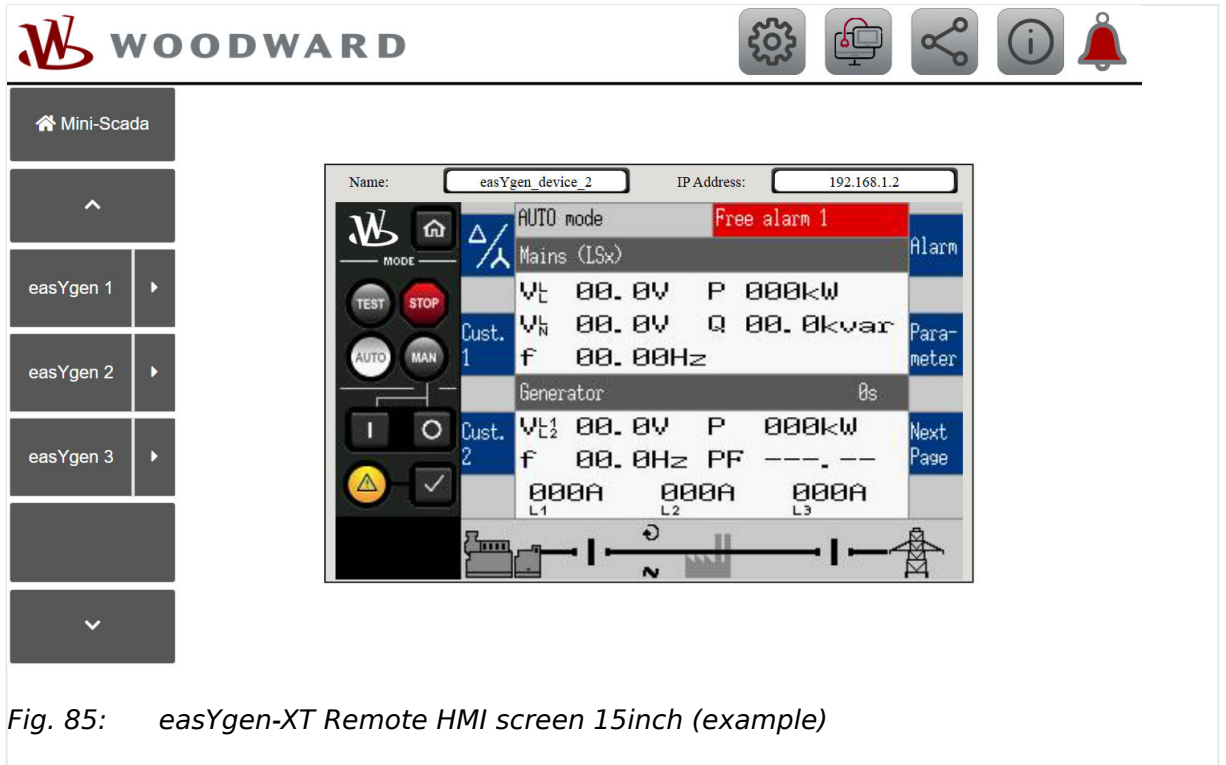

Fig. 85: easYgen-XT Remote HMI screen 15inch (example)

5.2.2.3 Connection Settings page

This page defines the connection to the easYgen-3000XT devices, for further information refer to [4.3 Application Configuration](#).

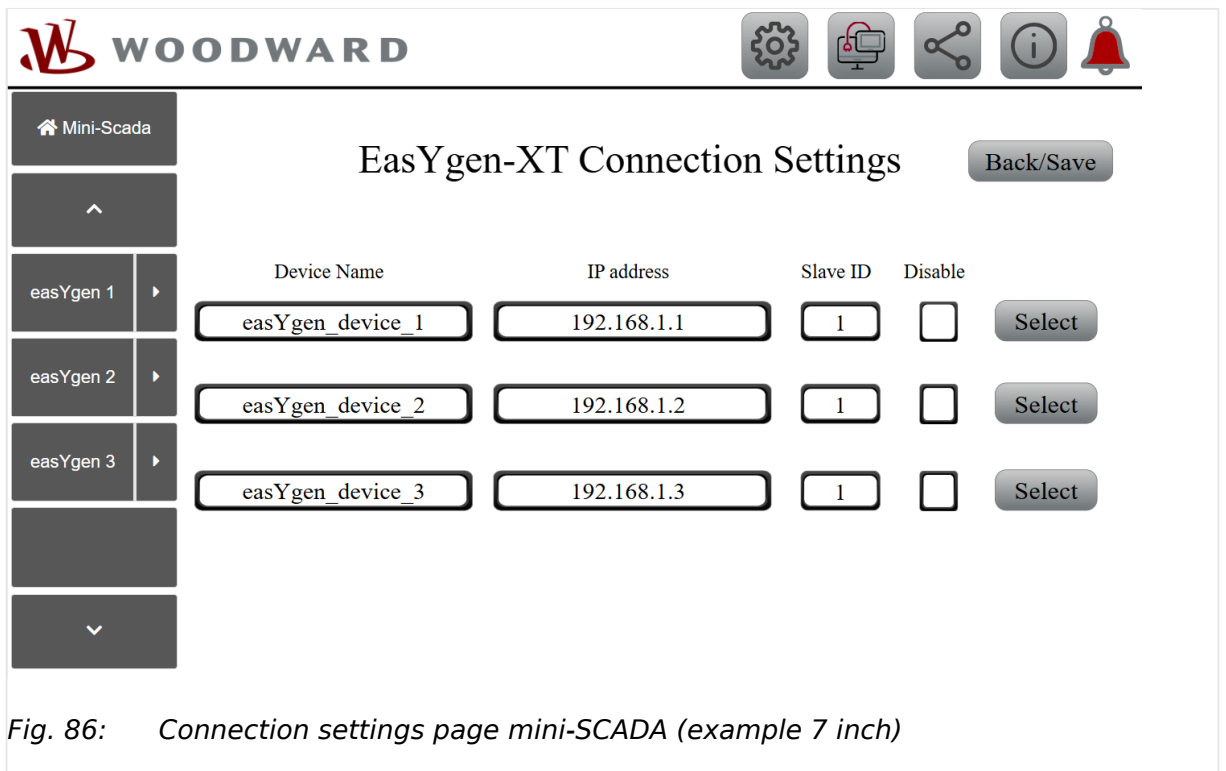

Fig. 86: Connection settings page mini-SCADA (example 7 inch)

Back/Save

EasYgen-XT Connection Settings

Device Name	IP address	Slave ID	Disable	
easYgen_device_1	192.168.1.1	1	<input type="checkbox"/>	Select
easYgen_device_2	192.168.1.2	1	<input type="checkbox"/>	Select
easYgen_device_3	192.168.1.3	1	<input type="checkbox"/>	Select
easYgen_device_4	192.168.1.4	1	<input type="checkbox"/>	Select
easYgen_device_5	192.168.1.5	1	<input checked="" type="checkbox"/>	Select
easYgen_device_6	192.168.1.6	1	<input checked="" type="checkbox"/>	Select
easYgen_device_7	192.168.1.7	1	<input checked="" type="checkbox"/>	Select
easYgen_device_8	192.168.1.8	1	<input checked="" type="checkbox"/>	Select
easYgen_device_9	192.168.1.9	1	<input checked="" type="checkbox"/>	Select

Fig. 87: Connection settings page mini-SCADA (example 10 and 15 inch)

- Define the IP address of the connected easYgen-3000XT devices
- Set the Modbus Slave ID of the connected easYgen-3000XT devices (needed in mini-SCADA mode only)
- Enable / disable devices for the visualization and the Multi Devices page
- Leads with the 'Select' button to an overview screen of all devices that are available in this network.

5.2.2.4 The PC mode page

The mini-SCADA visualization is a client and opens a session to the visualisation server. Each data variable that gets displayed in the visualization needs one connection, called CCD. The amount of CCDs is limited through the Atvise license, refer to [“5.5 Licensing”](#). In mini-SCADA mode, the visualization can be opened in several browsers in parallel (e.g. additionally on a PC). The needed connections are summed-up, so if you connect to the visualization from two browsers on the same machine, both will count CCDs.

Therefore, the PC mode can be activated on the easYview by pressing the PC mode button. The PC mode page uses only one connection (common alarm). If the visualization is opened in a separate browser on a PC, it has the maximum amount of the licensed CCDs available.

5 Operation

5.2.2.5 The Version Info page

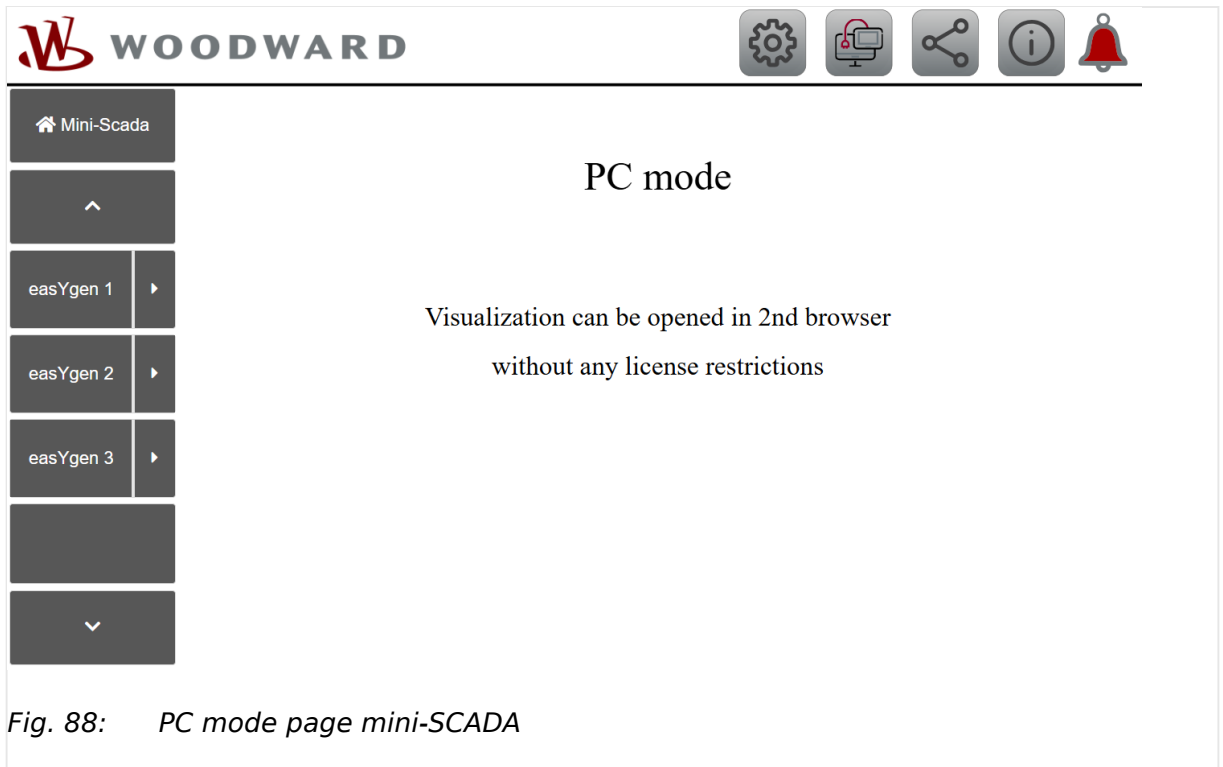

Fig. 88: PC mode page mini-SCADA

If the number of CCDs is exceeded the message 'CCD exceeded!' pops-up.

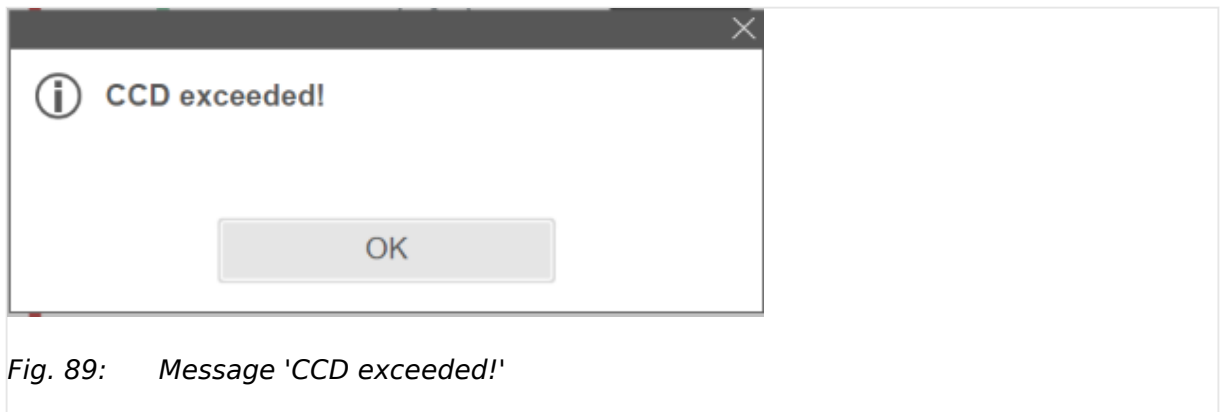

Fig. 89: Message 'CCD exceeded!'

Activate PC mode on easYview and refresh or close/reopen the browser on the PC.



After a refresh of the visualization on a PC browser, the MultiDevice page is shows.

5.2.2.5 The Version Info page

This page shows the version of installed software packages.

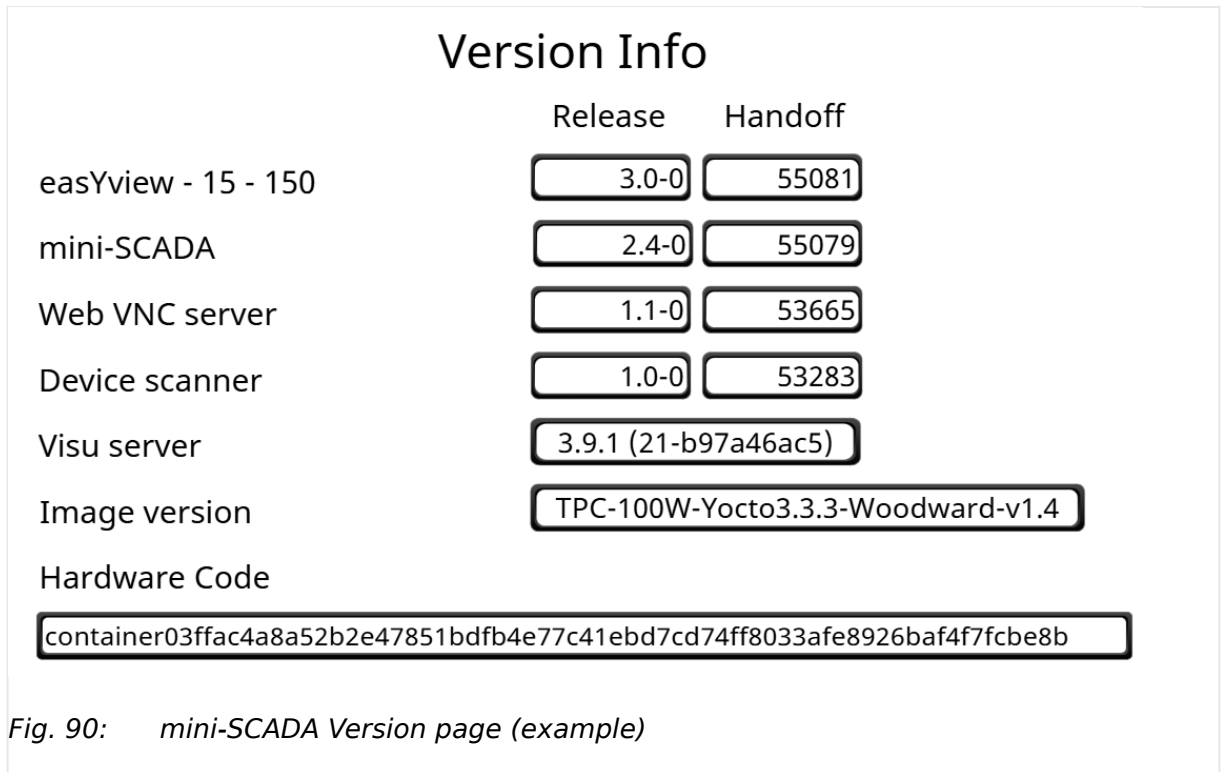

5.3 Remote HMI Screen

The operation of the easYview Remote HMI screen is similar to the operation of the easYgen-3000XT Series genset controllers.

- For detailed information about the operation of the easYview Remote HMI screen please refer to the chapter "Operation" of the easYgen-3000XT or LS-6XT Series manual.
- EasYgen-3000XT front panel buttons are re-arranged and at the left hand side of the easYview Remote HMI screen. Similarly, LS-6XT shows additional front panel buttons at the left hand side.
- The easYgen-3000XT or LS-6XT soft keys "moved directly into" the blue backgrounded softkey area of the Remote HMI screen.

Access and Level of Control

The Remote HMI screen of the easYview shows the same content like the easYgen-3000XT Series genset controllers HMI. The difference between these two devices is, that the easYview remotely controls the operation of the easYgen-3000XT Series.

The level of control is not depending on the easYview device but on the password level. EasYview can access all password levels of the easYgen-3000XT. This is also correct for the LS-6XT. The LS-6XT provides a similar HMI like the easYgen-3000XT series.

Operating the Remote HMI screen

The Remote HMI screen is shown on the Single HMI page, Multi HMI page or if launch from the easYgen Home page via the button 

5 Operation

5.3 Remote HMI Screen

It offers four areas of information and communication/control:

- The right part of the screen emulates the easYgen-3000XT HMI screen. It is cyclically updated (area 4).
 - Push buttons now work by a touch on the blue area instead of the soft key buttons.
- The left part of the screen emulates all control buttons at the front panel of an easYgen-3000XT (plastic housing) with HMI (area 2).
 - The buttons are re-arranged to fit the available space.
 - The function of the buttons is the same as on a display variant easYgen-3000XT.
- Depending on the display size, the IP address and the device name of the currently connected easYgen-3000XT has different locations (area 1 and 3).

For 7 inch easYview: On the left lower corner, refer to  Fig. 91 (area 3)

For 10 and 15 inch easYview: On the top of the Remote HMI screen, refer to  Fig. 92 area (1)

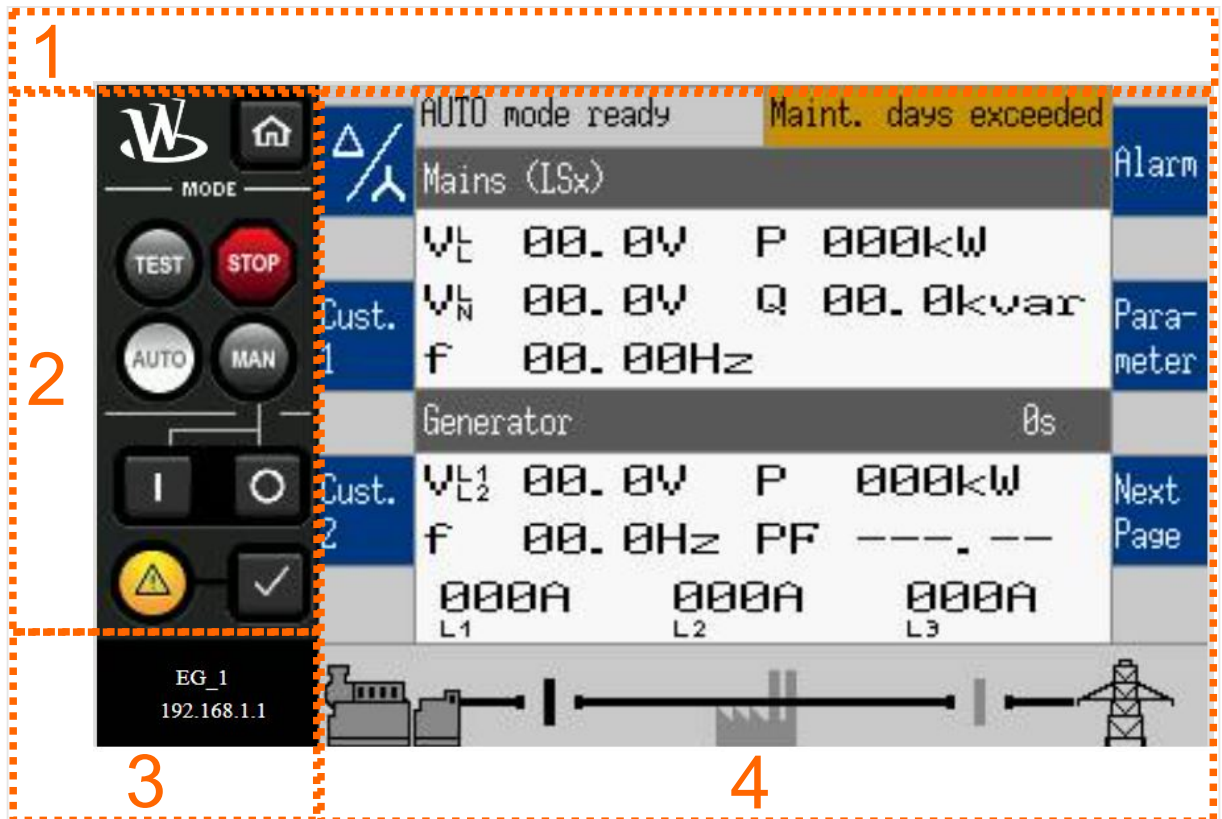

Fig. 91: Remote HMI screen of easYgen-XT - example easYview 7 inch

- 1 Empty field for easYview 7 inch
- 2 Buttons of the easYgen-3000XT front panel
- 3 Ethernet device name and/or IP address of the remotely controlled easYgen-3000XT
- 4 easYgen-3000XT screen with soft button functionality included

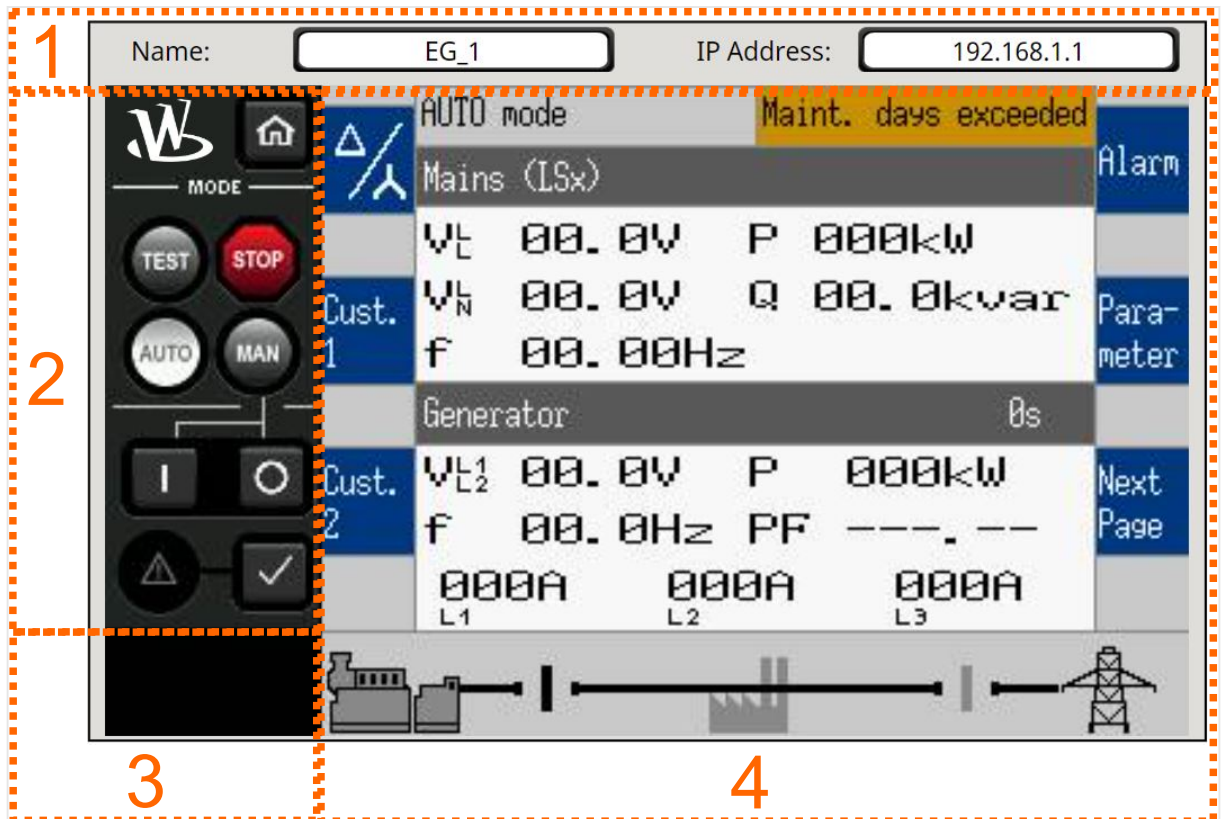

Fig. 92: Remote HMI screen of easYgen-XT - example easYview 10/15 inch

- 1 Ethernet device name and IP address of the remotely controlled easYgen-3000XT
- 2 Buttons of the easYgen-3000XT front panel
- 3 Empty field for easYview 10 and 15 inch
- 4 easYgen-3000XT screen with soft button functionality included

Error/State messages

When a Remote HMI connection shall be established, the following state order is shown.

State messages:

- "Checking VNC Server...": First the easYview checks if the VNC Server is available.
- "Connecting to Server...": Second the easYview allocates a free port and connects to the VNC Server.
- "Checking IP address...": The easYview checks if a IP address of the easYgen-XT or LS6-XT device was selected (only in Remote HMI mode for Multi HMI view).
- "Connecting...": The easYview connects to the easYgen-XT or LS6-XT device.

In case of an error the follow messages may occur.

Error messages:

- "Connection to VNC Server not possible. Please check network settings."

- Is shown either if the Ethernet cable is not plugged-in or the wrong VNC Server IP address is configured, refer to [↳ “3.2.5.2.2 Cascading feature”](#)
- "Connection failed! Please refresh the page."
 - This message may occur if multiple easYview devices request a Remote HMI connection at the same time.
- "No device selected!"
 - This message can only be shown in Multi HMI view if not all devices are selected from the device list.
- "No free VNC connection available!"
 - This message occur if all 5 ports are already used by VNC Server instances and another Remote HMI connection is requested.
- "Connecting..."
 - If this message is shown permanently, the easYview is not able to connect to an easYgen-XT or LS6-XT device. Check if the IP address of the easYgen-XT or LS6-XT is correct and there is no active VNC connection.

5.4 Personalization

If your project requirements are not covered by off-the-shelf easYview it is possible to make customizations at several points.

5.4.1 Change logo

It is possible to replace the power-up screen image, the logo in Remote HMI pages and on top of mini-SCADA visualization pages by your desired logo. Refer to application note 37946 available at <http://www.woodward.com> or at the QR server <http://wwdmanuals.com/easyview>.

5.4.2 Change Multi Devices Page

The mini-SCADA Multi Devices page can easily be personalized via different settings.

- Pushing the button  from the Multi Devices page, for more details refer to [↳ “5.2.2.1 The Multi Devices page”](#)
- Disable/Enable single devices from the Connection page, for more details refer to [↳ “5.2.2.3 Connection Settings page”](#)

If there is a need for additional customization of the mini-SCADA visualization (adding/removing pages, values or device, etc.), please refer to [↳ “Sample application setup mini-SCADA mode”](#)

5.5 Licensing

The easYview is already licensed and ready to use. Anyway there are some license restrictions, depending on the hardware (display size). These restrictions are only to consider if the mini-SCADA shall be customized, please refer to [↪ “Sample application setup mini-SCADA mode”](#).

	CCDs	MirrorNodes	Data sources
7 inch	30	1500	3
10 inch	150	9000	6
15 inch	150	9000	6

Table 8: License restrictions

- **CCDs:** Data points/values which are show in the Visualization at the same time.
- **MirrorNodes:** Datapoint which receive a value from a data source and save it in the project for use in the Visualization.
- **Data sources:** Atvise Connect is used as data source in the easYview to receive ModbusTCP data from the easYgen-3000XT devices. A data source could also be any PLC which shall communicate with the easYview.



Atvise connect Restrictions:

Additional to the License restrictions, Atvise connect is limited to a maximum of three active data protocol connections and up to 1500 data points.

A data protocol connection is for example a Modbus TCP connection to an easYgen-3000XT.

A data point is for example a prepared Modbus address inside a Modbus protocol.

This means it is possible to have either three active easYgen-3000XT connections (Modbus TCP) or three active LS6-XT connections (Modbus TCP) or a combination like two active easYgen-3000XT connections (Modbus TCP) and one active LS6-XT connection (Modbus TCP), for instance.

6 Trouble Shooting

CAUTION!



Access Hierarchy

Please be aware that an easYgen-3000XT or LS-6XT can be controlled and remotely controlled via HMI and several interfaces.

To avoid (remote) access conflicts take care for undisturbed access management **on your - customers - side!**

Description	Information	Corrective Action
display "dark" but blue LED "ON"	<i>fatal display error</i>	send to Woodward service partner
blue LED "OFF"	<i>no power</i>	check power connection
	<i>fatal device error</i>	send to Woodward service partner
no easYgen-3000XT or LS-6XT found in network (device list screen)	<i>wrong device IP address or subnet mask</i>	go to chapter ↪ Chapter 4.2
	<i>network connection failed</i>	check connections, routers, ...
	<i>wrong LAN socket at easYview</i>	use LAN A of easYview
	<i>no easYgen-3000XT or LS-6XT in the same network</i>	check easYgen-3000XT's or LS-6XT network connectivity
	<i>easYgen-3000XT or LS-6XT failed to connect via Ethernet A</i>	check easYgen-3000XT's or LS-6XT's network connectivity
	<i>two easYview devices with same IP address are used</i>	change one of the IP addresses
	<i>Ethernet network conflict</i>	check your network for any possible IP address conflicts or contact your network administrator
element blinks yellow in mini-SCADA page	<i>connection to device cannot be established</i>	<p>check your network for any possible IP address conflicts or contact your network administrator</p> <p>check IP address and Modbus Slave ID of connected easYgen-3000XT</p> <p>Modbus protocol of connected easYgen-3000XT must be 5016</p> <p>More than 3 active Modbus connections available. Check the Connection Page that in total only three devices are enabled (easYgen-3000XT or LS-6XT).</p> <p>more than five easYview devices have an active Modbus TCP connection to the same eaYgen-3000XT device.</p>
connection in Remote HMI pages works, but not in mini-SCADA pages	<i>connection to device cannot be established in mini-SCADA mode</i>	<p>check the Modbus Slave ID of connected easYgen-3000XT</p> <p>Modbus protocol of connected easYgen-3000XT must be 5016</p> <p>more than five easYview devices have an active Modbus TCP connection to the same eaYgen-3000XT device.</p>

6 Trouble Shooting

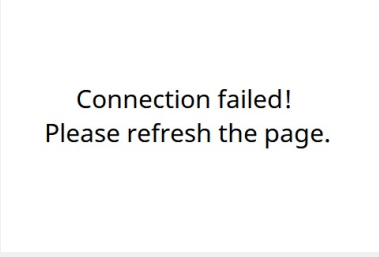
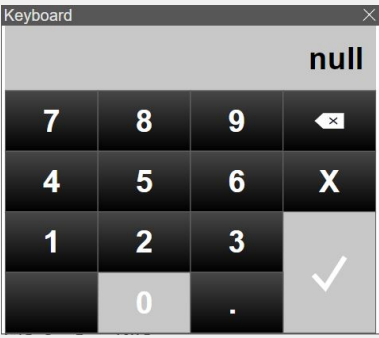
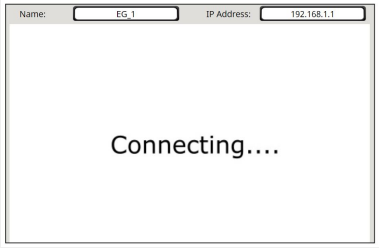
Description	Information	Corrective Action
<i>connection in Remote HMI has already worked, but now is interrupted and "Connecting..." is shown</i>	<i>pages on the easYgen have been browsed back and forth with very high frequency</i>	browse back and forth in a moderate way
<i>in Remote HMI screen the following message is shown:</i> 	<i>on two easYview devices a Remote HMI screen was launched at the same time.</i>	refresh the page or select the device again from device list.
<i>window "CCD exceeded!" pops up on PC</i>	<i>the mini-SCADA visualization is opened additional on a PC browser in parallel and too many data points (called CCD) are shown in total (easYview and PC browser).</i>	switch to "PC mode" page in the remote panel and refresh the web browser on the PC or close and reopen the browser on the PC
<i>window "CCD exceeded!" pops up on the Remote panel</i>	<i>the mini-SCADA visualization is opened additional on a PC browser in parallel and too many data points (called CCD) are shown in total (easYview and PC browser).</i>	switch to "PC mode" page in the PC or close the web browser on the PC switch pages on easYview if this has not solved the problem: reboot the easYview while web browser on the PC is closed
<i>settings in remote device (Remote HMI screen) cannot be found or even changed</i>	<i>wrong password level</i>	change password level. See password chapter in the easYgen-3000XT or LS-6XT Technical Manual.
<i>after boot up the easYview device shows "Loading..." for long time and is not switching to the MultiDevice page.</i>	<i>atvise server could not be started</i>	reboot easYview again
	<i>instead of actual value, "null" is shown on any keyboard pop-up window</i>	wait if page is fully loaded before changing values. Refresh page.
<i>Remote HMI screen is trying to connect permanently.</i> 	<i>easYgen-3000XT or LS6-XT has wrong IP address or has already a active Remote HMI connection.</i>	check IP address of easYgen-3000XT or LS6-XT. check if another easYview has already a VNC connection to that easYgen-3000XT or LS6-XT.
<i>visualization page is freezing</i>	<i>too fast interaction on touch panel</i>	refresh page by click on Woodward Logo or reboot easYview

7 Third Party Software

The easYview device uses the following third party software:

Name and Version of Software	Weblink	Remark
atvise builder 3.9.1	https://www.atvise.com	
atvise connect 2.6.7	https://www.atvise.com	
debian.11.6	https://hub.docker.com/_/debian	
python3 pip packets (wheels) <ul style="list-style-type: none"> • pycparser-2.21 • cryptography-39.0.1 • cffi-1.15.1 	https://pypi.org	
WebVNCServer <ul style="list-style-type: none"> • LibVNC v0.9.13 (GPL) • GNU cpp libs 	https://libvnc.github.io https://gcc.gnu.org	GPL code is published on Woodward Webpage
DeviceScanner (Woodward source code) <ul style="list-style-type: none"> • GNU cpp libs 	https://gcc.gnu.org	
Software installed on Advantech panel	https://www.advantech.com	
NotoSans font	https://fonts.google.com/noto/specimen/Noto+Sans	

Table 9: Third party software

8 Technical Specifications

8.1 Technical Data

Product label

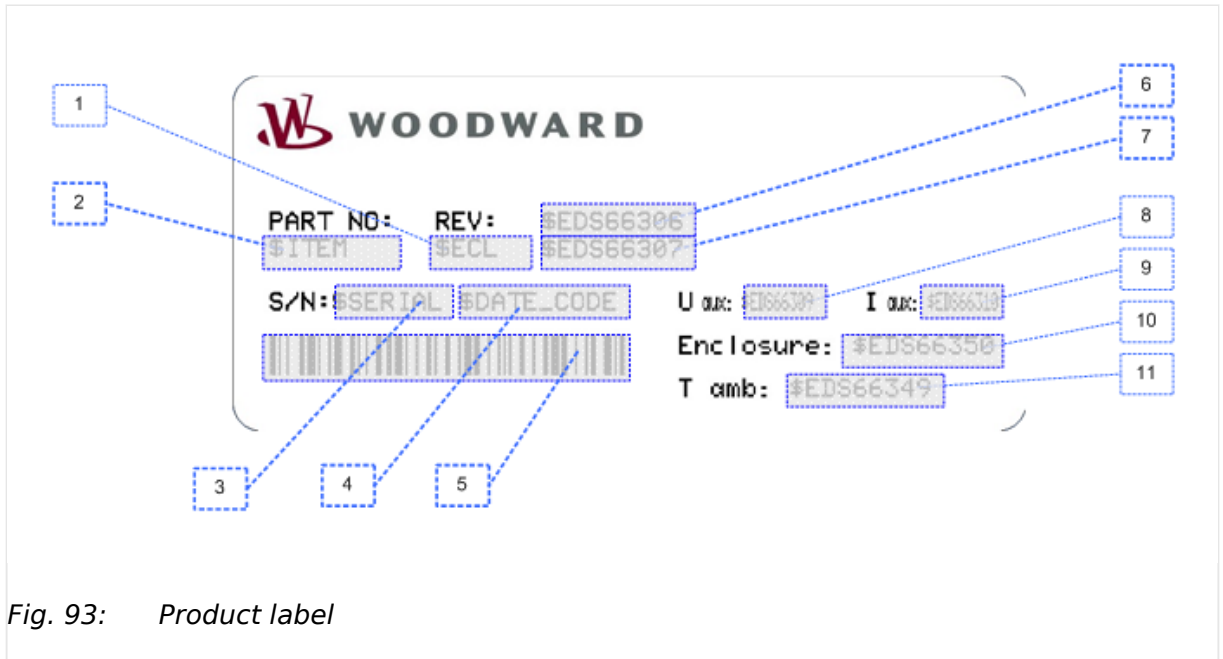

Fig. 93: Product label

1	REV	Item revision number
2	P/N	Item number
3	S/N	Serial number (numerical)
4	S/N	Date of production (year-month)
5	S/N	Serial number (barcode)
6	Type	Description (name)
7	Type	Description (type)
8 .. 11	Details	Technical data

8.1.1 Ambient Variables

Power supply	24 Vdc \pm 20%
Intrinsic consumption	7": typical 6 W, max. 9 W 10": typical 10 W, max. 12 W 15": typical 13 W, max. 16 W
Operating temperature	-20 to 60 °C (-4 to 140 °F)
Storage temperature	-30 to 70 °C (-22 to 158 °F)

Humidity	95% RH@40 °C, non-condensing
----------	------------------------------

8.1.2 System Hardware

CPU	NXP™ ARM Cortex™-A53 i.MX 8M Mini quad-core 1.6 GHz processor
Backup Memory	FRAM 1 MB
Memory	2 GB DDR4 RAM
Storage	16 GB eMMC onboard
Power-On LED bar	blue

8.1.3 Display

7" Panel

Display Type	WSVGA TFT LCD
Display Size	7"
Max. Resolution	1024 x 600
Max. Colors	16.7M
Luminance (cd/m ²)	425
Viewing Angle (H/V)	170/170
Backlight Life	LED; 50,000 h
Dimming	adjustable
Contrast Ratio	800:1

10" Panel

Display Type	WXGA TFT LCD
Display Size	10.1"
Max. Resolution	1280 x 800
Max. Colors	16.2M
Luminance (cd/m ²)	500
Viewing Angle (H/V)	170/170
Backlight Life	LED; 50,000 h
Dimming	adjustable

8 Technical Specifications

8.1.4 Touch Screen

Contrast Ratio	800:1
----------------	-------

15" Panel

Display Type	FHD TFT LCD
Display Size	15.6"
Max. Resolution	1920 x 1080
Max. Colors	16.2M
Luminance (cd/m ²)	450
Viewing Angle (H/V)	170/170
Backlight Life	LED; 50,000 h
Dimming	adjustable
Contrast Ratio	800:1

8.1.4 Touch Screen

Touch points	10 points
Light	Transmission above 85%
Pencil Hardness	7H
Type	Projected capacitive (P-CAP) touch

8.1.5 Interface***Ethernet LAN A only***

The other available interfaces are NOT to be USED for this application!

Ethernet interface

Ethernet LAN A (RJ45)	10/100/1000 Mbps LAN
Ethernet LAN B (RJ45)	NOT to be USED for this application!

Serial interface

RS-232/422/485 (COM 1)	NOT to be USED for this application!
------------------------	--------------------------------------

selectable mode for RS-485 and CAN 2.0B (COM 2)	NOT to be USED for this application!
---	--------------------------------------

USB interface

2 x USB 2.0 Type-A Host	NOT to be USED for this application!
-------------------------	--------------------------------------

Others

M.2 Key-E 2230 (Wi-Fi/BT)	NOT to be USED for this application!
---------------------------	--------------------------------------

8.1.6 Software

Operating System	Linux Yocto 3.3 with adaptations for Woodward
Woodward easYview software	Auto-start software to connect to multiple devices and to an easYgen-3000XT or LS-6XT for remote control via Ethernet . ©Woodward

**Other software**

For a detailed overview of all used software see chapter [↪ “7 Third Party Software”](#).

8.1.7 Housing**Housing type 7" Panel**

Dimensions (W × H × D)	205 × 146.92 × 52 mm
Front cutout (W × H)	192.4 × 139.0 mm
Recommended locked torque (provided mounting kit)	4 inch pounds / 0.5 Nm
Weight	approx. 2 kg

Housing type 10" Panel

Dimensions (W × H × D)	283.1 × 202.3 × 52 mm
Front cutout (W × H)	274.1 × 193.3 mm

8 Technical Specifications

8.1.8 Approvals

Recommended locked torque (provided mounting kit)	4 inch pounds / 0.5 Nm
Weight	approx. 3.9 kg

Housing type 15" Panel

Dimensions (W × H × D)	419.7 × 269 × 52 mm
Front cutout (W × H)	411.9 × 261.2 mm
Recommended locked torque (provided mounting kit)	4 inch pounds / 0.5 Nm
Weight	approx. 6.9 kg

Protection

Ingress protection	IP66 in the front with clamp fasteners
Vibration protection	Operating, random vibration 2 Grms (5 to 500 Hz)

8.1.8 Approvals

Industrial Control Equipment	UL certification
EMC test	CE, FCC Class B, BSMI
Listings	CE; BSML, CCC, UL, FCC Class A: 

8.1.9 Generic Note

Accuracy	Referred to remotely controlled device
----------	--

9 Glossary And List Of Abbreviations

CCD	Concurrent Connected Data variable (data variable that gets displayed in the visualization)
CL	Code Level
f	frequency
I	Current
mini-SCADA	Configurable multi device or plant visualization
Modbus	Communication Protocol
P	Real power
P/N	Part Number
PLC	Programmable Logic Control
Q	Reactive power
Remote HMI	HMI screen of external device like easYgen-XT or LS6-XT
S	Apparent power
S/N	Serial Number
V	Voltage

Index

C

Contact person	12
Customer Service	12

D

Dimensions	20
------------------	----

E

Ethernet Interface	28
Ethernet Topology	30

H

Hardware Interfaces	19
---------------------------	----

P

Panel configuration	39
Password	54
Personnel	12

S

Scope of delivery	4
Service	12
Symbols	
in the instructions	10

V

Version	68, 80
---------------	--------

W

Warranty	12
----------------	----



Woodward GmbH
Handwerkstraße 29 — 70565 Stuttgart — Germany
Phone +49 (0) 711 789 54-510
Fax +49 (0) 711 789 54-101
marketing_pg@woodward.com