



Application Note 51592
(Revision A, 1/2019)
Original Instructions

**Using RTCnet and LinkNet HT
with MicroNet Plus and MicroNet TMR**

Application Note



General Precautions

Read this entire manual and all other publications pertaining to the work to be performed before installing, operating, or servicing this equipment.

Practice all plant and safety instructions and precautions.

Failure to follow instructions can cause personal injury and/or property damage.



Revisions

This publication may have been revised or updated since this copy was produced. To verify that you have the latest revision, check manual **26455**, *Customer Publication Cross Reference and Revision Status & Distribution Restrictions*, on the *publications* page of the Woodward website:

www.woodward.com/publications

The latest version of most publications is available on the *publications* page. If your publication is not there, please contact your customer service representative to get the latest copy.



Proper Use

Any unauthorized modifications to or use of this equipment outside its specified mechanical, electrical, or other operating limits may cause personal injury and/or property damage, including damage to the equipment. Any such unauthorized modifications: (i) constitute "misuse" and/or "negligence" within the meaning of the product warranty thereby excluding warranty coverage for any resulting damage, and (ii) invalidate product certifications or listings.



Translated Publications

If the cover of this publication states "Translation of the Original Instructions" please note:

The original source of this publication may have been updated since this translation was made. Be sure to check manual **26455**, *Customer Publication Cross Reference and Revision Status & Distribution Restrictions*, to verify whether this translation is up to date. Out-of-date translations are marked with . Always compare with the original for technical specifications and for proper and safe installation and operation procedures.

Revisions— A bold, black line alongside the text identifies changes in this publication since the last revision.

Woodward reserves the right to update any portion of this publication at any time. Information provided by Woodward is believed to be correct and reliable. However, no responsibility is assumed by Woodward unless otherwise expressly undertaken.

Contents

ELECTROSTATIC DISCHARGE AWARENESS	3
CHAPTER 1. GENERAL INFORMATION.....	4
Introduction.....	4
Network Examples with MicroNet	4
CAN Network Design Guidelines	5
CAN Network Isolation & Architecture	5
CHAPTER 2. RTCNET NODE GAP IMPLEMENTATION	6
RTCnet Network Setup	6
RT_CAN_NTW Block.....	6
RTCnet Special Considerations	7
CHAPTER 3. LINKNET HT NODE GAP IMPLEMENTATION.....	8
LinkNet HT Network Setup.....	8
COPEN_NTW Block	8
LinkNet HT Behavior on CAN Network with Incorrect Baud Rate	9
Preventing Incorrect Baud on the Network	10
CHAPTER 4. LINKNET HT AND RTCNET BLOCKS	11
Other RTCnet and LinkNet HT Node Information	12
CHAPTER 5. RTN GATEWAY GAP IMPLEMENTATION.....	13
Network Communication	13
CHAPTER 6. LINKNET HT NODES - TMR IMPLEMENTATION.....	15
Network Configuration Options	15
Initialization of the CAN Networks.....	17
Failover/Switchover of the CAN Networks	19
Recommended GAP parameters.....	19

The following are trademarks of Woodward, Inc.:

GAP
LinkNet
MicroNet
RTCnet
Woodward

The following are trademarks of their respective companies:

Modbus (Schneider Automation Inc.)
Pentium (Intel Corporation)

Illustrations and Tables

Figure 1-1. Network Example with MicroNet.....	4
Figure 2-1. RTCnet Network Initialization	6
Figure 2-2. Accessing GAP RTCnet Message Map	7
Figure 3-1. LinkNet HT Network NODE_OP Logic	9
Figure 3-4. Baud Rate Configuration in GAP and on Nodes	10
Figure 4-1. Node Initialization Logic.....	11
Figure 5-1. RTN Gateway Network Reset Logic.....	13
Figure 5-2. GW_STAT	14
Figure 6-1. CAN Network Options for LinkNet HT Modules	15
Figure 6-2. Valid Signal and Module Selection	16
Figure 6-3. CAN initialization Using 2 Kernel CPU's	18
Figure 6-4. Health Check for Redundant CAN Ports	18
Table 3-1. Node Type Message Specifications	8

Electrostatic Discharge Awareness

NOTICE

Electrostatic Precautions

Electronic controls contain static-sensitive parts. Observe the following precautions to prevent damage to these parts:

- Discharge body static before handling the control (with power to the control turned off, contact a grounded surface and maintain contact while handling the control).
- Avoid all plastic, vinyl, and Styrofoam (except antistatic versions) around printed circuit boards.
- Do not touch the components or conductors on a printed circuit board with your hands or with conductive devices.

To prevent damage to electronic components caused by improper handling, read and observe the precautions in Woodward manual **82715**, *Guide for Handling and Protection of Electronic Controls, Printed Circuit Boards, and Modules*.

Follow these precautions when working with or near the control.

1. Avoid the build-up of static electricity on your body by not wearing clothing made of synthetic materials. Wear cotton or cotton-blend materials as much as possible because these do not store static electric charges as much as synthetics.
2. Do not remove the printed circuit board (PCB) from the control cabinet unless absolutely necessary. If you must remove the PCB from the control cabinet, follow these precautions:
 - Do not touch any part of the PCB except the edges.
 - Do not touch the electrical conductors, the connectors, or the components with conductive devices or with your hands.
 - When replacing a PCB, keep the new PCB in the plastic antistatic protective bag it comes in until you are ready to install it. Immediately after removing the old PCB from the control cabinet, place it in the antistatic protective bag.

Chapter 1.

General Information

Introduction

This application note describes lessons learned and best practices for using GAP to interface a MicroNet Plus to the following Woodward products: RTN Gateway, RTCnet I/O nodes, and LinkNet HT I/O nodes. These products allow system designers to remotely locate I/O in high temperature environments and expand the IO of a MicroNet Plus system. This document covers the setup of the communications with these products, as well as configuration, initialization, and communication.

The MicroNet TMR platform has been updated to support the use of LinkNet HT I/O nodes to expand the I/O of the system. Specific information for that implementation is given in Chapter 6.

This information is provided strictly as guidance. The system designer in combination with experience, regulatory requirements, and technical requirements should determine the applicability of this information.

Network Examples with MicroNet

The following is an example MicroNet Plus, redundant CPU system using RTCnet and LinkNet HT products. The MicroNet CPU's are directly connected to a group of RTCnet nodes and the RTN Gateway is used to interface with (2) other node groups.

This example shows redundant CPU's and multiple node locations supported with Woodward's RTN Gateway. It also shows redundant RTCnet CAN network wiring and redundant RTN networking to the RTN Gateway.

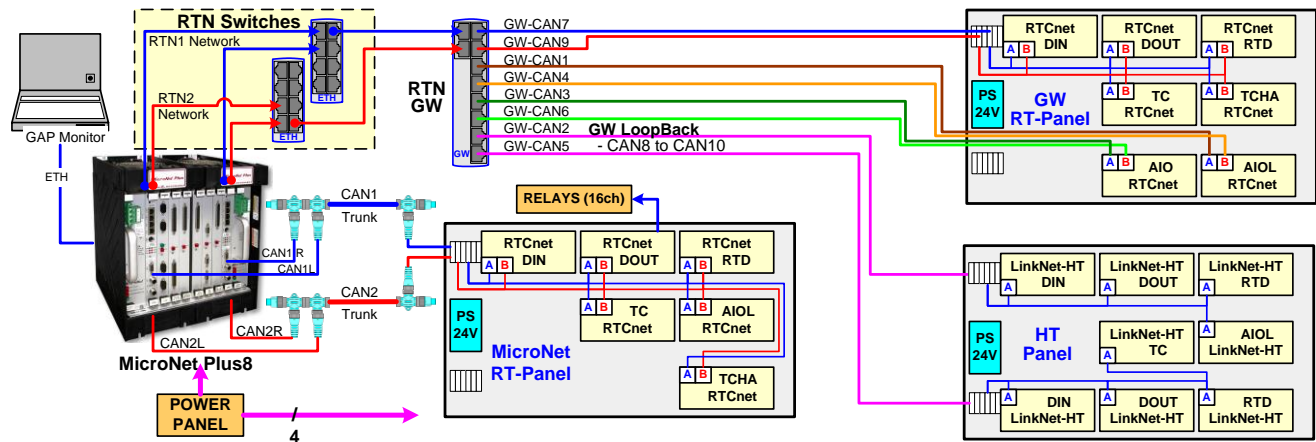

Figure 1-1. Network Example with MicroNet

IMPORTANT

Reference information:

- Manual 26640—For RTCnet and LinkNet HT nodes.
- Manual 26166—For MicroNet RTN Ethernet switches and cables.
- Manual 26612—For RTN Gateway information, cables, and setup.
- Manual 26167V1 – For MicroNet TMR Digital Control information

CAN Network Design Guidelines

RTCnet and LinkNet HT nodes communicate with the master controller (i.e. MicroNet) using the CAN protocol. Both RTCnet and LinkNet HT nodes support MicroNet dual CPU's and failover operation.

Note: RTCnet nodes have (2) redundant CAN ports and LinkNet HT nodes provide only (1) CAN port.

For details on cable specifications, please refer to manuals 26640 and 26166. A summary of CAN network limitations are listed below:

Max trunk length based on baud rate:

1 Mbps 30 m ("Thick" Cable)

500 Kbps 100 m

250 Kbps 250 m

125 Kbps 500 m

Max drop length for baud rates 125, 250, and 500 is 6 m. For baud rate 1 Mbps max drop length is 1 m.

Max cumulative drop based on baud rate:

1 Mbps 10 m

500 Kbps 20 m

250 Kbps 40 m

125 Kbps 80 m

Max trunk is reduced by the sum of the cumulative drops.

CAN Network Isolation & Architecture

Woodward recommends that each product type be placed on an independent CAN network. Therefore, RTCnet nodes should not be placed on the same network as LinkNet HT nodes. Similarly, RTCnet nodes should not be placed on the same network as valve drivers (DVP, VCP).

Chapter 2.

RTCnet Node GAP Implementation

RTCnet Network Setup

RTCnet networks are defined in GAP using the RT_CAN_NTW block. The node blocks (RTD, TC, AIO, DI, and DO) are children of the network block. The type of network block specifies the network type (RT network or CANopen network), since the same blocks are used for both LinkNet HT nodes and RTCnet nodes. The same logic can be used on a CPU CAN port or a RTN Gateway CAN port.

RT_CAN_NTW Block

This block is used to define a real time network using RTCnet nodes. The rate group of this block is set automatically based on the nodes connect to RT_DEV_n repeats. This network will automatically go to operational state after initialization.

CAN_BAUD: The baud rate (bits per second) is typically set based on distance of the CAN cable and number of nodes on the network. The baud rate set on this block must match the physical rotary switch of all the nodes attached to this network. It is recommended that this value be hardcoded based on the network length and number of nodes.

INIT_PERM: This input is a global tunable required to be set TRUE to allow the nodes to initialize when NTW_INIT is set TRUE.

NTW_INIT: This input triggers all nodes defined in the RT_DEV_n repeat to begin their configuration process if INIT_PERM is TRUE. This input should be driven by a power up reset (minimum three seconds), as well as the main reset if the network is offline. The recommended logic is shown below.

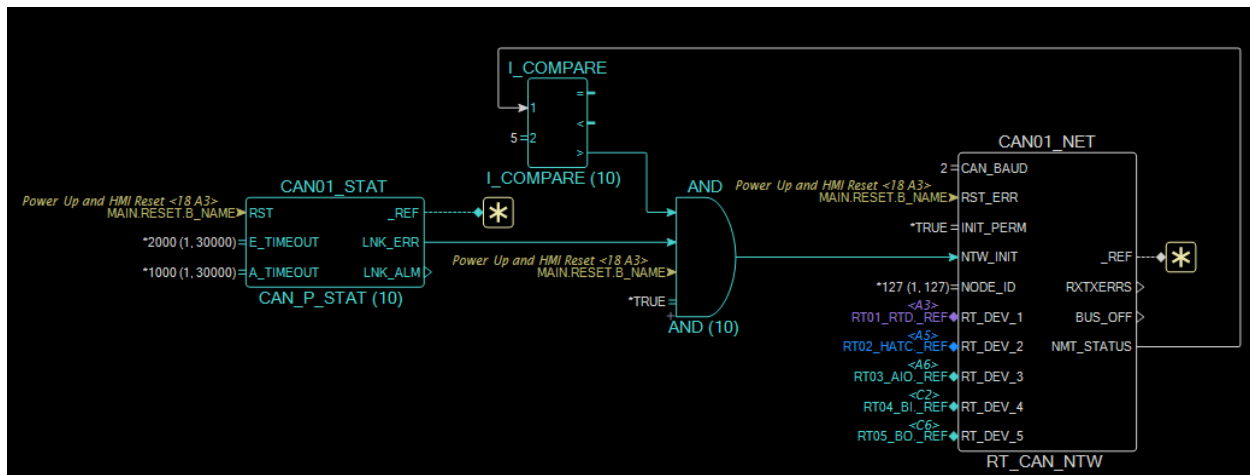

Figure 2-1. RTCnet Network Initialization

RTCnet Message Map: GAP provides a user interface to understand the messages on a RTC network. This can be accessed through the context menu of the RT_CAN_NTW block, as shown below.

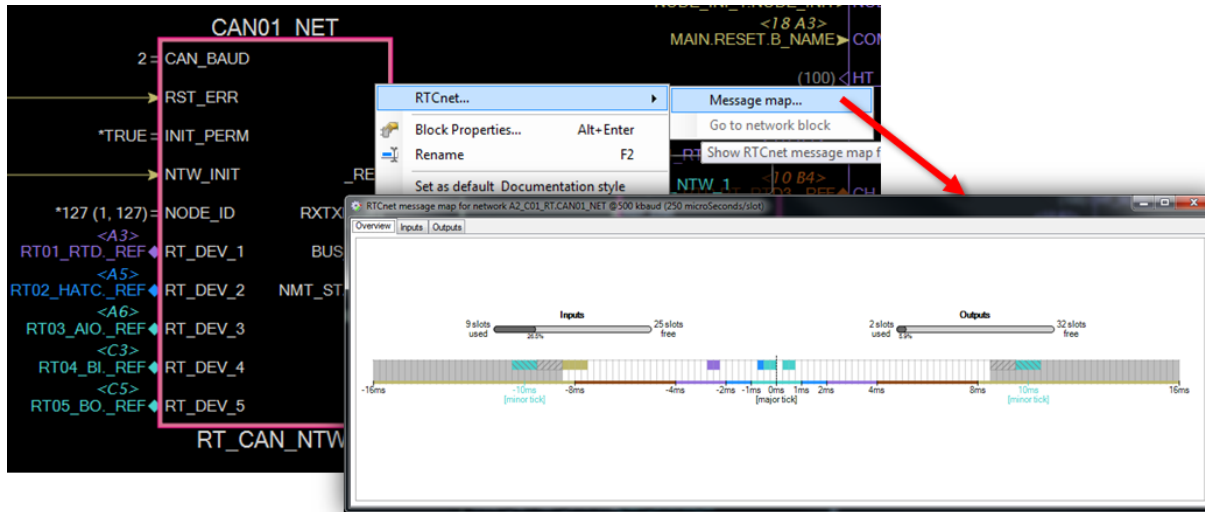

Figure 2-2. Accessing GAP RTCnet Message Map

RTCnet Special Considerations

- It is recommended to hardcode CAN Baud rate based on network design. This prevents the CPU attempting to communicate with the nodes at the incorrect baud rate, which can occur with a tunable baud rate.
- Disabling Readback Enable (RDBK_EN=FALSE) reduces network loading, but reduces diagnostic capabilities
- For analog input nodes, group the faster rate groups into the first four or last four channels. This consolidates the faster data into a single message.
- COMM_RST can be tied to generic alarm reset.
- The inputs INI_PERM and NODE_INIT control the initialization of the nodes. Initialization is used when the system powers on with a power up reset (minimum 3 seconds) and when a node is replaced. It is only necessary to initialize a node when it is not active. Please see Figure for example logic for these fields.

Chapter 3.

LinkNet HT Node GAP Implementation

LinkNet HT Network Setup

LinkNet HT networks are defined in GAP using the COPEN_NTW block. The node blocks (RTD, TC, AIO, DI, and DO) are children of the network block. The type of network block specifies the network type (RT network or CANopen network), since the same blocks are used for both LinkNet HT nodes and RTCnet nodes. The same logic can be used on a CPU CAN port or a RTN Gateway CAN port. The COPEN_NTW block is used for other CAN based products, including DVP and VCP. It is recommended that LinkNet HT nodes be placed on a dedicated network and not mixed with other CAN devices. For LinkNet HT networks, the COPEN_NTW block should be placed in the 20ms rate group.

COPEN_NTW Block

The COPEN_NTW block is used for CAN messaging on networks with a defined CanOpen protocol. The COPEN_NTW block defines a network image of messages available on a CAN port. One network image can be defined for each port in an application and assigned to an available CAN port. A network image can only be assigned to a single CAN port. This image will be enabled at application initialization time.

CAN_RST: This restarts the network when toggled TRUE by shutting down the interface and reinitializing it with the current settings—thus causing all nodes to reset. Do not tie this to alarm reset.

AUTOGO2OP: This input should be set FALSE for LinkNet HT and RTCnet networks.

RCV_BF_SZ: This is the First-in-First-Out (FIFO) buffer queue size for the network and is emptied at the rate of the fastest rate group of any child blocks. If this value is set too low, messages can be dropped. Therefore, the Receive Buffer Size should be set to a value larger than the number of expected messages to avoid the overrun. Though this can be set very high, CAN ports in RTN expansions such as MicroNet racks or Gateways can consume additional bandwidth. Depending on overall system size and load, this could be a problem on the very largest of applications. For LinkNet HT nodes count the number of input messages to the MicroNet per the node type. Add one slow diagnostic message per node. Set this receive buffer to this number of messages plus 20 percent round up for margin as rule of thumb.

Table 3-1. Node Type Message Specifications

Node Type	RTD	TC	AIO	DI	DO
Input Messages	2	2	2	1	1
Diagnostic	1	1	1	1	1
Readback if enabled	N/A	N/A	1	N/A	1
Total	3	3	4	2	3

HB_PDCR_RT: This input sets how frequently a heartbeat message is sent (in milliseconds). Set to zero for LinkNet HT and RTCnet networks.

NODE_OP: This is used for LinkNet HT and RTCnet networks to tell the MicroNet to go operational when set TRUE. The recommended logic for this input is shown below.

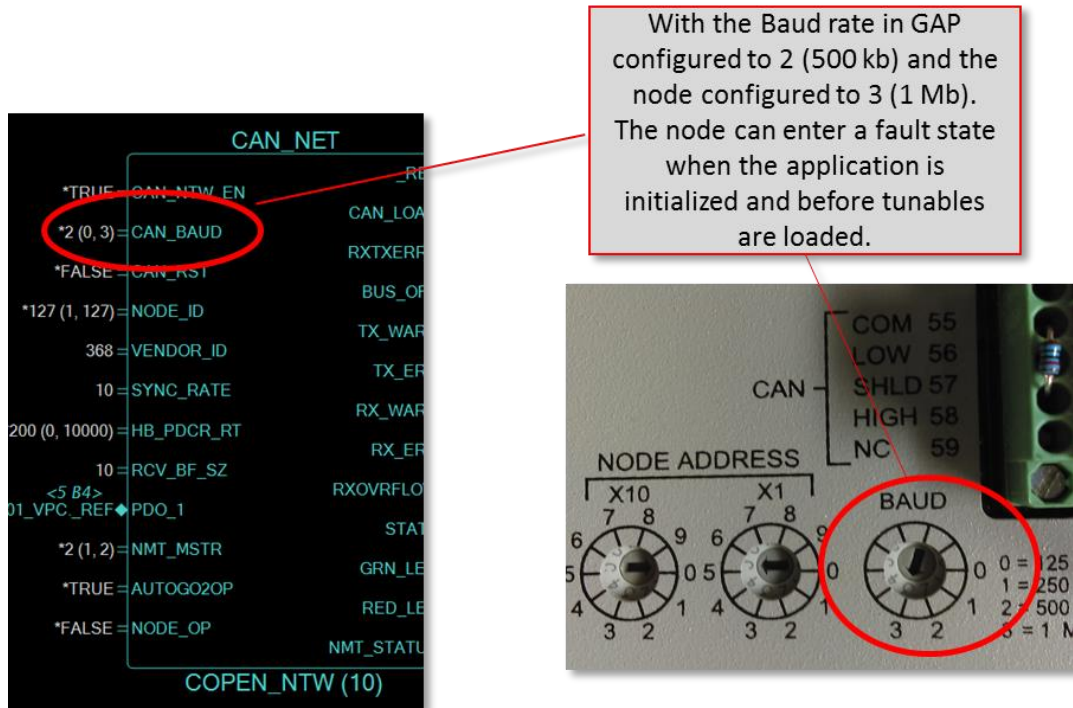

Figure 3-4. Baud Rate Configuration in GAP and on Nodes

Preventing Incorrect Baud on the Network

Since baud rate is dependent on the distance of the network and number of nodes, the baud rate is typically known when developing a GAP application. Therefore, Woodward recommends that the baud rate input be hardcoded to the value the network is designed to use. This will ensure that the control is initialized to the correct rate and LinkNet HT nodes do not enter a faulted state due to difference in baud rates.

In some applications, such as standard product applications a tunable value is required for user flexibility. The default value should be recommended in the product manual and the configuration logic of the application should restrict the tuning of this value to only be done when the control is in IOLOCK (Configure Mode). If it is changed while not in Configure Mode then the nodes rotary switch setting or nodes may need to be power cycled when the application code is changed and re-initialized.

Chapter 4.

LinkNet HT and RTCnet Blocks

The section below covers the inputs to the LinkNet GAP blocks that are used for both LinkNet HT and RTCnet nodes. The functionality and use of these inputs are provided based on experience using these blocks on gas turbine applications. The system designer in combination with experience, regulatory requirements, and technical requirements should determine the applicability of this information.

INIT_PERM: Allows the node to be initialized when set TRUE. INIT_PERM should be a *TRUE or if a Name block it should be in a rate group that is the same or faster as the network block. Keeping this *TRUE and protecting the NODE_INIT is another method to protect from accidental initialization.

NODE_INIT: This input is used to initialize the node when set TRUE. It is good to make this a tunable for easy node replacement and troubleshooting.

Once the GAP software runs it takes 8 to 10 seconds for the nodes to go operational and active, so during that time the inputs like temperature will fail high, analogs zero, DIs FALSE, in other words IO Lock failsafe state. If your logic is not desired to boot up this way, a software power up mask would be required.

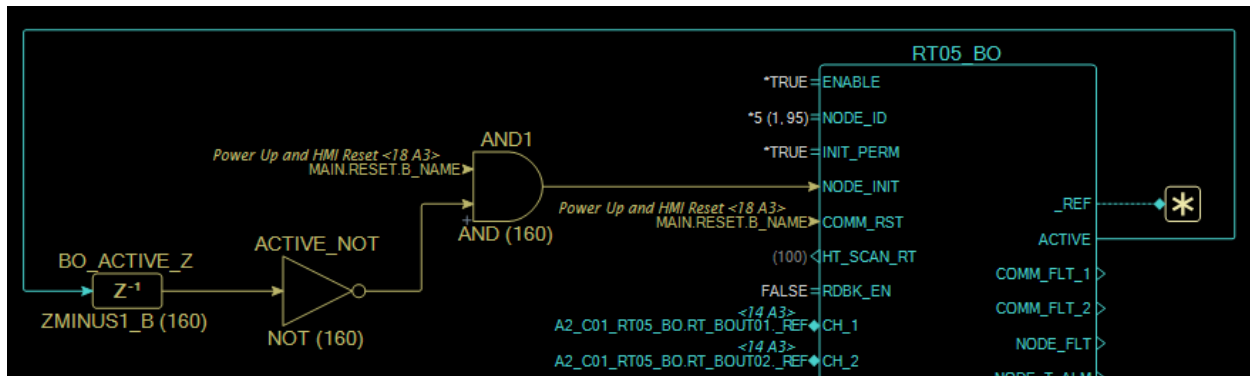

Figure 4-1. Node Initialization Logic

HT_SCAN_RT: This input only applies to LinkNet HT nodes. As a rule of thumb 100 HT nodes at 500 kBaud for 100 msec HT_SCAN_RT updates is available. Scaling the baud rate scales the number of nodes proportionally.

NODE_T_ALARM: Usually, a NODE_T_ALARM should not trigger a shutdown of the turbine, alarm only.

CFG_FAULT: The CFG_FAULT will go true when NODE_INIT is toggled. It will also go true upon boot up. If you want to avoid this for some reason, your logic will have to mask it. A shutdown may occur on CFG_FAULT and ID_FAULT if the site wants to, but a COMM_FLT will be present if these two have problems. Logical OR together COMM_FLT and NODE_FLT and NOT (ACTIVE) if you need this as a shutdown.

COMM_RST: This input can be tied to a generic alarm reset.

STANDBY: This input, when TRUE places the node into STANDBY mode which gives the ability to operate the LinkNet HT nodes (only) to be connected to more than one CAN network. The GAP help will provide additional details on how the node operates while in STANDBY mode.

Other RTCnet and LinkNet HT Node Information

Thermocouple Node: Use HA or High Accuracy TC version for on engine temperatures like T48 and T3 to meet topping limit accuracy requirements. Fail high also recommended for failsafe operation on these types of signals also.

AIO Node: Channel 6 is designed to be fast for PS3 stall detection to meet response requirements. Some compressor anti-surge signals as necessary can benefit from a faster (less hardware filtered) channel.

Node Stagger: On heavy HT networks stagger the ENABLE by 10 to 20 msec within the scan rate. This helps reduce CAN load during bootup.

Chapter 5.

RTN Gateway GAP Implementation

Network Communication

The RTN Gateway will establish communication to the MicroNet Plus CPU(s) automatically when the system is started in unison. If network communication is lost to the CPU in a simplex application or both CPU's in a redundant application, a RST_L_X must be given to the CPU(s). The application logic should prevent a RST_L_X command when communications to the RTN Gateway are healthy to any CPU. The application should also limit RST_L_X commands to once every 20-60 seconds to allow the system to reestablish communication. RST_R_X is not used for the RTN Gateway network.

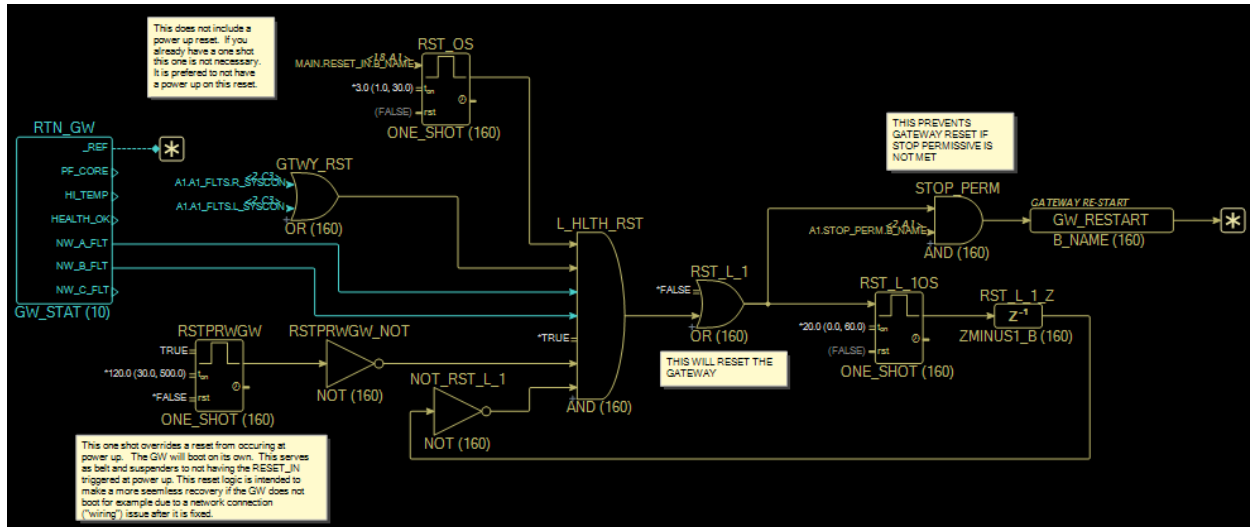

Figure 5-1. RTN Gateway Network Reset Logic

Gateway Status Notifications

When the RTN Gateway is used with redundant CPU's with Coder 6.xx the application should use ZMINUS1_B blocks on the output fields of GW_STAT and MODFLT_ATL to avoid erroneous indication on the backup CPU, as shown below. These ZMINUS1_B blocks are not needed in MicroNet Coder 1.00 and newer.

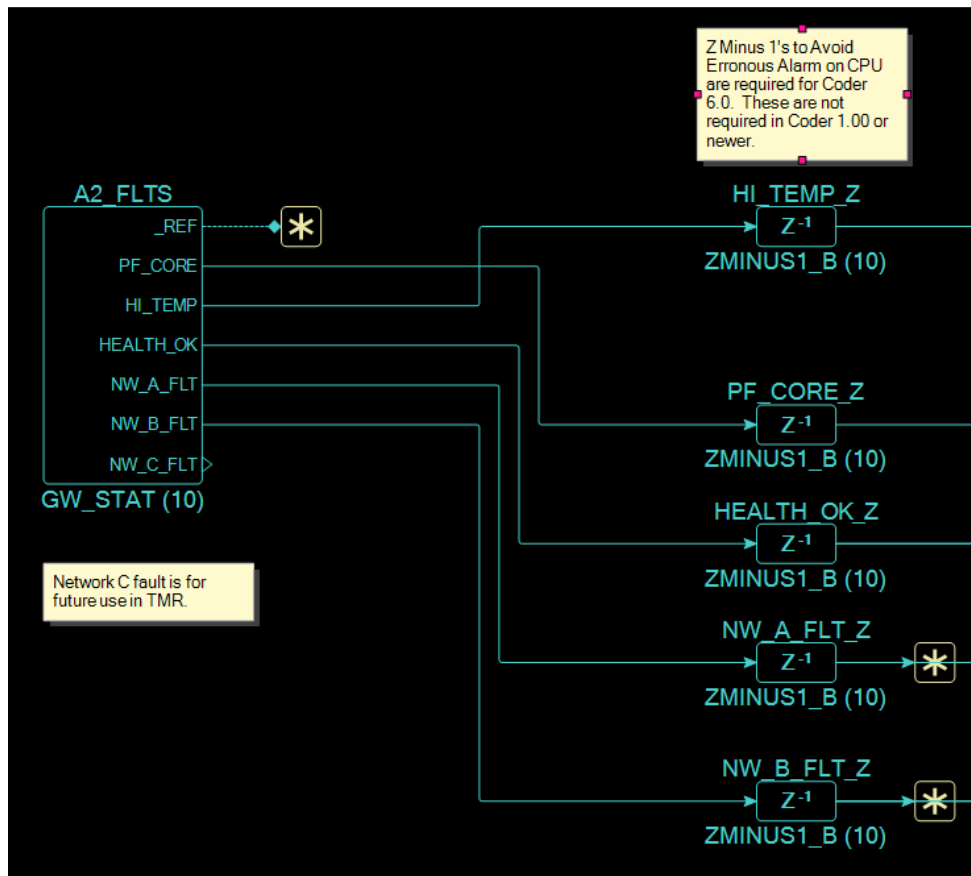

Figure 5-2. GW_STAT

Chapter 6.

LinkNet HT Nodes - TMR Implementation

The latest MicroNet TMR CPU and coder introduced CAN port functionality to this platform. In addition to the connectivity to Woodward's digital valve driver and power management products, the ability to interface to Woodward's LinkNet HT distributed I/O products are now available in the MicroNet TMR platform. This chapter will provide some details on how to successfully expand system I/O using LinkNet HT HT modules. The RTCnet modules are not supported in the TMR platform

Network Configuration Options

In TMR applications the programmer has three options for how to connect the LinkNet HT nodes to the main chassis. The first two are shown in the figure below.

1. A single CAN network of nodes that is connected to two CAN ports on two CPU's in the main chassis
2. Two isolated CAN networks of nodes that are each connected to only one CAN port in the main chassis. If redundancy of the LinkNet HT signals is required, this will require twice as many nodes
3. A single CAN network of nodes that is connected to one CAN port in the main chassis, this is a valid programming option, but is not recommended since the loss of the CPU connected to the CAN LinkNet HT nodes would result in those signals being lost to the entire GAP application

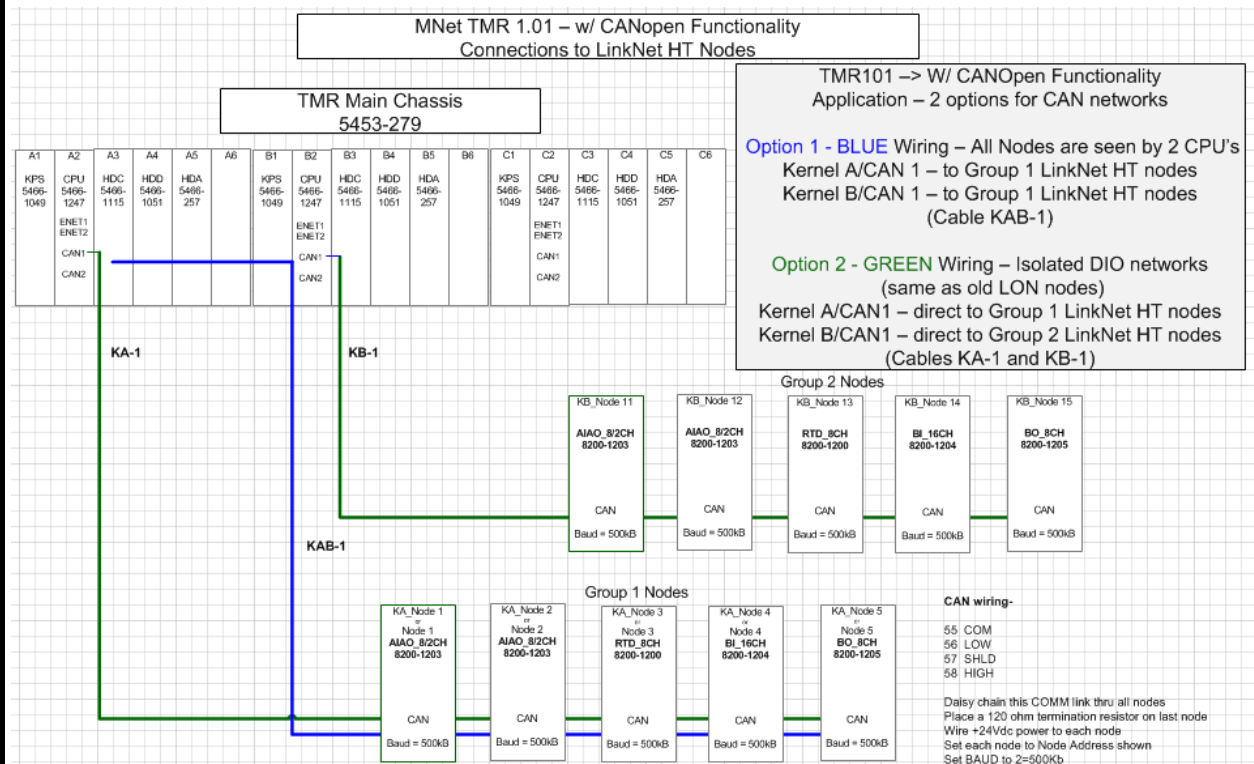

Figure 6-1. CAN Network Options for LinkNet HT Modules

For both options one and two, the GAP program will require two COPEN_NTW blocks to define the Distributed I/O network for each port, as described in Chapter 3 above. Application logic must be created to correctly select the valid input signals and annunciate channel and node fault conditions.

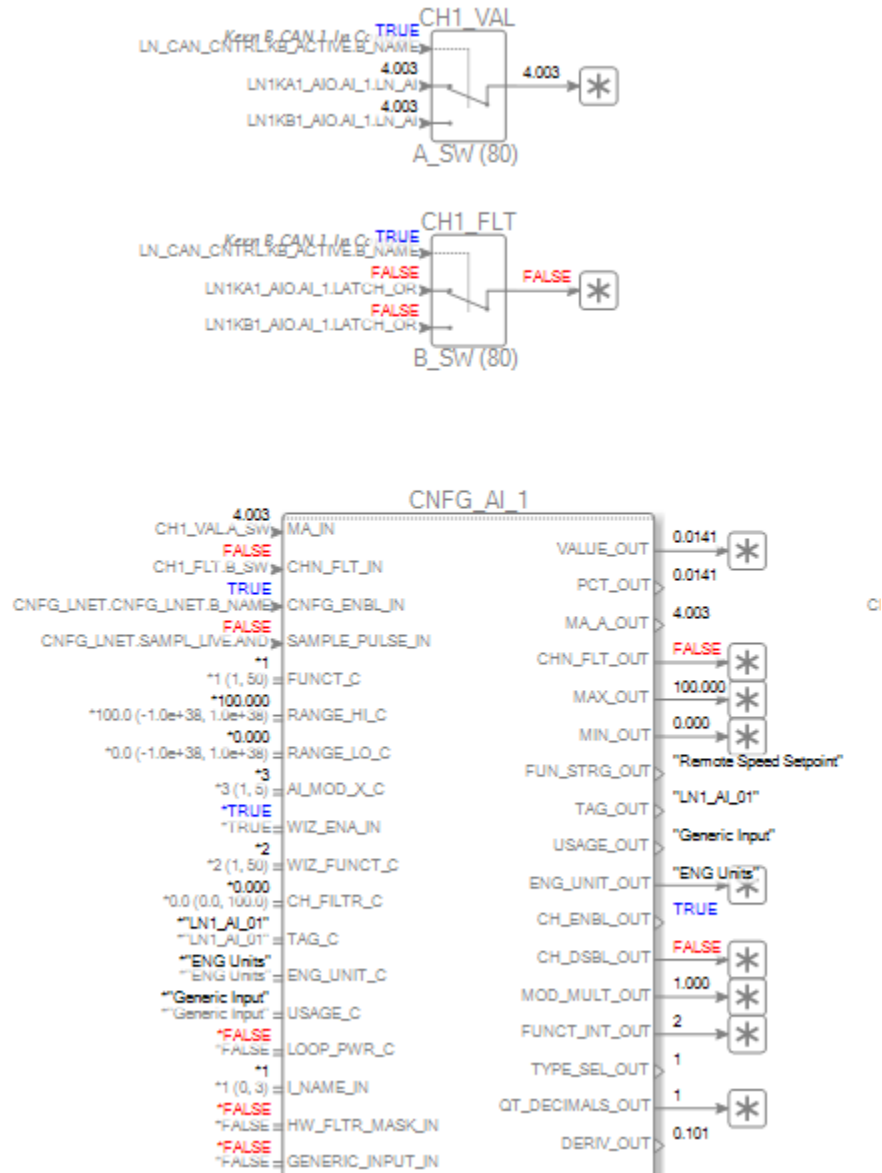

Figure 6-2. Valid Signal and Module Selection

If option two is used, then the selection of valid signals can be accomplished in the GAP the same way that any other redundant signals are handled. If option one is desired, then the following sections will provide guidance in how to design the GAP for correct operation.

Initialization of the CAN Networks

To achieve successful failover operation of the two CAN networks (COPEN_NTW blocks) on a common cable (option 1 above), both networks must be correctly initialized during the initial boot-up of the system.

To achieve this, a new input field (STANDBY) was added to each module block to allow the application to control which network was actively providing input data and controlling the outputs (ACTIVE output field status = TRUE) and which network was only reading data (STANDBY input field = TRUE).

The following is the required steps to initialize two 'paired' CAN networks in the GAP application:

1. Issue a CAN Reset (CAN_RST) to the first network (Kernel A / CAN port 1 in the example)
2. Verify that the CFG_FAULT output of all appropriate module blocks goes FALSE
3. Issue a Go to Operational command (pulse TRUE into NODE_OP input)
4. Verify that the NMT_STATUS output goes to a five
5. This network is now initialized and in control of the node outputs
6. Set the STANDBY input field on each module block in this network to TRUE to place this entire network into STANDBY mode (MSG_x_RATE outputs will continue to update)
7. Issue a CAN Reset (CAN_RST) to the second network (Kernel B / CAN port 1 in the example)
8. Verify that the CFG_FAULT output of all appropriate module blocks goes FALSE
9. Issue a Go to Operational command (pulse TRUE into NODE_OP input)
10. Verify that the NMT_STATUS output goes to a five
11. This network is now initialized and in control of the node outputs

Below is an example of an SFC state logic sheet created to visualize the initialization routine of two paired CAN networks that are connected to the same set of LinkNet HT nodes.

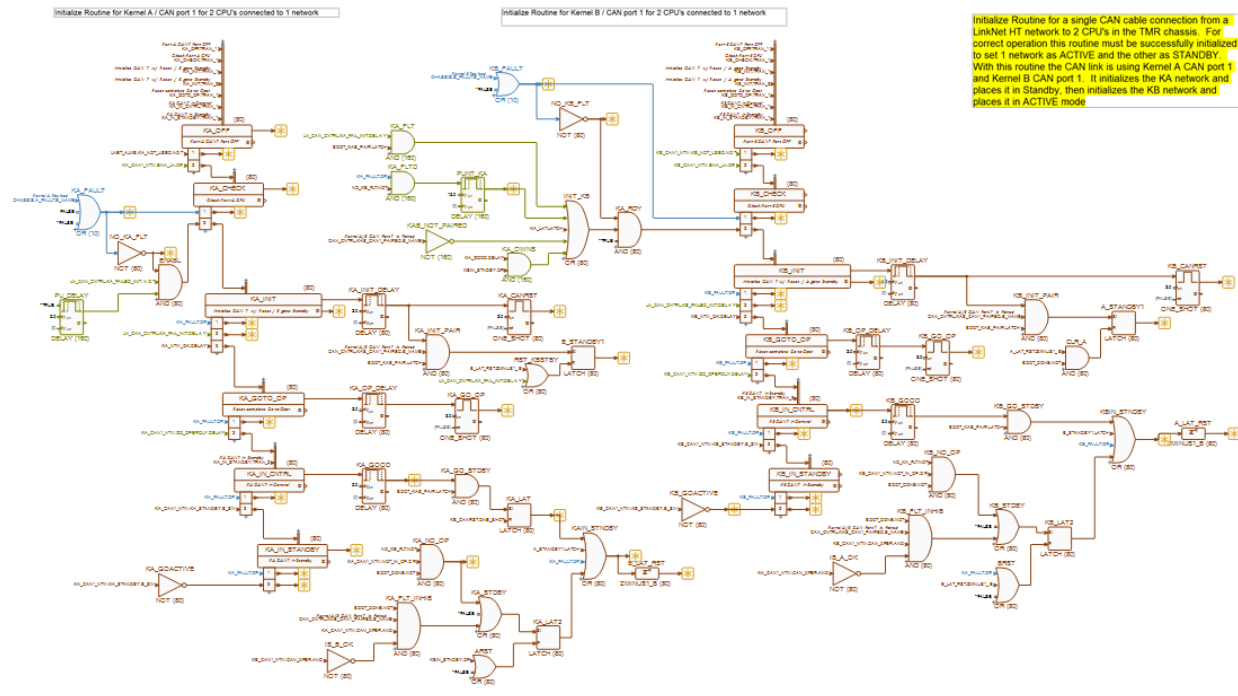

Figure 6-3. CAN initialization Using 2 Kernel CPU's

IMPORTANT Physical CAN cable connections to the nodes: The network will not initialize without an actual cable correctly connecting the CAN port to the LinkNet HT nodes.

It is recommended to create some clear indications for successful initialization that includes which CPU is in control and the health status of the other network.

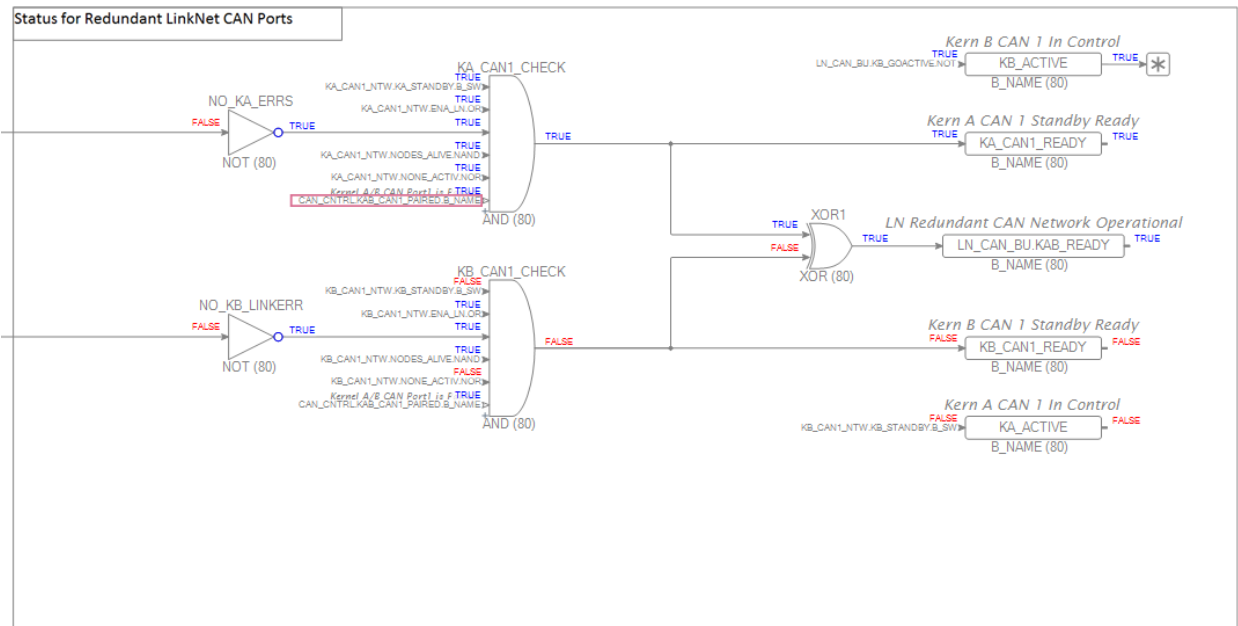

Figure 6-4. Health Check for Redundant CAN Ports

Failover/Switchover of the CAN Networks

The GAP application is responsible for controlling the STANDBY input field on both networks to provide successful operation due to system faults. For paired CAN ports, one network should always be ACTIVE, and have the input STANDBY=FALSE and the other should have STANDBY=TRUE. Logic should be designed so that when in normal operation, they are never both FALSE (no one in control) or both TRUE (both trying to control the output channels).

It is important to trigger a switchover whenever these conditions exist on the ACTIVE network.

- A Kernel CPU fault (CAN port) seen by the application (TCHAS_STAT.CPU_C_FLT)
- A CAN Port fault seen by the CAN_P_STAT.LNK_ALM block output
- The COPEN_NTW.NMT_STATUS output field going to something other than five (not operational)

NOTICE

STANDBY network status

It is recommended that all nodes on a network are either in STANDBY or ACTIVE mode. If the ACTIVE network is stopped (as would happen if CAN_RST was triggered), the STANDBY network will require application logic to take over during this event.

Recommended GAP parameters

The following are some recommended settings for typical LinkNet HT paired networks in TMR applications:

- Give the COPEN_NTW blocks different NODE_ID values
- Place all network, module and channel blocks and associated logic blocks in rate group 80
- Set the HT_SCAN_RT input field on each module block to be 100 ms
- Set the CAN_P_STAT E_TIMEOUT input to 300 ms
- Set the CAN_P_STAT A_TIMEOUT input to 200 ms
- Use the CAN_P_STAT.LNK_ALM output on the ACTIVE network to trigger a switchover to the STANDBY network

We appreciate your comments about the content of our publications.

Send comments to: icinfo@woodward.com

Please reference publication **51592**.



B 5 1 5 9 2 : -



PO Box 1519, Fort Collins CO 80522-1519, USA
1041 Woodward Way, Fort Collins CO 80524, USA
Phone +1 (970) 482-5811

Email and Website—www.woodward.com

Woodward has company-owned plants, subsidiaries, and branches, as well as authorized distributors and other authorized service and sales facilities throughout the world.

Complete address / phone / fax / email information for all locations is available on our website.