

## Dual DVP Installations

### Installation of CAN Network Identification Jumpers

#### *General Description of a Dual Positioner System*

This set of instructions is for Woodward dual DVP positioner systems for use with tandem actuators for control of the variable geometry systems of GE Heavy Duty Gas Turbines. This dual positioner, dual actuator system also supports control from dual CAN Open networks for precise digital control and diagnostics of the positioners and actuator system. For proper operation of this system, it is necessary to install a jumper terminal block within each positioner during initial installation. This terminal block configures each positioner for proper communication with its assigned primary or secondary CAN Open Network. The installation of this terminal block must be performed before attempting power-up or communications across the CAN Open Network. Until this process is complete, the positioners will not communicate with the networks. Please refer to Woodward product manual 26329 for additional information on installation, wiring, commissioning, and troubleshooting of the Woodward Digital Positioner.

Figure 1 shows a simplified diagram of the dual actuator and positioner system.

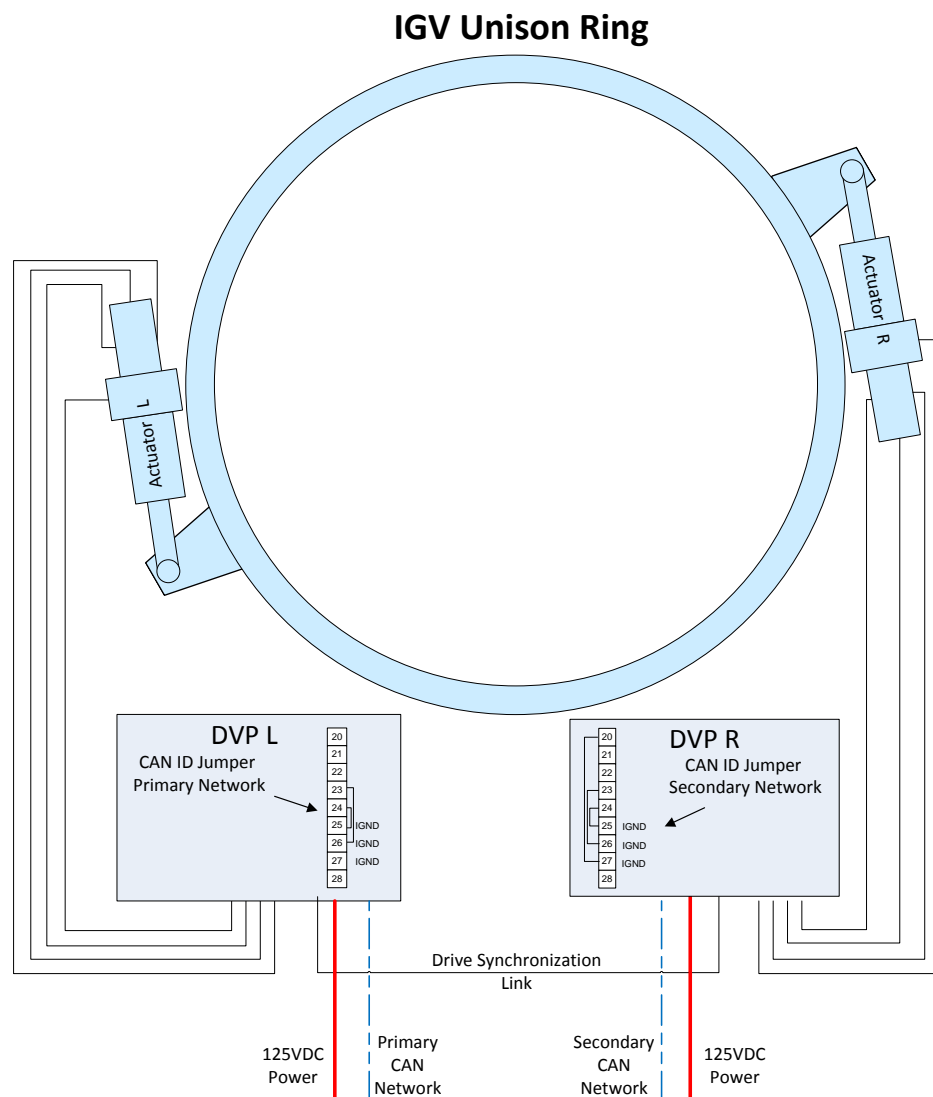

Figure 1. Dual Actuator and Positioner System Diagram

## Purpose of the CAN ID Jumper Terminal Blocks

To improve the availability of the system and in the event of a failure one of the CAN Open networks, each of the positioners used in the dual actuator system is connected to a separate CAN Open control network. One network is designated as the “Primary Network”; the other is designated as the “Secondary Network”. Under normal circumstances, the operating states (Run, Shutdown, and Reset) as well as the control messages (position setpoint, position feedback, diagnostics) are transmitted to both positioners via the primary network. The second positioner receives the primary operating states and control messages across the drive synchronization link such that both positioners operate on the exact same message stream.

In the event of primary CAN network failure, both positioners revert to the secondary CAN network data stream. Additionally, the drive synchronization link ensures both positioners operate with consistent information from the secondary network.

Both DVPs ship from the factory with identical configurations. Upon installation, it is necessary to assign which unit connects to the Primary CAN Open network and which connects to the Secondary CAN network. Complete this configuration by installing the appropriate CAN ID jumper terminal block within the DVPs.

**Note:** Incorrect installation of the jumper terminal blocks will result in incorrect operation of the units.

## Instructions for Installation of CAN ID Terminal Blocks

The following steps perform proper installation of the CAN ID Terminal Blocks:

- 1) Verify there is no power being applied to the DVPs.
- 2) Determine which DVP will be connected to the Primary CAN Network, and which will be connected to the Secondary CAN Network.
- 3) Identify the appropriate CAN ID Terminal Block associated with each CAN Network. The CAN ID Terminal blocks are labeled with their designated Network Number.

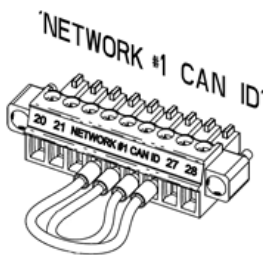

Figure 2. Network #1 CAN ID Terminal Block

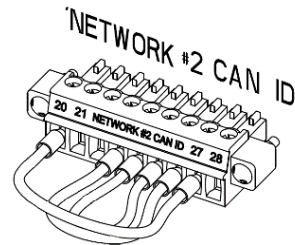

Figure 3. Network #2 CAN ID Terminal Block

After identifying the appropriate CAN ID Terminal Block, install it into the bottom row of the top printed **circuit board** of the DVP board stack (TB5-B as shown in Figure 4) with the #20 terminal position on the right.

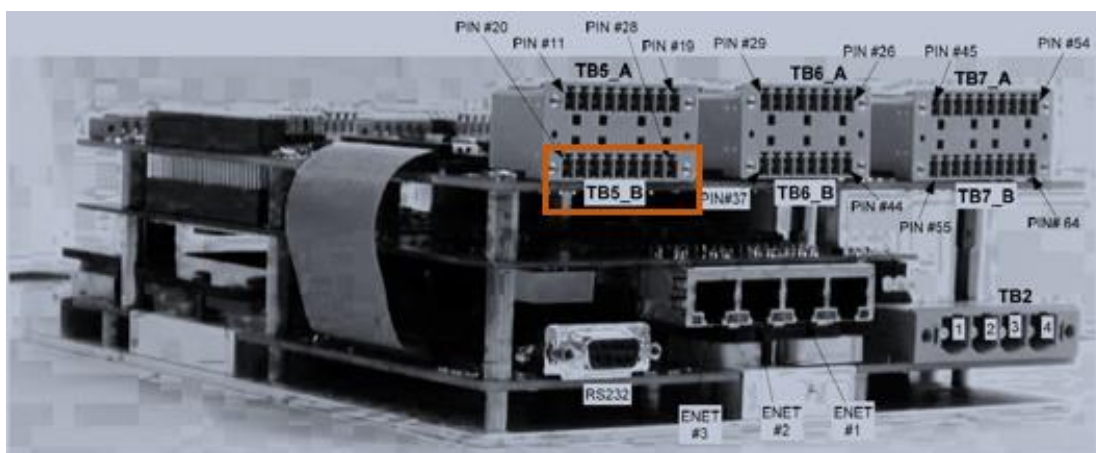

Figure 4. Installation Position for CAN ID Jumper

After installation of the jumper terminal blocks, tighten the retaining screws to 2.5 to 3.5 in-lb (0.3 to 0.4 N-m).

## Commissioning Checks

Continue wiring of the DVP Power, CAN Network Connections, and any discrete I/O as required by the application.

Connect all cables between the DVP and the actuator, verifying the connector locking rings are snug.

Verify all personnel are clear from the actuators and driven equipment. Complete any necessary local procedures or checks required by the plant or installation prior to applying power to the DVP's.

Power up the DVP and wait for the status LED to cycle from fast red/green (indicating Device Boot up) to a steady red flashing indicator. The steady flashing red indicator signals that boot up is complete. A flashing red indicator is normal as the system is awaiting a reset command prior to enabling operation.

Reset the DVP's. Test operation from both primary and secondary CAN Networks. Confirm that both networks are operational. If the status indication does not transition from a steady red flash to a steady green flash, refer to the DVP operating manual for troubleshooting information.

Once the status LED flashes a steady green display, the DVP reset has been successful. From the CAN network, send a setpoint value to the DVP. The actuators should begin tracking the setpoint.

Test operation from both the primary and secondary networks. If needed, refer to the control system and plant operating instructions for instructions on how to manually position the valves from the turbine control system.

## DVP Power Input Jumper

If a single power source is used to supply power to the DVP, jumpers should be used to apply power to both sets of input power terminals as shown in the left panel of Figure 5. The purpose of these jumpers is to ensure that the power supplied from the source is distributed equally to the two DVP inputs. This minimizes the power dissipated in each of the DVP input diodes for reduced heat load and improved reliability. When using the jumpers, insert the positive (+) power input lead from the power source into either the #1 or #3 positions, and the negative (-) lead into either the #2 or #4 positions. Use 12 AWG (3.31 mm<sup>2</sup>) jumpers from terminal position #1 to #3 and #2 to #4.

Some newer versions of the DVP 1.2 positioner include power input plugs with jumpers to connect the two positive and two negative terminals.

In installations where separate dual power sources are connected to the DVP as shown on the right panel of Figure 5, the jumpers are not required and should be removed before wiring to the power source.

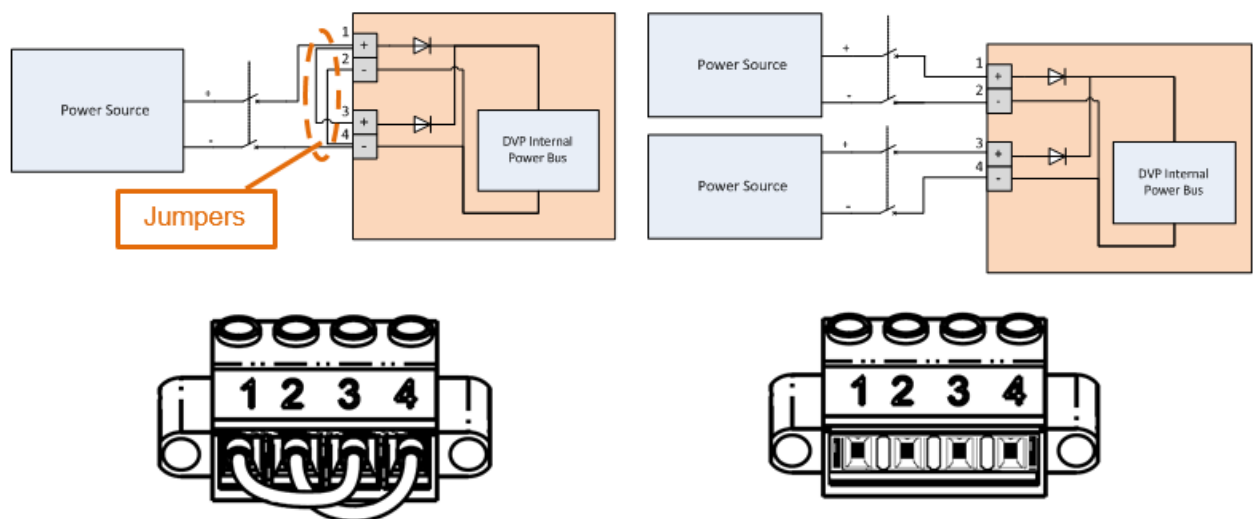

Figure 5. Jumpers for Power Input Plug

Copyright © Woodward, Inc. 2018  
All Rights Reserved



PO Box 1519, Fort Collins CO 80522-1519, USA  
1041 Woodward Way, Fort Collins CO 80524, USA  
Phone +1 (970) 482-5811

Email and Website—[www.woodward.com](http://www.woodward.com)

Woodward has company-owned plants, subsidiaries, and branches, as well as authorized distributors and other authorized service and sales facilities throughout the world.

Complete address / phone / fax / email information for all locations is available on our website.