

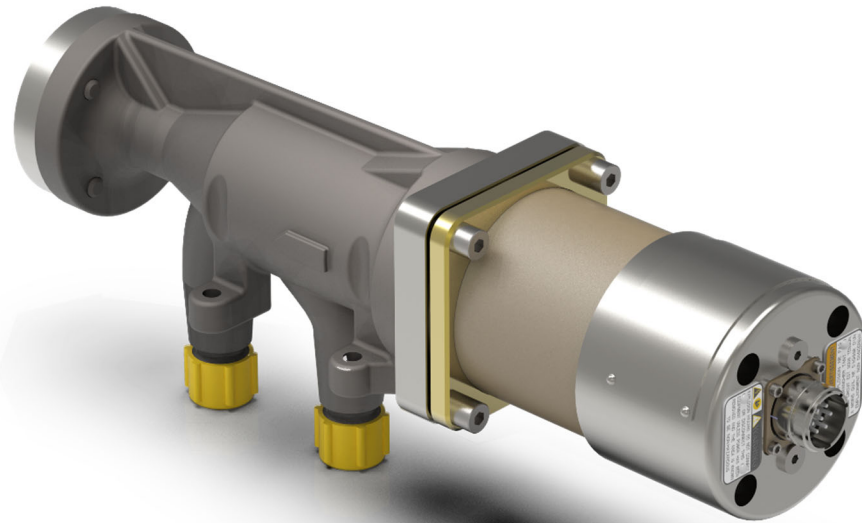

Product Manual 35182
(Revision -, 6/2022)
Original Instructions



Liquid Staging Valve

Installation and Operation Manual



General Precautions

Read this entire manual and all other publications pertaining to the work to be performed before installing, operating, or servicing this equipment.

Practice all plant and safety instructions and precautions.

Failure to follow instructions can cause personal injury and/or property damage.



Revisions

This publication may have been revised or updated since this copy was produced. To verify that you have the latest revision, check manual **26455**, *Customer Publication Cross Reference and Revision Status & Distribution Restrictions*, on the *publications page* of the Woodward website:

www.woodward.com/publications

The latest version of most publications is available on the *publications page*. If your publication is not there, please contact your customer service representative to get the latest copy.



Proper Use

Any unauthorized modifications to or use of this equipment outside its specified mechanical, electrical, or other operating limits may cause personal injury and/or property damage, including damage to the equipment. Any such unauthorized modifications: (i) constitute "misuse" and/or "negligence" within the meaning of the product warranty thereby excluding warranty coverage for any resulting damage, and (ii) invalidate product certifications or listings.



Translated Publications

If the cover of this publication states "Translation of the Original Instructions" please note:

The original source of this publication may have been updated since this translation was made. Be sure to check manual **26455**, *Customer Publication Cross Reference and Revision Status & Distribution Restrictions*, to verify whether this translation is up to date. Out-of-date translations are marked with . Always compare with the original for technical specifications and for proper and safe installation and operation procedures.

Revisions— A bold, black line alongside the text identifies changes in this publication since the last revision.

Woodward reserves the right to update any portion of this publication at any time. Information provided by Woodward is believed to be correct and reliable. However, no responsibility is assumed by Woodward unless otherwise expressly undertaken.

Contents

WARNINGS AND NOTICES	3
REGULATORY COMPLIANCE	4
CHAPTER 1. GENERAL INFORMATION	6
Information	6
CHAPTER 2. SPECIFICATIONS.....	7
CHAPTER 3. INSTALLATION	11
Receiving Instructions	11
Unpacking Instructions.....	11
Installation Instructions.....	11
CHAPTER 4. OPERATION.....	15
Operating the Liquid Staging Valve	15
Energizing and De-Energizing the Actuator.....	15
Valve Position Feedback.....	15
CHAPTER 5. REPAIR AND TROUBLESHOOTING.....	16
General.....	16
Return for Repair Instruction.....	16
Protective Packing	16
Hardware Replacement	16
Troubleshooting and Troubleshooting Guide.....	17
CHAPTER 6. PRODUCT SUPPORT AND SERVICE OPTIONS	19
Product Support Options.....	19
Product Service Options	19
Returning Equipment for Repair	20
Replacement Parts.....	21
Engineering Services	21
Contacting Woodward's Support Organization	21
Technical Assistance	22
CHAPTER 7. ASSET MANAGEMENT AND REFURBISHMENT SCHEDULING PERIOD	23
CHAPTER 8. LONG-TERM STORAGE REQUIREMENTS	24
APPENDIX COMMISSIONING CHECKLIST.....	25
REVISION HISTORY	26
DECLARATIONS	27

The following are trademarks of Woodward, Inc.:
Woodward

Illustrations and Tables

Figure 2-1. Hydraulic Schematic.....	8
Figure 2-2a. Liquid Staging Valve Outline Drawing	9
Figure 2-2b. Liquid Staging Valve Outline Drawing	10
Figure 3-1. Solenoid Electrical Schematic	13
Figure 3-2. Mating Cable Harness to Liquid Staging Valve	14
Table 2-1. Specifications.....	7
Table 3-1. Fastener Specifications	11
Table 5-1. Liquid Staging Valve Troubleshooting Guide	17

Warnings and Notices

Important Definitions



This is the safety alert symbol used to alert you to potential personal injury hazards. Obey all safety messages that follow this symbol to avoid possible injury or death.

- **DANGER** - Indicates a hazardous situation, which if not avoided, will result in death or serious injury.
- **WARNING** - Indicates a hazardous situation, which if not avoided, could result in death or serious injury.
- **CAUTION** - Indicates a hazardous situation, which if not avoided, could result in minor or moderate injury.
- **NOTICE** - Indicates a hazard that could result in property damage only (including damage to the control).
- **IMPORTANT** - Designates an operating tip or maintenance suggestion.

! WARNING	<p>The engine, turbine, or other type of prime mover should be equipped with an overspeed shutdown device to protect against runaway or damage to the prime mover with possible personal injury, loss of life, or property damage.</p>
<p>Overspeed / Overtemperature / Overpressure</p>	<p>The overspeed shutdown device must be totally independent of the prime mover control system. An overtemperature or overpressure shutdown device may also be needed for safety, as appropriate.</p>

! WARNING	<p>The products described in this publication may present risks that could lead to personal injury, loss of life, or property damage. Always wear the appropriate personal protective equipment (PPE) for the job at hand. Equipment that should be considered includes but is not limited to:</p>
<p>Personal Protective Equipment</p>	<ul style="list-style-type: none"> • Eye Protection • Hearing Protection • Hard Hat • Gloves • Safety Boots • Respirator <p>Always read the proper Material Safety Data Sheet (MSDS) for any working fluid(s) and comply with recommended safety equipment.</p>

! WARNING	<p>Be prepared to make an emergency shutdown when starting the engine, turbine, or other type of prime mover, to protect against runaway or overspeed with possible personal injury, loss of life, or property damage.</p>
<p>Start-up</p>	

Regulatory Compliance

European Compliance for CE Marking:

These listings are limited only to those units bearing the CE Marking.

ATEX Directive: Directive 2014/34/EU on the harmonisation of the laws of the Member States relating to equipment and protective systems intended for use in potentially explosive atmospheres.
Zone 2, Category 3, Group II G, Ex nA nC IIC T220°C Gc

Other European Compliance:

Compliance with the following European Directives or standards does not qualify this product for application of the CE Marking:

EMC Directive: Not applicable to this product. Electromagnetic, EMC, passive devices are excluded from the scope of the 2014/30/EU Directive

ATEX Directive: Exempt from the non-electrical portion of the ATEX Directive 2014/34/EU due to no potential ignition sources per EN ISO 80079-36:2016 for Zone 2 installation.

Machinery Directive: Compliant as partly completed machinery with Directive 2006/42/EC of the European Parliament and the Council of 17 May 2006 on machinery.

Pressure Equipment Directive: Compliant as "SEP" per Article 4.3 to Pressure Equipment Directive 2014/68/EU on the harmonisation of the laws of the Member States relating to making pressure equipment available on the market.

Other International Compliance:

IECEX (Staging Valve Actuator): Certified for use in explosive atmospheres per IECEX CSA 18.0043X.
Zone 2, Category 3, Group II G, Ex nA nC IIC T200°C Gc

North American Compliance:

These listings are limited only to those units bearing the CSA c-us identification.

CSA (Staging Valve Actuator): Certified for Class I, Div. 2, Groups A, B, C & D, 220 °C
For use in Canada and the United States.
Certificate 160584-70193369

Special Conditions for Safe Use:

Wiring must be in accordance with North American Class I, Division 2, or European or other international Zone 2 Category 3 wiring methods as applicable, and in accordance with the authority having jurisdiction.

Mating connector must be fully engaged to achieve IP54 rating of enclosure for ATEX and IECEX requirements.

The valve must be mounted to the support frame and the mounting bolts and fluid connections properly torqued.

Field wiring must be suitable for at least 150°C.

Compliance with the Machinery Directive 2006/42/EC noise measurement and mitigation requirements is the responsibility of the manufacturer of the machinery into which this product is incorporated.

 **WARNING****EXPLOSION HAZARD**

Do not remove covers or connect/disconnect electrical connectors unless power has been switched off or the area is known to be non-hazardous.

Substitution of components may impair suitability for Class I, Division 2, or Zone 2 applications.

 **AVERTISSEMENT****RISQUE D'EXPLOSION**

Ne pas enlever les couvercles, ni raccorder / débrancher les prises électriques, sans vous en assurez auparavant que le système a bien été mis hors tension; ou que vous situez bien dans une zone non explosive.

La substitution de composants peut rendre ce matériel inacceptable pour les emplacements de Classe I, applications Division 2 ou Zone 2.

Chapter 1.

General Information

Information

The Woodward Liquid Staging Valve is designed for use in GE LM series aeroderivative industrial liquid turbine engines. As its name implies, liquid staging valves provide the means to stage liquid fuel flow to the manifold rings on the engine combustor. Liquid staging valves allow ultimate control over fuel flow to a specific manifold ring or portion of a manifold ring to allow precise combustion control.

The liquid staging valve is also used as a liquid purge valve. In this application, it is used to drain and purge liquid fuel from the fuel rings, fuel nozzles, and pigtailed after running on liquid fuel.

The liquid staging valves are normally open, solenoid-operated on/off poppet valves with a position feedback switch integrated into the actuator. The position feedback switch provides the control system with the open/closed status of each Liquid staging valve.

The liquid staging valves are designed for fast and reliable operation and for operational longevity. All components used in the construction of the liquid staging valve are made from corrosion resistant materials to sustain for a long life.

The liquid staging valve is specifically designed to be interchangeable with existing applications, meeting tight flow tolerance requirements for reduced flow variation between valves. All electrical and fluid connections are compatible with existing applications.

Construction

The Woodward liquid staging valve is made up of the following major components:

1. Staging valve actuator— consisting of an electrically operated solenoid and position feedback switch
2. Liquid staging valve housing
3. Liquid staging valve poppet and seat

Solenoid and position feedback switch – designed and tested for high cycle life, force margin, long thermal life.

Liquid valve housing – designed and tested for high pressure and high cycle fatigue life.

Liquid valve poppet and seat – designed and tested for high cycle life and tight seat leakage.

Chapter 2. Specifications

Table 2-1. Specifications

Physical and Performance Specifications

Actuator Response Time:	< 150 ms
Failsafe Operation:	Valve open, actuated by an internal return spring
Weight:	9.4 kgf (21 lbf)
Mounting:	Axis horizontal, ports below axis

Environmental Specifications

Ambient Temperature:	-7 to 93°C (20 to 200°F) Normal -40 to 121°C (-40 to 250°F) Extreme
Vibration Resistance:	6 g's maximum, 5 to 2000 Hz
Shock Resistance:	5 G Peak, 10 ms duration
Corrosion Resistance:	All components designed from corrosion resistant materials
Ingress Protection (Actuator):	IP54 per IEC 60079-0/IEC 60529

Electrical Specifications

Actuator Rated Supply Voltage:	125 VDC ±10%
Actuator Current Consumption:	1.1 A maximum
Feedback Switch Supply Voltage:	10-32 VDC
Feedback Switch Supply Current:	100 mA maximum
Connection:	EN2997/M83723 Style, Shell size 14, 7-pin

Fluid Specifications

Process Fluid:	Liquid fuel approved for turbine firing (Diesel, Jet Fuel, etc.)
Fluid Temperature:	-29 to 66°C (-20 to 150°F)
Maximum Working Fluid Pressure:	9653 kPa (1400 psig) at maximum temperature
Proof Pressure:	12411 kPa (1800 psig) at maximum temperature
Burst Pressure:	16547 kPa (2400 psig) at maximum temperature
Valve Leakage Class:	Liquid: Class V per ANSI FCI 70-2 Purge: Class IV per ANSI FCI 70-2

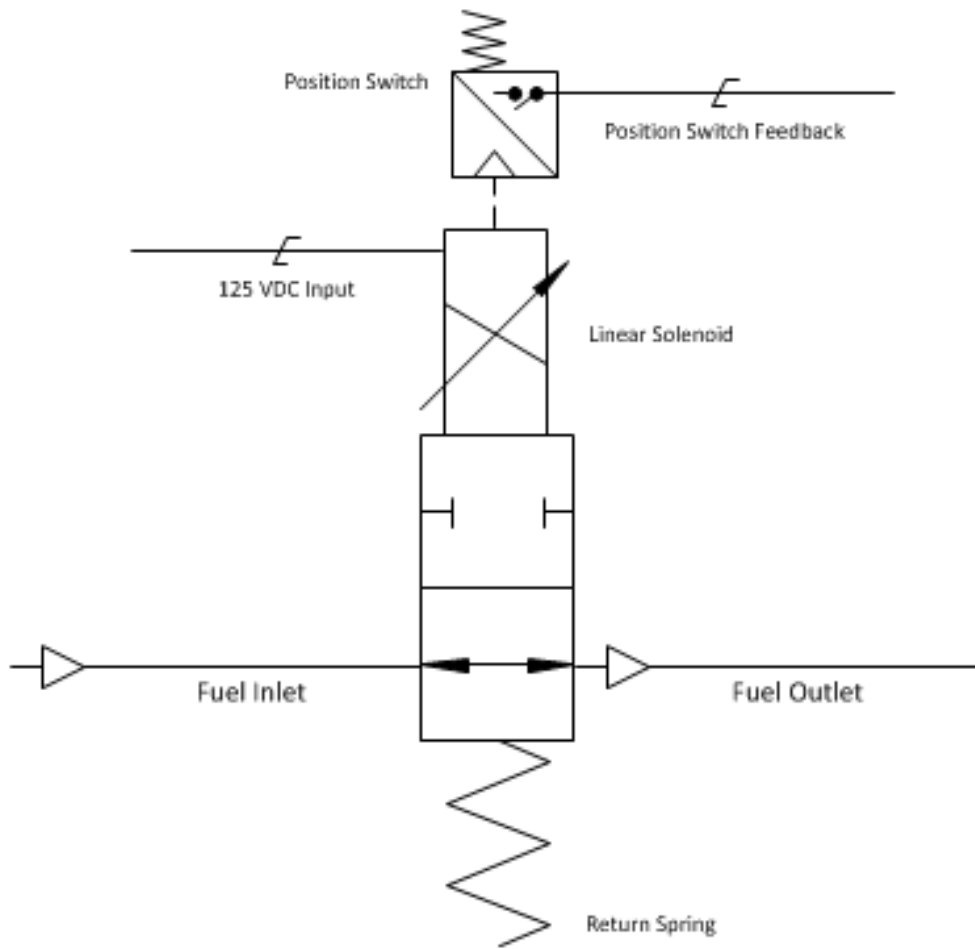

Figure 2-1. Hydraulic Schematic

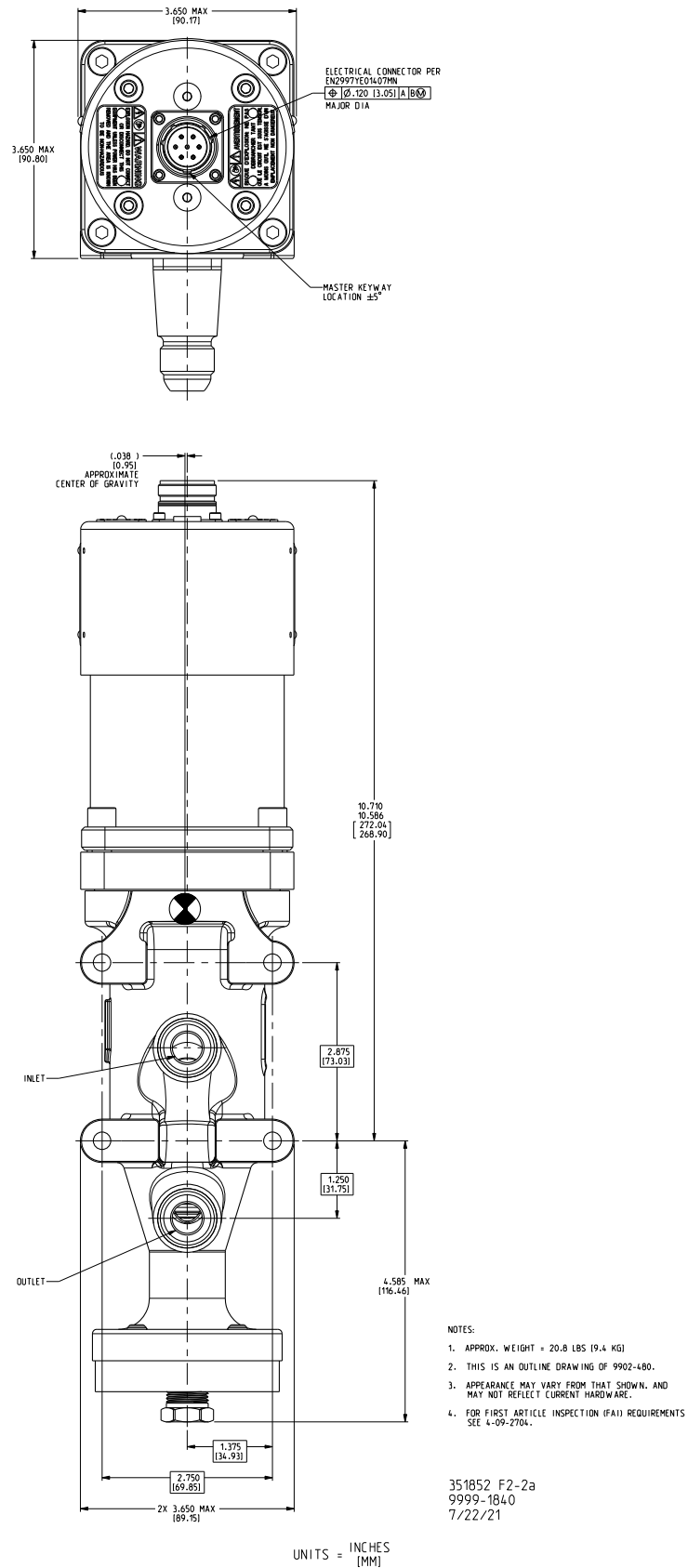

Figure 2-2a. Liquid Staging Valve Outline Drawing

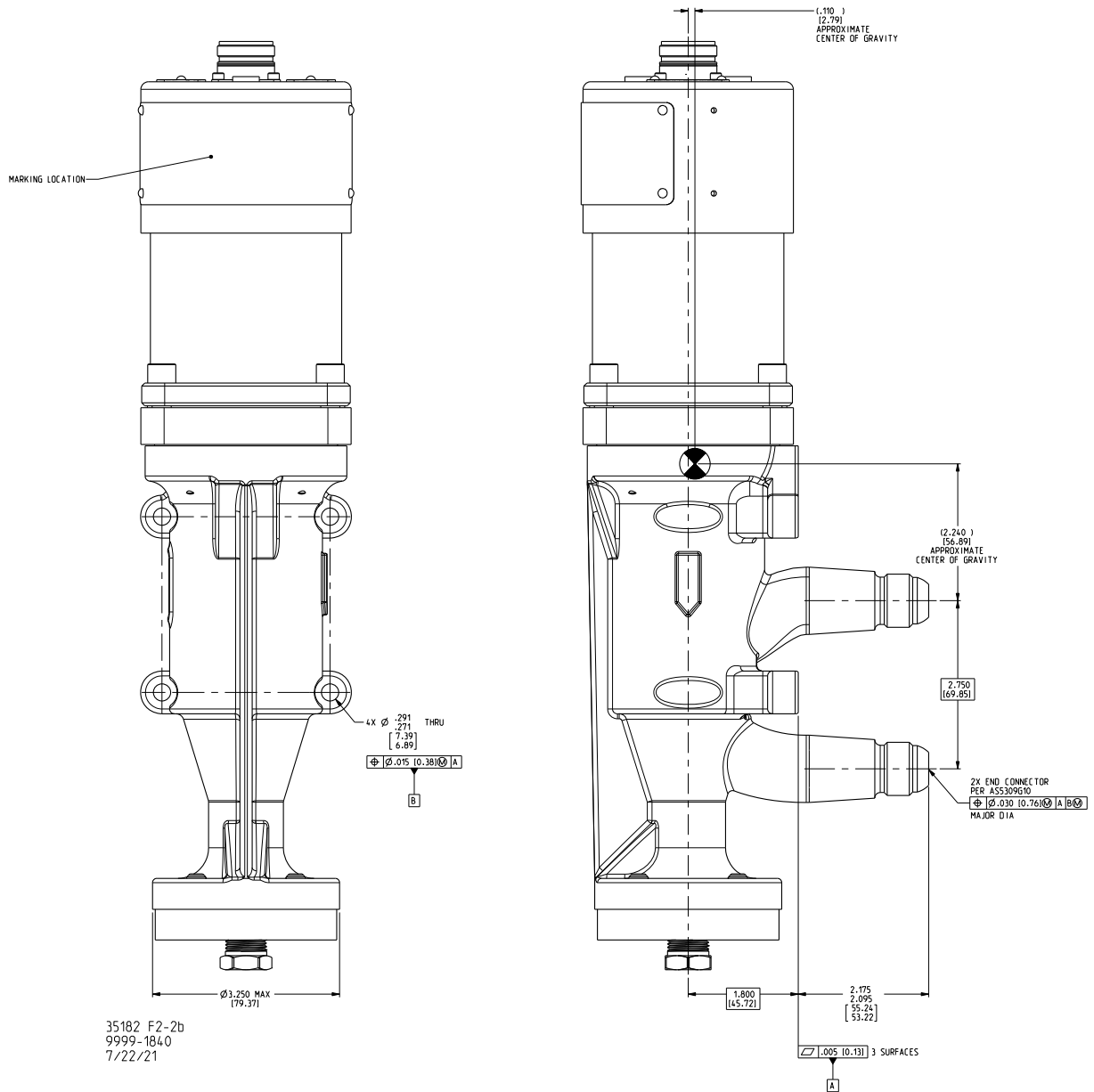

Figure 2-2b. Liquid Staging Valve Outline Drawing

Chapter 3. Installation

Receiving Instructions

The liquid staging valve is carefully packed at the factory to protect it from damage during shipping. However, careless handling during shipment can result in damage. If any damage to the liquid staging valve is discovered, immediately notify both the shipping agent and Woodward.

Unpacking Instructions

Carefully unpack the liquid staging valve and remove it from the shipping container. Do not remove the fluid or electric connection covers until the unit is mounted.

 WARNING	External fire protection is not provided in the scope of this product. It is the responsibility of the user to satisfy any applicable requirements for their system.
--	---

Installation Instructions

General

See the outline drawings (Figures 2-2a and 2-2b) and specifications for:

- Dimensions
- Fluid connections and fitting sizes
- Electrical connections
- Weight of the liquid staging valve

Note: The liquid staging valve may be mounted in any position with the long axis of the valve horizontal and the inlet and outlet ports oriented below this axis. If the liquid staging valve is to be installed near un-insulated/un-shielded steam valves or piping which exceed the maximum temperature described in this manual, radiation heat shields should be installed between the actuator and these hot surfaces.

The liquid staging valve is designed to be mounted directly to a mounting bracket. For the mating surface bolt patterns, threads, and torques, the recommendations in Table 3-1 must be followed. Graphite based anti-seize compound must be used on the bolt threads.

Table 3-1. Fastener Specifications

Thread Size	Bolt Length (in.)	Underhead Dia (in.)	Min Thread Engagement (in.)	Bolt Specification	Bolting Torque (Nm)	Bolting Torque (lbf-in)
1/4-28 UNF	1.125	0.438	0.375	AS 9557	7.34	65

Fluid Connections

The liquid staging valve has two fluid connections that must be made to fuel supply (inlet port) and fuel out (outlet port). Torque connection to 65 lb-ft (88 N-m).

Make provisions for proper filtration of the process fluid that will supply the liquid staging valve. The system filtration should be designed to minimize contamination within the process fluid. Excessive contamination in the process fluid may result in reduced performance or even damage.

The mounting bracket and tubing connected to the liquid staging valve must be constructed to minimize any transfer of vibration or other forces to the valve.



Do not disconnect process fluid connections when fuel pressure is applied. All required process connections must be made before fuel pressure is applied.

Electrical Connections

An overall wiring diagram is shown in Figure 3-2. Detailed wiring requirements for these connections will follow in the remainder of the electrical connections section.



EXPLOSION HAZARD
Do not remove covers or connect/disconnect electrical connectors unless power has been switched off or the area is known to be non-hazardous.

Input Power

The liquid staging valve requires a power source capable of supplying the necessary output voltage and current at full transient conditions. The maximum power in Watts (W) of a DC source can be calculated by multiplying the rated output voltage by the maximum current capability. The calculated power rating of the supply should be greater than or equal to the liquid staging valve requirements. The electrical power supply should be able to provide 1.1 A at 125 VDC continuously for each liquid staging valve installed on the turbine.

Cable selection and sizing are important to avoid power loss during operation. The power supply input at the actuator must always provide the required nominal voltage to operate the valve.

The input power wires must comply with local code requirements and be of sufficient size such that the power supply voltage minus the IR loss in the two lead wires to the liquid staging valve does not drop below the input minimum voltage requirement.

The liquid staging valve is not equipped with an input power disconnect. A means of disconnecting input power to the liquid staging valve must be provided for safe installation and servicing.

The liquid staging valve is not equipped with input power protection. A means of protecting input power to the liquid staging valve must be provided. Circuit breakers or fuses may be used to protect installation wiring and power sources from faults in the liquid staging valve or wiring.

Wiring

The liquid staging valve has one 7 pin connector (EN2997, shell size 14, 7 pin) that includes solenoid power and ground, switch NO, NC and Common. Pin 7 is unused. Refer to the wiring schematic below for pinout information.

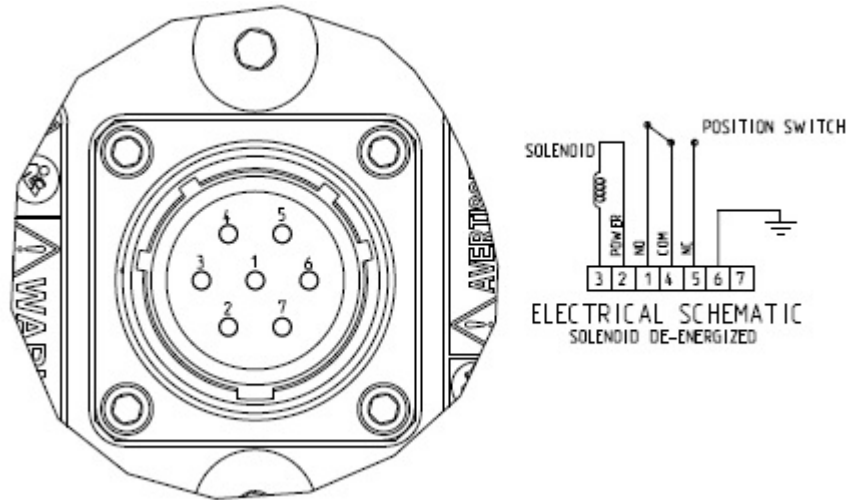

Figure 3-1. Solenoid Electrical Schematic

Note: NO refers to the position feedback switch neutral state. This circuit will be closed when the solenoid is de-energized and open when the solenoid is energized.

NC refers to the position feedback switch neutral state. This circuit will be open when the solenoid is de-energized and closed when the solenoid is energized.

The cable and connector must meet the same hazardous locations criteria as the liquid staging valve. Follow all installation recommendations and special conditions for safe use that are supplied with the connector. The cable insulation must have a temperature rating of at least 150 °C and 10 °C above the maximum ambient and fluid temperature.



WARNING

IP54 rating depends on proper installation of the mating electrical connector.

When installing the mating cable harness onto the liquid staging valve, make sure to thread the female connector is all the way onto the male connector. The colored ring on the male connector must be entirely covered by the colored ring on the female connector (refer to images below).

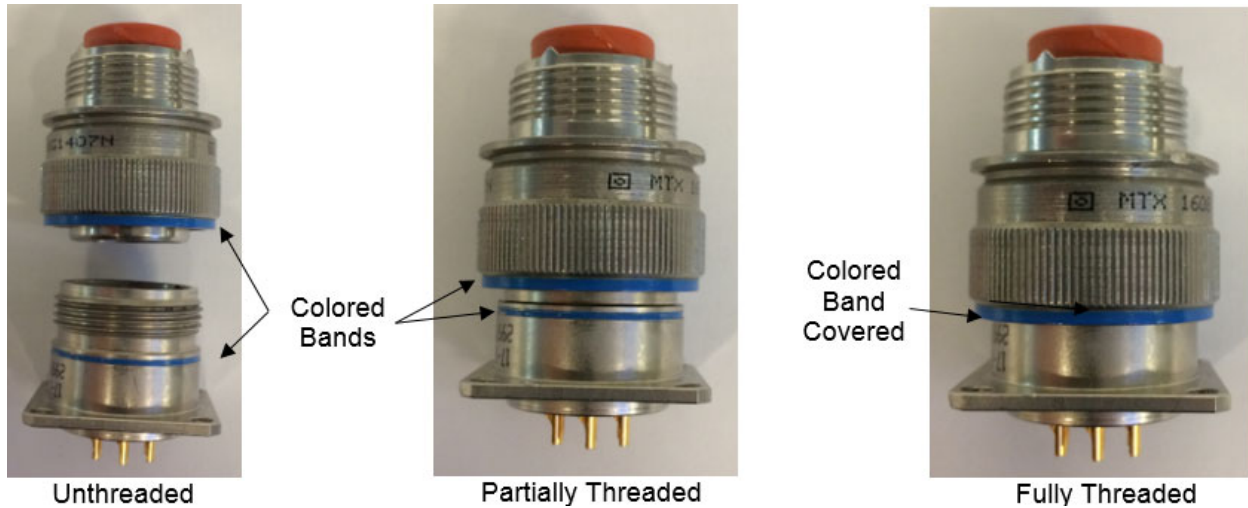

Figure 3-2. Mating Cable Harness to Liquid Staging Valve

NOTICE

Do not connect any cable grounds to “instrument ground”, “control ground”, or any non-earth ground system. Make all required electrical connections based on the wiring diagrams.

⚠ WARNING

ELECTRIC SHOCK

To reduce the risk of electric shock, the valve must be mounted to the support frame and the bolts torqued per Table 3-1.

Chapter 4. Operation

Operating the Liquid Staging Valve

Each liquid staging valve has a solenoid actuator that requires a DC voltage and current to close the valve. When the actuator is unpowered, an internal return spring returns the valve to its open (failsafe) position. Additionally, an internal position switch is used to annunciate valve position. The position switch is a SPDT type with a Normally Open (NO) and Normally Closed (NC) circuit. Either circuit can be used to detect when the valve is in its unpowered or open state.



HEARING PROTECTION

Due to typical noise levels in turbine (or engine) and environments, hearing protection should be worn when working on or around the Liquid Staging Valve.



HOT SURFACES

The surface of this product can become hot enough or cold enough to be a hazard. Use protective gear for product handling in these circumstances. Temperature ratings are included in the specification section of this manual.



EXPLOSION HAZARD

Do not remove covers or connect/disconnect electrical connectors unless power has been switched off or the area is known to be non-hazardous.

Energizing and De-Energizing the Actuator

The liquid staging valve solenoid can be energized to close by applying a voltage and current to the solenoid power terminals. When the voltage and current are removed, a return spring pushes the valve back to an open state.

Note: As the solenoid is de-energized, the collapsing magnetic field will generate a voltage spike (flyback) across the power terminals. It is important that protective voltage suppressing devices be used to prevent damage to the control system or power supply that operates the solenoid.

Valve Position Feedback

The built-in position switch can be used to detect the valve open state. The valve contacts the position switch when open, causing the switch to change states. When the valve moves to the closed position, the switch changes to its neutral state. Since the switch is a SPDT configuration, it has a Common, Normally Open (NO) and Normally Closed (NC) circuit. A small voltage can be applied to the common terminal of the switch. When the switch is in its neutral (non-actuated) state, the voltage will pass to the NC terminal of the switch, but not the NO terminal. This state corresponds with the valve closed state. When the switch is actuated, the poles change states so that the voltage then passes to the NO terminal but not the NC terminal. This state corresponds with the valve open state. The switch voltage can be sensed by the discrete input in the control system which can be configured to logically monitor and annunciate the valve state.

Chapter 5. Repair and Troubleshooting

General

Woodward Products covered under Woodward Product and Service Warranty (5-01-1205) are warranted to be free from defects in materials and workmanship, when installed and used in the manner for which they are intended, for a period of 18 months from the date of shipment from Woodward.

Repairs and servicing of the Liquid Staging Valve must be performed by Woodward or its authorized service facilities

Use of a connector that does not meet the hazardous area certification requirements or thread form or thread size will invalidate the suitability for hazardous locations.

 **WARNING****HEARING PROTECTION**

Due to typical noise levels in turbine (or engine) and environments, hearing protection should be worn when working on or around the Liquid Staging Valve.

 **WARNING****HOT SURFACES**

The surface of this product can become hot enough or cold enough to be a hazard. Use protective gear for product handling in these circumstances. Temperature ratings are included in the specification section of this manual.

 **WARNING****EXPLOSION HAZARD**

Do not remove covers or connect/disconnect electrical connectors unless power has been switched off or the area is known to be non-hazardous.

Never remove or alter the nameplate as it bears important information which may be necessary to service or repair the unit.

Return for Repair Instruction

See section titled "Returning Equipment for Repair" in Chapter 6 with same title.

Protective Packing

See section "Packing a Control" in Chapter 6.

Hardware Replacement

The Liquid Staging Valve contains no user-serviceable parts. It is recommended to send the valve to an authorized Woodward service facility for repair or servicing.

Troubleshooting and Troubleshooting Guide

General

The following troubleshooting guide will help you isolate trouble with the Liquid Staging Valve. Troubleshooting beyond this level is recommended ONLY when complete facility control testing is available.

Troubleshooting Procedure

This table is a general guide for isolating system problems. In general, most problems are a result of incorrect wiring or installation practices. Make sure that the system wiring, input/output connections, controls and contacts are correct and in good working order. Complete the checks in order. Each check assumes that the preceding checks have been completed and any problems have been corrected.

Table 5-1. Liquid Staging Valve Troubleshooting Guide

Problem	Cause	Remedy
Valve Fails to Open	Input power not completely removed from actuator	Check power source and make sure power is being completely removed from the actuator
	Valve seized/excessive fuel contamination	Ensure fuel cleanliness meets recommended filtration and ISO cleanliness levels specified in customer fuel specification.
	Operating temperature too high	Check ambient and fuel operating temperatures and verify that it falls within the requirements outlined in the Chapter 2: Environmental Specifications
	Component failure	The valve return spring or other component may have failed, causing the valve to stick in the open position
	Wiring harness not connected to connector, no position annunciation	Check electrical connections to ensure connections are correct
Valve Fails to Close	Input power below specified limit	Check power source and connections (refer to Chapter 2: Electrical Specifications)
	Valve seized/excessive fuel contamination	Ensure fuel cleanliness meets recommended filtration and ISO cleanliness levels specified in customer fuel specification.
	Operating temperature too high	Check ambient and fuel operating temperatures and verify that it falls within the requirements outlined in the Chapter 2: Environmental Specifications
	Component failure	The valve solenoid or other component may have failed, causing the valve to stick in the open position
	Wiring harness not connected to connector, no position annunciation	Check electrical connections to ensure connections are correct
Actuation Time Too High (>150ms)	Fuel pressure too high	Check fuel supply pressure and verify it is within the valve specifications (refer to Chapter 2: Fluid Specifications)
	Valve seized/excessive fuel contamination	Ensure fuel cleanliness meets recommended filtration and ISO cleanliness levels specified in customer fuel specification.

Problem	Cause	Remedy
	Operating temperature too high or too low	Check ambient and fuel operating temperatures and verify that it falls within the requirements outlined in the Chapter 2: Environmental Specifications
	Valve seized/excessive fuel contamination	Ensure fuel cleanliness meets recommended filtration and ISO cleanliness levels specified in customer fuel specification.
Position indicator not changing states	Wiring harness not connected to connector, no position annunciation	Check electrical connections to ensure connections are correct
	Component Failure	The valve position switch or other component may have failed, causing the switch to not operate or the valve to stick in the open position
Fuel flow too low/high	Flow calibration not correct	Check flow calibration to make sure it is correct for the application
	Obstruction in inlet or outlet	Check inlet and outlet ports, valve, and pipe passages for obstructions.
External fuel leakage	Seal failure	Leakage from valve seal may require valve overhaul.
	Bellows failure	Leakage from valve bellows may require valve overhaul.

Chapter 6.

Product Support and Service Options

Product Support Options

If you are experiencing problems with the installation, or unsatisfactory performance of a Woodward product, the following options are available:

- Consult the troubleshooting guide in the manual.
- Contact the manufacturer or packager of your system.
- Contact the Woodward Full Service Distributor serving your area.
- Contact Woodward technical assistance (see “How to Contact Woodward” later in this chapter) and discuss your problem. In many cases, your problem can be resolved over the phone. If not, you can select which course of action to pursue based on the available services listed in this chapter.

OEM or Packager Support: Many Woodward controls and control devices are installed into the equipment system and programmed by an Original Equipment Manufacturer (OEM) or Equipment Packager at their factory. In some cases, the programming is password-protected by the OEM or packager, and they are the best source for product service and support. Warranty service for Woodward products shipped with an equipment system should also be handled through the OEM or Packager. Please review your equipment system documentation for details.

Woodward Business Partner Support: Woodward works with and supports a global network of independent business partners whose mission is to serve the users of Woodward controls, as described here:

- A **Full Service Distributor** has the primary responsibility for sales, service, system integration solutions, technical desk support, and aftermarket marketing of standard Woodward products within a specific geographic area and market segment.
- An **Authorized Independent Service Facility (AISF)** provides authorized service that includes repairs, repair parts, and warranty service on Woodward's behalf. Service (not new unit sales) is an AISF's primary mission.

A current list of Woodward Business Partners is available at www.woodward.com/directory.

Product Service Options

The following factory options for servicing Woodward products are available through your local Full-Service Distributor or the OEM or Packager of the equipment system, based on the standard Woodward Product and Service Warranty (5-01-1205) that is in effect at the time the product is originally shipped from Woodward or a service is performed:

- Replacement/Exchange (24-hour service)
- Flat Rate Repair
- Flat Rate Remanufacture

Replacement/Exchange: Replacement/Exchange is a premium program designed for the user who is in need of immediate service. It allows you to request and receive a like-new replacement unit in minimum time (usually within 24 hours of the request), providing a suitable unit is available at the time of the request, thereby minimizing costly downtime. This is a flat-rate program and includes the full standard Woodward product warranty (Woodward Product and Service Warranty 5-01-1205).

This option allows you to call your Full-Service Distributor in the event of an unexpected outage, or in advance of a scheduled outage, to request a replacement control unit. If the unit is available at the time of the call, it can usually be shipped out within 24 hours. You replace your field control unit with the like-new replacement and return the field unit to the Full-Service Distributor.

Charges for the Replacement/Exchange service are based on a flat rate plus shipping expenses. You are invoiced the flat rate replacement/exchange charge plus a core charge at the time the replacement unit is shipped. If the core (field unit) is returned within 60 days, a credit for the core charge will be issued.

Flat Rate Repair: Flat Rate Repair is available for the majority of standard products in the field. This program offers you repair service for your products with the advantage of knowing in advance what the cost will be. All repair work carries the standard Woodward service warranty (Woodward Product and Service Warranty 5-01-1205) on replaced parts and labor.

Flat Rate Remanufacture: Flat Rate Remanufacture is very similar to the Flat Rate Repair option with the exception that the unit will be returned to you in "like-new" condition and carry with it the full standard Woodward product warranty (Woodward Product and Service Warranty 5-01-1205). This option is applicable to mechanical products only.

Returning Equipment for Repair

If a control (or any part of an electronic control) is to be returned for repair, please contact your Full-Service Distributor in advance to obtain Return Authorization and shipping instructions.

When shipping the item(s), attach a tag with the following information:

- Return authorization number
- Name and location where the control is installed
- Name and phone number of contact person
- Complete Woodward part number(s) and serial number(s)
- Description of the problem
- Instructions describing the desired type of repair

Packing a Control

Use the following materials when returning a complete control:

- Protective caps on any connectors
- Antistatic protective bags on all electronic modules
- Packing materials that will not damage the surface of the unit
- At least 100 mm (4 inches) of tightly packed, industry-approved packing material
- A packing carton with double walls
- A strong tape around the outside of the carton for increased strength

NOTICE

To prevent damage to electronic components caused by improper handling, read and observe the precautions in Woodward manual 82715, *Guide for Handling and Protection of Electronic Controls, Printed Circuit Boards, and Modules*.

Replacement Parts

When ordering replacement parts for controls, include the following information:

- The part number(s) (XXXX-XXXX) that is on the enclosure nameplate
- The unit serial number, which is also on the nameplate

Engineering Services

Woodward offers various Engineering Services for our products. For these services, you can contact us by telephone, by email, or through the Woodward website.

- Technical Support
- Product Training
- Field Service

Technical Support is available from your equipment system supplier, your local Full-Service Distributor, or from many of Woodward's worldwide locations, depending upon the product and application. This service can assist you with technical questions or problem solving during the normal business hours of the Woodward location you contact. Emergency assistance is also available during non-business hours by phoning Woodward and stating the urgency of your problem.

Product Training is available as standard classes at many of our worldwide locations. We also offer customized classes, which can be tailored to your needs and can be held at one of our locations or at your site. This training, conducted by experienced personnel, will assure that you will be able to maintain system reliability and availability.

Field Service engineering on-site support is available, depending on the product and location, from many of our worldwide locations or from one of our Full-Service Distributors. The field engineers are experienced both on Woodward products as well as on much of the non-Woodward equipment with which our products interface.

For information on these services, please contact us via telephone, email us, or use our website: www.woodward.com.

Contacting Woodward's Support Organization

For the name of your nearest Woodward Full-Service Distributor or service facility, please consult our worldwide directory at www.woodward.com, which also contains the most current product support and contact information.

You can also contact the Woodward Customer Service Department at one of the following Woodward facilities to obtain the address and phone number of the nearest facility at which you can obtain information and service.

Products Used in Electrical Power Systems	
Facility	Phone Number
Brazil	+55 (19) 3708 4800
China	+86 (512) 8818 5515
Germany	+49 (711) 78954-510
India	+91 (124) 4399500
Japan	+81 (43) 213-2191
Korea	+82 (32) 422-5551
Poland	+48 (12) 295 13 00
United States	+1 (970) 482-5811

Products Used in Engine Systems	
Facility	Phone Number
Brazil	+55 (19) 3708 4800
China	+86 (512) 8818 5515
Germany	+49 (711) 78954-510
India	+91 (124) 4399500
Japan	+81 (43) 213-2191
Korea	+ 82 (32) 422-5551
The Netherlands	+31 (23) 5661111
United States	+1 (970) 482-5811

Products Used in Industrial Turbomachinery Systems	
Facility	Phone Number
Brazil	+55 (19) 3708 4800
China	+86 (512) 8818 5515
India	+91 (124) 4399500
Japan	+81 (43) 213-2191
Korea	+ 82 (32) 422-5551
The Netherlands	+31 (23) 5661111
Poland	+48 (12) 295 13 00
United States	+1 (970) 482-5811

Technical Assistance

If you need to contact technical assistance, you will need to provide the following information. Please write it down here before contacting the Engine OEM, the Packager, a Woodward Business Partner, or the Woodward factory:

General

Your Name _____

Site Location _____

Phone Number _____

Fax Number _____

Prime Mover Information

Manufacturer _____

Turbine Model Number _____

Type of Fuel (diesel, jet, turbine, etc) _____

Power Output Rating _____

Application (power generation, marine,
etc.) _____

Control/Governor Information

Control/Governor #1

Woodward Part Number & Rev. Letter _____

Control Description or Governor Type _____

Serial Number _____

Control/Governor #2

Woodward Part Number & Rev. Letter _____

Control Description or Governor Type _____

Serial Number _____

Control/Governor #3

Woodward Part Number & Rev. Letter _____

Control Description or Governor Type _____

Serial Number _____

Symptoms

Description _____

If you have an electronic or programmable control, please have the adjustment setting positions or the menu settings written down and with you at the time of the call.

Chapter 7.

Asset Management and Refurbishment Scheduling Period

The following recommendations regarding the Woodward designed and manufactured liquid staging valve assembly are to assist in properly managing the reliability and availability expectations established for turbines. While there are electronic control systems designed to monitor and diagnose the operational performance of these components, control monitoring cannot replace normal preventative maintenance practices. It is important to follow these recommendations in order to avoid unnecessary and unscheduled shutdowns.

This product is designed for continuous operation under normal industrial operating conditions. There are no components that require periodic service between scheduled major turnarounds (normally every five to eight years depending on the site and application). During major outages, Woodward recommends the liquid staging valve be send back to Woodward or a Woodward Authorized Independent Service Facility (AISF) for inspection, component servicing and to take advantage of any related hardware improvements.

Installations that do not meet “normal” industrial operating conditions may require customized maintenance cycles to maximize reliability, performance, and asset life. Contact your local Woodward Representative for a detailed evaluation of your site conditions to determine the right maintenance cycles for your installation.

Woodward’s overhaul services will return the unit to “like new” condition, ready for another full operating cycle, lasting until the next planned maintenance outage. Upon reaching the recommended maintenance cycle of the auxiliary equipment, please contact either the site turbine OEM service representative, local Woodward distributor or Woodward Authorized Independent Service Facility to initiate services. Refer to Chapter 6 for Product Support and Services options.

Chapter 8.

Long-Term Storage Requirements

Units that will not be put into service within twelve months should be packaged for long-term storage as described in Woodward manual 25075, *Commercial Preservation Packaging for Storage of Mechanical-Hydraulic Controls*. This product is designed for continuous storage in a location with adequate protection from water and dust with an ambient temperature of $-40\text{ }^{\circ}\text{C}$ to $+150\text{ }^{\circ}\text{C}$.

Appendix

Commissioning Checklist

When installing and commissioning the liquid staging valve unit, the following checklist can be used as a guide to ensure proper installation and successful commissioning.

Category	Parameter	Specification	This Installation
Power Supply	Actuator Supply Voltage (as measured at connector)	125 VDC (95 to 140 VDC)	
	Supply Current (as measured at connector)	1.1 Amps Max	
	Wiring: Actuator Power Positive	Connector Pin #2 or #3 (opposite from below)	
	Wiring: Actuator Power Negative	Connector Pin #3 or #2 (opposite from above)	
	Wiring: Actuator Ground		
	Isolation Breakers	Breakers used between PS + and – and actuator	
Position Switch Feedback	Feedback Supply Voltage	10-32 VDC	
	Feedback Supply Current	100 mA Max	
	Wiring: Switch Common	Connector Pin # 4	
	Wiring: Switch NO	Connector Pin #5	
	Wiring: Switch NC	Connector Pin #1	
	Isolation Breakers	Breakers used between Switch Common, NO, NC	
Housing Fuel Port Protectors	Remove plastic port protectors before Installation		
Mounting Bolts	Bolt Thread Size	1/4-28	
	Bolt Length	28.6 mm (1.125 in)	
	Bolt Type	12-point, Flange Style , AS 9557	
	Torque	7.34 Nm (65 in-lb.)	
Connector	Connector Secured	See Figure 3-1	
	Ground	Connector Pin # 6 connected to control ground	
Actuation Times	Open/Close Slew Time	< 150 ms	
Proof Test	Operation of Proof Test	Initiate proof test and ensure correct operation of valve and actuator	
Leakage	Seat Leakage Rate	Per ANSI FCI 70-2 Liquid: Class V (2.3 sccm air) Purge: Class IV (203 sccm air)	

Revision History

New Manual—

Declarations

EU DECLARATION OF CONFORMITY

EU DoC No.: 00549-EU-02-01
Manufacturer's Name: WOODWARD INC.
Manufacturer's Contact Address: 1041 Woodward Way
 Fort Collins, CO 80524 USA
Model Name(s)/Number(s): Gas Staging Valve and Liquid Staging Valve
The object of the declaration described above is in conformity with the following relevant Union harmonization legislation: Directive 2014/34/EU of the European Parliament and of the Council of 26 February 2014 on the harmonization of the laws of the Member States relating to equipment and protective systems intended for use in potentially explosive atmospheres
Markings in addition to CE marking:  II 3 G, Ex nA nC IIC T220°C Gc
Applicable Standards: EN60079-0: 2018 – Explosive Atmospheres – Part 0: Equipment – General requirements
 EN60079-15: 2010 – Explosive Atmospheres – Part 15: Equipment protection by type of protection “n”

This declaration of conformity is issued under the sole responsibility of the manufacturer
 We, the undersigned, hereby declare that the equipment specified above conforms to the above Directive(s).

MANUFACTURER

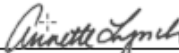

Signature
Annette Lynch

Full Name
Engineering Manager

Position
Woodward, Fort Collins, CO, USA

Place
11-May-2022

Date

DECLARATION OF INCORPORATION Of Partly Completed Machinery 2006/42/EC
--

File name: 00549-EU-02-02
Manufacturer's Name: WOODWARD INC.
Manufacturer's Address: 1041 Woodward Way
 Fort Collins, CO 80524 USA
Model Names: Gas Staging Valve and Liquid Staging Valve

This product complies, where applicable, with the following
Essential Requirements of Annex I: 1.1, 1.2, 1.3, 1.5, 1.6, 1.7

The relevant technical documentation is compiled in accordance with part B of Annex VII. Woodward shall transmit relevant information if required by a reasoned request by the national authorities. The method of transmittal shall be agreed upon by the applicable parties.

The person authorized to compile the technical documentation:

Name: Dominik Kania, Managing Director
Address: Woodward Poland Sp. z o.o., ul. Skarbowa 32, 32-005 Niepolomice, Poland

This product must not be put into service until the final machinery into which it is to be incorporated has been declared in conformity with the provisions of this Directive, where appropriate.

The undersigned hereby declares, on behalf of Woodward Inc. of Loveland and Fort Collins, Colorado that the above referenced product is in conformity with Directive 2006/42/EC as partly completed machinery:

MANUFACTURER

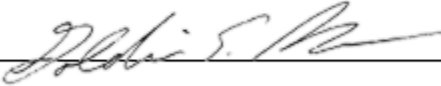
Signature	
Full Name	Goldino Alves
Position	Director of Engineering
Place	Woodward Inc., Fort Collins, CO, USA
Date	7/22/2021

THIS PAGE INTENTIONALLY LEFT BLANK

We appreciate your comments about the content of our publications.

Send comments to: icinfo@woodward.com

Please reference publication **35182**.



B 3 5 1 8 2 : -



PO Box 1519, Fort Collins CO 80522-1519, USA
1041 Woodward Way, Fort Collins CO 80524, USA
Phone +1 (970) 482-5811

Email and Website—www.woodward.com

Woodward has company-owned plants, subsidiaries, and branches, as well as authorized distributors and other authorized service and sales facilities throughout the world.

Complete address / phone / fax / email information for all locations is available on our website.