

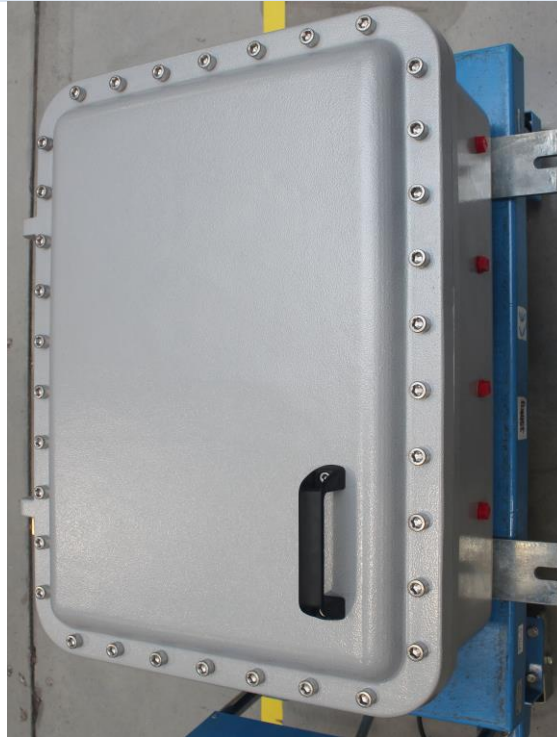

Product Manual 35220
(Revision A, 12/2023)
Original Instructions



***STExcite*[™] Industrial Gas Turbine Ignition System**

8408-9001
STExcite Four Channel Version
Explosion Proof Package

Installation and Operation Manual



**General
Precautions**

Read this entire manual and all other publications pertaining to the work to be performed before installing, operating, or servicing this equipment.

Practice all plant and safety instructions and precautions.

Failure to follow instructions can cause personal injury and/or property damage.



Revisions

This publication may have been revised or updated since this copy was produced. The latest version of most publications is available on the Woodward website.

<http://www.woodward.com>

If your publication is not there, please contact your customer service representative to receive the latest copy.



Proper Use

Any unauthorized modifications to or use of this equipment outside its specified mechanical, electrical, or other operating limits may cause personal injury and/or property damage, including damage to the equipment. Any such unauthorized modifications: (i) constitute "misuse" and/or "negligence" within the meaning of the product warranty thereby excluding warranty coverage for any resulting damage, and (ii) invalidate product certifications or listings.



**Translated
Publications**

If the cover of this publication states "Translation of the Original Instructions" please note:

The original source of this publication may have been updated since this translation was made. The latest version of most publications is available on the Woodward website.

www.woodward.com/publications

Always compare with the original for technical specifications and for proper and safe installation and operation procedures.

If your publication is not on the Woodward website, please contact your customer service representative to get the latest copy.

Revisions— A bold, black line alongside the text identifies changes in this publication since the last revision.

Woodward reserves the right to update any portion of this publication at any time. Information provided by Woodward is believed to be correct and reliable. However, no responsibility is assumed by Woodward unless otherwise expressly undertaken.

Contents

WARNINGS AND NOTICES	2
ELECTROSTATIC DISCHARGE AWARENESS.....	3
REGULATORY COMPLIANCE.....	4
CHAPTER 1. GENERAL INFORMATION	7
CHAPTER 2. INSTALLATION/CALIBRATION	11
Unpacking	11
Installation	11
Calibration	14
Specifications	14
Igniter Cables	15
Igniters.....	16
CHAPTER 3. OPERATION AND SYSTEM DESCRIPTION.....	17
How to Operate	17
Software Information	17
Detailed System Description	17
CHAPTER 4. TROUBLESHOOTING	19
CHAPTER 5. PRODUCT SUPPORT AND SERVICE OPTIONS	20
Product Support Options.....	20
Product Service Options	20
Returning Equipment for Repair	21
Replacement Parts.....	22
Engineering Services	22
Contacting Woodward's Support Organization	22
Technical Assistance	23
REVISION HISTORY	24
DECLARATIONS	25

Illustrations and Tables

Figure 1-1. Turbine Ignition System.....	7
Figure 1-2. Outline Drawing	8
Figure 1-3. Outline Details	9
Figure 1-4. Connectors Description	10
Figure 1-5. Four Channel STExcite Control Box (cover removed)	10
Figure 1-6. STExcite End of Cable Mounting Kit	15
Figure 1-7. 603P960 Igniter	16
Table 2-1. Specifications.....	14
Table 2-2. Ignition Cable Specifications.....	15

Warnings and Notices

Important Definitions



This is the safety alert symbol used to alert you to potential personal injury hazards. Obey all safety messages that follow this symbol to avoid possible injury or death.

- **DANGER** - Indicates a hazardous situation, which if not avoided, will result in death or serious injury.
- **WARNING** - Indicates a hazardous situation, which if not avoided, could result in death or serious injury.
- **CAUTION** - Indicates a hazardous situation, which if not avoided, could result in minor or moderate injury.
- **NOTICE** - Indicates a hazard that could result in property damage only (including damage to the control).
- **IMPORTANT** - Designates an operating tip or maintenance suggestion.

WARNING

**Overspeed /
Overtemperature /
Overpressure**

The engine, turbine, or other type of prime mover should be equipped with an overspeed shutdown device to protect against runaway or damage to the prime mover with possible personal injury, loss of life, or property damage.

The overspeed shutdown device must be totally independent of the prime mover control system. An overtemperature or overpressure shutdown device may also be needed for safety, as appropriate.

WARNING

**Personal Protective
Equipment**

The products described in this publication may present risks that could lead to personal injury, loss of life, or property damage. Always wear the appropriate personal protective equipment (PPE) for the job at hand. Equipment that should be considered includes but is not limited to:

- Eye Protection
- Hearing Protection
- Hard Hat
- Gloves
- Safety Boots
- Respirator

Always read the proper Material Safety Data Sheet (MSDS) for any working fluid(s) and comply with recommended safety equipment.

WARNING

Start-up

Be prepared to make an emergency shutdown when starting the engine, turbine, or other type of prime mover, to protect against runaway or overspeed with possible personal injury, loss of life, or property damage.

NOTICE

All elements of STExcite™ Industrial Gas Turbine Ignition System:

- Ignition box
- Igniter cables
- Igniters

do not contain radioactive elements or materials used.

Electrostatic Discharge Awareness

NOTICE

Electrostatic Precautions

Electronic controls contain static-sensitive parts. Observe the following precautions to prevent damage to these parts:

- Discharge body static before handling the control (with power to the control turned off, contact a grounded surface, and maintain contact while handling the control).
- Avoid all plastic, vinyl, and Styrofoam (except antistatic versions) around printed circuit boards.
- Do not touch the components or conductors on a printed circuit board with your hands or with conductive devices.

To prevent damage to electronic components caused by improper handling, read and observe the precautions in Woodward manual **82715**, *Guide for Handling and Protection of Electronic Controls, Printed Circuit Boards, and Modules*.

Follow these precautions when working with or near the control.

1. Avoid the build-up of static electricity on your body by not wearing clothing made of synthetic materials. Wear cotton or cotton-blend materials as much as possible since these do not store static electric charges as much as synthetics.
2. Woodward does not allow for PCBAs to be removed or replaced from the device but does allow for modules to be replaced in metal brackets. In such cases, PCBAs can be accessible. Follow ESD precautions during module replacement.
 - Install replacement modules with ESD protection equipment, such as antistatic wristband.
 - Do not touch any part of the PCB except the edges.
 - Do not touch the electrical conductors, connectors, or components with conductive devices or with your hands.

Regulatory Compliance

European Compliance for CE Mark

These listings are limited only to those units bearing the CE Marking.

EMC Directive: Declared to Directive 2014/30/EU of the European Parliament and of the Council of 26 February 2014 on the harmonization of the laws of the Member States relating to electromagnetic compatibility (EMC).

ATEX – Potentially Explosive Atmospheres Directive: Directive 2014/34/EU on the harmonization of the laws of the Member States relating to equipment and protective systems intended for use in potentially explosive atmospheres.

STExcite Enclosure
II 2 G Ex db IIB+H2 T4 Gb
ETL23ATEX0302X

Ignition Cables
II 2 G Ex db IIB+H2 T2 Gb
ETL23ATEX0302X

Ignitors
II 2 G Ex db IIB+H2 490C Gb
ETL23ATEX0301X

NOTE: Ignitors are listed by serial number on the certificate.

Other European Compliance:

Compliance with the following European Directives or standards does not qualify this product for application of the CE Marking:

RoHS Directive: Restriction of Hazardous Substances 2011/65/EU:
Woodward turbomachinery systems products are intended exclusively for sale and use only as a part of Large Scale Fixed Installations per the meaning of Art.2.4(e) of directive 2011/65/EU. This fulfills the requirements stated in Art.2.4(c), and as such, the product is excluded from the scope of RoHS2.

Other International Compliance

These listings are limited only to those units bearing the IECEx certificate number:

IECEx: Certified for use in explosive atmospheres per certificate:

STExcite Enclosure
II 2 G Ex db IIB+H2 T4 Gb
IECEx ETL 23.0027X

Ignition Cables
II 2 G Ex db IIB+H2 T2 Gb
IECEx ETL 23.0027X

Ignitors
II 2 G Ex db IIB+H2 490C Gb
IECEx ETL 23.0026X

NOTE: Ignitors are listed by serial number on the certificate

Special Conditions for Safe Use:

Wiring must be in accordance with International Zone 1 Category 2 wiring methods as applicable, and in accordance with the authority having jurisdiction.

Field wiring must be suitable for at least 90°C for operating ambient temperatures expected to exceed 70°C.

Connect ground terminal to earth ground before installing the input power.

Do not connect more than one main power supply to any one fuse or circuit breaker.

Equipment described in this instruction manual (enclosures, cables, ignitors) are intended to only be used as a complete certified system; no substitutions allowed.

⚠ WARNING	SHOCK HAZARD – Do not remove the cover of the STExcite™ while AC power is applied. Hazardous voltages exist within the unit when AC power is applied. Wait two minutes after AC power is removed to allow the hazardous voltages to bleed off before opening the cover. Remember to remove power from both power input ports.
------------------	--

Specific Conditions of Use for IECEx and ATEX:**STExcite System (Exciter and Cables)**

- The ignition system shall only be used with certified Woodward Inc. 603P960 Igniter.
- The maximum process temperature at the mounting threads of the igniter to the turbine combustor shall be no more than 480°C.
- No modification or repair shall be made on the flame paths.
- A tightening torque of 14 Nm shall be used on the proprietary igniter connector nut.

Igniter

- The maximum process temperature at the mounting threads shall be no more than 480°C.
- No modification or repair shall be made on the flame paths.
- The ignitor shall be used with a connector assembly certificated in IECEx ETL 23.0027X and ETL23ATEX0302X.
- Product ambient range is $-20^{\circ}\text{C} \leq T_{\text{amb}} \leq +70^{\circ}\text{C}$.
- The product ignitor has been evaluated with respect to a maximum pressure of 2800 kPa. It shall be ensured that pressure within the ignition chamber does not exceed this.
- Earthing of the equipment is intended to be completed through installation to the turbine housing and through connection to the connector assembly. The end user shall verify earth connection is made to the equipment body.

Relevant Special Conditions from the Ex db Certified Enclosure:

The flameproof joints have different values from those specified in the tables of the EN 60079-1 standard. For any repairs, contact the manufacturer.

The screws used to assemble the various parts of explosion-proof enclosures must be of quality higher or equal to 450 MPa, or 600 MPa for version XL at ambient temperatures lower than -20°C.



EXPLOSION HAZARD – Do not apply power to the STExcite™ without first connecting both igniter cable assemblies to both the STExcite and to the igniters.



In locations where high external humidity and internal temperature variations (e.g., frequent on-off cycles) may cause condensation inside the equipment, the interior should be periodically inspected.



EXPLOSION HAZARD—Do not connect or disconnect while circuit is live unless area is known to be non-hazardous.

Chapter 1.

General Information

The Four Channel STExcite™ System consists of two dual channel drivers with two high-energy ignition outputs that interfaces with flexible ignition leads and igniters. In total, four channels are available in the system.

Figure 1-1 illustrates a typical turbine ignition system. The four channel exciter box is the interface between an intelligent turbine combustion controller and four turbine igniters in the combustion chamber. The exciter converts electrical energy in the form of 230 VAC into a high-current ignition pulse. The exciter box is connected to the turbine igniters through flexible high voltage leads.

Inside the explosion proof box there are two dual channel STExcite modules. Each module has a separate power input port. Each dual channel exciter module is a “normally on” device that outputs ignition pulses whenever input power is applied through an external exciter relay. The “ON” or “OFF” state of the exciter relays are controlled by the turbine combustion controller. Both power input ports may be powered from the same power source if it is needed by application.

When input power is applied, the exciter’s diagnostic outputs are energized after passing self-diagnostics. If the exciter electronics sense a catastrophic fault condition in either or both output channels, the exciter’s diagnostic outputs de-energizes.

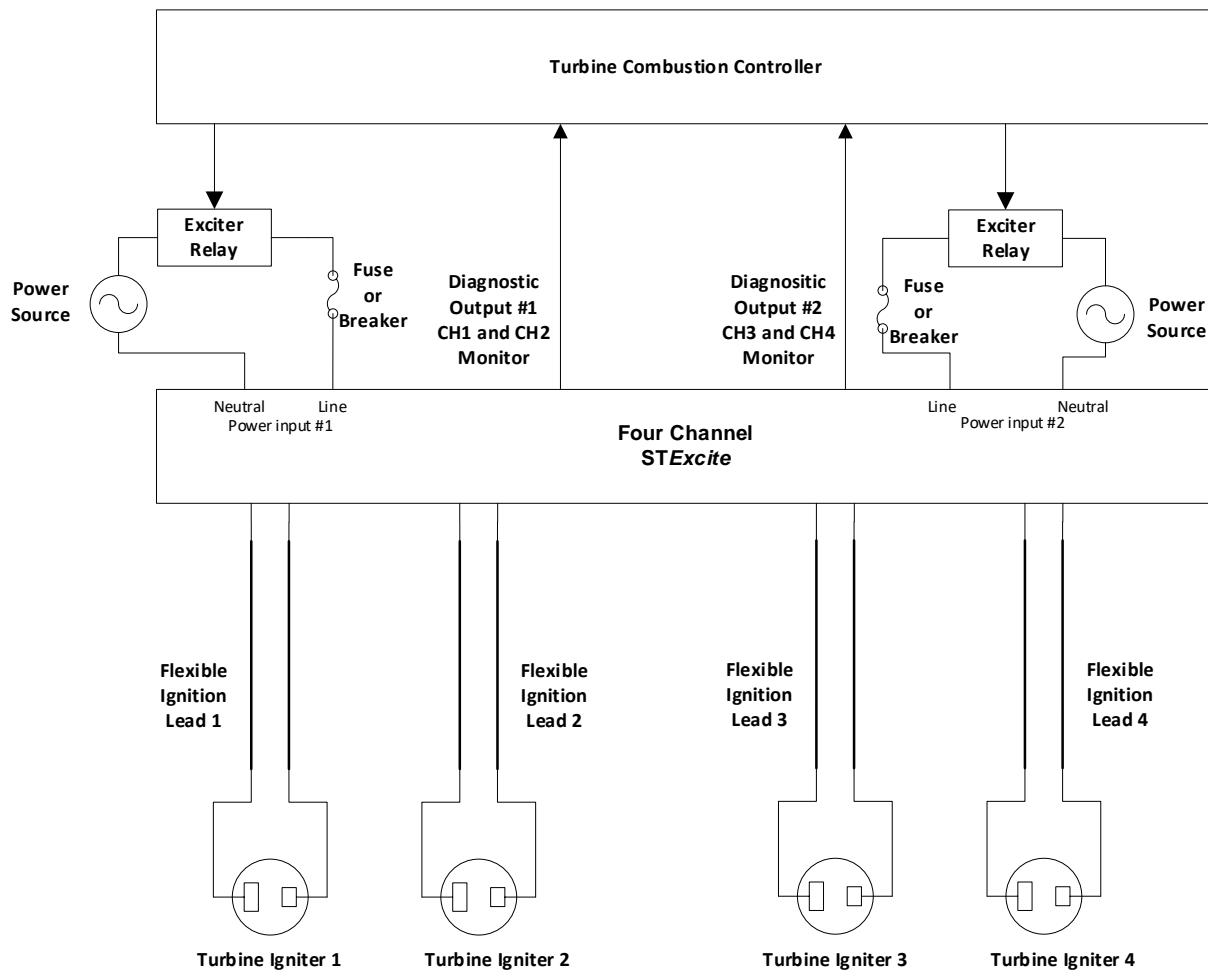

Figure 1-1. Turbine Ignition System

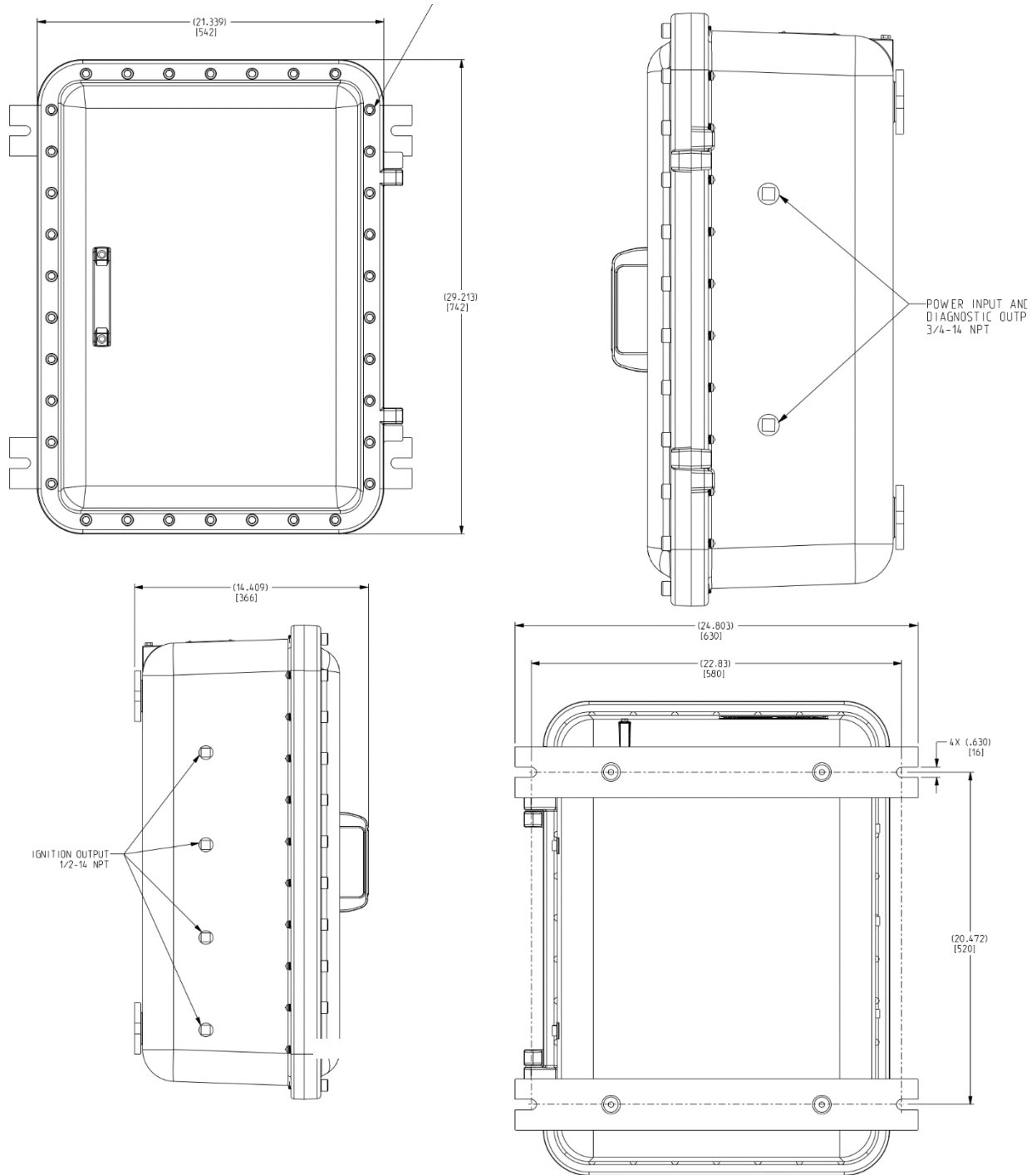

Figure 1-2. Outline Drawing

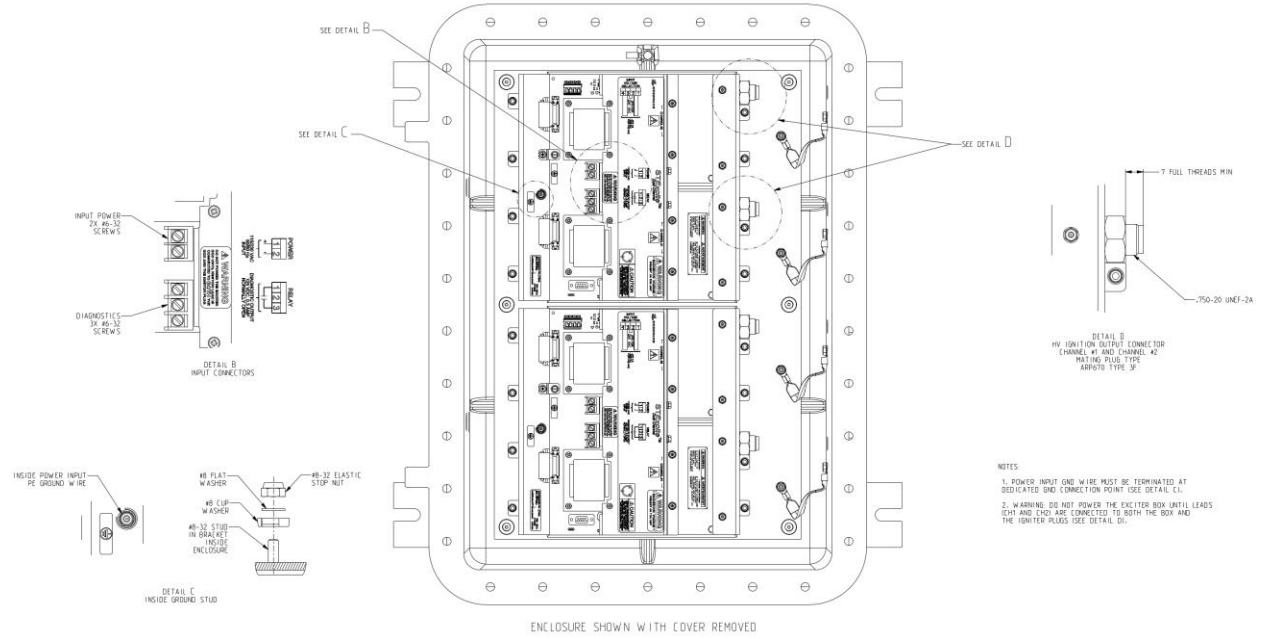

Figure 1-3. Outline Details

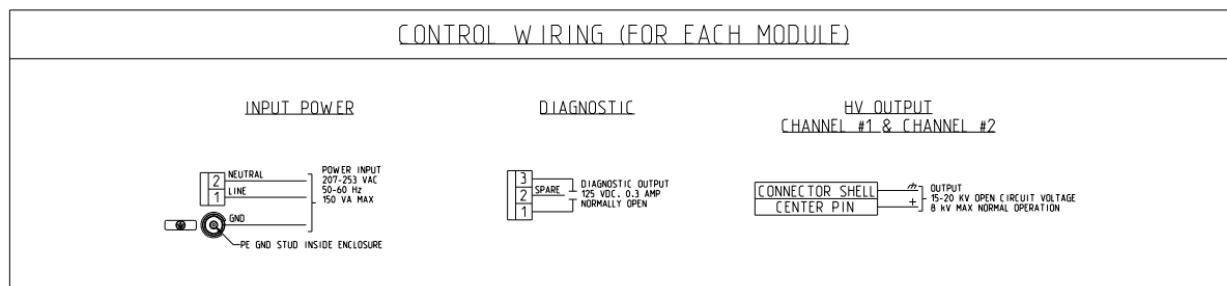

Figure 1-4. Connectors Description



Figure 1-5. Four Channel STExcite Control Box (cover removed)

Chapter 2. Installation/Calibration

Unpacking

Check the shipping container for evidence of mishandling during shipping. Carefully remove the driver from the shipping container. Check the hardware for evidence of damage during shipping. Notify the shipper and Woodward if shipping damage is found.

Installation

WARNING

Due to the hazardous location listings associated with this product, proper wire type and wiring practices are critical to operation.

Proper Wiring

CAUTION

The power supply mains should be properly fused according to the National Electrical Code. The recommended fuse is a European Type T fuse.

Power Supply Mains Fuse

CAUTION

A switch or circuit breaker shall be included in the building installation that is close to the equipment and within easy reach of the operator and that is clearly marked as the disconnecting device for the equipment.

Disconnecting Device

NOTICE

Plant Wiring Diagram Notes:

The base plate ground stud is to be connected to the system electrical ground.

All wiring shall be rated at 300V minimum and for the temperature that the wiring will be subjected to in the final installation.

1. Mount the four channel STExcite™ control box on the turbine according to the turbine manufacturer's production drawings.
2. The four channel STExcite control box may work with dedicated HV ignition leads that can be mounted to four HV NPT thread ports and to ARP 670 output connectors inside the box.
3. Go through the explosion proof box wall NPT thread and then install ARP670 connection kit to the lead. Install the kit only when the inner wire is already inside the explosion proof box.
4. Attach the ignition lead ends to the high energy ignition output ARP 670 (see Figure 1-3 for details). Use a tool to fully seat the nut on the lead to the output connector, so it cannot be loosened by hand.
5. Connect the other end of the ignition lead to an igniter installed in the combustion chamber. Route and secure the entire length of the lead to prevent damage and flexing during operation.

NOTICE

The STExcite™ used in box are preconfigured to operate with 230 VAC utility grid. Do not change the configuration jumpers for 115 VAC, as the four channel system is dedicated to 230 VAC setting only.

Damage to the STExcite control will occur if 230 VAC is applied to a unit configured for 115 VAC.

WARNING

EXPLOSION HAZARD - Do not apply power to the unit without first connecting all igniter cable assemblies to both the dual channel STExcite™ modules and to all four igniters. Igniters shall be mounted to the engine before applying power.

6. Make sure that a safety ground connection is made through the power connector or through the terminal provided on the enclosure (Figure 1-3). Bonding connections are provided on the enclosure, and it is intended that the installer do the bonding in accordance with local regulations.

WARNING

SHOCK HAZARD – Do not remove the cover of the STExcite™ while AC power is applied. Hazardous voltages exist within the unit when AC power is applied. Wait 2 minutes after AC power is removed to allow hazardous voltages to bleed off before opening the cover. Be sure to disconnect both power input ports.

7. Mount the power wires from the turbine combustion controller to the power input holes provided in the box. Use appropriate glands that can be used in explosion atmospheres and that provide IP66 ingress protection level. If only one port is used to provide input power, the second one shall be closed using a dedicated blind plug that is provided by Woodward.
8. Connect the input power leads from the turbine combustion controller to the power input terminals (Figures 1-3 and 1-4) using 1.5 mm²– 2.1 mm² (16 AWG – 14 AWG) wire with ring terminals suitable for #6 screws. Torque terminal screws to 1 – 1.35 Nm (9-12 lb-in).
9. If diagnostic relay output is planned to be used, connect the diagnostic output leads for the turbine combustion controller to the relay output terminals (Figures 1-3 and 1-4) using 1 mm² (18 AWG) wire with ring terminals suitable for #6 screws. Torque terminal screws to 1 – 1.35 Nm (9-12 lb-in).
10. Connect earth ground to the PE Ground lug as shown in Figure 1-3. Use a 30 cm long by 13 mm wide (12 inch long, 1/2 inch wide) or shorter flat hollow braid or comparable surface area wire. Use gauge as large as power wires or larger.
11. When all wires and HV leads are connected to the module ports inside the box then the top cover of the explosion proof box may be closed and screwed. To ensure an IP66 degree of protection rating, silicone grease is needed. A tube of silicon is provided by Woodward. This silicon grease needs to be restored each time the top cover is opened. Other examples of sealing compounds are Loctite 8104, Loxeal GS9.



EXPLOSION HAZARD – Use extreme care with the cover, fasteners, and joints of the STExcite enclosure to preserve its suitability for hazardous locations. Failure to follow these instructions could lead to compromised flamepaths, resulting in an uncontained explosion.

Before installing the cover, the joints on both surfaces must be clean of debris and visually inspected for damage. If in doubt, surface roughness exceeding 6.3 μ m is unacceptable.

Use only the M12 cover fasteners provided with the certified enclosure, and torque to 74 N-m.

12. Step by step assembly instruction with photos was prepared by Woodward.

Calibration

This unit requires no setup or calibration.

Specifications

Table 2-1. Specifications

Rated Input Power	230 VAC 50/60 Hz 150 VA max. per one input port (300VA max per both modules)
Input Power Range	207 – 253 VAC
Spark Rate	(1.8 ± 0.1) sparks/second
Spark Rate in Foldback	(0.5 ± 0.1) sparks/second
Output Voltage (open circuit)	(15 to 20) kV
Output Voltage (typical igniter)	< 8 kV
Output Energy	2 J minimum with 3.0 m (10 ft) leads 1.5 J minimum with 9.8 m (32 ft) leads
Output Energy Duration	50 μs
Peak Spark Pulse Power	50 000 W minimum
Peak Spark Pulse Current	1200 A minimum
Ambient Temperatures	(–20 to +70) °C / (–4 to +158) °F
Diagnostic Output	Normally open relay output, 125 V(DC), 0.3 A
Max Combustor Mounting Temperature (at ignitors)	480C
Max Combustor Pressure (at ignitors)	2800 kPa

IMPORTANT

The exciter outputs are intended for use with high tension igniters, coupled via ignition cables having SAE ARP-670 connections. The exciter will mate with a Type 3M connection.

Due to requirements of explosion proof box HV output ports are NPT threaded. To go through the wall of the box special version of cables were prepared by Woodward.

Igniter Cables

The four channel STExcite control is designed to be used only with the following ignition cables:

Table 2-2. Ignition Cable Specifications

Item #	Meters	Feet	Inches
5450-2268	4.00	13.12	157.48 +/- 2.50
5450-2267	3.00	9.84	118.11 +/- 2.50

Ignition cables are rated for up to 100°C (212°F) continuous use on the conduit seals and tested to be compatible with the required igniters for a 480C maximum combustion chamber temperature. The insulator tip is manufactured using alumina ceramic. Nuts and ferrules are 304 or 316 stainless steels.

All igniter cables listed above utilize SAE ARP-670, type 3M connections on both ends. These are intended to be used with igniters manufactured per SAE ARP-670, type 3F. Torque the igniter cable nuts to 14 +/- 1 Nm (125 +/- 10 inch-lbs). Torque should be applied to the nut only while keeping the rest of the assembly from spinning. The lead assembly should be fully extended and positioned before each end is attached and torqued. The system should not be energized during installation and removal. For installation, igniter end connection should always be performed prior to exciter end connection. For removal, exciter end should always be disconnected prior to igniter end.

Exciter end connection ARP-670 kit shall be mounted after the cable goes through the wall of the box.

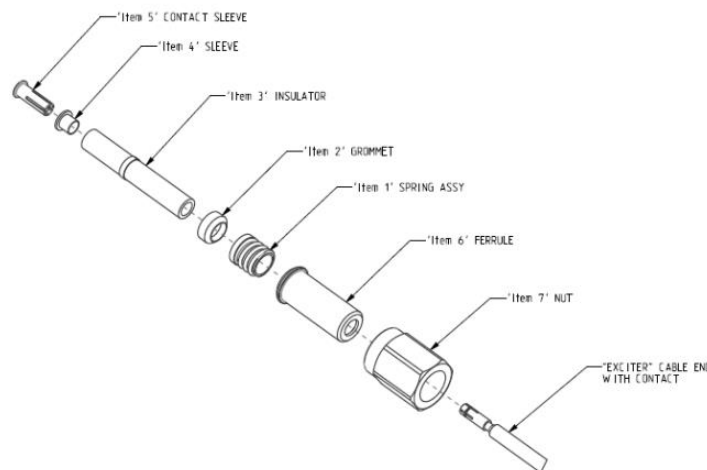

Figure 1-6. STExcite End of Cable Mounting Kit

Igniters

The 4-channel explosion proof ignition system can only be used with ignitor 603P960. These ignitors have been rated for 480C maximum mounting temperature on the combustor. Exceeding this temperature will invalidate the hazardous locations certifications.

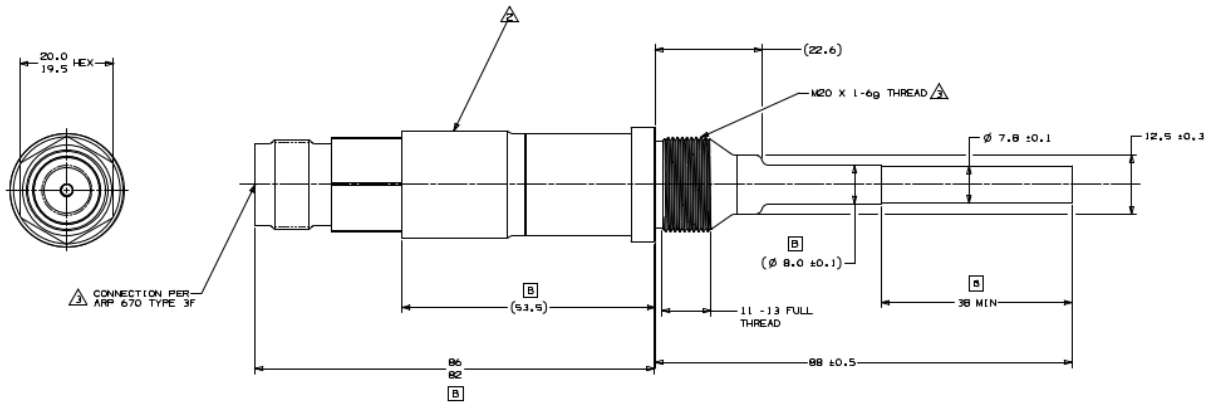

Figure 1-7. 603P960 Igniter

! WARNING

High voltage sparks are generated at the igniter end. Special handling procedures shall be used during maintenance and installation to avoid injury. When a hazardous atmosphere is present, igniters must be mounted to the engine before power is provided to STExcite™ driver.

Chapter 3. Operation and System Description

How to Operate



EXPLOSION HAZARD - Do not apply power to the STExcite™ without first connecting all igniter cable assemblies to both the STExcite™ modules inside a box and to the igniters.



EXPLOSION HAZARD - Do not operate the STExcite™ with the ignition leads shorted to ground. This will cause product damage and can create an explosion hazard.



The four channel industrial gas turbine ignition system driver is not rated for 100% duty cycle operation. The recommended duration of constant ignition firing is 90 seconds followed by 90 seconds of inactivity. If the unit needs to be fired again, the recommended duration of constant ignition firing is 90 seconds followed by 6 minutes of inactivity. The four channel STExcite control automatically reduces the number of ignition events per minute after 120 seconds.

With the exciter properly mounted, the diagnostic output and input ac power connected to the turbine combustion controller, and the output connector connected to igniters using the ignition leads, prepare the turbine for operation following the manufacturer's recommendations. Direct the turbine combustion controller to energize the channel industrial gas turbine ignition system. After the STExcite control is running, direct the turbine combustion controller to turn on the fuel source. Once the combustors are lit, direct the turbine combustion controller to de-energize the STExcite control.

Software Information

All software-configurable parameters are preset by the factory. No user-configurable parameters are available.

Detailed System Description

When power is applied, the power supply converts 230 VAC to 24 VDC. The 24 VDC is converted to system voltages. Once these system voltages are available and the unit passes the self-test, the Digital Signal Processor (DSP) closes the diagnostic output. The DSP then initiates an ignition event.

The DSP monitors the line voltage, the length of time of operation, and internal temperature of the unit to determine if proper operating conditions exist. The unit protects itself by reducing the number of ignition events per minute should adverse conditions occur.

Before input power is applied to the STExcite control, the diagnostic output is in the normally open or de-energized state, indicating that the ignition output is not firing. When nominal input power is applied to the control, the unit energizes the diagnostic output within 0.5 second and fires the first ignition output within 1 second. Under nominal operating conditions, each ignition output fires every 555 ms. The outputs fire out of phase with each other.

Any instrumentation that is monitoring the status of the diagnostic output should take into account whether power has been applied to the STExcite control, along with the status of the diagnostic output. When the control is off (no input power applied), the status of the diagnostic output is the same as when a fault has occurred (de-energized state indicates no ignition output firing).

Monitoring device should check if diagnostic relays state is "Open" when there is no power applied to the modules. If that is not the case, there might be a wiring fault or short of diagnostic relay output. This kind of fault needs to be corrected to avoid loss of diagnostics capability.

The STExcite control monitors many voltages and events within the system. If the unit detects that either ignition channel has failed or there is an abnormal operating condition that prevents the control from generating a spark, the DSP de-energizes the diagnostic output, alerting the turbine combustion controller of a fault. The DSP also shuts down the failed ignition output. There are two diagnostic relay outputs, one for each two channel module.

The following list summarizes the diagnostic output operation:

- The diagnostic output opens (de-energized) when the STExcite control is NOT powered.
- The diagnostic output closes (energized) within 0.5 second of nominal input power application [230 VAC].
- The diagnostic output remains closed (energized) if the STExcite control is powered and firing the ignition output without detecting failures.
- The diagnostic output opens (de-energized) when the exciter detects a critical fault for either of the channels. The channel with the fault detected shuts down while the other channel continues to fire.

If the diagnostic output is open (de-energized) the following may be true:

- Input power has not been applied to the STExcite control (input power relay not energized, input power cable fault, input power relay fault, etc.).
- The input power is less than 160 VAC or greater than 288 VAC.
- There is an ignition lead fault or absence of the ignition lead.
- There is an igniter fault or absence of the igniter.
- The unit has an internal failure that prevents it from generating spark.

Chapter 4. Troubleshooting

⚠ WARNING

SHOCK HAZARD – Do not remove the cover of the STExcite™ while AC power is applied. Hazardous voltages exist within the unit when AC power is applied. Wait 2 minutes after AC power is removed to allow the hazardous voltages to be bled off before opening the cover. Remember to remove power from both power input ports.

⚠ WARNING

Installation and repair should only be attempted by properly trained personnel. Hazardous voltages are present within this unit once AC power has been applied. Failure to observe these warnings could lead to injury or death.

- Remove AC power at circuit breaker.
- Wait 2 minutes for the unit to discharge and become safe.
- Open the unit cover.
- Verify that the ignition lead mounting and high-voltage connections are correct.
- Verify that the diagnostic output connections are correct.
- Verify that the PE ground connection is correct.
- Verify that the AC power connections are correct.
- Replace the unit cover.
- Apply AC power to unit.
- If unit does not function correctly with all connections verified as correct, contact Woodward.

Chapter 5.

Product Support and Service Options

Product Support Options

If you are experiencing problems with the installation, or unsatisfactory performance of a Woodward product, the following options are available:

- Consult the troubleshooting guide in the manual.
- Contact the manufacturer or packager of your system.
- Contact the Woodward Full Service Distributor serving your area.
- Contact Woodward technical assistance (see “How to Contact Woodward” later in this chapter) and discuss your problem. In many cases, your problem can be resolved over the phone. If not, you can select which course of action to pursue based on the available services listed in this chapter.

OEM or Packager Support: Many Woodward controls and control devices are installed into the equipment system and programmed by an Original Equipment Manufacturer (OEM) or Equipment Packager at their factory. In some cases, the programming is password-protected by the OEM or packager, and they are the best source for product service and support. Warranty service for Woodward products shipped with an equipment system should also be handled through the OEM or Packager. Please review your equipment system documentation for details.

Woodward Business Partner Support: Woodward works with and supports a global network of independent business partners whose mission is to serve the users of Woodward controls, as described here:

- A **Full Service Distributor** has the primary responsibility for sales, service, system integration solutions, technical desk support, and aftermarket marketing of standard Woodward products within a specific geographic area and market segment.
- An **Authorized Independent Service Facility (AISF)** provides authorized service that includes repairs, repair parts, and warranty service on Woodward's behalf. Service (not new unit sales) is an AISF's primary mission.

A current list of Woodward Business Partners is available at:

<https://www.woodward.com/en/support/industrial/service-and-spare-parts/find-a-local-partner>

Product Service Options

The following factory options for servicing Woodward products are available through your local Full-Service Distributor or the OEM or Packager of the equipment system, based on the standard Woodward Product and Service Warranty (5-09-0690) that is in effect at the time the product is originally shipped from Woodward or a service is performed:

- Replacement/Exchange (24-hour service)
- Flat Rate Repair
- Flat Rate Remanufacture

Replacement/Exchange: Replacement/Exchange is a premium program designed for the user who is in need of immediate service. It allows you to request and receive a like-new replacement unit in minimum time (usually within 24 hours of the request), providing a suitable unit is available at the time of the request, thereby minimizing costly downtime. This is a flat-rate program and includes the full standard Woodward product warranty (Woodward Product and Service Warranty 5-09-0690).

This option allows you to call your Full-Service Distributor in the event of an unexpected outage, or in advance of a scheduled outage, to request a replacement control unit. If the unit is available at the time of the call, it can usually be shipped out within 24 hours. You replace your field control unit with the like-new replacement and return the field unit to the Full-Service Distributor.

Charges for the Replacement/Exchange service are based on a flat rate plus shipping expenses. You are invoiced the flat rate replacement/exchange charge plus a core charge at the time the replacement unit is shipped. If the core (field unit) is returned within 60 days, a credit for the core charge will be issued.

Flat Rate Repair: Flat Rate Repair is available for the majority of standard products in the field. This program offers you repair service for your products with the advantage of knowing in advance what the cost will be. All repair work carries the standard Woodward service warranty (Woodward Product and Service Warranty 5-09-0690) on replaced parts and labor.

Flat Rate Remanufacture: Flat Rate Remanufacture is very similar to the Flat Rate Repair option with the exception that the unit will be returned to you in "like-new" condition and carry with it the full standard Woodward product warranty (Woodward Product and Service Warranty 5-09-0690). This option is applicable to mechanical products only.

Returning Equipment for Repair

If a control (or any part of an electronic control) is to be returned for repair, please contact your Full-Service Distributor in advance to obtain Return Authorization and shipping instructions.

When shipping the item(s), attach a tag with the following information:

- Return authorization number
- Name and location where the control is installed
- Name and phone number of contact person
- Complete Woodward part number(s) and serial number(s)
- Description of the problem
- Instructions describing the desired type of repair

Packing a Control

Use the following materials when returning a complete control:

- Protective caps on any connectors
- Antistatic protective bags on all electronic modules
- Packing materials that will not damage the surface of the unit
- At least 100 mm (4 inches) of tightly packed, industry-approved packing material
- A packing carton with double walls
- A strong tape around the outside of the carton for increased strength

NOTICE

To prevent damage to electronic components caused by improper handling, read and observe the precautions in Woodward manual 82715, *Guide for Handling and Protection of Electronic Controls, Printed Circuit Boards, and Modules*.

Replacement Parts

When ordering replacement parts for controls, include the following information:

- The part number(s) (XXXX-XXXX) that is on the enclosure nameplate
- The unit serial number, which is also on the nameplate

Engineering Services

Woodward offers various Engineering Services for our products. For these services, you can contact us by telephone, by email, or through the Woodward website.

- Technical Support
- Product Training
- Field Service

Technical Support is available from your equipment system supplier, your local Full-Service Distributor, or from many of Woodward's worldwide locations, depending upon the product and application. This service can assist you with technical questions or problem solving during the normal business hours of the Woodward location you contact. Emergency assistance is also available during non-business hours by phoning Woodward and stating the urgency of your problem.

Product Training is available as standard classes at many of our worldwide locations. We also offer customized classes, which can be tailored to your needs and can be held at one of our locations or at your site. This training, conducted by experienced personnel, will assure that you will be able to maintain system reliability and availability.

Field Service engineering on-site support is available, depending on the product and location, from many of our worldwide locations or from one of our Full-Service Distributors. The field engineers are experienced both on Woodward products as well as on much of the non-Woodward equipment with which our products interface.

For information on these services, please contact one of the Full-Service Distributors listed at www.woodward.com/local-partner.

Contacting Woodward's Support Organization

For the name of your nearest Woodward Full-Service Distributor or service facility, please consult our worldwide directory at <https://www.woodward.com/support>, which also contains the most current product support and contact information.

You can also contact the Woodward Customer Service Department at one of the following Woodward facilities to obtain the address and phone number of the nearest facility at which you can obtain information and service.

Products Used in Electrical Power Systems

<u>Facility</u>	<u>Phone Number</u>
Brazil	+55 (19) 3708 4800
China	+86 (512) 8818 5515
Germany	+49 (711) 78954-510
India	+91 (124) 4399500
Japan	+81 (43) 213-2191
Korea	+82 (32) 422-5551
Poland	+48 (12) 295 13 00
United States	+1 (970) 482-5811

Products Used in Engine Systems

<u>Facility</u>	<u>Phone Number</u>
Brazil	+55 (19) 3708 4800
China	+86 (512) 8818 5515
Germany	+49 (711) 78954-510
India	+91 (124) 4399500
Japan	+81 (43) 213-2191
Korea	+82 (32) 422-5551
The Netherlands	+31 (23) 5661111
United States	+1 (970) 482-5811

Products Used in Industrial Turbomachinery Systems

<u>Facility</u>	<u>Phone Number</u>
Brazil	+55 (19) 3708 4800
China	+86 (512) 8818 5515
India	+91 (124) 4399500
Japan	+81 (43) 213-2191
Korea	+82 (32) 422-5551
The Netherlands	+31 (23) 5661111
Poland	+48 (12) 295 13 00
United States	+1 (970) 482-5811

Technical Assistance

If you need to contact technical assistance, you will need to provide the following information. Please write it down here before contacting the Engine OEM, the Packager, a Woodward Business Partner, or the Woodward factory:

General

Your Name _____

Site Location _____

Phone Number _____

Fax Number _____

Prime Mover Information

Manufacturer _____

Turbine Model Number _____

Type of Fuel (gas, steam, etc.) _____

Power Output Rating _____

Application (power generation, marine,
etc.) _____

Control/Governor Information

Control/Governor #1

Woodward Part Number & Rev. Letter _____

Control Description or Governor Type _____

Serial Number _____

Control/Governor #2

Woodward Part Number & Rev. Letter _____

Control Description or Governor Type _____

Serial Number _____

Control/Governor #3

Woodward Part Number & Rev. Letter _____

Control Description or Governor Type _____

Serial Number _____

Symptoms

Description _____

If you have an electronic or programmable control, please have the adjustment setting positions or the menu settings written down and with you at the time of the call.

Revision History

Changes in Revision A

- Additions to specific conditions of use for IECEx and ATEX for igniter (Regulatory Compliance)
- Mac combustor pressure at ignitors added to Specifications Table 2-1
- Added DoC

Changes in Revision –

- New manual

Declarations

EU DECLARATION OF CONFORMITY

EU DoC No.: 00662-EU-02-02
Manufacturer's Name: WOODWARD POLAND SP. Z O. O.
Manufacturer's Contact Address: Skarbowa 32
 32-005 Niepolomice, Poland
Model Name(s)/Number(s): STExcite Ignition System, P/N 8408-9001
The object of the declaration described above is in conformity with the following relevant Union harmonization legislation: Directive 2014/34/EU of the European Parliament and of the Council of 26 February 2014 on the harmonization of the laws of the Member States relating to equipment and protective systems intended for use in potentially explosive atmospheres
 Directive 2014/30/EU of the European Parliament and of the Council of 26 February 2014 on the harmonization of the laws of the Member States relating to electromagnetic compatibility (EMC)
Markings in addition to CE marking:  II 2 G, Ex db IIB+H2 T4 Gb
Applicable Standards:
ATEX: EN IEC 60079-0:2018 – Explosive atmospheres – Part 0: Equipment – General requirements
 EN 60079-1:2014 – Explosive atmospheres – Part 1: Equipment protection by flameproof enclosures “d”
EMC: EN 61000-6-2:2005, EN 61000-6-2:2005/AC:2005 Electromagnetic compatibility (EMC) - Part 6-2: Generic standards - Immunity for industrial environments
 EN 61000-6-4:2007, EN 61000-6-4:2007/A1:2011 Electromagnetic compatibility (EMC) - Part 6-4: Generic standards - Emission standard for industrial environments
Third Party Certification: ETL23ATEX0302X
 Intertek Testing Services NA, Inc. (2903)
 14920-135 Ave, Edmonton, AB, T5V 1R9 CANADA
Conformity Assessment: ATEX Annex IV - Production Quality Assessment, 01 220 1809016
 TUV Rheinland Industrie Service GmbH (0035)
 Am Grauen Stein, D51105 Cologne

Woodward EMC Conformity Assessment 00662-EU-EMC-06-01

This declaration of conformity is issued under the sole responsibility of the manufacturer
 We, the undersigned, hereby declare that the equipment specified above conforms to the above Directive(s).

MANUFACTURER



Signature

Joseph Driscoll

Full Name

Engineering Manager

Position

Woodward, Fort Collins, CO, USA

Place

12/13/23

Date

We appreciate your comments about the content of our publications.

Send comments to: industrial.support@woodward.com

Please reference publication **35220**.



PO Box 1519, Fort Collins CO 80522-1519, USA
1041 Woodward Way, Fort Collins CO 80524, USA
Phone +1 (970) 482-5811

Email and Website—www.woodward.com

Woodward has company-owned plants, subsidiaries, and branches, as well as authorized distributors and other authorized service and sales facilities throughout the world.

Complete address / phone / fax / email information for all locations is available on our website.