

37939F



DTSC-200A ATS Controller - Installation



Installation

Release 1.2 – 0

**WARNING**

Read this entire manual and all other publications pertaining to the work to be performed before installing, operating, or servicing this equipment. Practice all plant and safety instructions and precautions. Failure to follow instructions can cause personal injury and/or property damage.

The engine, turbine, or other type of prime mover should be equipped with an overspeed (overtemperature, or overpressure, where applicable) shutdown device(s), that operates totally independently of the prime mover control device(s) to protect against runaway or damage to the engine, turbine, or other type of prime mover with possible personal injury or loss of life should the mechanical-hydraulic governor(s) or electric control(s), the actuator(s), fuel control(s), the driving mechanism(s), the linkage(s), or the controlled device(s) fail.

Any unauthorized modifications to or use of this equipment outside its specified mechanical, electrical, or other operating limits may cause personal injury and/or property damage, including damage to the equipment. Any such unauthorized modifications: (i) constitute “misuse” and/or “negligence” within the meaning of the product warranty thereby excluding warranty coverage for any resulting damage, and (ii) invalidate product certifications or listings.

**CAUTION**

To prevent damage to a control system that uses an alternator or battery-charging device, make sure the charging device is turned off before disconnecting the battery from the system.

Electronic controls contain static-sensitive parts. Observe the following precautions to prevent damage to these parts.

- Discharge body static before handling the control (with power to the control turned off, contact a grounded surface and maintain contact while handling the control).
- Avoid all plastic, vinyl, and Styrofoam (except antistatic versions) around printed circuit boards.
- Do not touch the components or conductors on a printed circuit board with your hands or with conductive devices.

**OUT-OF-DATE PUBLICATION**

This publication may have been revised or updated since this copy was produced. To verify that you have the latest revision, be sure to check the Woodward website:

<http://www.woodward.com/pubs/current.pdf>

The revision level is shown at the bottom of the front cover after the publication number. The latest version of most publications is available at:

<http://www.woodward.com/publications>

If your publication is not there, please contact your customer service representative to get the latest copy.

Important definitions**WARNING**

Indicates a potentially hazardous situation that, if not avoided, could result in death or serious injury.

**CAUTION**

Indicates a potentially hazardous situation that, if not avoided, could result in damage to equipment.

**NOTE**

Provides other helpful information that does not fall under the warning or caution categories.

Woodward reserves the right to update any portion of this publication at any time. Information provided by Woodward is believed to be correct and reliable. However, Woodward assumes no responsibility unless otherwise expressly undertaken.

© Woodward
All Rights Reserved.

Revision History

Rev.	Date	Editor	Changes
F	2025-04-29	Koe	SW Release 1.2-0 and higher Document update <ul style="list-style-type: none"> Added ethernet option
E	2025-02-11	Ma	Document update <ul style="list-style-type: none"> Earthing star-connection corrected (figure 4-2)
D	2024-05-07	Kb	Document update <ul style="list-style-type: none"> Corrected UL approval in Technical Data Updated email contact
C	2023-14-11	Kb	Document update <ul style="list-style-type: none"> Deleted ambiguous 6200 information at UL
B	2023-30-05	Koe	1.0-4 Bug fix release, SW Handoff 53195 <ul style="list-style-type: none"> Fixed a bug where pressing some keys in the HMI moved the device to a state where it did not open/close breakers anymore fixed a bug where the device sometimes crashed when accessed via ModbusRS485 with an invalid address fixed a bug where the device's nonvolatile parameters were incompletely initialized after first startup, at production site fixed a bug, where display of P/Q/S/I values in the device's HMI was inconsistent between S1 and S2, if current transformers were set to values $\geq 1000A$
A	2022-31-03	Ma	1.0-0 - Based on DTSC-200 V2.0017

Content

CHAPTER 1. GENERAL INFORMATION	6
QR Code	6
CHAPTER 2. ELECTROSTATIC DISCHARGE AWARENESS	7
CHAPTER 3. HOUSING	8
Panel Cutout	8
CHAPTER 4. WIRING DIAGRAM	9
Wiring Diagram (Application)	10
CHAPTER 5. CONNECTIONS	11
General Notes	11
Terminals	13
Power Supply	13
Voltage Measuring (<i>FlexRange</i>)	16
Voltage Measuring: Source 1	16
Voltage Measuring: Source 2	21
Current Measuring	26
Load	26
Discrete Inputs	28
Discrete Inputs:	28
Discrete Outputs	29
Discrete Outputs:	29
Interfaces	30
RS-485 Modbus RTU Slave	30
CAN Bus Interfaces (<i>FlexCAN</i>)	31
Ethernet Interface	32

CHAPTER 6. TECHNICAL DATA	33
CHAPTER 7. ENVIRONMENTAL DATA.....	36
CHAPTER 8. ACCURACY	37

Illustrations and Tables

Illustrations

Figure 3-1: Housing - panel-board cutout	8
Figure 4-1: Wiring diagram	9
Figure 5-1: Back panel print	13
Figure 5-2: Voltage measuring - terminal assignment - source 1 voltage	16
Figure 5-3: Voltage measuring -source 1 PT windings, 3Ph 4W	17
Figure 5-4: Voltage measuring -source 1 measuring inputs, 3Ph 4W	17
Figure 5-5: Voltage measuring - source 1 PT windings, 3Ph 3W	18
Figure 5-6: Voltage measuring -source 1 measuring inputs, 3Ph 3W	18
Figure 5-7: Voltage measuring - source 1 PT windings, 1Ph 3W	19
Figure 5-8: Voltage measuring -source 1 measuring inputs, 1Ph 3W	19
Figure 5-9: Voltage measuring - source 1 PT windings, 1Ph 2W	20
Figure 5-10: Voltage measuring -source 1 measuring inputs, 1Ph 2W	20
Figure 5-11: Voltage measuring - source 2	21
Figure 5-12: Voltage measuring - source 2 PT windings, 3Ph 4W	22
Figure 5-13: Voltage measuring -source 2 measuring inputs, 3Ph 4W	22
Figure 5-14: Voltage measuring - source 2 PT windings, 3Ph 3W	23
Figure 5-15: Voltage measuring -source 2 measuring inputs, 3Ph 3W	23
Figure 5-16: Voltage measuring - source 2 PT windings, 1Ph 3W	24
Figure 5-17: Voltage measuring -source 2 measuring inputs, 1Ph 3W	24
Figure 5-18: Voltage measuring - source 2 PT windings, 1Ph 2W	25
Figure 5-19: Voltage measuring -source 2 measuring inputs, 1Ph 2W	25
Figure 5-20: Current measuring – load	26
Figure 5-21: Current measuring - load, L1 L2 L3	27
Figure 5-22: Current measuring - load, Phase Lx	27
Figure 5-23: Discrete inputs - alarm/control inputs - operation logic	28
Figure 5-24: Interface.....	30
Figure 5-25: RS-485 Modbus - connection for half-duplex operation	30
Figure 5-26: Interfaces - CAN bus (<i>FlexCAN</i>).....	31
Figure 5-27: Interfaces - CAN bus - wiring of shielding.....	31

Tables

Table 1-1: Manual - overview	6
Table 5-1: Conversion chart - wire size	11
Table 5-2: Application Example – Wiring Diagram	15
Table 5-3: Voltage measuring - terminal assignment - source 1	16
Table 5-4: Voltage measuring - terminal assignment - source 1, 3ph 4w	17
Table 5-5: Voltage measuring - terminal assignment - source 1, 3Ph 3W	18
Table 5-6: Voltage measuring - terminal assignment - source 1, 1Ph 3W	19
Table 5-7: Voltage measuring - terminal assignment - source 1, 1Ph 2W	20
Table 5-8: Voltage measuring - terminal assignment - source 2 voltage.....	21
Table 5-9: Voltage measuring - terminal assignment - source 2, 3Ph 4W	22
Table 5-10: Voltage measuring - terminal assignment - source 2, 3Ph 3W	23
Table 5-11: Voltage measuring - terminal assignment - source 2, 1Ph 3W	24
Table 5-12: Voltage measuring - terminal assignment - source 2, 1Ph 2W	25
Table 5-13: Current measuring - terminal assignment - load current.....	26
Table 5-14: Current measuring - terminal assignment - load, L1 L2 L3	27
Table 5-15: Current measuring - terminal assignment - load, Phase Lx.....	27
Table 5-16: RS-485 Modbus interface - terminal assignment.....	30
Table 5-17: CAN bus interface - terminal assignment	31
Table 5-18: Maximum CAN bus length.....	32

Chapter 1.

General Information

Type	English	German
DTSC-200A		
DTSC-200A - Installation	this manual ⇔	37939
DTSC-200A - Configuration		37940
DTSC-200A - Operation		37941
DTSC-200A - Application		37942
DTSC-200A - Interfaces		37943

Table 1-1: Manual - overview

Intended Use: The unit must only be operated in the manner described by this manual. The prerequisite for a proper and safe operation of the product is correct transportation, storage, and installation as well as careful operation and maintenance.



NOTE

This manual has been developed for a unit fitted with all available options. Inputs/outputs, functions, configuration screens, and other details described, which do not exist on your unit, may be ignored.

The present manual has been prepared to enable the installation and commissioning of the unit. Due to the large variety of parameter settings, it is not possible to cover every combination. The manual is therefore only a guide. In case of incorrect entries or a total loss of functions, the default settings may be taken from the list of parameters enclosed in the configuration manual.

QR Code



To get access to the complete product documentation, scan this QR code or use the following link:

→ <http://wwdmanuals.com/dtsc-200a>

Chapter 2.

Electrostatic Discharge Awareness

All electronic equipment is static-sensitive, some components more than others. To protect these components from static damage, you must take special precautions to minimize or eliminate electrostatic discharges.

Follow these precautions when working with or near the control.

1. Before doing maintenance on the electronic control, discharge the static electricity on your body to ground by touching and holding a grounded metal object (pipes, cabinets, equipment, etc.).
2. Avoid the build-up of static electricity on your body by not wearing clothing made of synthetic materials. Wear cotton or cotton-blend materials as much as possible because these do not store static electric charges as easily as synthetics.
3. Keep plastic, vinyl, and Styrofoam materials (such as plastic or Styrofoam cups, cigarette packages, cellophane wrappers, vinyl books or folders, plastic bottles, etc.) away from the control, modules, and work area as much as possible.
4. **Opening the control cover may void the unit warranty.**
Do not remove the printed circuit board (PCB) from the control cabinet unless absolutely necessary. If you must remove the PCB from the control cabinet, follow these precautions:
 - Ensure that the device is completely voltage-free (all connectors have to be disconnected).
 - Do not touch any part of the PCB except the edges.
 - Do not touch the electrical conductors, connectors, or components with conductive devices or with bare hands.
 - When replacing a PCB, keep the new PCB in the plastic antistatic protective bag it comes in until you are ready to install it. Immediately after removing the old PCB from the control cabinet, place it in the antistatic protective bag.



CAUTION

To prevent damage to electronic components caused by improper handling, read and observe the precautions in Woodward manual 82715, *Guide for Handling and Protection of Electronic Controls, Printed Circuit Boards, and Modules*.

Chapter 3. Housing

Panel Cutout

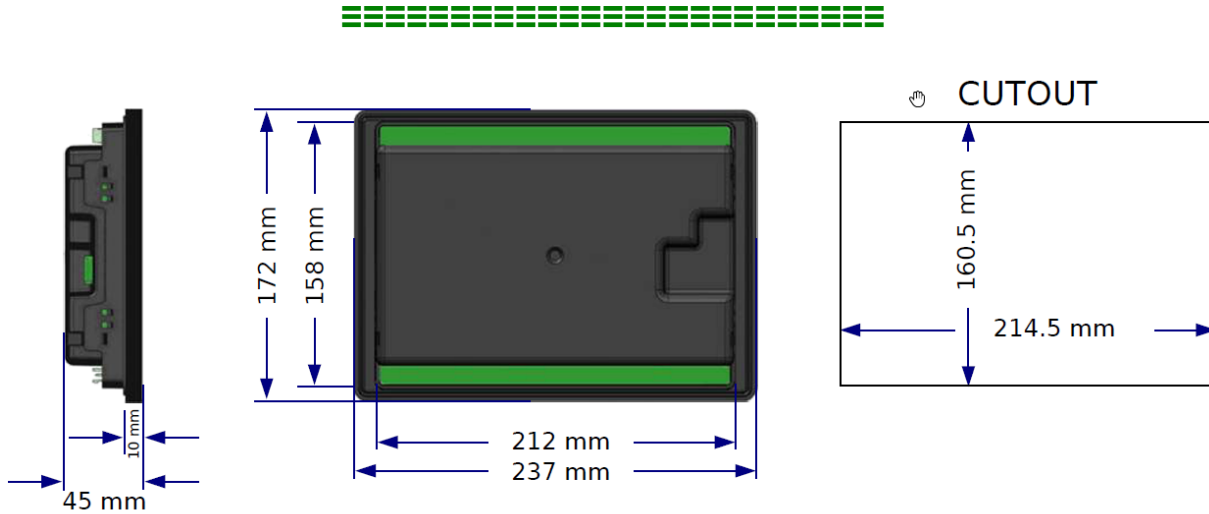

Figure 3-1: Housing - panel-board cutout

Wiring Diagram (Application)

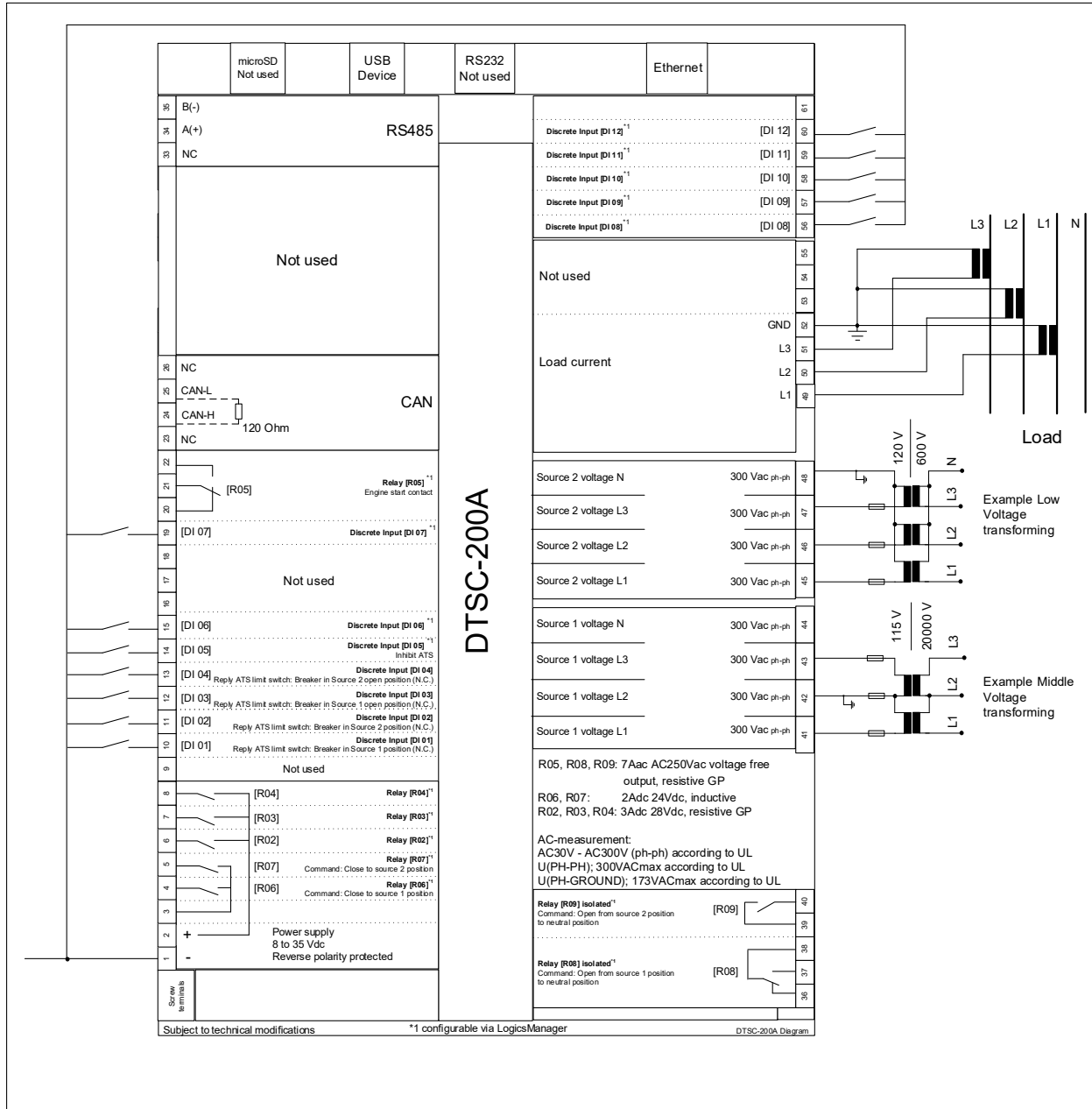

Figure 4-2: Application Example – Wiring Diagram (Application)

Chapter 5. Connections



WARNING

All technical data and ratings indicated in this chapter are not definite! Only the values indicated in Chapter 6: Technical Data on page 33 are valid!

The following chart may be used to convert square millimeters [mm²] to AWG and vice versa:

AWG	mm ²	AWG	mm ²	AWG	mm ²	AWG	mm ²	AWG	mm ²	AWG	mm ²
30	0.05	21	0.38	14	2.5	4	25	3/0	95	600MCM	300
28	0.08	20	0.5	12	4	2	35	4/0	120	750MCM	400
26	0.14	18	0.75	10	6	1	50	300MCM	150	1000MCM	500
24	0.25	17	1.0	8	10	1/0	55	350MCM	185		
22	0.34	16	1.5	6	16	2/0	70	500MCM	240		

Table 5-1: Conversion chart - wire size

General Notes

CAUTION!



Digital (Relays) Outputs

To prevent the controller from damage:

For DC current relays: Attach freewheeling diodes at both ends of relay's coils.

For AC current relays: Increase resistance of the return circuit of the relays coils.



Current input of controller must be connected to the according current transformer secondary side (current is 5 A).
Phases of current transformer and input voltage must be correct. Otherwise, the current of collecting power and active power maybe not correct.

WARNING!



If there is a load current, opening the circuit of the output side of the transformer is not allowed!

CAUTION!



Withstand Voltage Test

Disconnect all terminal connections before performing a high-voltage test of the installed controller.

CAUTION!

All inputs and outputs besides the source 1 and source 2 Voltage terminals of each model shall only be connected to limited voltage circuits, and shall be protected by a maximum 2 A DC rated fuse.



Use min. 90°C copper conductors only.

Field wiring terminals marking:



Shall be marked with AWG wire range and terminal torque rating.

Installed in accordance with the NEC (United States) or the CEC (Canada).

Current sense inputs shall be marked: "From Listed or R/C (XODW2.8) current transformers".

Connections shall be made with 75°C rated wire minimum.

Terminals

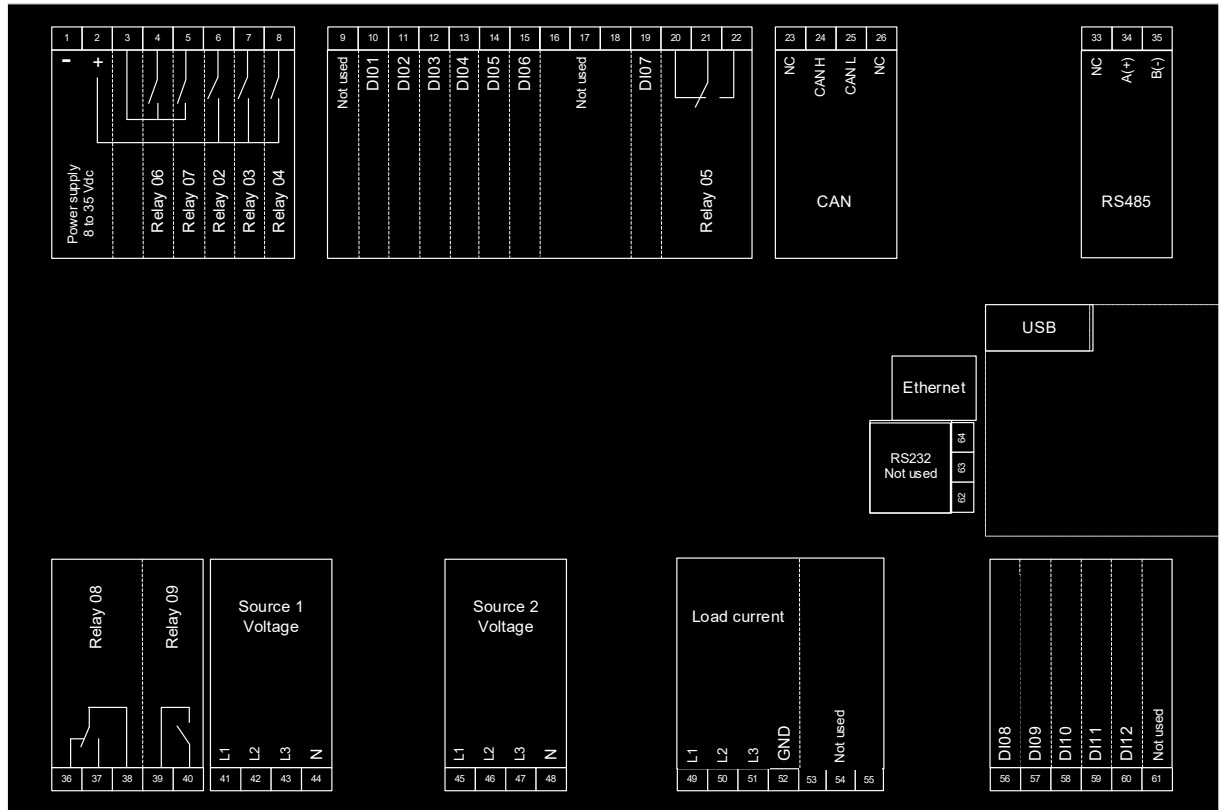

Figure 5-1: Back panel print

Power Supply

The device is prepared for 12Vdc and 24Vdc systems. For more information refer to the technical data.



NOTE

The DTSC-200A operation is internally defined through the measured power supply (terminal 1,2). If the power supply falls under 7.8 Volts the DTSC-200A goes into a passive condition. That means it switches off all relay outputs, shows "low battery" on display and causes the "Alarm" LED to fast blinking. Recovers the power supply again to a value higher 8.5 Volt the device executes a CPU RESET and re-starts again.

No.	Function	Cable Size	Remarks
1	POWER SUPPLY -	2.5mm ²	Connected with the power supply negative
2	POWER SUPPLY +	2.5mm ²	Connected power supply positive. If the wire is longer than 30 m, use double wires in parallel. LPS, Class 2, LVLE, Listed DC fuse 4 A for 24 Vdc circuits is recommended.
3	Common R6,R7	1.5mm ²	Common potential for relay 6 and 7
4	Relay 6	1.5mm ²	Command: Close to source 1 position
5	Relay 7	1.5mm ²	Command: Close to source 2 position
6	Relay 2	1.5mm ²	Free purposes relay 2
7	Relay 3	1.5mm ²	Free purposes relay 3
8	Relay 4	1.5mm ²	Free purposes relay 4
9	Not used		
10	Digital input 1	1.0mm ²	Reply ATS limit switch: Breaker in Source 1 position (N.C.)
11	Digital input 2	1.0mm ²	Reply ATS limit switch: Breaker in Source 2 position (N.C.)
12	Digital input 3	1.0mm ²	Reply ATS limit switch: Breaker in Source 1 open position (N.C.)
13	Digital input 4	1.0mm ²	Reply ATS limit switch: Breaker in Source 2 open position (N.C.)
14	Digital input 5	1.0mm ²	Inhibit ATS
15	Digital input 6	1.0mm ²	Free purposes digital input
16			
17	Not used		
18			
19	Digital input 7	1.0mm ²	Free purposes digital input
20	Relay 5 NC	1.5mm ²	Engine start contact
21	Relay 5 Common	1.5mm ²	
22	Relay 5 NO	1.5mm ²	
23	Not connected		
24	CAN-H	0.5mm ²	CAN Bus: Internal 120 Ω already internally installed. Take the DTSC-200A device as the last or first device in your CAN network.
25	CAN-L	0.5mm ²	
26	Not connected		
33	Not connected		
34	A(+)	0.5mm ²	RS485 half-duplex: Impedance-120 Ω shielding wire is recommended, its single-end grounded.
35	A(-)	0.5mm ²	
36	Relay 8 NC	2.5mm ²	Command: Open from source 1 position to neutral position
37	Relay 8 NO	2.5mm ²	
38	Relay 8 Common	2.5mm ²	
39	Relay 9	2.5mm ²	Command: Open from source 2 position to neutral position
40		2.5mm ²	
41	Source 1 L1	1.0mm ²	Source 1: Connected to A-phase (2 A fuse is recommended)
42	Source 1 L2	1.0mm ²	Source 1: Connected to B-phase (2 A fuse is recommended)
43	Source 1 L3	1.0mm ²	Source 1: Connected to C-phase (2 A fuse is recommended)
44	Source 1 N	1.0mm ²	Source 1: Connected to N-wire
45	Source 2 L1	1.0mm ²	Source 2: Connected to A-phase (2 A fuse is recommended)
46	Source 2 L2	1.0mm ²	Source 2: Connected to B-phase (2 A fuse is recommended)
47	Source 2 L3	1.0mm ²	Source 2: Connected to C-phase (2 A fuse is recommended)
48	Source 2 N	1.0mm ²	Source 2: Connected to N-wire
49	Load current L1	1.5mm ²	Outside connected to secondary coil of CT in L1 load (rated 5 A)
50	Load current L2	1.5mm ²	Outside connected to secondary coil of CT in L2 load (rated 5 A)
51	Load current L3	1.5mm ²	Outside connected to secondary coil of CT in L3 load (rated 5 A)
52	Load current N	1.5mm ²	Outside connected to secondary coil of current transformer (Rated 5 A)
53			
54	Not used		

55			
56	Digital input 8	1.0mm ²	Free purposes digital input
57	Digital input 9	1.0mm ²	Free purposes digital input
58	Digital input 10	1.0mm ²	Free purposes digital input
59	Digital input 11	1.0mm ²	Free purposes digital input
60	Digital input 12	1.0mm ²	Free purposes digital input
61	Not used		

Table 5-2: Application Example – Wiring Diagram

**NOTE**

Woodward recommends to fuse-protect all lines according to their rated load (rated current).

Voltage Measuring (*FlexRange*)



NOTE
DO NOT use both sets of voltage measuring inputs. The control unit will not measure voltage correctly if the 120 V and 480 V inputs are utilized simultaneously.

NOTE
 Woodward recommends protecting the voltage measuring inputs with slow-acting fuses rated for 2 to 6 A.

Voltage Measuring: Source 1

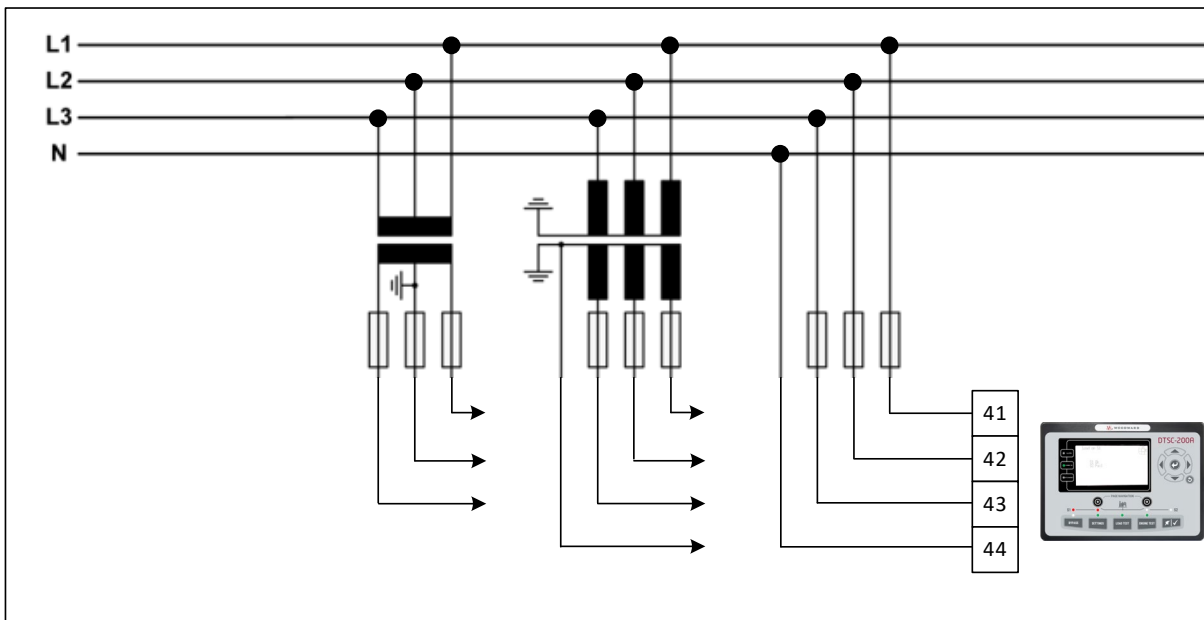

Figure 5-2: Voltage measuring - terminal assignment - source 1 voltage

Terminal	Description	A _{max}
41	Source 1 Voltage L1	2.5 mm ²
42	Source 1 Voltage L2	2.5 mm ²
43	Source 1 Voltage L3	2.5 mm ²
44	Source 1 Voltage N	2.5 mm ²

Table 5-3: Voltage measuring - terminal assignment - source 1

Voltage Measuring: Source 1, Parameter Setting '3Ph 4W' (3-phase, 4-wire)

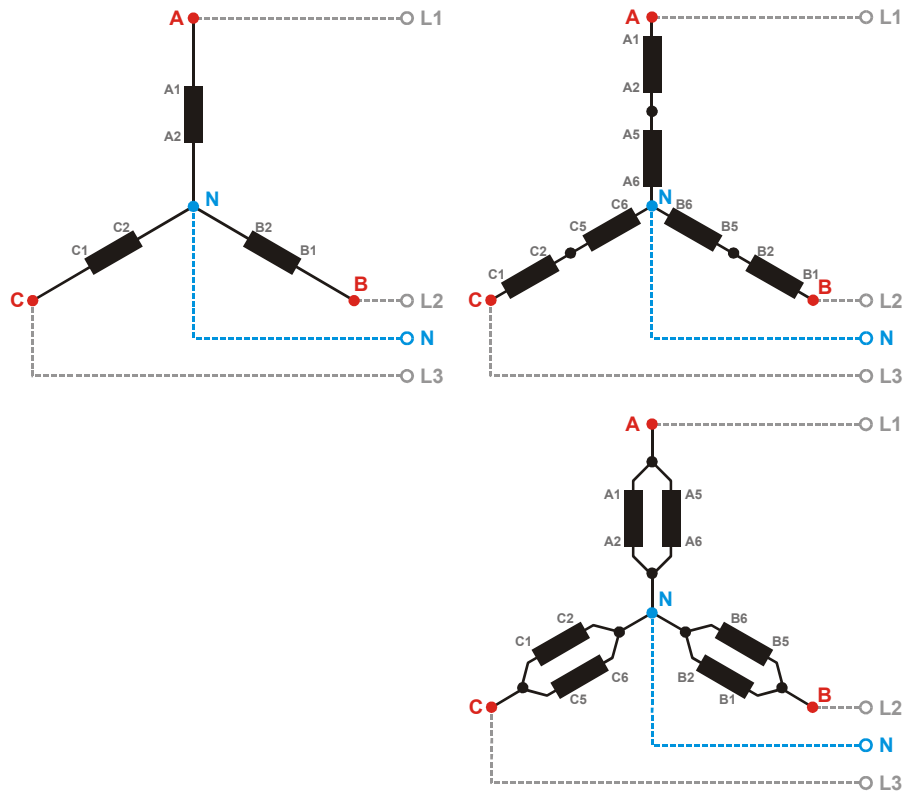

Figure 5-3: Voltage measuring -source 1 PT windings, 3Ph 4W

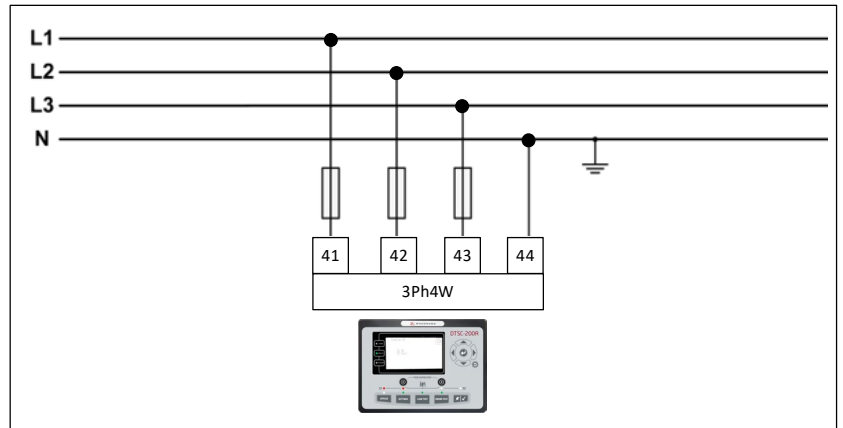

Figure 5-4: Voltage measuring -source 1 measuring inputs, 3Ph 4W

3Ph 4W	Wiring terminals			
DTSC-200A terminal	41	42	43	44
Phase	L1	L2	L3	N

Table 5-4: Voltage measuring - terminal assignment - source 1, 3ph 4w

Voltage Measuring: Source 1, Parameter Setting '3Ph 3W' (3-phase, 3-wire)

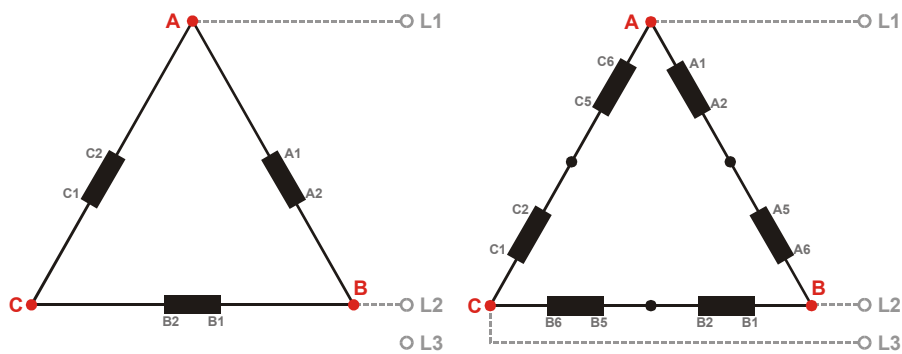

Figure 5-5: Voltage measuring - source 1 PT windings, 3Ph 3W

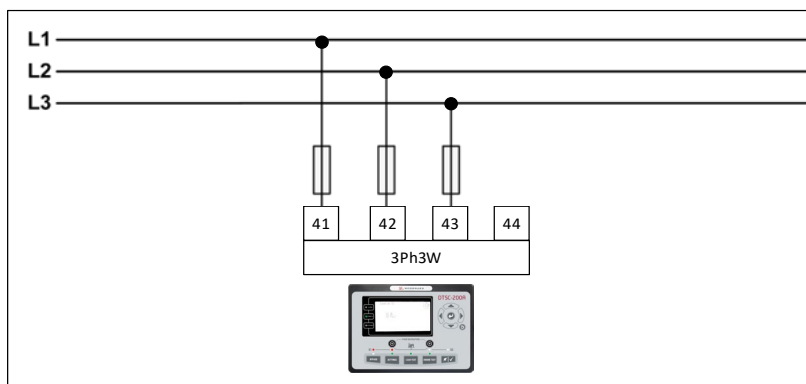

Figure 5-6: Voltage measuring -source 1 measuring inputs, 3Ph 3W

3Ph 3W		Wiring terminals			
DTSC-200A terminal	41	42	43	44	
Phase	L1	L2	L3	-	

Table 5-5: Voltage measuring - terminal assignment - source 1, 3Ph 3W

**NOTE**

If any line input (L1, L2 or L3) is connected to PE or N, the line reactive power (VL1-I1, VL2-I2, and VL3-I3) will not be correctly calculated which results in inaccurate overall reactive power and apparent power calculations. However, single current and overall active (real) power calculations are correct.

Voltage Measuring: Source 1, Parameter Setting '1Ph 3W' (1-phase, 3-wire)

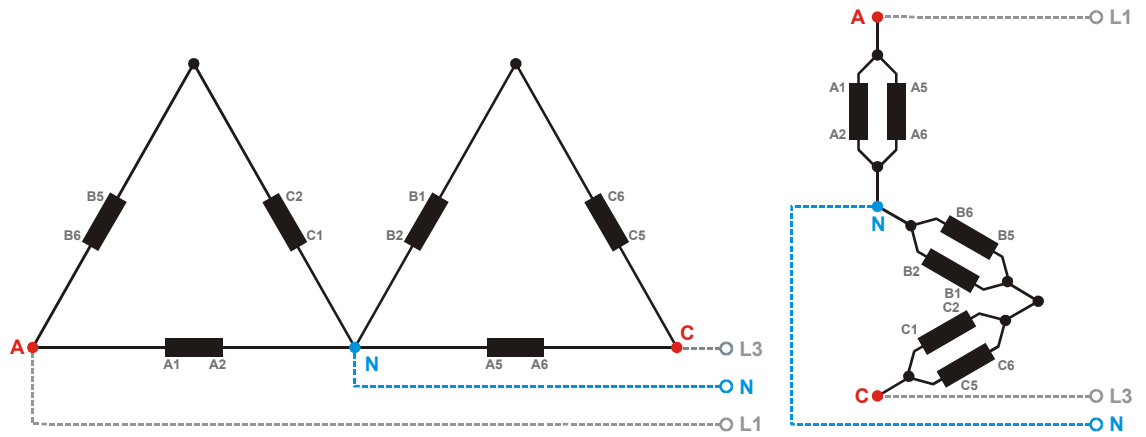

Figure 5-7: Voltage measuring - source 1 PT windings, 1Ph 3W

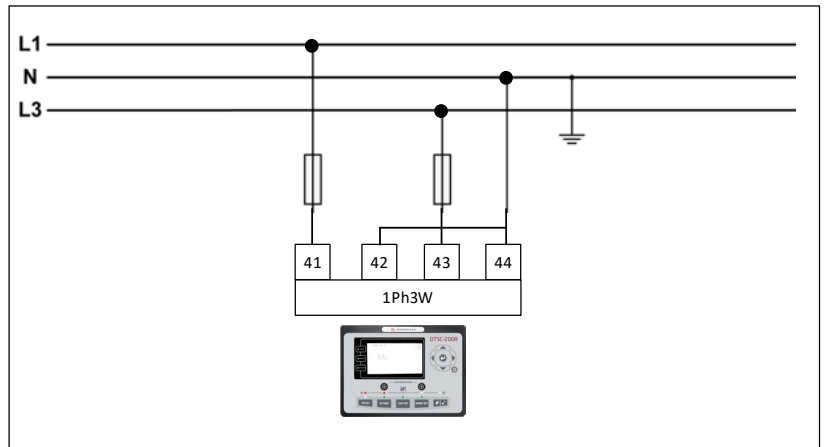

Figure 5-8: Voltage measuring -source 1 measuring inputs, 1Ph 3W

1Ph 3W	Wiring terminals			
DTSC-200A terminal	41	42	43	44
Phase	L1	N	L3	N

Table 5-6: Voltage measuring - terminal assignment - source 1, 1Ph 3W

Voltage Measuring: Source 1, Parameter Setting '1Ph 2W' (1-phase, 2-wire)

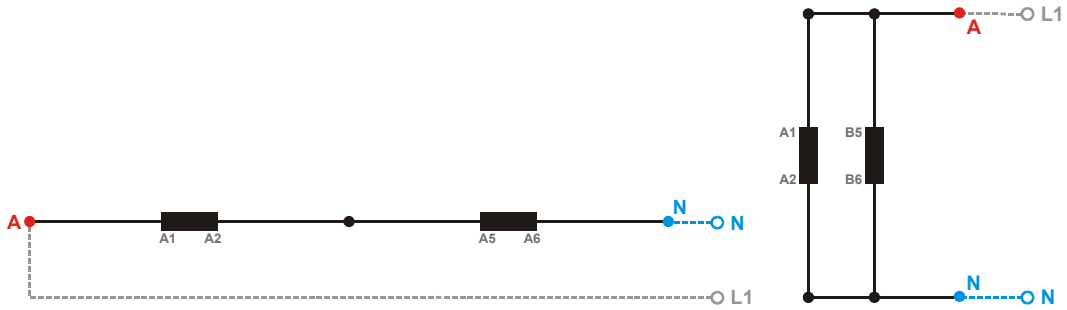

Figure 5-9: Voltage measuring - source 1 PT windings, 1Ph 2W

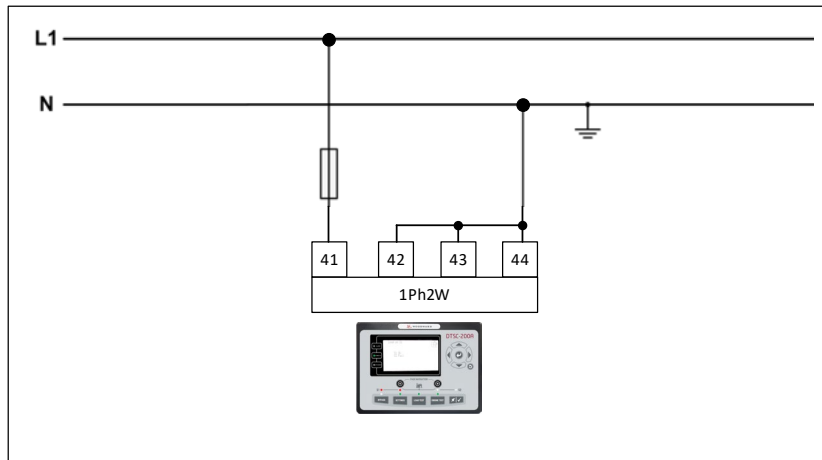

Figure 5-10: Voltage measuring -source 1 measuring inputs, 1Ph 2W

1Ph 2W	Wiring terminals			
DTSC-200A terminal	41	42	43	44
Phase	L1	N	N	N

Table 5-7: Voltage measuring - terminal assignment - source 1, 1Ph 2W

Voltage Measuring: Source 2

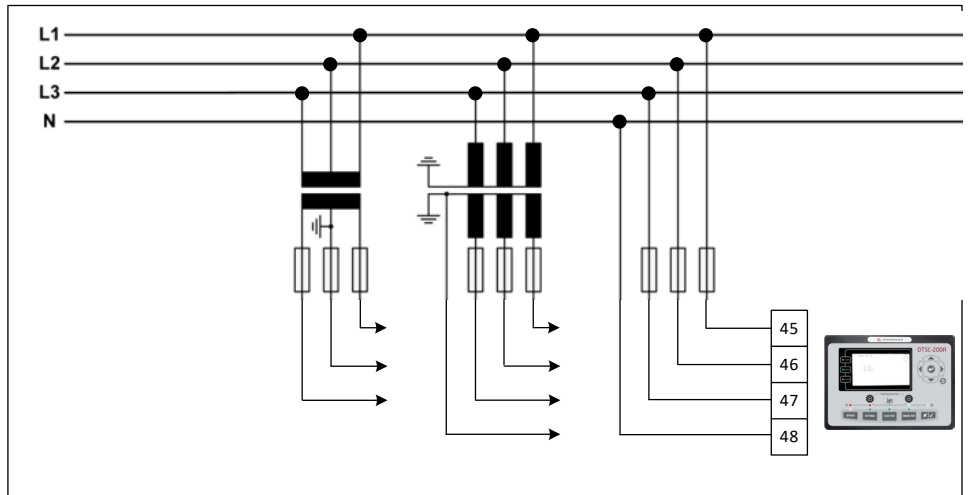

Figure 5-11: Voltage measuring - source 2

Terminal	Description	A_{max}
45	Source 2 Voltage L1	2.5 mm ²
46	Source 2 Voltage L2	2.5 mm ²
47	Source 2 Voltage L3	2.5 mm ²
48	Source 2 Voltage N	2.5 mm ²

Table 5-8: Voltage measuring - terminal assignment - source 2 voltage

Voltage Measuring: Source 2, Parameter Setting '3Ph 4W' (3-phase, 4-wire)

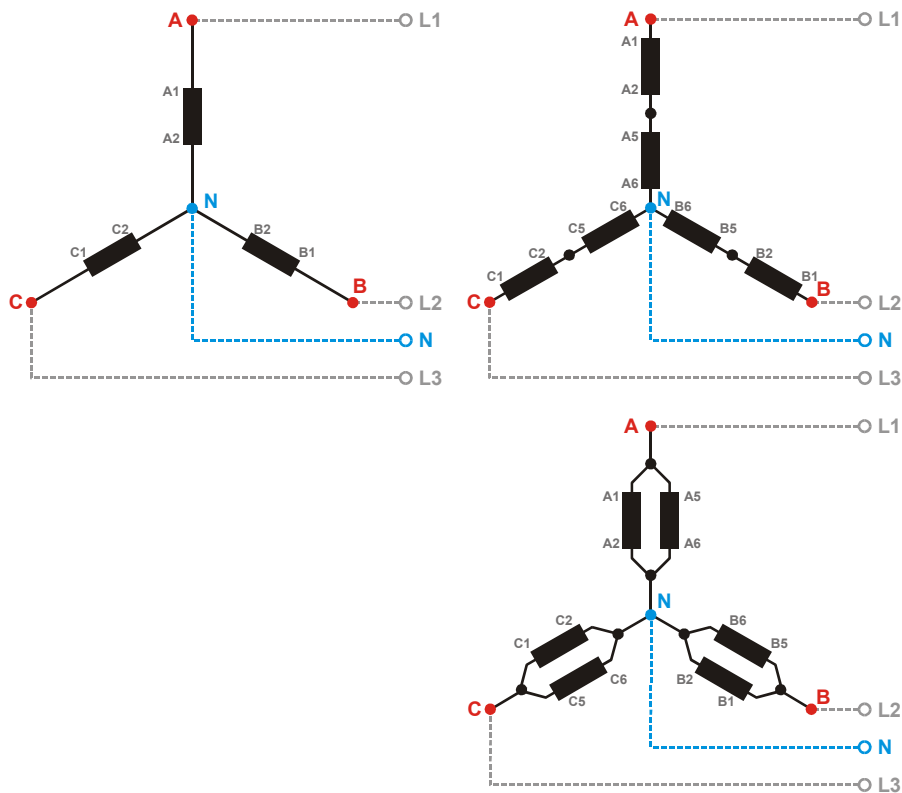

Figure 5-12: Voltage measuring - source 2 PT windings, 3Ph 4W

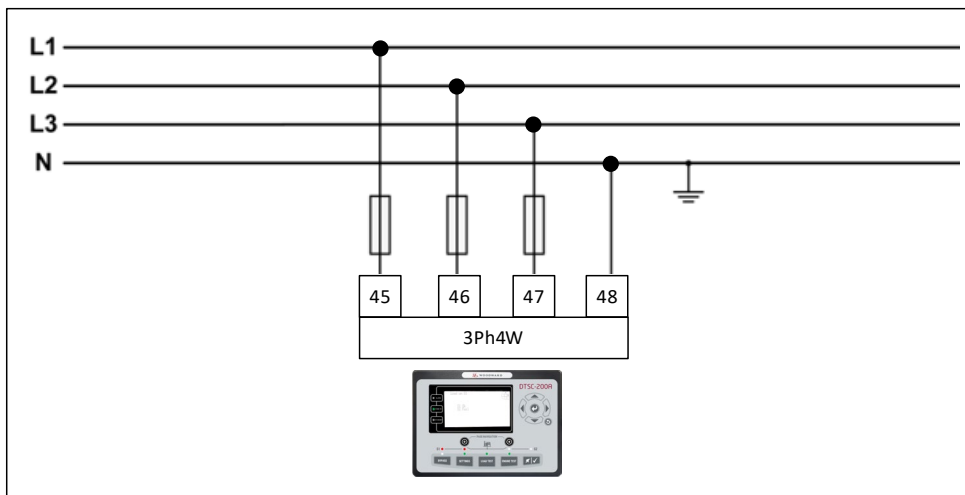

Figure 5-13: Voltage measuring -source 2 measuring inputs, 3Ph 4W

3Ph 4W	Wiring terminals			
DTSC-200A terminal	45	46	47	48
Phase	L1	L2	L3	N

Table 5-9: Voltage measuring - terminal assignment - source 2, 3Ph 4W

Voltage Measuring: Source 2, Parameter Setting '3Ph 3W' (3-phase, 3-wire)

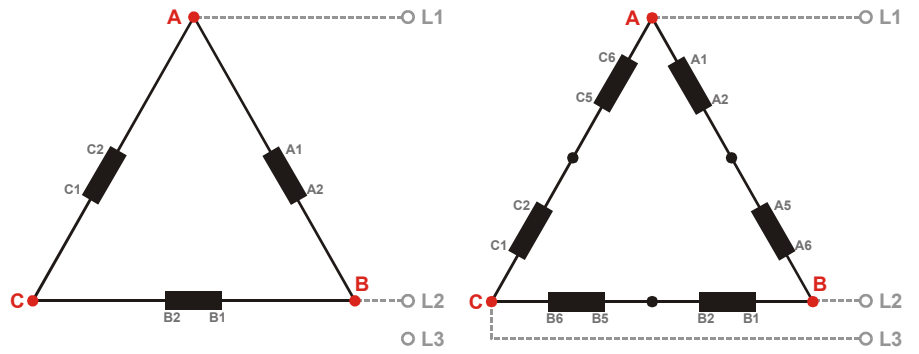

Figure 5-14: Voltage measuring - source 2 PT windings, 3Ph 3W

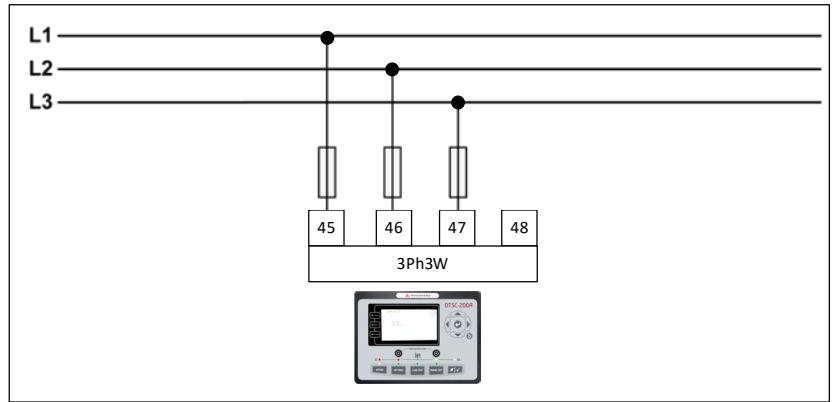

Figure 5-15: Voltage measuring -source 2 measuring inputs, 3Ph 3W

3Ph 3W		Wiring terminals			
DTSC-200A terminal		45	46	47	48
Phase		L1	L2	L3	-

Table 5-10: Voltage measuring - terminal assignment - source 2, 3Ph 3W

Voltage Measuring: Source 2, Parameter Setting '1Ph 3W' (1-phase, 3-wire)

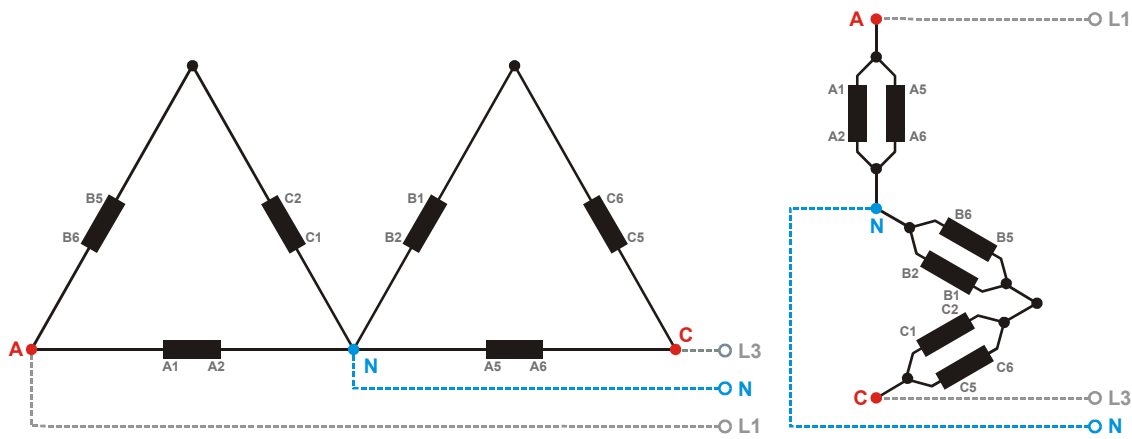

Figure 5-16: Voltage measuring - source 2 PT windings, 1Ph 3W

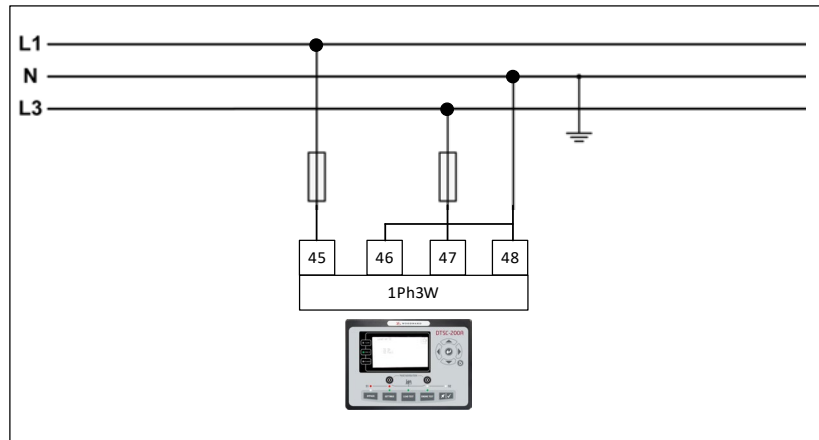

Figure 5-17: Voltage measuring -source 2 measuring inputs, 1Ph 3W

1Ph 3W	Wiring terminals			
DTSC-200A terminal	45	46	47	48
Phase	L1	N	L3	N

Table 5-11: Voltage measuring - terminal assignment - source 2, 1Ph 3W

Voltage Measuring: Source 2, Parameter Setting '1Ph 2W' (1-phase, 2-wire)

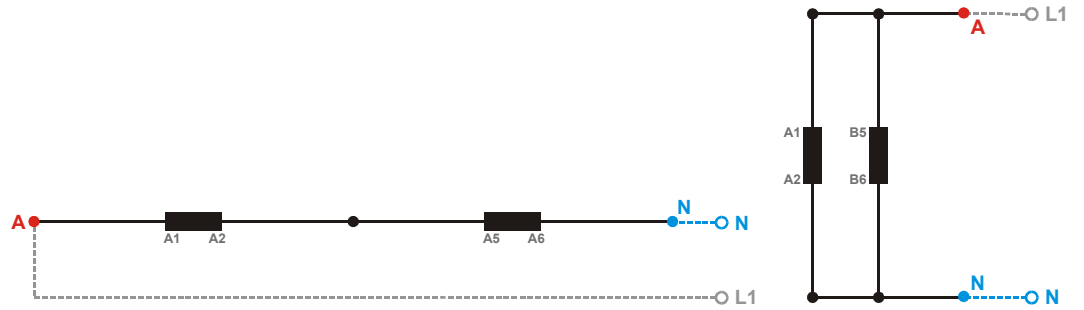

Figure 5-18: Voltage measuring - source 2 PT windings, 1Ph 2W

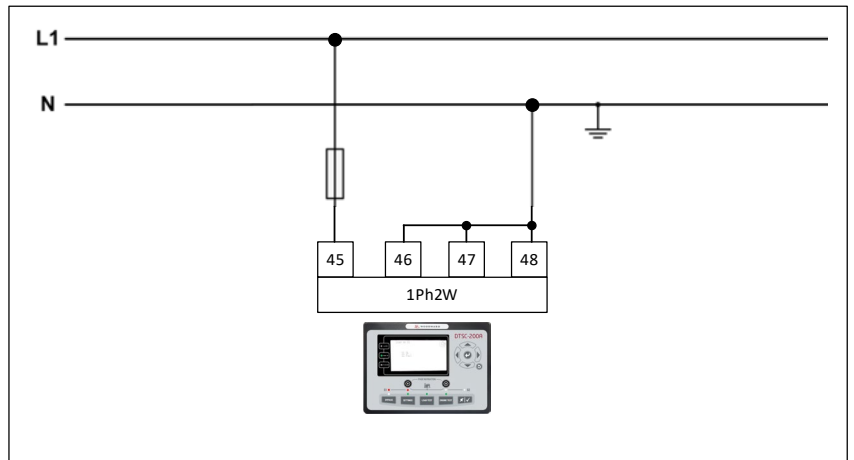

Figure 5-19: Voltage measuring -source 2 measuring inputs, 1Ph 2W

1Ph 2W	Wiring terminals			
DTSC-200A terminal	45	46	47	48
Phase	L1	N	N	N

Table 5-12: Voltage measuring - terminal assignment - source 2, 1Ph 2W

Current Measuring



CAUTION

Before disconnecting the current transformer/CT secondary connections or the connections of the current transformer/CT at the device, ensure that the current transformer/CT is short-circuited.

Load



NOTE

Please connect the wires of the current transformer "L (x)" as near as possible to the unit.



NOTE

Generally, one line of the current transformers secondary is to be grounded.

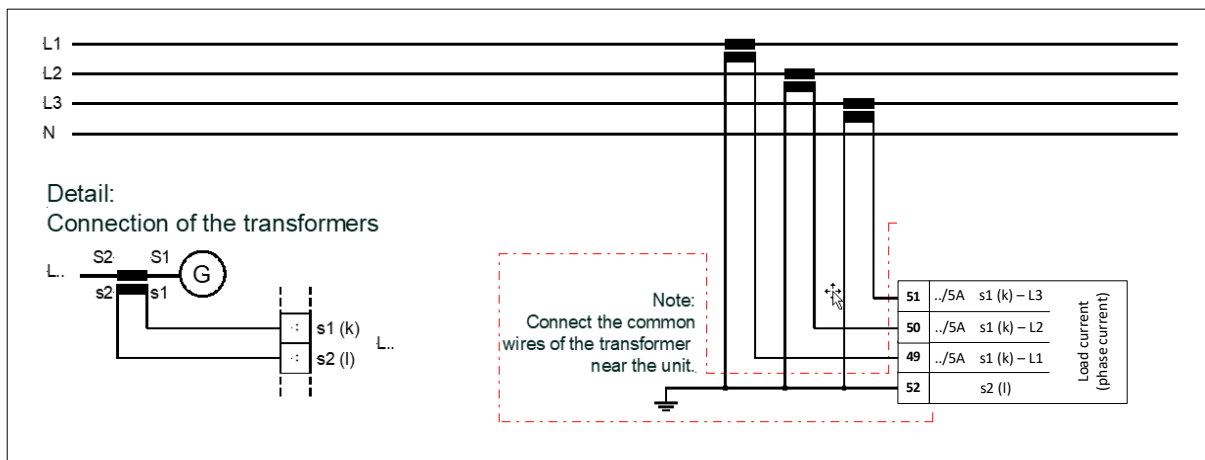

Figure 5-20: Current measuring – load

Terminal	Description	A _{max}
51	Load current - phase L3 - transformer terminal s1 (k)	2.5 mm ²
50	Load current - phase L2 - transformer terminal s1 (k)	2.5 mm ²
49	Load current - phase L1 - transformer terminal s1 (k)	2.5 mm ²
52	Load current - phases L1/L2/L3 - transformer terminals x2 (l)	2.5 mm ²

Table 5-13: Current measuring - terminal assignment - load current

Current Measuring: Load, parameter setting 'L1 L2 L3'

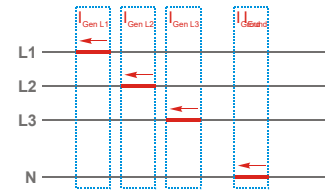

Figure 5-21: Current measuring - load, L1 L2 L3

L1 L2 L3	Wiring terminals				Notes
DTSC-200A	13	12	11	10	
Phase	L1	L2	L3	GND	

Table 5-14: Current measuring - terminal assignment - load, L1 L2 L3

Current Measuring: Load, parameter setting 'Phase L1', 'Phase L2' & 'Phase L3'

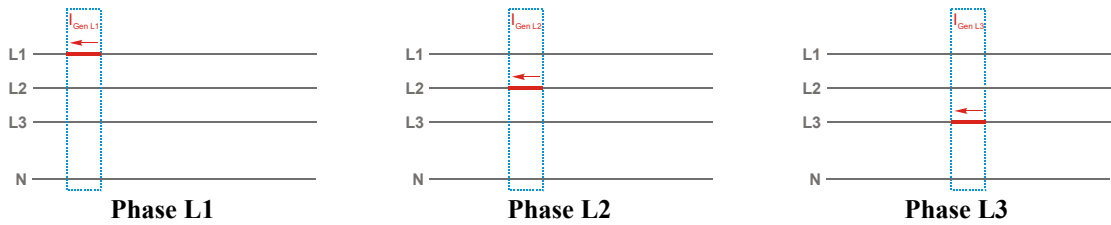

Figure 5-22: Current measuring - load, Phase Lx

	Wiring terminals			
Phase L1				
DTSC-200A	49	50	51	52
Phase	L1	---	---	GND
Phase L2				
DTSC-200A	49	50	51	52
Phase	---	L2	---	GND
Phase L3				
DTSC-200A	49	50	51	52
Phase	---	---	L3	GND

Table 5-15: Current measuring - terminal assignment - load, Phase Lx

Discrete Inputs



Discrete Inputs:

The discrete inputs are switched on ground to energize them. So, there is in some cases no additional power supply required. On the other hand, it is to consider incorporating a couple relay for being potential free. Please have a look on the “Application Example – Wiring Diagram”.



NOTE

The discrete inputs for the breaker position reply messages (DIs 1 through 4) are fixed to N.C. and are evaluated as N.C., i.e. the breaker is considered as “in position” if the respective DI is de-energized.

Discrete Inputs: Operation Logic

Discrete inputs DI 5 to DI 12 may be configured to normally open (N.O.) or normally closed (N.C.) states. In the state N.O., no potential is present during normal operation (condition is de-energized); if a control operation is performed, the input is energized. In the state N.C., a potential is continuously present during normal operation (condition is energized); if a control operation is performed, the input is de-energized.

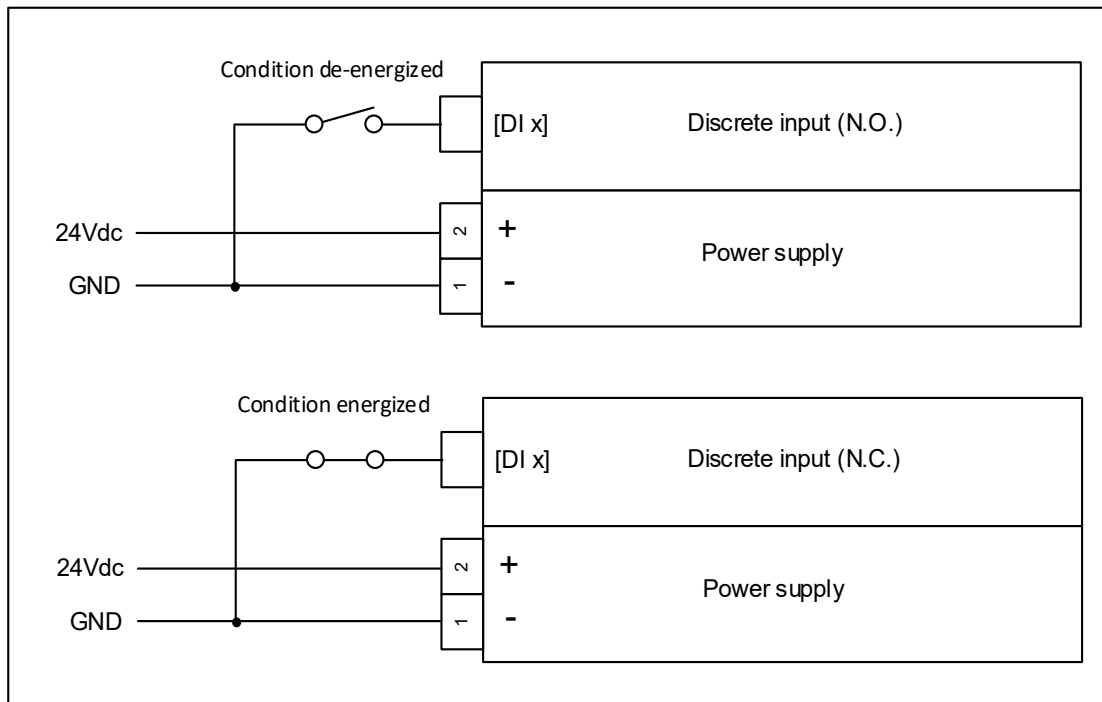

Figure 5-23: Discrete inputs - alarm/control inputs - operation logic

Discrete Outputs



Discrete Outputs:

The discrete outputs are very dedicated and should be studied together with the wiring diagram. The wiring diagram also gives information how are the potentials are combined. Please have a look on the “Application Example – Wiring Diagram”.

Interfaces



RS-485 Modbus RTU Slave

35	B(-)	RS485
34	A(+)	
33	NC	

Figure 5-24: Interface

Description		
34	35	
RS-485-A (TxD+)	RS-485-B (TxD-)	RS-485, Modbus RTU Slave

Table 5-16: RS-485 Modbus interface - terminal assignment

Half-Duplex with Modbus on RS-485

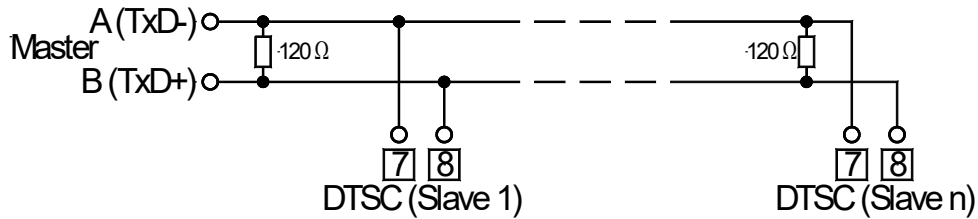

Figure 5-25: RS-485 Modbus - connection for half-duplex operation



NOTE

Please note that the DTSC must be configured for half- duplex configuration (refer to parameter 3173).

CAN Bus Interfaces (*FlexCAN*)

Wiring

Figure 5-26: Interfaces - CAN bus (*FlexCAN*)

Terminal	Description	
24	CAN bus (<i>FlexCAN</i>)	CAN-H
25		CAN-L

Table 5-17: CAN bus interface - terminal assignment

Shielding

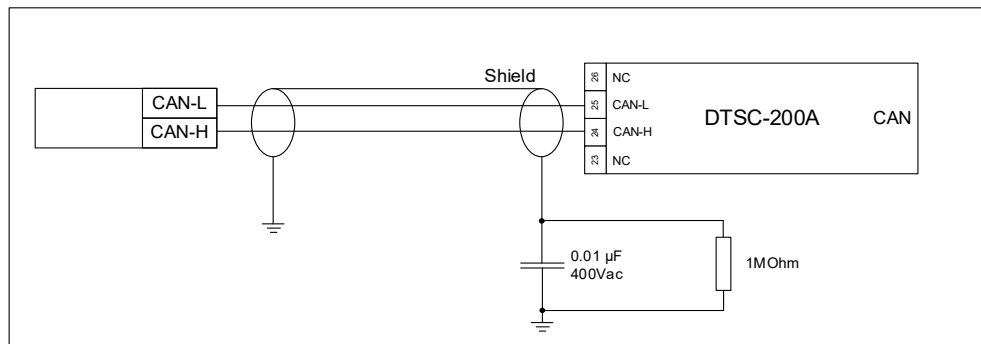

Figure 5-27: Interfaces - CAN bus - wiring of shielding



NOTE

Please note that the CAN bus is internally terminated with a resistor, which corresponds to the impedance of the cable (e.g. 120 Ohms, 1/4 W). It is not possible to connect more than 2 DTSC-200A in a CAN network.

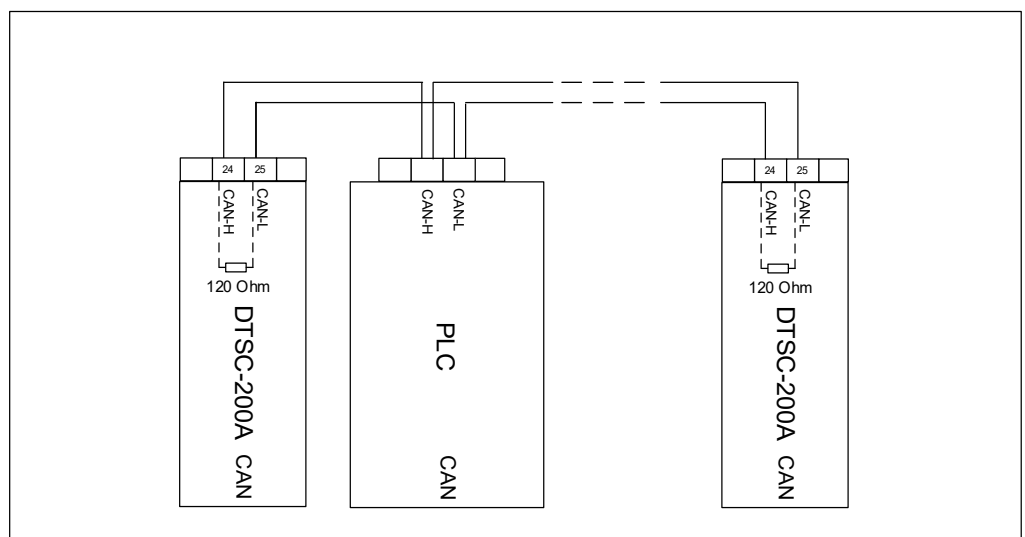

Figure 5-28: Interfaces - CAN bus – termination

**NOTE**

Please note that the DTSC-200A cannot support a CAN Bus baud rate of 800kBits/s.

Possible CAN Bus Problems

If no data is transmitted on the CAN bus, check the following for common CAN bus communication problems:

- T structure bus is utilized
- CAN-L and CAN-H are switched
- Not all devices on the bus are using identical Baud rates
- Termination resistor(s) are missing
- The configured baud rate is too high for wiring length
- The CAN bus cable is co-routed with power cables

Woodward recommends the use of twisted-pair cables for the CAN bus (i.e.: Lappkabel Unitronic LIYCY (TP) 2×2×0.25, UNITRONIC-Bus LD 2×2×0.22).

Maximum CAN bus Length

The maximum length of the communication bus wiring is dependent on the configured Baud rate. Refer to Table 5-18 for the maximum bus length (Source: CANopen; Holger Zeltwanger (Hrsg.); 2001 VDE VERLAG GMBH, Berlin und Offenbach; ISBN 3-8007-2448-0).

Baud rate	Max. length	Comment
1000 kbit/s	25 m	
800 kbit/s	50 m	Not supported in DTSC-200A
500 kbit/s	100 m	
250 kbit/s	250 m	
125 kbit/s	500 m	
50 kbits/s	1000 m	
20 kbit/s	2500 m	

Table 5-18: Maximum CAN bus length

The maximum specified length for the communication bus wiring might not be achieved if poor quality wire is utilized, there is high contact resistance, or other conditions exist. Reducing the baud rate may overcome these issues.

Ethernet Interface**Wiring**

The Ethernet is 10/100Base-T/TX, galvanically isolated, with a standard RJ45 connector. Provided functionality is Modbus/TCP

Chapter 6.

Technical Data

Nameplate

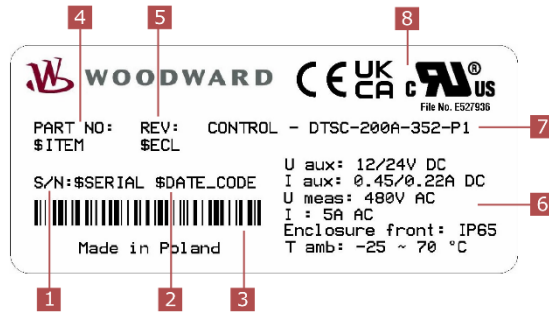

1	S/N	Serial number (numerical)
2	S/N	Date of production (YYMM)
3	S/N	Serial number (Barcode)
4	P/N	Item number
5	REV	Item revision number
6	Details	Technical data
7	Type	Description
8	Approvals	

Measuring values, voltages

- Measuring voltages	Rated value (V_{rated})	277/480 Vac
	Maximum value (V_{max})	max. 358/620 Vac
	Maximum value (V_{max}) according to UL	max. 173/300 Vac
- Linear measuring range		V_{rated}
- Measuring frequency		50/60 Hz (40.0 to 85.0 Hz)
- Accuracy		Class 1
- Input resistance per path		4.0 M Ω
- Maximum power consumption per path		< 0.2 VA

Measuring values, currents

- Measuring current	Rated value (I_{rated})	..5 A
- Accuracy		Class 1
- Linear measuring range	Load (terminals 49 through 52)	$2.0 \times I_{rated}$
- Rated short-time current (1 s)		$10.0 \times I_{rated}$
- From Listed or R/C (XODW2/8) current transformers		

Ambient variables

- Power supply	12/24 Vdc (8 to 35 Vdc)
	Reverse polarity protected
Maximum supply voltage	Short Time 80 V (5-10 s)
	Long Time 50 V
- Maximum operating current	(All relays closed, LCD bright)
	450 mA (12 V)
	220 mA (24 V)
- Maximum standby current	(All relays closed, LCD dim)
	420 mA (12 V)
	200 mA (24 V)
- Power Consumption	<6 W (standby \leq 5 W)

Discrete outputs Group A [R 2-4]

	Rated 7 Adc, 24 Vdc running stand alone,
	rated 3 Adc, 24 Vdc when running in parallel
	with other two relays
	3 Adc 24 Vdc, resistive GP (according to UL)

Discrete outputs [R 5]	isolated
..... 7 Aac 250 Vac voltage free output, resistive GP	
Discrete outputs Group B [R 6-7]	isolated
..... Rated 10 Adc, 24 Vdc running stand alone,	
..... rated 5 Adc, 24 Vdc when running in parallel with the other relay	
..... Rated 2 Adc 24 Vdc, inductive (according to UL)	
Discrete outputs Group C [R 8-9]	isolated
- 7 Aac 250 Vac voltage free output, resistive GP	
Discrete inputs Group A [DI 1-7]	non isolated
- Low level threshold.....	Approx. 1.3 V
- Maximum input voltage	60 V
- Minimum input voltage.....	0 V
- High level threshold	1.7 V
Discrete inputs Group B [DI 8-12]	non isolated
- Low level threshold.....	Approx. 1.3 V
- Maximum input voltage	24 V
- Minimum input voltage.....	0 V
- High level threshold	1.7 V
Interface	
USB Port	
Max. allowed cable length	1.5 m
RS-485 interface	isolated
- Insulation voltage.....	500 Vac
- Version.....	RS-485
- Max. allowed cable length	1000 m
CAN bus interface	isolated
- Insulation voltage.....	500 Vac
- Version.....	CAN bus
- Internal line termination.....	120Ω
Ethernet	
- Galvanically insulated	
- Insulation voltage.....	1500V AC
- Version.....	Ethernet 10/100Base-T/TX
- Green LED	indicates link activity
- Yellow LED	link status: 10Mbit/sec OFF, else ON

Housing

- Type.....plastic cabinet mounting
- Dimensions (W × H × D) 237 × 172 × 45 mm
- Front cutout (W × H)..... 214 × 160 mm
- Material.....PC+ABS
- Wiring.....The terminals are suitable for field or factory wiring, use min. 90°C copper conductors only. The connection of wiring shall be made at the installation site with unprepared conductors by a skilled electrician or under controlled conditions by the manufacturer of the Generator Assemblies and/or Generator Control Panel. The acceptability of the connection of the prepared and unprepared conductors shall be determined in the Generator Assemblies and/or Generator Control Panel. When field wired in the end application, a physical barrier shall be provided between the low voltage wiring connections and higher voltage wiring connections to maintain separation of circuits.
- Recommended tightening torque 5 to 7 pound-force inches / 0.5 to 0.8 Nm
use 60/75 °C copper wire 14 AWG / 2.5 mm² only
use class 1 wire only or equivalent
- Net Weight.....0,85kg
- Silicon panel and pushbuttons for better operation in high-temperature environment
- Waterproof security level IP55 due to rubber seal installed between the controller enclosure and panel fascia
- Metal fixing clips enable perfect in high temperature environment
- Modular design, self-extinguishing ABS plastic enclosure, pluggable connection
- terminals and embedded installation way; compact structure with easy mounting

Display

- 480 × 272 TFT LCD with backlight, multilingual interface (including English, Chinese or other languages) which can be chosen at the site, making commissioning convenient for factory personnel
- LCD wear-resistance and scratch resistance due to hard screen acrylic

Protection

- Protection system.....IP65 from front by using mounting material delivered with device
IP20 from back
- Front folio..... insulating surface
- EMC test (CE)tested according to applicable EMC standards
- ListingsCE marking; UL listing for ordinary locations
- Type approval.....UL recognized component, UL1008, File No.: E527936

Chapter 7. Environmental Data



- Temperature** -----
- Cold, Dry Heat (storage) -25°C (-13°F) / 70°C (158°F)
 - Cold, Dry Heat (operating) -25°C (-13°F) / 70 °C (158°F)
 - Humidity: max. 93%. non-condensing

- Altitude** -----
- Maximum operating altitude 2000 m (6,500 ft)

Chapter 8. Accuracy

Measuring value		Display	Accuracy	Notes
Frequency				
Source 1	$f_{L1N}, f_{L2N}, f_{L3N}$	40.0 to 85.0 Hz	0.1 %	-
Source 2	$f_{L1N}, f_{L2N}, f_{L3N}$	40.0 to 85.0 Hz	0.1 %	-
Voltage				
Source 1	$V_{L1N}, V_{L2N}, V_{L3N},$	0 to 650 kV	1 %	Transformer ratio selectable
Source 2	$V_{L1N}, V_{L2N}, V_{L3N},$	0 to 650 kV	1 %	Transformer ratio selectable
Current				
Load	I_{L1}, I_{L2}, I_{L3}	0 to 32,000 A	1 %	-
Max. value	I_{L1}, I_{L2}, I_{L3}	0 to 32,000 A	1 %	Slave pointer
Real power				
Current total real power value		-2 to 2 GW	2 %	Accuracy depends on the configured transformer ratios
Reactive power				
Current value in L1, L2, L3		-2 to 2 Gvar	2 %	Accuracy depends on the configured transformer ratios
cos ϕ				
Current value cos ϕ_{L1}		lag0.00 to 1.00 to lead0.00	2 %	-
Miscellaneous				
Real energy		0 to 4,200 GWh		not calibrated
Battery voltage		6.5 to 40 V	1 %	-

Reference conditions (to measure the accuracy):

- Input voltage.....sinusoidal rated voltage
- Input currentsinusoidal rated current
- Frequencyrated frequency +/- 2 %
- Power supplyrated voltage +/- 2 %
- Power factor cos ϕ1.00
- Ambient temperature23 °C +/- 2 K
- Warm-up period.....20 minutes

We appreciate your comments about the content of our publications.

Please send comments to: marketing_pg@woodward.com

Please include the manual number from the front cover of this publication.



Woodward GmbH

Handwerkstrasse 29 - 70565 Stuttgart - Germany

Phone +49 (0) 711 789 54-510 • Fax +49 (0) 711 789 54-101

marketing_pg@woodward.com

Homepage

<http://www.woodward.com>

Woodward has company-owned plants, subsidiaries, and branches, as well as authorized distributors and other authorized service and sales facilities throughout the world.

Complete address/phone/fax/e-mail information for all locations is available on our website (www.woodward.com).