







Application Note 51658
(Revision A, 3/2026)
Original Instructions

DLE Fuel Metering Skid
GS40 Valve Swap and Replacement Guide

 General Precautions	<p>Read this entire manual and all other publications pertaining to the work to be performed before installing, operating, or servicing this equipment.</p> <p>Practice all plant and safety instructions and precautions.</p> <p>Failure to follow instructions can cause personal injury and/or property damage.</p>
---	--

 Revisions	<p>This publication may have been revised or updated since this copy was produced. The latest version of most publications is available on the Woodward website.</p> <p style="text-align: center;">Woodward Industrial Support: Get Help</p> <p>If your publication is not there, please contact your customer service representative to get the latest copy.</p>
---	--

 Proper Use	<p>Any unauthorized modifications to or use of this equipment outside its specified mechanical, electrical, or other operating limits may cause personal injury and/or property damage, including damage to the equipment. Any such unauthorized modifications: (i) constitute "misuse" and/or "negligence" within the meaning of the product warranty thereby excluding warranty coverage for any resulting damage, and (ii) invalidate product certifications or listings.</p>
--	--

 Translated Publications	<p>If the cover of this publication states "Translation of the Original Instructions" please note:</p> <p>The original source of this publication may have been updated since this translation was made. The latest version of most publications is available on the Woodward website.</p> <p style="text-align: center;">Woodward Industrial Support: Get Help</p> <p>Always compare with the original for technical specifications and for proper and safe installation and operation procedures.</p> <p>If your publication is not on the Woodward website, please contact your customer service representative to get the latest copy.</p>
---	--

Revisions— A bold, black line alongside the text identifies changes in this publication since the last revision.

Woodward reserves the right to update any portion of this publication at any time. Information provided by Woodward is believed to be correct and reliable. However, no responsibility is assumed by Woodward unless otherwise expressly undertaken.

Contents

WARNINGS AND NOTICES	3
ELECTROSTATIC DISCHARGE AWARENESS	4
CHAPTER 1. GENERAL INFORMATION	5
Introduction.....	5
Tools and Parts	6
CHAPTER 2. GS40 GAS VALVE REMOVAL	7
Example GS40 DLE Skid	7
Conduit Barrier Information	7
GS40 Electrical Removal Instructions.....	8
GS40 Mechanical Removal Instructions	11
CHAPTER 3. GS40 GAS VALVE INSTALLATION	13
GS40 Mechanical Installation Instructions	13
Flex Conduit	13
GS40 Cabling	15
GS40 Conduit Barrier Installation	17
CHAPTER 4. PRODUCT SUPPORT AND SERVICE OPTIONS	20
Product Support Options	20
Product Service Options	20
Returning Equipment for Repair	21
Replacement Parts.....	22
Engineering Services	22
Contacting Woodward's Support Organization	22
Technical Assistance	23
APPENDIX A. CONDUIT STOPPER BOX ASSEMBLY INSTRUCTIONS	24
REVISION HISTORY	26

Illustrations and Tables

Figure 2-1. Example GS40 Skid	7
Figure 2-2. Conduit Barrier Assembly	7
Figure 2-3. GS40 Access Cover	8
Figure 2-4. GS40 Terminal Block Connections.....	8
Figure 2-5. GS40 Grounding Connections.....	9
Figure 2-6. GS40 Conduit Barrier Removal	10
Figure 2-7. GS40 Mechanical Installation	11
Figure 2-8. GS40 Lifting Eye Hole Locations.....	12
Figure 3-1. Liquid Tight Fitting Installation	14
Figure 3-2. Tefzel Grounding Wiring Installation.....	14
Figure 3-3. Tefzel Grounding Lug	15
Figure 3-4. GS40 Cable Prep	15
Figure 3-5. GS40 Analog/Drain Wiring Prep.....	16
Figure 3-6. GS40 Twisted Pair and Final Wiring Prep.....	16
Figure 3-7. Running Cable through Conduit	17
Figure 3-8. Conduit Barrier.....	17
Figure 3-9. Plastic Shipping Plug Locations	19
Table 1-1. GS40 Replacement Tools and Parts List	6

Warnings and Notices

Important Definitions



This is the safety alert symbol used to alert you to potential personal injury hazards. Obey all safety messages that follow this symbol to avoid possible injury or death.

- **DANGER** - Indicates a hazardous situation, which if not avoided, will result in death or serious injury.
- **WARNING** - Indicates a hazardous situation, which if not avoided, could result in death or serious injury.
- **CAUTION** - Indicates a hazardous situation, which if not avoided, could result in minor or moderate injury.
- **NOTICE** - Indicates a hazard that could result in property damage only (including damage to the control).
- **IMPORTANT** - Designates an operating tip or maintenance suggestion.

WARNING

**Overspeed /
Overtemperature /
Overpressure**

The engine, turbine, or other type of prime mover should be equipped with an overspeed shutdown device to protect against runaway or damage to the prime mover with possible personal injury, loss of life, or property damage.

The overspeed shutdown device must be totally independent of the prime mover control system. An over temperature or overpressure shutdown device may also be needed for safety, as appropriate.

WARNING

**Personal Protective
Equipment**

The products described in this publication may present risks that could lead to personal injury, loss of life, or property damage. Always wear the appropriate personal protective equipment (PPE) for the job at hand. Equipment that should be considered includes but is not limited to:

- Eye Protection
- Hearing Protection
- Hard Hat
- Gloves
- Safety Boots
- Respirator

Always read the proper Material Safety Data Sheet (MSDS) for any working fluid(s) and comply with recommended safety equipment.

WARNING

Start-up

Be prepared to make an emergency shutdown when starting the engine, turbine, or other type of prime mover, to protect against runaway or overspeed with possible personal injury, loss of life, or property damage.

Electrostatic Discharge Awareness

NOTICE

Electrostatic Precautions

Electronic controls contain static-sensitive parts. Observe the following precautions to prevent damage to these parts:

- Discharge body static before handling the control (with power to the control turned off, contact a grounded surface and maintain contact while handling the control).
- Avoid all plastic, vinyl, and Styrofoam (except antistatic versions) around printed circuit boards.
- Do not touch the components or conductors on a printed circuit board with your hands or with conductive devices.

To prevent damage to electronic components caused by improper handling, read and observe the precautions in Woodward manual **82715**, *Guide for Handling and Protection of Electronic Controls, Printed Circuit Boards, and Modules*.

Follow these precautions when working with or near the control.

1. Avoid the build-up of static electricity on your body by not wearing clothing made of synthetic materials. Wear cotton or cotton-blend materials as much as possible because these do not store static electric charges as much as synthetics.
2. Do not remove the printed circuit board (PCB) from the control cabinet unless absolutely necessary. If you must remove the PCB from the control cabinet, follow these precautions:
 - Do not touch any part of the PCB except the edges.
 - Do not touch the electrical conductors, the connectors, or the components with conductive devices or with your hands.
 - When replacing a PCB, keep the new PCB in the plastic antistatic protective bag it comes in until you are ready to install it. Immediately after removing the old PCB from the control cabinet, place it in the antistatic protective bag.

IMPORTANT

External wiring connections for reverse-acting controls are identical to those for direct-acting controls.

Chapter 1.

General Information

Introduction

Woodward GS40 Gas Metering Valves installed on Woodward DLE Fuel Skids may be replaced in the field. Special care must be taken to ensure that the valve or skid is not damaged during the valve replacement. This guide serves to help operators through the process of replacing the GS40 Fuel Metering Valve.

IMPORTANT

This guide is not intended to replace any site-specific instructions or safety procedures. Ensure all operations are approved by site safety personnel and leaders prior to performing work.

! WARNING

EXPLOSION HAZARD—Do not remove covers or connect/disconnect electrical connections unless power has been switched off and the area is known to be non-hazardous.

! WARNING

All work should be carried out under safe conditions. Be sure gas is not present, and the environment is safe to work on electrical components. Ensure all power is removed from the fuel skid and surrounding equipment.

Refer to Woodward GS Series Fuel Metering Valve Manual 35136 prior to performing work.

Tools and Parts

Woodward provides multiple replacement kits for the GS40 Fuel Metering Valves on the Woodward DLE Fuel Skids. The following table provides a quick breakdown of the tools required and the hardware provided in each Woodward Replacement Kit to perform a successful GS40 Fuel Metering Valve replacement.

Table 1-1. GS40 Replacement Tools and Parts List

Required Tools:	
Channel Locks	
Wire Cutters	
Needle Nose Pliers	
Phillips and Flat Head Screwdrivers	
Wrenches	1-1/4" Box End Combo Wrench
	Torque Wrench (capable of 122 N·m / 90 lb-ft)
	M8 Hex Wrench
Eye Bolt	M8 x 1.25; appropriately rated for weight of the valve (~150 lbs. [68 kg] for heaviest configuration)
Lifting Straps	
8923-3498 Kit Components:	
Component	Qty
ATEX 1" NPT NP Plug EX 'e'	3 ea.
1.5" SAE Code 61 Flange O-ring, Size 225, Viton	2 ea.
TEW&C 14AWG, 2 Conductor	45 ft.
TEW&C 22AWG, 8 Conductor	15 ft.
Conduit Seal Fitting & Compound	1 ea.
1" to 3/4" Conduit Reducer Fitting	1 ea.
90° 3/4" Liquidtite Conduit Fitting	2 ea.
45° 3/4" Liquidtite Conduit Fitting	2 ea.
3/4" Heavy Duty Flex Conduit	15 ft.
3/4" Conduit Hub, Solid Zinc	1 ea.
3/32" Flex Tubing	4 ft.
1/4" Flex Tubing	4 ft.
1/2" Flex Tubing	4 ft.
Wire Label	40 ea.
Tefzel Cable Ties - 14 inch	5 ea.
Tefzel Cable Ties - 7 inch	15 ea.
Grounding Wire	15 ft.
GS40 Valve Replacement Guide	1 ea.

Chapter 2. GS40 Gas Valve Removal

Example GS40 DLE Skid

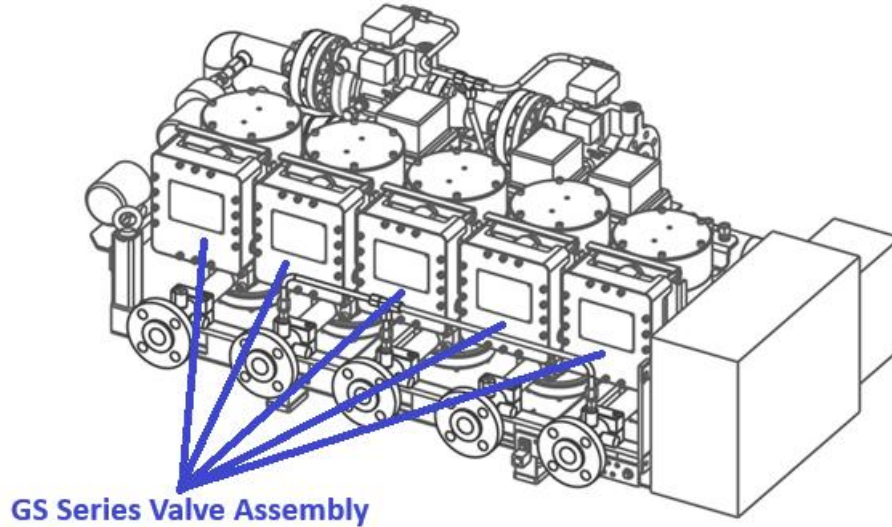

Figure 2-1. Example GS40 Skid

The GS40 Gas Valve location in the skid is shown in Figure 2-1. Actual skid configuration may vary. If multiple valves are going to be replaced, it is recommended to perform this procedure one valve at a time.

Conduit Barrier Information

Some skid models use conduit barriers for the electrical entry into the GS40 Gas Valves. This conduit barrier is required to maintain the hazardous locations certification of the valve and assembly. Special care must be taken when working with the conduit barrier. Damage to the internal wiring may result from improper removal.

NOTICE

Take special care when working with the conduit barrier. Read all instructions prior to uninstalling the barrier for GS40 valve removal.

The following figure shows the parts of the conduit barrier.

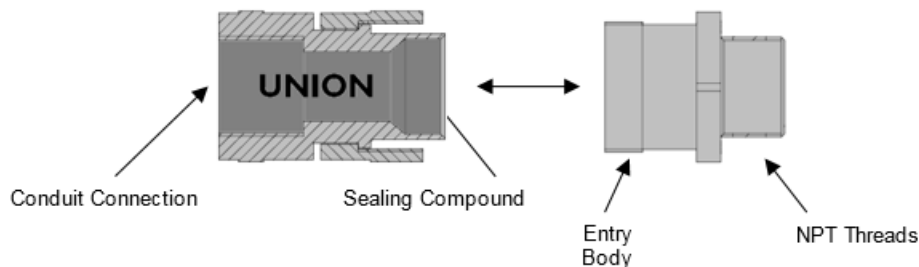

Figure 2-2. Conduit Barrier Assembly

GS40 Electrical Removal Instructions

1. Disconnect power to the DLE Fuel Skid.
2. On the GS40 being replaced, remove the 14 M8x1.25x35mm screws from the valve's driver cover as depicted in the figure below:

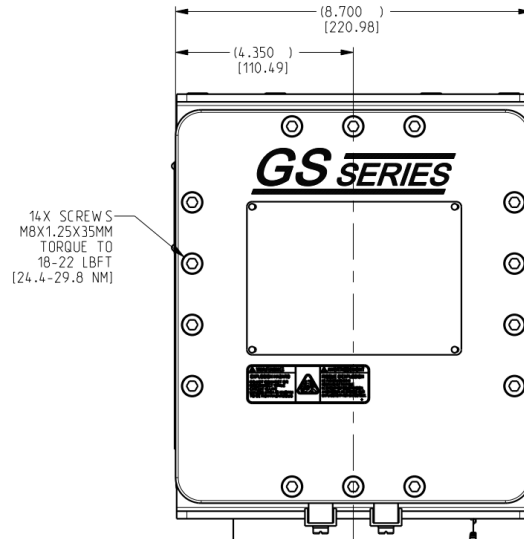

Figure 2-3. GS40 Access Cover

3. Disconnect wiring terminations from the GS40 connection terminal block depicted in red below. **DO NOT** disconnect or damage the wires going into the terminal block depicted in blue:

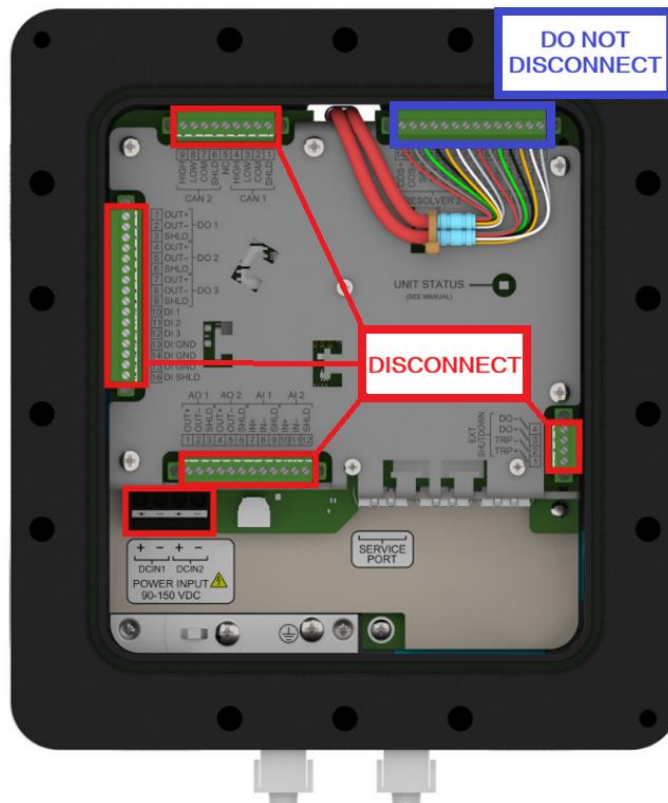

Figure 2-4. GS40 Terminal Block Connections

4. Disconnect wires connected to the grounding lug inside the electronics enclosure as well as the external ground connections depicted below.

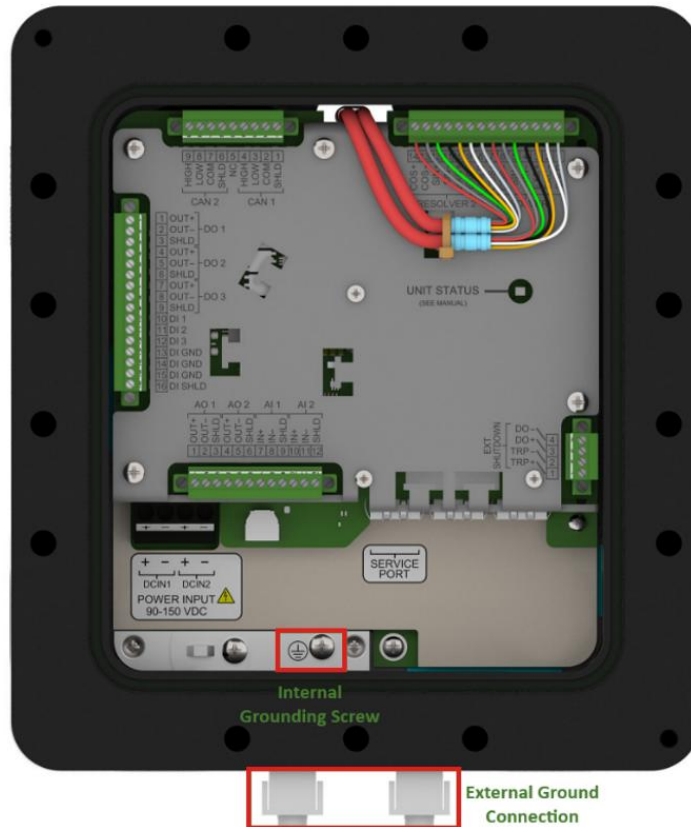

Figure 2-5. GS40 Grounding Connections

5. Remove the conduit barrier union. Take special care to ensure the proper connection is taken apart. See the figure below for information. The barrier uses a fine thread, so it will take some time to unscrew completely.

NOTICE

Use special care not to twist the wires inside the conduit when unscrewing the conduit from the housing. Excessive twisting will cause internal damage to the conductors. It is recommended to extend the conduit when unscrewing it to allow the wires to move more freely within the conduit.

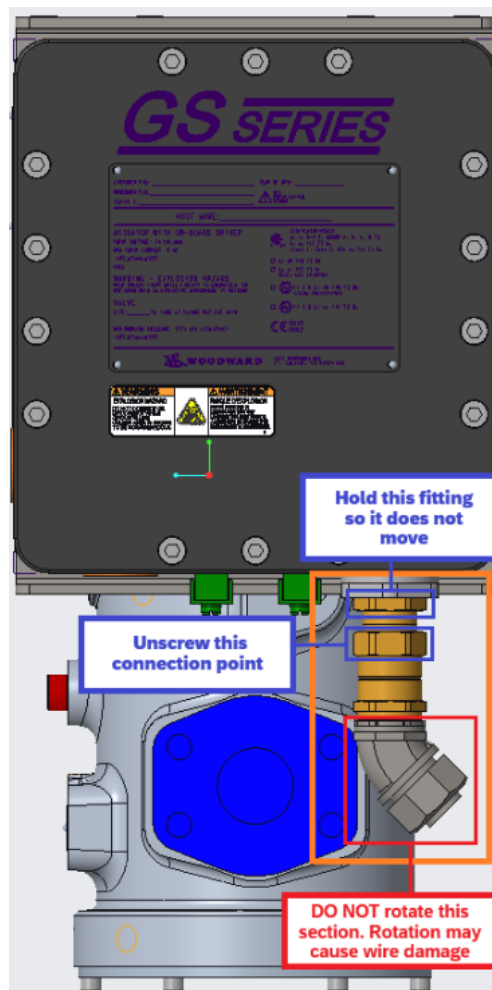

Figure 2-6. GS40 Conduit Barrier Removal

6. Tape wiring and cables inside the GS40 electronics enclosure to prevent damage during removal.
7. Pull the conduit and cabling away from the valve.
8. Replace the GS40 access cover that was previously removed. The access cover should be re-installed and the 14 M8x1.25x35mm screws torqued to 27 N·m (20 lb-ft).
9. Disconnect the terminal block connections inside TB100B. Consult the DLE skid wiring diagram for the correct terminal blocks to disconnect.
10. Remove any tie wraps retaining the GS40 wires inside TB-100B.
11. Remove the conduit fitting nut from the TB100B junction box hub. The GS40 wiring can now be removed from the junction box by pulling on the wire where the conduit nut was removed.

GS40 Mechanical Removal Instructions

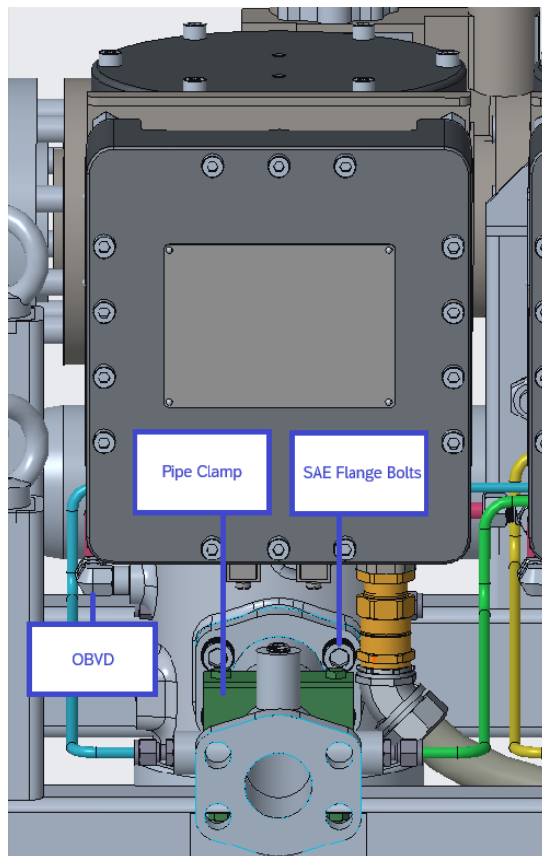

Figure 2-7. GS40 Mechanical Installation

WARNING

The GS40 Gas Valve weighs 50-68 kg (110-150 lbs.) depending on the model. To prevent injury, use a lifting strap and lifting eye that are appropriately rated when handling the GS40 valve. Do not lift or handle the GS40 valve by any conduit or cable. See manual 35136 for proper lifting guidelines and best practices.

1. Disconnect the overboard vent drain tubing (OBVD).
2. Loosen, but do not remove the discharge spool pipe clamps. This will help the valve pull free of the piping.
3. Disconnect the GS40 SAE flange bolts (4 per side).

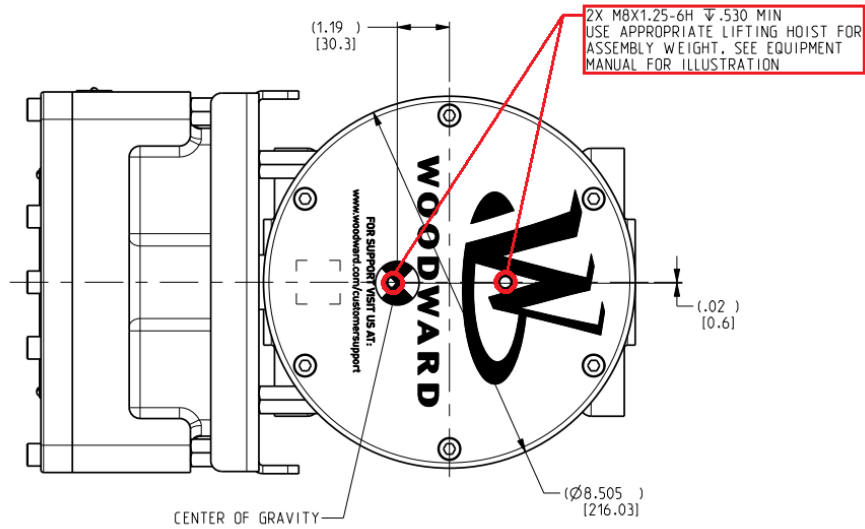

Figure 2-8. GS40 Lifting Eye Hole Locations

4. Remove the GS40 Fuel Metering valve. Utilize the M8x1.25 holes (located on the top of the GS40; see Figure 2-8) and appropriately rated M8 eyebolts to create a secure lifting point for lifting straps.
5. Retain the valve tag and install on the replacement GS40 valve.
6. Carefully package the removed GS40 valve for return to Woodward. Be sure to install shipping covers and plugs on all open ports, entries, and flanges.

NOTICE

Take special care when packaging the GS40 valve for shipment to Woodward. Install shipping covers and plugs on all open ports, entries, and flanges.

Chapter 3.

GS40 Gas Valve Installation

GS40 Mechanical Installation Instructions

1. Inspect the GS40 SAE Flange O-rings for any cracks, pinches, or wear. Replace if necessary.

NOTICE

If O-rings are damaged during valve replacement, Woodward can provide new ones. These are Viton size 225, Woodward part number 1355-423.

WARNING

The GS40 Gas Valve weighs 50-68 kg (110-150 lbs.) depending on the model. To prevent injury, use a lifting strap and lifting eye that are appropriately rated when handling the GS40 valve. Do not lift or handle the GS40 valve by any conduit or cable. See manual 35136 for proper lifting guidelines and best practices.

2. Carefully support and lower the replacement GS40 valve into the open piping on the skid.
3. Install GS40 SAE flange bolts (4 per side), and torque to (28 to 33) N·m / (21 to 24) lb-ft.
4. Re-tighten the discharge pipe clamps. These should be snug around the pipe work.

Flex Conduit

NOTICE

Since it is easier to cut the conduit based on the exact need of the terminations, the flex conduit and cables have been supplied uncut. It may be necessary for field installers to change the lengths of the cable slightly in order to adapt to the current site conditions. The lengths and route of the reinstalled conduit/cable is at the discretion of the field installer in order to complete this task in the best way possible to meet the intention of this reinstallation.

NOTICE

It is strongly recommended that only a competent person, well versed in the installation of electrical systems, shall install any of the required electrical devices or wiring runs. All conduit and wiring shall be installed per the Woodward Control Wiring Diagram.

1. The Woodward GS40 replacement kit provides all components needed to replace the conduit, fittings, and barrier glands. Verify all components listed in Table 1-1 are present and accounted for.
2. Determine the length of flex conduit:
 - a. Measure the required distance of route needed to run flex conduit from the GS40 conduit entry to the gland plate on the TB100 A junction box. When measuring length of flex conduit, be sure that there is enough slack so as not to put tension on the run while ensuring the conduit does not lie on the ground or interfere with other applications. If desired, the new conduit can be cut to the same length as the original conduit.
 - b. Cut the flex conduit supplied with this kit to specific length.
3. Install Liquid Tight conduit fittings (see Figure 3-1).

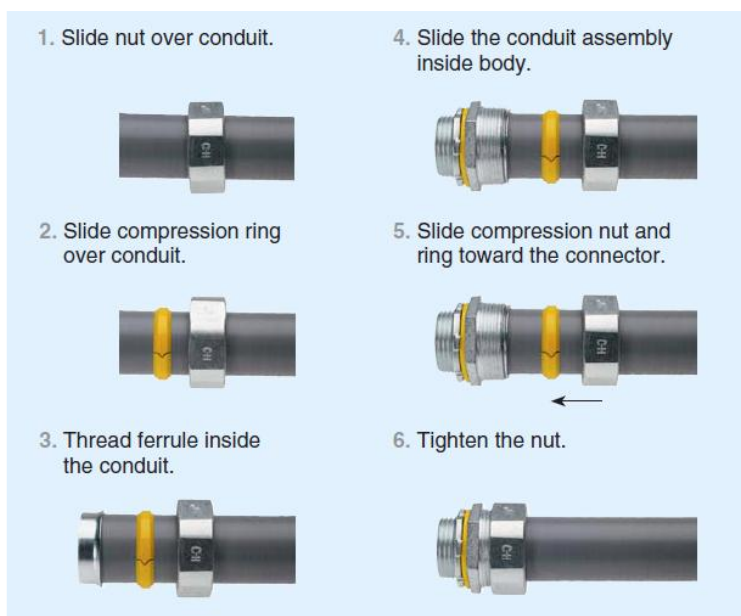

Figure 3-1. Liquid Tight Fitting Installation

4. After installing the fittings, remove the stainless-steel conduit tags from the previously installed conduit runs and install them on the new conduit.
5. Install green/yellow ground wire:
 - a. Measure and cut the provided green/yellow Tefzel grounding wire to equal lengths as the new flex conduit.
 - b. Run the wire along the flex conduit and fasten with supplied Tefzel cable ties (see figures below).



Figure 3-2. Tefzel Grounding Wiring Installation



Figure 3-3. Tefzel Grounding Lug

GS40 Cabling

1. Measure the required length of cable using the flex conduit previously cut. A 45 cm (18 inch) lead of cable is needed on the GS40 valve side, and a 90 cm (3 foot) lead is needed on the junction box side.
2. Cut the cable to the preferred length.
3. Strip the metal sheath off the cables.
4. Strip back the black sheath 45 cm (18 inches) on the valve side and 90 cm (3 feet) on the junction box side. Carefully remove all foil and plastic wrap from all internal wires (refer to Figure 3-4 below).

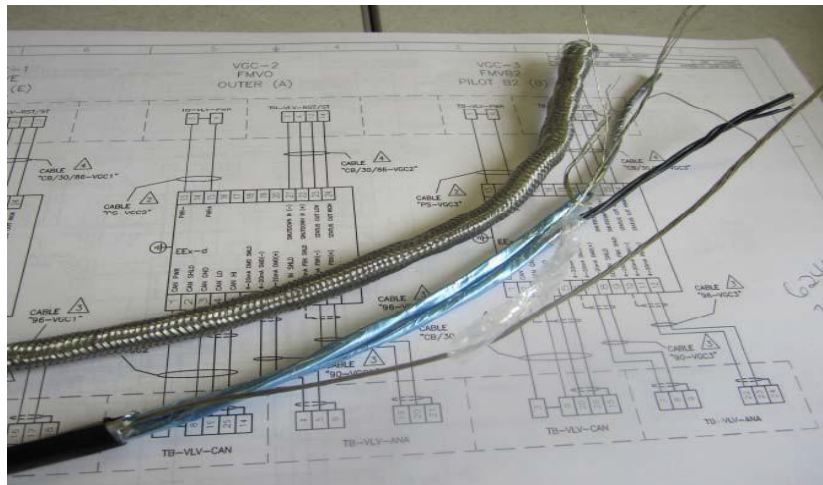

Figure 3-4. GS40 Cable Prep

5. All unprotected analog/drain wires must be protected with 3/32" flex tubing shrink wrap (provided in kit). The 3/32" flex tubing should be installed the entire length of the exposed wire.
6. Each pair with its shield should be isolated using the 1/4" flexible shrink wrap tubing (provided in kit). This should be installed from the end of the black sheath to between 40 to 50 mm (1.5 to 2 inches) up the exposed cable.
7. Once all analog wires have been protected and the pairs have been separated, 1/2" flex tubing shrink wrap (provided in kit) should be used to cover 25 mm (1 inch) below the exposed wire to 75

mm (3 inches) above the exposed wire. The 3/32" flex tubing of the pairs should be completely covered, or barely exposed (see figures below).



Figure 3-5. GS40 Analog/Drain Wiring Prep



Figure 3-6. GS40 Twisted Pair and Final Wiring Prep

8. Using electrical tape, secure the end of each side of the cable.
9. Thread the cable through the conduit. Ensure that the specified length of 45 cm (18 inches) is on the valve side with the 90-degree fitting, and the 90 cm (3 feet) are on the junction box side with the 45-degree fitting.



Figure 3-7. Running Cable through Conduit

GS40 Conduit Barrier Installation

NOTICE

Please refer to the manufacturer's installation instructions in the appendix. After the sealing compound has cured, do not remove the conduit barriers or attempt to decouple the conduit barrier union.

NOTICE

Take special precautions to not allow debris to enter the valve driver conduit port.

1. Install the 1" to 3/4" reducer conduit fitting on the 1" NPT front right GS40 driver conduit entry.
2. With the conduit barrier, separate the union and entry body halves.
3. Pre-install the 3/4-inch bushing and 3/4-inch conduit to the 3/4-inch NPT female side of the union.

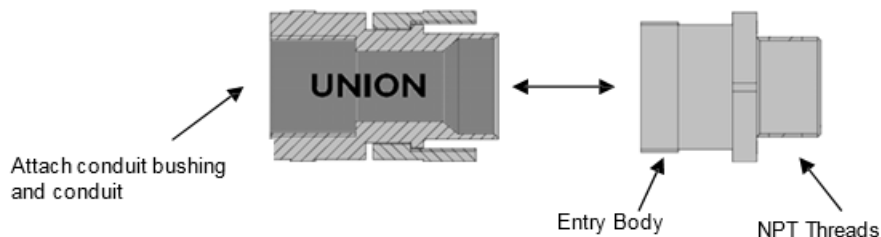

Figure 3-8. Conduit Barrier

4. Insert provided cotton filling into the union ferrule, making sure to evenly distribute the filling along the cable cores and evenly packing within the conduit union ferrule to create a seal that will prevent T2000 resin-based compound from seeping past once applied.
5. Install the entry body into the union with seven full turns.
6. After checking T2000 compound is not passed its "Use By" date, remove cap and assemble applicator nozzle.
7. Prime nozzle by pushing plunger and dispensing a small amount of compound.



CAUTION

Be sure to wear gloves when handling the compound.

NOTICE

Failure to prime nozzle can lead to adverse effects in how the compound cures

8. Holding the conduit gland assembly concentrically, splay the cable cores.
9. Apply the T2000 compound:
 - a. Starting at the middle, inject the compound between the cores approximately halfway up the internal bore.
 - b. Re-straighten the cable cores and bundle wires together with electrical tape about 30 cm (12 inches) from the entry body to keep them close together for easier workability.
 - c. Resume applying the compound around the outer cores until level is just below the entry body face.
10. Clean excess compound from entry body face and threads if overfill occurred prior to compound curing in 60 minutes at 23 °C (68 °F). Compound is considered cured when it is no longer tacky and hard to touch.
11. Install the male NPT threaded entry body into the reducing conduit fitting.
 - a. Route the GS40 wires through the entry body.
 - b. Thread the entry body into the housing conduit port until hand tight.
 - c. Tighten with a wrench until firmly snug approximately ½ turn. Do not over-tighten.

WARNING

Do not attempt to decouple the union. Damage to the compound or wires can result in a compromise of the protective flame path that the compound provides.

NOTICE

Do not attempt to rotate the sealing device. Damage to the wires can result in loss of component functionality.

12. Reconnect all wiring inside the GS40 driver, including the yellow/green safety wire connection to the GS40 internal ground. Take particular care to double check that all wire labels are routed to the appropriate terminal blocks.

NOTICE

Refer to GS Series Gas Valve manual 35136 for information about wire pinout and configuring the valve for use with the VPC Service Tool.

13. Reconnect the elbows and conduit to each other.
14. Land the new wires to the appropriate terminal blocks within the TB100B junction box and fasten the yellow/green ground leads to the skid grounding pad.

NOTICE

All wiring shall be installed per the applicable Woodward Electrical Drawing for the Woodward DLE Fuel Skid model number. Failure to do so can impede the fuel valve's function and/or cause permanent damage.

15. Once the valve has been powered and properly configured, the access cover should be reinstalled and all 14 M8x1.25x35mm screws shall be torqued to 27 N·m (20 lb-ft).
16. Replace the plastic shipping caps in the unused conduit entries (if applicable) with the provided ATEX 1" NPT NP Plugs.

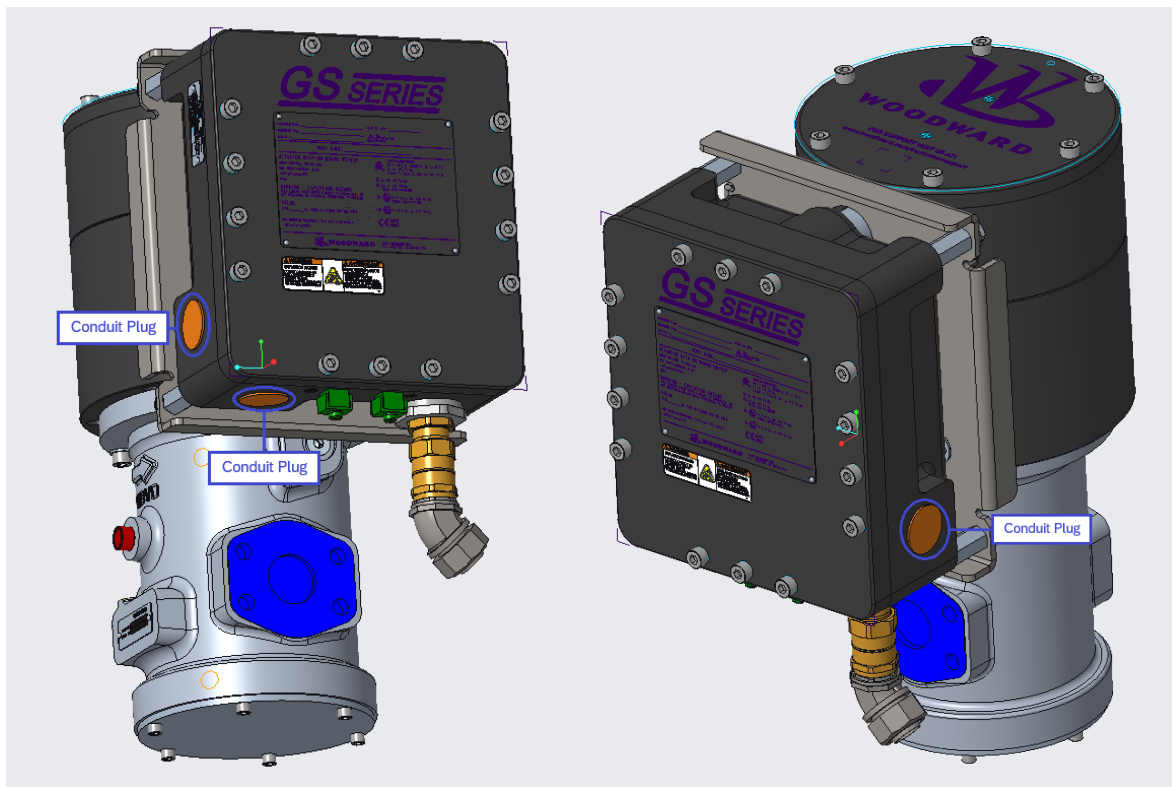

Figure 3-9. Plastic Shipping Plug Locations

Chapter 4.

Product Support and Service Options

Product Support Options

If you are experiencing problems with the installation, or unsatisfactory performance of a Woodward product, the following options are available:

- Consult the troubleshooting guide in the manual.
- Contact the manufacturer or packager of your system.
- Contact the Woodward Full Service Distributor serving your area.
- Contact Woodward technical assistance (see “How to Contact Woodward” later in this chapter) and discuss your problem. In many cases, your problem can be resolved over the phone. If not, you can select which course of action to pursue based on the available services listed in this chapter.

OEM or Packager Support: Many Woodward controls and control devices are installed into the equipment system and programmed by an Original Equipment Manufacturer (OEM) or Equipment Packager at their factory. In some cases, the programming is password-protected by the OEM or packager, and they are the best source for product service and support. Warranty service for Woodward products shipped with an equipment system should also be handled through the OEM or Packager. Please review your equipment system documentation for details.

Woodward Business Partner Support: Woodward works with and supports a global network of independent business partners whose mission is to serve the users of Woodward controls, as described here:

- A **Full Service Distributor** has the primary responsibility for sales, service, system integration solutions, technical desk support, and aftermarket marketing of standard Woodward products within a specific geographic area and market segment.
- An **Authorized Independent Service Facility (AISF)** provides authorized service that includes repairs, repair parts, and warranty service on Woodward's behalf. Service (not new unit sales) is an AISF's primary mission.

A current list of Woodward Business Partners is available at:

<https://www.woodward.com/en/support/industrial/service-and-spare-parts/find-a-local-partner>

Product Service Options

The following factory options for servicing Woodward products are available through your local Full-Service Distributor or the OEM or Packager of the equipment system, based on the standard Woodward Product and Service Warranty (Woodward North American Terms and Conditions of Sale 5-09-0690) that is in effect at the time the product is originally shipped from Woodward or a service is performed:

- Replacement/Exchange (24-hour service)
- Flat Rate Repair
- Flat Rate Remanufacture

Replacement/Exchange: Replacement/Exchange is a premium program designed for the user who is in need of immediate service. It allows you to request and receive a like-new replacement unit in minimum time (usually within 24 hours of the request), providing a suitable unit is available at the time of the request, thereby minimizing costly downtime. This is a flat-rate program and includes the full standard Woodward product warranty (Woodward North American Terms and Conditions of Sale 5-09-0690).

This option allows you to call your Full-Service Distributor in the event of an unexpected outage, or in advance of a scheduled outage, to request a replacement control unit. If the unit is available at the time of the call, it can usually be shipped out within 24 hours. You replace your field control unit with the like-new replacement and return the field unit to the Full-Service Distributor.

Charges for the Replacement/Exchange service are based on a flat rate plus shipping expenses. You are invoiced the flat rate replacement/exchange charge plus a core charge at the time the replacement unit is shipped. If the core (field unit) is returned within 60 days, a credit for the core charge will be issued.

Flat Rate Repair: Flat Rate Repair is available for the majority of standard products in the field. This program offers you repair service for your products with the advantage of knowing in advance what the cost will be. All repair work carries the standard Woodward service warranty (Woodward North American Terms and Conditions of Sale 5-09-0690) on replaced parts and labor.

Flat Rate Remanufacture: Flat Rate Remanufacture is very similar to the Flat Rate Repair option with the exception that the unit will be returned to you in "like-new" condition and carry with it the full standard Woodward product warranty (Woodward North American Terms and Conditions of Sale 5-09-0690). This option is applicable to mechanical products only.

Returning Equipment for Repair

If a control (or any part of an electronic control) is to be returned for repair, please contact your Full-Service Distributor in advance to obtain Return Authorization and shipping instructions.

When shipping the item(s), attach a tag with the following information:

- Return authorization number
- Name and location where the control is installed
- Name and phone number of contact person
- Complete Woodward part number(s) and serial number(s)
- Description of the problem
- Instructions describing the desired type of repair

Packing a Control

Use the following materials when returning a complete control:

- Protective caps on any connectors
- Antistatic protective bags on all electronic modules
- Packing materials that will not damage the surface of the unit
- At least 100 mm (4 inches) of tightly packed, industry-approved packing material
- A packing carton with double walls
- A strong tape around the outside of the carton for increased strength

NOTICE

To prevent damage to electronic components caused by improper handling, read and observe the precautions in Woodward manual 82715, *Guide for Handling and Protection of Electronic Controls, Printed Circuit Boards, and Modules*.

Replacement Parts

When ordering replacement parts for controls, include the following information:

- The part number(s) (XXXX-XXXX) that is on the enclosure nameplate
- The unit serial number, which is also on the nameplate

Engineering Services

Woodward offers various Engineering Services for our products. For these services, you can contact us by telephone, by email, or through the Woodward website.

- Technical Support
- Product Training
- Field Service

Technical Support is available from your equipment system supplier, your local Full-Service Distributor, or from many of Woodward's worldwide locations, depending upon the product and application. This service can assist you with technical questions or problem solving during the normal business hours of the Woodward location you contact. Emergency assistance is also available during non-business hours by phoning Woodward and stating the urgency of your problem.

Product Training is available as standard classes at many of our worldwide locations. We also offer customized classes, which can be tailored to your needs and can be held at one of our locations or at your site. This training, conducted by experienced personnel, will assure that you will be able to maintain system reliability and availability.

Field Service engineering on-site support is available, depending on the product and location, from many of our worldwide locations or from one of our Full-Service Distributors. The field engineers are experienced both on Woodward products as well as on much of the non-Woodward equipment with which our products interface.

For information on these services, please contact one of the Full-Service Distributors listed at:

<https://www.woodward.com/en/support/industrial/service-and-spare-parts/find-a-local-partner>

Contacting Woodward's Support Organization

For the name of your nearest Woodward Full-Service Distributor or service facility, please consult our worldwide directory at <https://www.woodward.com/support>, which also contains the most current product support and contact information.

You can also contact the Woodward Customer Service Department at one of the following Woodward facilities to obtain the address and phone number of the nearest facility at which you can receive information and service.

Products Used in Electrical Power Systems	
<u>Facility</u>	<u>Phone Number</u>
Brazil	+55 (19) 3708 4800
China	+86 (512) 8818 5515
Germany	+49 (711) 78954-510
India	+91 (124) 4399500
Japan	+81 (43) 213-2191
Korea	+82 (51) 636-7080
Poland	+48 (12) 295 13 00
United States	+1 (970) 482-5811

Products Used in Engine Systems	
<u>Facility</u>	<u>Phone Number</u>
Brazil	+55 (19) 3708 4800
China	+86 (512) 8818 5515
Germany	+49 (711) 78954-510
India	+91 (124) 4399500
Japan	+81 (43) 213-2191
Korea	+82 (51) 636-7080
United States	+1 (970) 482-5811

Products Used in Industrial Turbomachinery Systems	
<u>Facility</u>	<u>Phone Number</u>
Brazil	+55 (19) 3708 4800
China	+86 (512) 8818 5515
India	+91 (124) 4399500
Japan	+81 (43) 213-2191
Korea	+ 82 (51) 636-7080
Poland	+48 (12) 295 13 00
United States	+1 (970) 482-5811

Technical Assistance

If you need to contact technical assistance, you will need to provide the following information. Please write it down here before contacting the Engine OEM, the Packager, a Woodward Business Partner, or the Woodward factory:

General

Your Name _____

Site Location _____

Phone Number _____

Fax Number _____

Prime Mover Information

Manufacturer _____

Turbine Model Number _____

Type of Fuel (gas, steam, etc.) _____

Power Output Rating _____

Application (power generation, marine,
etc.) _____

Control/Governor Information

Control/Governor #1

Woodward Part Number & Rev. Letter _____

Control Description or Governor Type _____

Serial Number _____

Control/Governor #2

Woodward Part Number & Rev. Letter _____

Control Description or Governor Type _____

Serial Number _____

Control/Governor #3

Woodward Part Number & Rev. Letter _____

Control Description or Governor Type _____

Serial Number _____

Symptoms

Description _____

If you have an electronic or programmable control, please have the adjustment setting positions or the menu settings written down and with you at the time of the call.

Appendix A.

Conduit Stopper Box Assembly Instructions

Peppers Cable Glands Ltd. Stanhope Road Camberley GU15 3BT UK.

EC2-S*F / EC2-S*M Eclipse Compound-Filled Conduit Stopper Box – ASSEMBLY INSTRUCTIONS

Brief Description

The Peppers EC2-S*F and EC2-S*M compound filled type Conduit Stopper Box is for outdoor use in the appropriate Hazardous Areas with conductors carried in conduit, providing a flameproof barrier entry into enclosures and as a line bushing for terminating flying leads or for the direct inter-connection of associated enclosures. It gives environmental protection to IP66, IP68 (100 metres for 7 days), IP69 and Deluge.

Warning

Please read these instructions carefully. These products should not be used in applications except as detailed here or in our datasheets, unless confirmed in writing by Peppers. Peppers take no responsibility for any damage, injury or other consequential loss caused where products are not installed or used according to these instructions. This leaflet is not intended to advise on the selection of product. Further guidance can be found in the standards listed overleaf or the prevailing code of practice. The compound used within this cable gland has application limitations and may be adversely affected by some solvent vapours. If such vapours are likely to be present when the cable gland is in service, necessary precautions should be taken. Peppers Technical Datasheet can be downloaded from our website for further guidance. Prior to use the compound should be stored in a dry area at temperatures between 5°C and 30°C.

STEP-BY-STEP FITTING INSTRUCTIONS

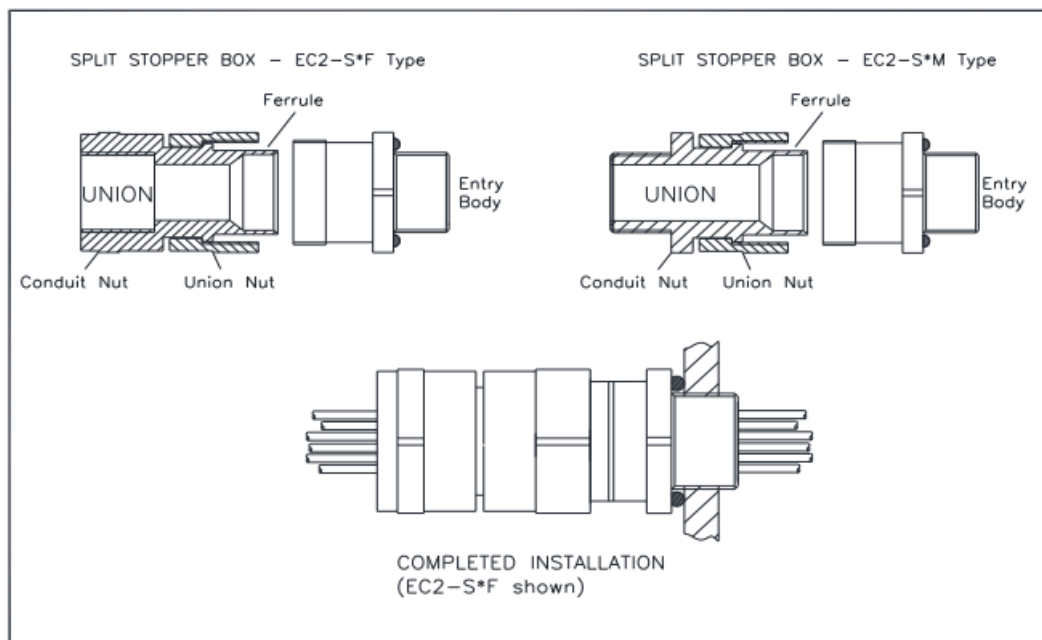

STEP-BY-STEP FITTING INSTRUCTIONS

- 1 Split Stopper Box as shown. Put cotton filling to one side. **Warning.** The entry body of this cable gland is coated with a releasing agent to ensure the compound form can be inspected after curing. The entry body should not be treated with any lubricant or be exposed to any solvents. The internal bore of the entry body must not be damaged. Any handling during the course of normal installation will not affect the operation of the releasing agent.
- 2 Slide Union Assembly onto cable as shown.
- 3 For EC2-S*F glands apply suitable seal / sealant to conduit threads to maintain ingress protection. Screw Union onto conduit. For both EC2-S*F and EC2-S*M glands - prepare the conductors to suit the installation and pass through the union assembly.
- 4 Pack cotton filling around the cable and push inside front of Ferrule ensuring taper section is clear. Note, the cotton filling should fill any gaps between the cable sheath and the metal component to prevent the compound from travelling past the cable when injected. This will ensure a full fill and correct form, see Figure 2.
- 5 Engage Union assembly into Entry Body. Rotate Rear Assembly 7 full turns.

HEALTH AND SAFETY WARNING The compound can cause eye and skin irritation. For your personal protection, wear the gloves supplied whilst in contact with the compound. **A COMPREHENSIVE SAFETY DATA SHEET IS AVAILABLE FOR DOWNLOAD FROM OUR WEBSITE.**

- 6 Check compound has not passed its "Use By" date. Remove cap from cartridge and assemble nozzle.
- 7 Push plunger and dispense a small amount of compound to fill the nozzle. This clears the nozzle of air. **Failure to do so can affect cure.**
- 8 Support the cable and rear gland assembly. Hold the cable roughly concentric. Splay out the cores. Starting at the middle, inject the compound between the cores approximately halfway up internal bore. Re-straighten the cores and bundle with cord or tape (see Figure 1) so they are not disturbed. Continue to inject the compound around the outer cores to just below the Entry Body face. Where cable has large quantity of cores ensure they are bundled near to the gland entry thread to allow withdrawal after cure.
- 9 Clean off any excess compound from Entry Body thread if overfill has occurred before compound cures. Compound will cure from 60 minutes @ 23°C (68°F).
- 10 Before releasing for inspection test the edge of the compound to confirm no longer tacky. Compound must be hard and non-tacky before release is for inspection is performed.
- 11 To release and pull back the joint for inspection, unscrew Union Nut and pull away from the entry body. This will release the compound from the entry body. Do not over rotate as this may damage cable conductors. Pull the Ferrule and compound out for inspection. The compound should appear as in Figure 2 with no gaps, holes or cracks.
- 12 To re-make the joint on an EC2-S*F gland installation hold Conduit Nut and hand-tighten Union Nut. Then refer to table below and tighten using wrench to the given amount. To re-make the joint on an EC2-S*M gland installation screw the Union Nut into 2nd enclosure/equipment. Hand-tighten, then suitably secure with a wrench. Hold Conduit Nut and hand-tighten Union Nut. Then refer to Table 2 below and tighten using wrench to the given amount.
- 13 Fit Entry Body. For Entry Body installation torque for O-rings please refer to Table 2. Tapered threads shall be made up wrench tight. Further guidance can be found in Peppers document CT0030 which can be found on our website. The equipment can now be energised.

Issue: 4
Date: 15/07/2022

www.peppers.co.uk

Doc: PA129
Page 1 of 2

Peppers Cable Glands Ltd. Stanhope Road Camberley GU15 3BT UK.

EC2-S*F / EC2-S*M Eclipse Compound-Filled Conduit Stopper Box – ASSEMBLY INSTRUCTIONS

Figure 1



Figure 2



Table 2. Tightening information (Instruction 12), and permitted cores

Stopper Box Size	Entry Body Tightening Torque Point 13	Tighten Union Nut using wrench up to	Inner Sheath Min	Maximum Cable Size	Max Diameter Over Cores	Max No. of Cores
16S	5Nm	½-turn	4.0	10.0	8.9	12
20	5Nm	½-turn	4.0	14.0	12.5	20
25	5Nm	½-turn	8.0	18.5	16.5	30
32	5Nm	½-turn	14.0	26.3	23.5	50
40	5Nm	½-turn	16.0	32.2	28.8	65
50S	10Nm	½-turn	20.0	38.2	34.2	100
50	10Nm	½-turn	20.0	44.1	39.4	100
63S	10Nm	½-turn	30.0	50.1	44.8	130
63	10Nm	½-turn	30.0	56.0	50.0	130

Approvals and Certification

Approval	Certificate Number	Protection Concept / Type
ATEX	CML 19ATEX1113X / CML 21UKEX1036X	Ex db IIC Gb / Ex eb I Mb / Ex eb IIC Gb / Ex ta IIIC Da
UKCA (SI 2016 No. 1107)	CML 19ATEX4114X / CML 21UKEX4037X	II 3G Ex nR IIC Gc
IECEx	IECEx CML 19.0035X	Ex db I Mb / Ex db IIC Gb / Ex eb I Mb / Ex eb IIC Gb / Ex ta IIIC Da / Ex nR IIC Gc
CCC	2022312313000470	Ex d I Mb / Ex d IIC Gb / Ex e I Mb / Ex e IIC Gb / Ex nR IIC Gc / Ex ID A20 IP66
CCoE / PESO	P494321/17 & P494321/20	Ex db I Mb / Ex db IIC Gb / Ex eb I Mb / Ex eb IIC Gb / Ex nR IIC Gc
Lloyd's Register	LR2124442TA	Ex db I Mb / Ex db IIC Gb / Ex eb I Mb / Ex eb IIC Gb / Ex ta IIIC Da / Ex nR IIC Gc

Installation Guidance

Point	Advice
1	EN/IEC 60079-10 EN/IEC 60079-14
2	Installation should only be carried out by a competent electrician, skilled in cable gland installation.
3	Comprehensive details of the compliance standards can be found on the product certificates which are available for download from our website
4	NO INSTALLATION SHOULD BE CARRIED OUT UNDER LIVE CONDITIONS.
5	Threaded entries: the product can be installed directly into threaded entries. Threaded entries should comply with the relevant applicable standards and have a lead-in chamfer to allow for full engagement of the threads. Failure to provide a sufficient lead-in chamfer may lead to ingress sealing issues. For Ex db applications a minimum of 5 fully engaged parallel threads is required. Metric threads are supplied with an o-ring and will maintain IP66 and IP68. Other parallel entry threads will maintain an IP rating of IP64. A Peppers sealing washer should be used to maintain all IP ratings greater than IP64. Whilst Peppers products with tapered threads, when installed into a threaded entry, have been tested to maintain IP66 without any additional sealant, due to the differing gauging tolerances associated with the use of tapered threads it is recommended to use a non-hardening thread sealant if an IP rating higher than IP64 is required.
6	To maintain the Ingress Protection rating of the product, the entry hole must be perpendicular to the surface of the enclosure. The surface should be sufficiently flat and rigid to support the assembly and make the IP joint. The surface must be clean and dry. The product incorporates a thread run out according to general machining techniques and will not have a full form thread for the entire length and as such entry threads should have a suitable lead-in chamfer to ensure a seal is maintained. Further guidance can be found on Peppers website. It is the user's/installer's responsibility to ensure that the interface between the enclosure and cable gland is suitably sealed for the required application. Any thread sealant used shall be suitable for use in hazardous area locations, be suitable for the temperature range at the point of mounting, shall not contain evaporating solvent and cannot cause corrosion at the threaded interface when used for dissimilar materials.
7	Where a bonding connection to earth is required a Peppers earth tag should be used. Peppers earth tags have been independently tested to comply with the Category B values given in IEC 62444. Further guidance can be found on Peppers website. Peppers earth tags should be fitted over the external entry thread from either inside or outside the enclosure. If fitted internally they must be secured with a Peppers locknut and optionally a Peppers serrated washer.
8	Peppers external metric entry threads comply with ISO 985-1 and ISO 985-3 with a 6g tolerance fit. Peppers standard metric thread pitch is 1.5mm for threads up to M75 and 2.0mm for size M80 and above. Alternative thread pitches are available upon request. Peppers external NPT threads are in accordance with ASME B1.20.1 with gauging to clause 8.1. All threads comply with the threaded joint requirements of clause 5.3 from IEC 60079-1. Information on other thread types can be found in the product certificates.
9	Once installed do not dismantle except for routine inspection. An inspection should be conducted as per IEC/EN 60079-17. After inspection the gland should be re-assembled as instructed, ensuring the mid cap and back nut are correctly tightened to ensure the cable is secure.
10	The o-ring that is fitted to the outer diameter of the Ferrule (visible on figure 2) is to prevent compound from travelling inside the gland during the assembly process. It has no other function and does not contribute to the protection concept or ingress protection rating of the cable gland.
11	If required an anti-seize lubricant may be used to aid assembly and routine inspection. The lubricant should comply with the prevailing code of practice and care should be taken to ensure no lubricant comes into contact with the cable gland seals as this may impair performance.
12	For chemical resistance information please refer to Peppers T2000 Compound data sheet. Available on request.

Interpretation of Markings. Markings on the outside of this gland carry the following meanings:

Cable Gland Type & Size EC2-S-a-b-ccc-ddd-eee-nn; where: -

a =	Main component material B = brass S = stainless steel	ddd =	Entry thread type and size
b =	Back End Configuration F = female M = male	eee =	Back End Connection Thread type and size
ccc =	Gland size	nn =	Year of manufacture

Special Conditions for Safe Use

- The cable glands/stopper boxes shall not be used in enclosures where the temperature, at the point of entry/mounting, is outside of the range of -60°C to +120°C for Peppers T2000 Compound.
- The interface seals comply with the requirements of the standards listed in this report when the cable glands are fitted to a representative enclosure having a smooth flat mounting surface. In practice the interface between the male thread of the glands and their associated enclosure cannot be defined, therefore it is the users' responsibility to ensure that the appropriate ingress protection level is maintained at these interfaces.
- The parallel threaded entry component threads will be suitably sealed using a method that is applicable to the associated equipment to which the gland will be attached. This will be in accordance with the relevant installation code of practice and will ensure that any ingress protection and restricted breathing sealing requirements are maintained.
- The threaded entry component threads without interface O-ring seals installed in an explosive dust atmosphere, within threaded entries, shall only be fitted into enclosures that have either:
 - parallel entries that will ensure that a minimum of 5 full threads of contact will be maintained, this is in accordance with clause 5.1.2 of EN 60079-31:2014
 - tapered entries that will ensure that a minimum of 3 ½ full threads of contact will be maintained, this is in accordance with clause 5.1.2 of EN 60079-31:2014
- Cable glands with sizes 16S, 20S and 20 shall not be used for Group I, EPL Mb applications where there is a 'high' risk of mechanical damage.



Revision History

Revision A—

- New release

We appreciate your comments about the content of our publications.

Send comments to: industrial.support@woodward.com

Please reference publication **51658**.



PO Box 1519, Fort Collins CO 80522-1519, USA
1041 Woodward Way, Fort Collins CO 80524, USA
Phone +1 (970) 482-5811

Email and Website—www.woodward.com

Woodward has company-owned plants, subsidiaries, and branches, as well as authorized distributors and other authorized service and sales facilities throughout the world.

Complete address / phone / fax / email information for all locations is available on our website.